



Conference of Fundamental Research and Particle Physics, 18-20 February 2015, Moscow, Russian Federation

Measuring and test workbenches of Experimental complex NEVOD

K.G. Kompaniets*, M.B. Amelchakov, N.V. Ampilogov, D.V. Chernov, S.S. Khokhlov, V.V. Kindin, O.I. Likiy, I.A. Shulzhenko, V.V. Shutenko, I.I. Yashin, E.A. Zadeba

National Research Nuclear University MEPhI (Moscow Engineering Physics Institute), Kashirskoe shosse 31, Moscow, 115409, Russia

Abstract

The measuring and test automated workbenches used to maintain the health of existing and commissioning of new detectors of the unique scientific facility "Experimental complex NEVOD" are described. The structure of workbenches and their main characteristics are presented. Workbenches include standard high-precision instruments manufactured by Tektronix, CAEN, Aktakom, and specially designed components and modules. Procedures of measurements and tests are carried out in automatic mode under control of computer. Management programs of workbenches are written on the basis of original methods, allowing to obtain reliable and complete information on the status and characteristics of the components of physical systems. Calibration of equipment is carried out through registration of various components of cosmic rays.

© 2015 The Authors. Published by Elsevier B.V. This is an open access article under the CC BY-NC-ND license

(<http://creativecommons.org/licenses/by-nc-nd/4.0/>).

Peer-review under responsibility of the National Research Nuclear University MEPhI (Moscow Engineering Physics Institute)

Keywords: Cosmic rays, muons, Cherenkov water detector, streamer tube chamber, data acquisition, trigger, test facility

1. Introduction

Experimental complex NEVOD includes a number of unique physical detectors each of them is a complex multi-channel software and hardware device. The number of recording channels is tens of thousands. To obtain reliable physical information, each channel should be stable and satisfy specified parameters. The task of creating and operating this equipment, in turn, requires the development and creation of a large set of measuring and test workbenches.

* Corresponding author. Tel.: +7-495-788-56-99, ext. 9261; fax: +7-499-324-8780.

E-mail address: KGGompaniyets@mephi.ru

2. NEVOD detection system

The basis of the experimental complex is the Cherenkov water detector (CWD) NEVOD [1] with volume of 2000m^2 , around which later other detectors were deployed. The detection system of the CWD NEVOD is a regular lattice of quasi-spherical modules (QSM), which is formed of strings (clusters), each containing 4 or 3 QSM. At the moment 91 QSM (16 strings of 4 QSM and 9 strings of 3 QSM) are installed. To calibrate the detector photomultipliers, on the top and on the bottom of the pool the planes of the scintillation calibration telescopes [1] are placed, which are able to select single-muon tracks passing through the working volume of the detector. The recording system of the CWD NEVOD has a hierarchical structure with the lower level of trigger on the basis of a string (cluster) of QSM and includes intra-module electronics (IE), electronics clusters (EC), cable communications and sets of receivers (SR).

2.1. Stand for PMT testing - CALIPH

Study of the characteristics and selection of PMT for CWD NEVOD is done on the automated stand CALIPH (CALibration PHotomultipliers) [2], intended for complex testing of photomultiplier tubes with a large area of the photocathode (15 cm diameter) in a wide range of detected light flashes, starting with one-electron signal level. Functional diagram of the stand is presented in Fig. 1. Bing created as the main stand for the calibration of PMT when deploying the CWD, now the CALIPH is used for testing PMT, replacement of defective ones and for investigating the characteristics of other types of photomultipliers. The facility includes light isolated box with seats for 80 PMT. The main element is a movable LED matrix, which can be moved in X-Y coordinate directions by the commands of the control computer to be fixed opposite the tested PMT.

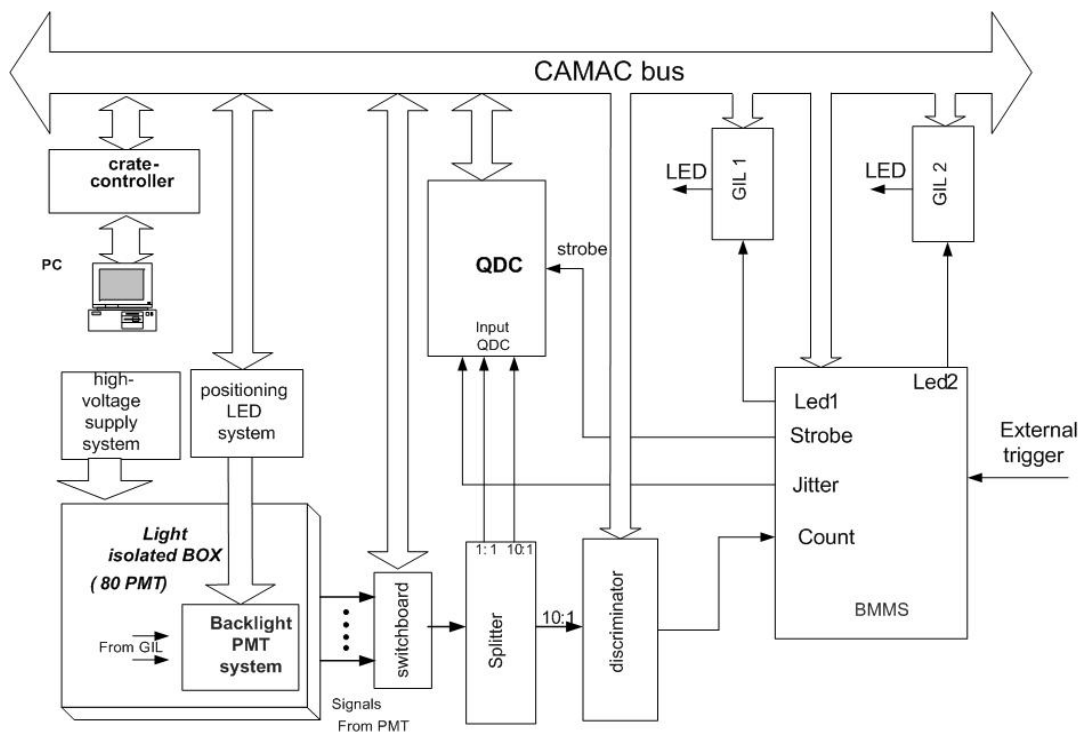

Fig. 1. Scheme of CALIPH-80.

The control system allows operation of a stand according to the preset algorithm of the developed measurement technique. The system has a block organization. All the units are placed in a single crate CAMAC. The exchange of

data between blocks was conducted through the CAMAC bus controller K0607. The main element of the system is the block of measurement mode sets (BMMS) developed for this stand on the basis of programmable logic integrated circuits (FPGA) Altera. With the help of specialized software package MAX+PLUS Baseline, the configuration of the logical part of the control system installation is loaded in it, which includes the organization of trigger execution units, charge to digital converter (QDC), dual LED ignition generator (GIL). Built-in oscillator (50 MHz) allows one to set the duration of control signals and provides the synchronization of blocks. The hardware and software of the workbench allow to explore the following characteristics:

- The counting rate of noise signals at the output of the PMT threshold of 120 mV.
- The amplitude of the response to the standard (malty-electron) illumination [2] from LEDs with the emission wavelength of 470 nm.
- The voltage of the photomultiplier that provides the dynodes system gain 10^6 [3].
- The most probable relative delay of the response of the PMT under standard illumination from the LED.
- The most probable relative delay of the response of the photomultiplier tube in single-electron illumination from the LED corresponding to 10% registration efficiency.
- FWHM (jitter) of the photomultiplier response delay in single-electron illumination from the LED.
- The efficiency of ejection of photoelectrons from the region contiguous to the first dynode under standard illumination from the LED.
- The linearity range of the PMT.

2.2. The bench for testing and calibration of BCE

The block of cluster electronics (string of measuring modules) (BCE) is one of the central elements of a recording system of CWD NEVOD [4]. It combines up to four QSM in a single measuring cluster. BCE handles analog signals from four QSM, provides monitoring of a spectrometric channel and data exchange with higher level systems. The BCE contains: four modules of amplitude analysis of MAA-01P, the processor Board WAFER C400E2VN-RS, interface module MS-01P with temperature sensor, and power module MP-01P. The scheme of testing and calibration BCE is presented in Fig. 2.

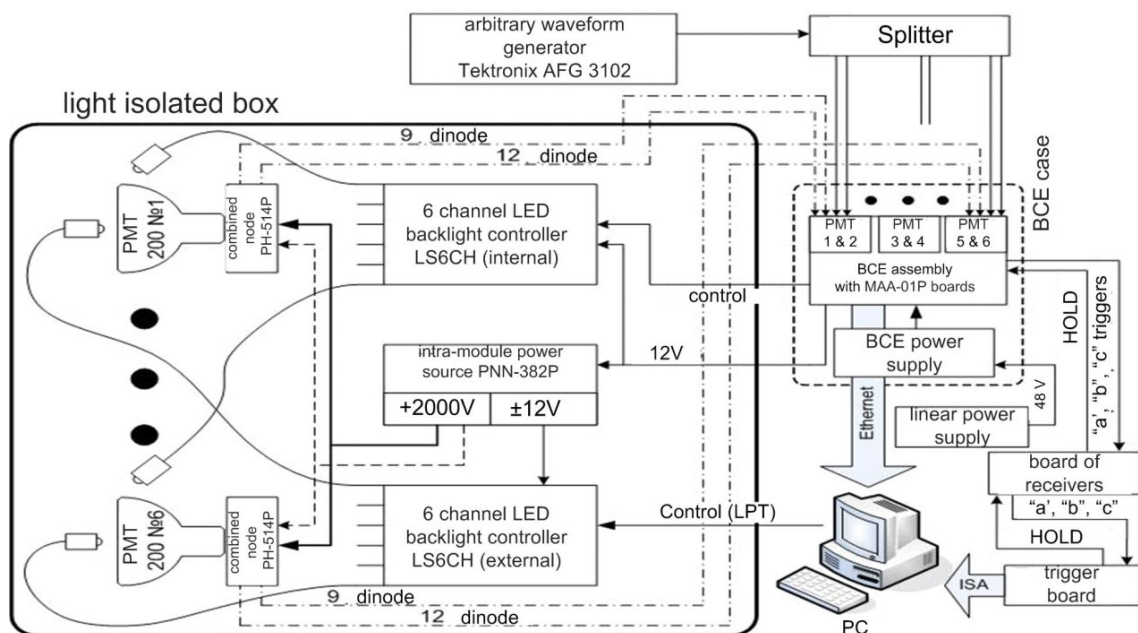

Fig. 2. Diagram of the testing and calibration of BCE system.

The testing and calibration system includes:

- six PMT-200 with known characteristics;
- a set of intra-module QSM electronics, necessary to study the BCE response to the real signals with QSM;
- light isolated box with the system of external illumination;
- BCE case with established signal wire jumper, trigger wire jumper, network cable, cooling fan and power supply;
- linear power supply Mastech HY3005D-3;
- arbitrary waveform generator Tektronix AFG 3102;
- two fan-out of signals from the generator, switching outputs oscillator logic inputs and analog channels boards MAA;
- board of receivers for the collection of trigger signals from the BCE;
- PC for data collection from the BCE and trigger signals from the block of receivers with trigger board, connected via the bus ISA16, to count the trigger signals and the generation of the signal "HOLD";
- software for managing the testing process.

2.3. Stand for certification of LED drivers

Stand for certification of LED drivers is a light isolated box with a photomultiplier FEU-200, PMT electronics board and intra-module LED controller LS6CH. In addition, the stand includes a control computer (PC), dual-channel digital storage oscilloscope LA-n10M7 based on ISA card, external stable unit of low-voltage power supply Mastech HY-3005D-3, and an external high-voltage supply unit BNW-95. The scheme is presented in Fig. 3.

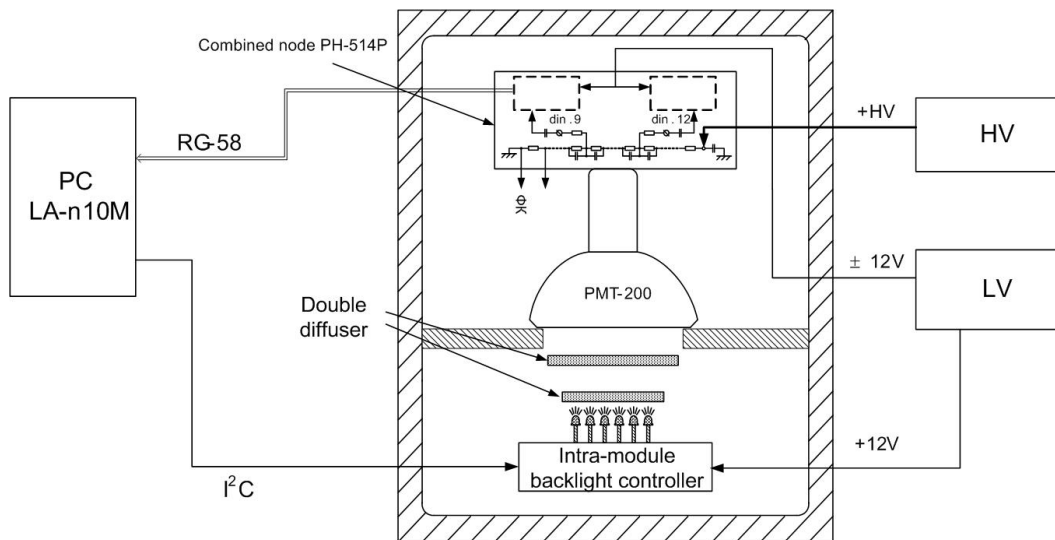

Fig. 3. Scheme of the stand for certification of LED drivers.

Measurement of the PMT signals is performed with a digital oscilloscope LA-n10M7 with ± 2 V range, which is connected to the analog output of 9th dynode channel of PMT electronics board. Control of the LED controller is done via I²C bus, emulated on the LPT port of the host PC. Synchronization of the oscilloscope is made with LPT port on the controller trigger.

2.4. Stand for testing PMT electronics boards

Stand for testing PMT electronics boards is designed for automated testing, certification and selection of intra-module electronics boards (combined node PH-514P) before installing them in quasi-spherical modules and

represents light isolated box with a photomultiplier FEU-200, intra-module power source PNN-382P and dual illumination source based on LED. The composition of the bench: managing PCs, digital storage oscilloscope Aktakom-3116, two-channel LED controller and stable power supply Mastech HY-3005D-3. The stand provides the ability to measure the following characteristics of board PH-514P channels when working directly with FEU-200 in automatic and manual modes:

- the dynamic range of the of the 9th and the 12th dynode analog channels;
- the values of the coefficients of conversion of the charge to the amplitude of the 9th and the 12th dynode analog channels by relative method;
- temporal parameters of the output pulses: slew rate of a signal and its FWHM;
- ratio of analog channels cross-linking;
- pedestal and its dispersion measurements.

2.5. Automated test bench to check the cables

Automated test bench to check the cables allows to set arbitrary combinations of 32 levels at one end of tested cable and determine the status levels at the other end. The chosen methodology of checking cable for breaks, errors in the connections and internal short circuits is to compare the levels displayed on the output register and levels read from the input register.

An example of detecting an internal short circuits in the cable when it is tested is shown in Fig. 4.

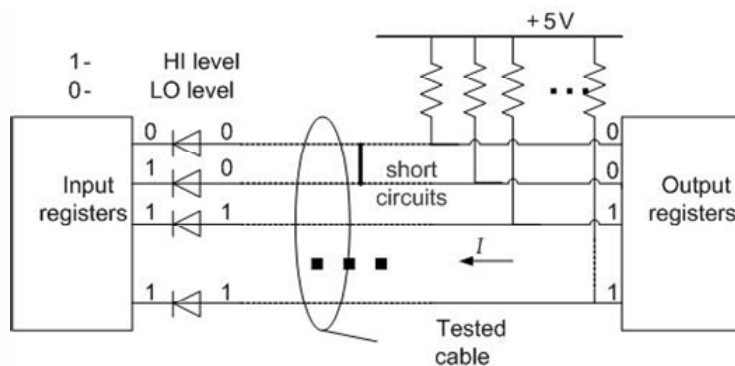

Fig. 4. State levels in registers in the case of a short circuit in the tested cable.

The facility allows to quickly and efficiently test all used in the communications of CWD NEVOD cables and intra-module QSM jumpers for errors in the connections, internal breakages and short circuits.

3. DECOR detection system

Coordinate-tracking detector DECOR [5] is located on the second floor of the NEVOD, around the water pool. The working area of the detector is about 70 m² and consists of 8 eight-layer assemblies (supermodules) with spatial and angular resolution of 1 cm and 1 degree respectively. Each of the 8 planes forming the supermodule consists of 16 chambers. One chamber includes sixteen gas discharge tubes arranged with a pitch of 1 cm and operating in a limited streamer mode [6]. The reception and storage of signals is performed by the reading card STOS M4200 manufactured by the LeCroy company. One reading card includes 16 dual amplifier-discriminators-shapers, four shift register and the PFN of common OR signal.

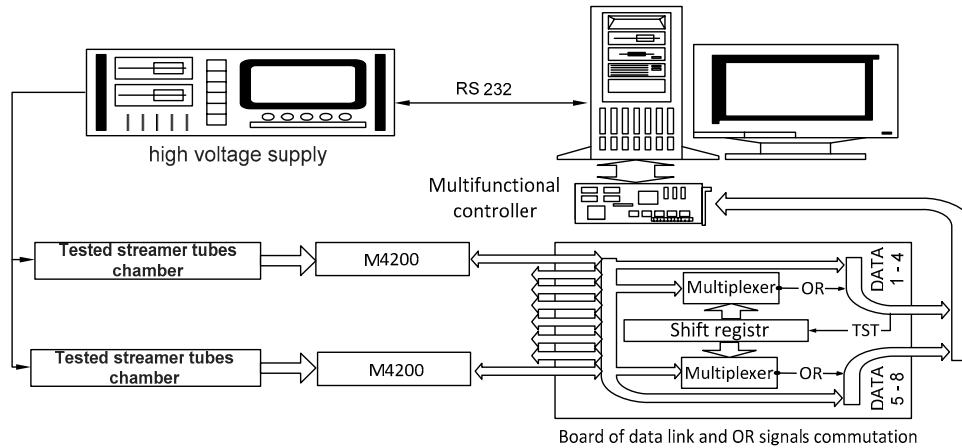

Fig. 5. Block diagram of the stand for testing of the streamer tubes chambers.

3.1. Stand for the selection of streamer tubes chambers

To ensure reliable operation of the detector, the chambers before the assembly had passed a full cycle of preparing, characterizing and selecting, based on the specialized stand that allowed in a short time to inspect more than 1500 streamer tubes chambers (Fig. 5). The test bench provides automated management system of high voltage supply and simultaneous testing of eight streamer chambers. The stand provides the following operations with a streamer tubes chamber:

- high voltage chamber training;
- measuring the effectiveness of the chamber registration;
- measuring the count rate of individual tubes of the chamber;
- recording the received data on magnetic media and their statistical processing.

3.2. Stand for testing of readout boards.

Due to the large number of readout boards needed to organize the data collection system of the DECOR the stand for automated test and data selection of boards was designed and developed.

Structural scheme is presented in Fig. 6 and includes the computer, multifunctional controller, linear demultiplexer and the control unit of the demultiplexer. Linear demultiplexer is used for wiring the signal from the generator on the M4200 board channels. Input signals are a reference amplitude signal and the 32 bit exposure mask. Output signals: up to 32 of triangular shape pulses (pulse width on the basis of 90 ns, the duration of the leading edge 25 ns) in compliance with the established exposure mask.

The stand provides the following operations with the board:

- Testing shift registers and reading performance.
- Bit-assignment group of the tested channels.
- Simultaneous transmission of signals of variable amplitude (from 0 to 120 mV with increments of 0.05 mV) to a group of selected channels.
- Receiving the trigger signal from the board and reading information about detection channels.
- Storing data on magnetic media and their statistical processing.

Method of board test includes a determination of channel-by-channel threshold of 50% efficiency, the calculation of the average and dispersion of the threshold, the test of cross-talk from channel to channel and channel-by-channel check of OR signals.

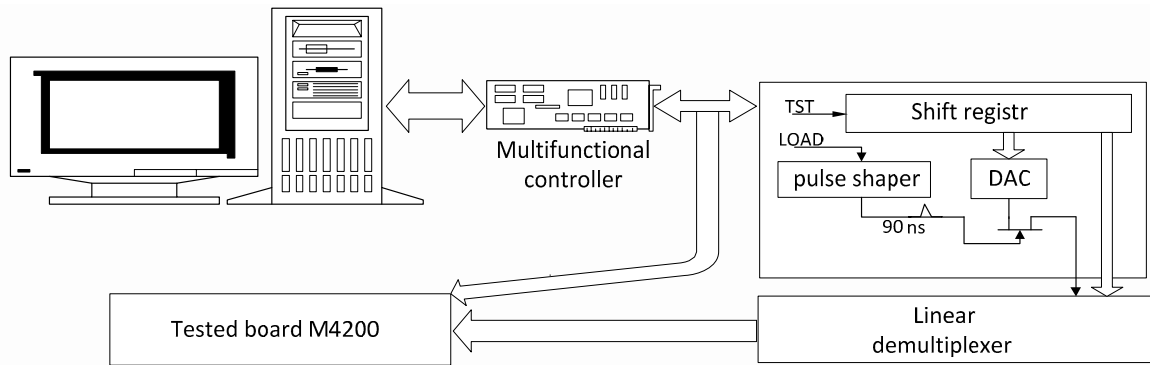

Fig. 6. Block diagram of the stand for testing of the DECOR readout boards.

4. URAGAN detection system

The muon hodoscope URAGAN [7] is a wide-aperture coordinate-tracking detector, which allows to study spatial and angular variations of muon flux from all directions of the upper hemisphere due to different atmospheric and extra-atmospheric processes. The muon hodoscope URAGAN consists of 4 identical assemblies of streamer tube chambers – supermodules (SM) total area of 45 m². Each SM of URAGAN is a stand-alone muon detector with an effective area of registration of 11.5 m², able to record the tracks of muons in real time mode in the range of zenith angles 0° - 80° with high angular (~1°) and spatial (~1 cm) accuracy. The selection of streamer tube chambers and testing readout boards to detector URAGAN was carried out using the previously described test benches for the detector DECOR.

At the same time, high precision reconstruction of the tracks of muons allows us to use the URAGAN supermodule for calibration and precision studies of the sensitivity zones of charged particle detectors [8]. The studied detector is mounted above the top of the coordinate plane (CP) of the URAGAN SM (see Fig. 7).

Supermodule of hodoscope URAGAN registers muon tracks, which cross the part of the upper CP dedicated to trigger events. The size of the working part of the upper CP is chosen larger than the area of the investigated detector. At a signal on the passage of a particle through a region of a trigger event, data on SM detections channels are transmitted to the computer of the URAGAN for an on-line analysis. A trigger for readout and analysis of the detector signals in the study by using an external recording device such as a digital oscilloscope is generated. The transmission of parameters of the track of a muon in each event on the computer that receives the data from the oscilloscope is done by using a connection between computers via Ethernet. This gives the opportunity to study the distribution of amplitudes and charge responses of the test detector, depending on the location of the track; integral and differential efficiency of muon registration, to evaluate the impact of multi-particle events.

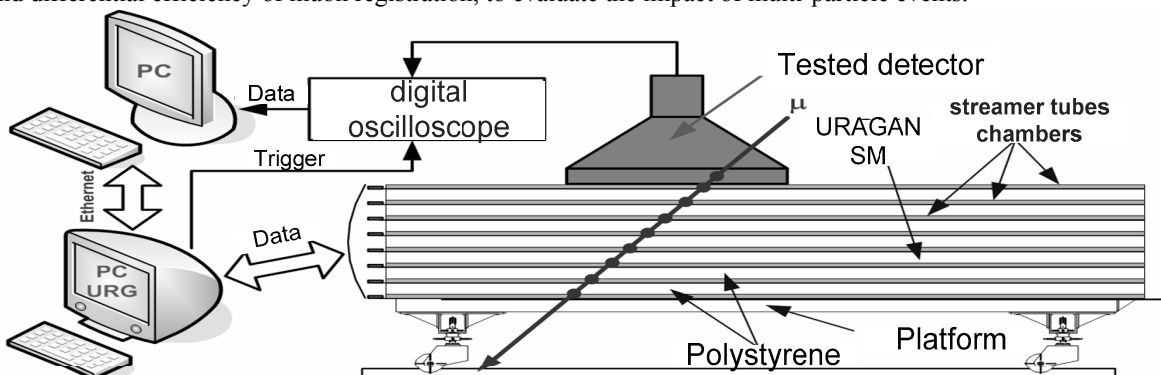

Fig. 7. URAGAN supermodule connected in the mode of testing of charged particle detectors.

Conclusion

All the elements of the Unique Scientific Facility “Experimental complex NEVOD” are tested, calibrated and certified at specialized automated workbenches. The accuracy of the measurements is provided by the muon calibration, testing techniques and use of precision instruments of known manufacturers. Existing software and hardware of “Experimental complex NEVOD” permit the measurements of most of the charged particle detector characteristics in an automated mode.

Acknowledgements

The work was carried out at the Unique Scientific Facility "Experimental complex NEVOD" with the financial support of the State provided by the Ministry of Education and Science (project No. REMEFI59114X0002).

References

- [1] Aynutdinov V.M., Kindin V.V., Kompaniets K.G. et al. Neutrino Water Detector on the Earth's Surface (NEVOD). *Astrophys. Space Sci.* 1997;258:105-116.
- [2] Amelchakov M.B., Bozhenok A.V., Krylova N.A. et al. *Automated test bench for testing the characteristics of large PMT. Preprint 004-04.* Moscow: MEPhI. 2004.
- [3] Aynutdinov V.M., Alalikin V.G., Danilchenko I.A. *Method for measuring the gain dynodes system of photomultiplier tubes. Preprint 082-88.* Moscow: MEPhI. 1988.
- [4] Khokhlov S.S., Amelchakov M.B., Ashikhmin V.V. et al. New measuring system of multipurpose Cherenkov water detector NEVOD. *Astrophys. Space Sci. Trans.* 2011;7:271-273.
- [5] Barbashina N.S., Ezubchenko A.A., Kokoulin R.P. et al. A coordinate detector for studying horizontal fluxes of cosmic rays. *Instrum. Exp. Tech.* 2000;43:743-746.
- [6] Battistoni G., Bellotti E., Bloise C. et al. The NUSEX detector. *Nucl. Instr. and Meth.* 1986;245:277-290.
- [7] Barbashina N.S., Kokoulin R.P., Kompaniets K.G. et al. The URAGAN Wide-Aperture Large-Area Muon Hodoscope. *Instrum. Exp. Tech.* 2008;51:180–186.
- [8] Ampilogov N.V., Barbashina N.S., Kompaniets K.G. et al. Application of the URAGAN Muon Hodoscope to Calibrate Charged Particle Detectors. *Bull. Rus. Acad. Sci. Phys.* 2015;79:386–388.