

Content from this work may be used under the terms of the CC BY 3.0 licence (© 2019). Any distribution of this work must maintain attribution to the author(s), title of the work, publisher, and DOI

# DEVELOPMENT OF INJECTION AND EXTRACTION KICKERS FOR SUPERKEKB DAMPING RING

M. Tawada<sup>†</sup>, M. Kikuchi, Y. Sakamoto, H. Someya, KEK, Ibaraki-ken, Japan  
 K. Tenjin, A. Tokuchi, Pulsed Power Japan Laboratory Ltd., Shiga-ken, Japan

## Abstract

Damping ring (DR) [1] for SuperKEKB has two kicker magnets for the injection and the extraction, respectively. These kickers are required to meet the following specifications: (1) rise and fall time does not exceed 100 ns, (2) two bunches which are 96 ns apart must be kicked by single pulse, (3) the stability of peak current for the extraction kickers must be less than 0.1 %. Kicker magnets are designed as a conventional kicker with a ferrite core. The pulse shape is a double half sine for the two bunch injection. In order to achieve short rise time, a saturable inductance is used. The design and performance of kicker magnets and the power supplies are reported.

## INTRODUCTION

SuperKEKB, is an upgrade project of KEKB, is a double-ring asymmetric collider for the study of the B meson physics. The 7-GeV electron ring (HER) and the 4-GeV positron ring (LER) intersects at an interaction point. DR is required to reduce the injection emittance of the positron beam in order to meet the dynamic aperture restrictions of LER. The DR is located at the end of sector-2 of the Linac. The positron beam is generated at the sector-1 of the Linac and accelerated to 1.1 GeV before the injection to DR. After staying 40 ms in DR, damped beam is extracted from DR and resumed to the entrance of the sector-3 of Linac through a transport line. Basic parameters of DR are shown in Table 1.

The kicker magnets for the injection and extraction to DR have a common design. DR has two bunch-trains that are separated by about 100 ns, each containing two bunches which are 96 ns apart. Because the kicker has to inject or extract one of trains by a single pulse, we have adopted a double half sine pulse shape, whose rise and fall time are less than 100 ns. The design parameters are listed in Table 2.

## DR KICKERS

Kicker magnets are designed as a conventional inductive type with a ferrite core. The kicker coil is symmetrical in shape with respect to horizontal plane and directly connected to the magnetic switch tank which is immersed in the oil in order to reduce the leakage inductance.

Each kicker magnet has its own power supply. The block diagram of the DR kicker power supply is shown in Fig. 2. Two HV chargers and two thyratrons and four magnetic switches are connected in parallel to the kicker magnet to produce double half sine pulse shape. The thyratrons and magnetic switches are placed in separate tanks filled with a

Table 1: Basic Parameters of the Damping Ring

Energy	1.1	GeV
No. of bunch trains	2	
No. of bunches / train	2	
Circumference	135.498	m
Maximum stored current	70.8	mA
Horizontal damping time	11.57	ms
Injected beam emittance	1400	nm
Emittance ratio	5	%
Emittance at extraction (H/V)	42.9 / 3.61	nm
Chamber size (normal cell)	34 <sup>H</sup> × 24 <sup>V</sup>	mm

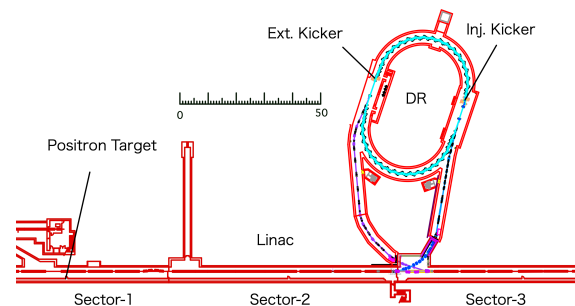

Figure 1: Schematic layout of Linac and DR for SuperKEKB.

silicone oil. Figure 3 shows the picture of DR kicker magnet. The schematic drawing of the thyatron tank and magnetic switch tank are shown in Figure 4.

The pre-trigger pulse starts the inverter to charge the main capacitors in 12 ms, keeping its voltage level in 3 ms before discharging through a thyatron fired by the main trigger. Command charging has been adopted and resulted in better kicker performance with an increase of stability. Its maximum charging voltage is 40 kV. The main trigger makes a half sine pulse of 500 ns as a primary pulse. The primary pulse transmitted by 20D cables of 25 m length, is compressed by the magnetic switch, achieving the required rise time of less than 100 ns. Since the midpoint of the coil is grounded, the applied voltage to the coil amounts to twice the charging voltage. Due to the severe timing jitter requirement of less than 1 ns, dc power supplies for the cathode's as well as the reservoir heater of the thyratrons are used. Charging voltage and its fire timing can be controlled independently for the two pulses. An inherent drawback of a magnetic switch is that a small pre-pulse occurs in order to saturate the inductor. So, we try to reduce the pre-pulse

<sup>†</sup> masafumi.tawada@kek.jp

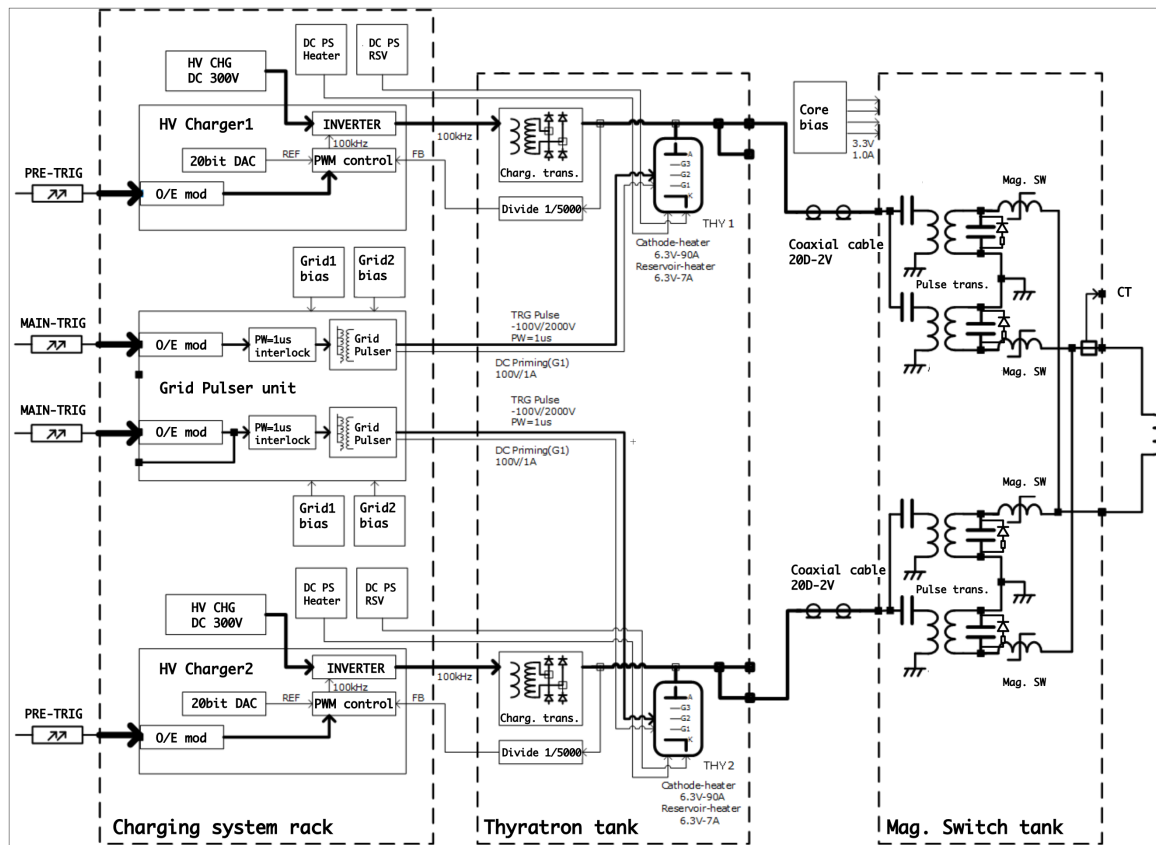

Figure 2: Block diagram of the DR kicker power supply.

Table 2: Design Parameters of the Kicker Magnets for DR

Injection / Extraction	
Deflection angle	5.2 / 4.7 mrad
No. of magnets	2
Peak field	0.04 T
Core length	240 mm
Gap height	53 mm
No. of coil turn	1
Mag. inductance	0.8 $\mu$ H
Peak current	1708 / 1546
Voltage stability	< 0.1 %
Pulse width	300 ns (double half sine)
Rise / Fall time	< 100 ns
Timing jitter	< 1 ns
Max. repetition	50 Hz
pre-pulse & tail noise	< 5 %

as much as possible. Bunch-by-bunch feedback system is indispensable to compensate for the effect of the pre-pulse on the other bunch-train.

Figure 5 shows the double pulse shape of the output current. The voltage stability of 0.059 % ( $6\sigma$ ) and the switching jitter of 0.379 ns ( $3\sigma$ ) have been achieved. Pre-pulse and tail noise are less than 5 %.

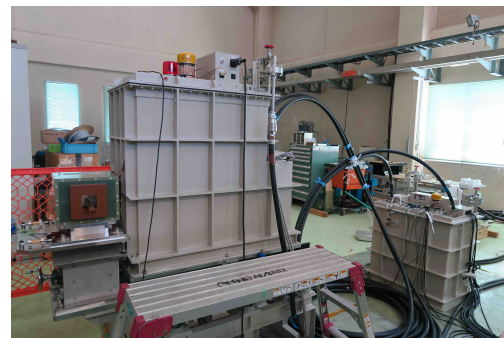

Figure 3: The injection kicker magnet with the magnetic switch tank and the thyratron tank.

### OPTIMIZATION OF TI COATING THICKNESS ON THE CERAMIC DUCT

Because of very short pulse-width, the penetration time and the attenuation of the magnetic fields by the titanium coating can't be neglected. Magnetic fields inside the ceramic duct depends on the pulse shape and the ceramic duct shape as well as its surface resistivity. The transverse dimension is  $52^W \times 47^H$  and the length is 500 mm for the injection kicker and 985 mm for the extraction. The extraction kickers share a common ceramic duct. Because the coil is symmetrical and cannot be halved, in order to assemble the kicker magnet the flange of ceramic duct was designed to

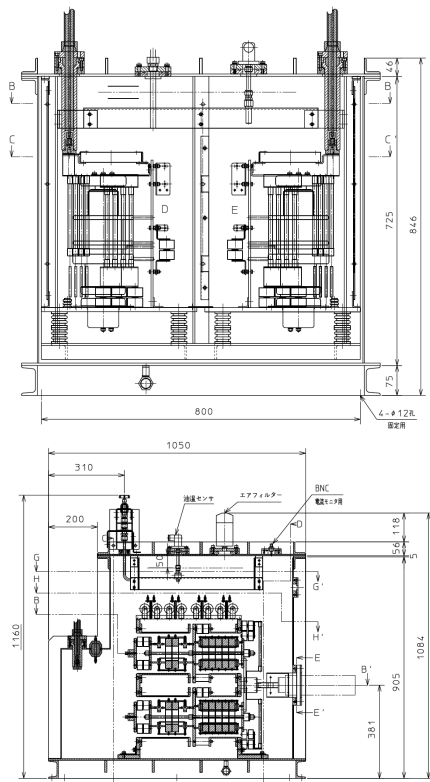

Figure 4: The drawing of the thyatron tank (up) and magnetic switch tank (down). Two thyratrons (e2V cx1836) are housed in a thyatron tank. The magnetic switch consists of four pulse transformers and four saturable inductances.

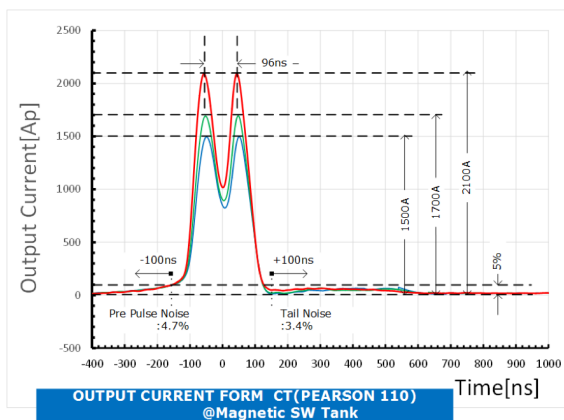

Figure 5: Output current of the kicker magnet without the ceramic duct.

be removable. The ceramic duct is electrically isolated from the power supplies.

The inner surface of the ceramic duct has to be coated with a titanium in order to sufficiently reduce the beam impedance to beam as well as to protect the ceramic duct from the unwanted charge-up. Figure 6 shows simulation results using Opera-2d [2], in comparison with the measurement, for various coating thickness. The measurement was performed using a single pulse for simplicity. The coating thickness

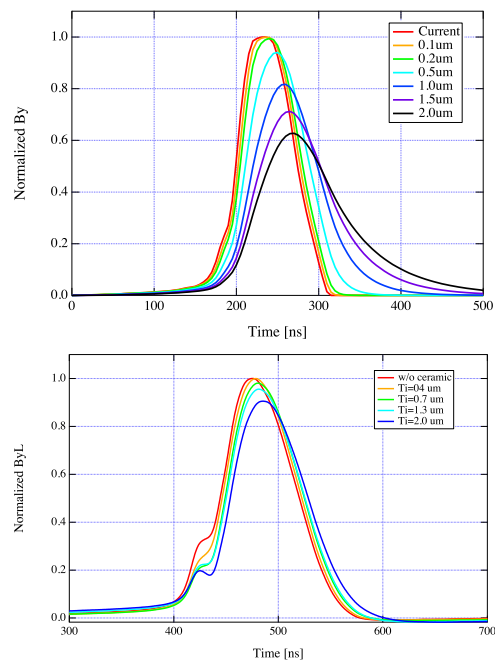

Figure 6: Magnetic fields by simulation (up) and experimental (down) results for a single pulse with various titanium coating thickness. The red line shows the fields from a case without the ceramic duct.

of 0.4  $\mu\text{m}$  was chosen based on this experiments. A delay of about 4 ns are observed for the 0.4  $\mu\text{m}$  coating, which is much smaller than 40 ns by the simulation. It is considered due to the roughness of the about 0.3  $\mu\text{m}$  in the inner surface of the ceramics, which was not made polishing [3].

## CONCLUSION

We have developed kicker magnet for DR injection and extraction, which have two successive semi-sinusoidal pulse shape. The kickers show a good performance in the voltage stability and the timing jitter. DR could store four bunches successfully and has been in operation without any serious problems. However, long-term stability would be a concern because of a finite lifetime of thyratrons. We are developing a semiconductor switch using SI-thyristors in place of thyratrons.

## REFERENCES

- [1] M. Kikuchi, "Reverse-bend FODO lattice applied to damping ring for SuperKEKB", Nucl. Instr. Meth. A 556, pp. 13-19 (2006).
- [2] Opera-2d, Dassault systems, <http://operafea.com>.
- [3] N. Terunuma, H. Nakayama, and J. Urakawa, "Study on the Metallic Coating of the Ceramic Chamber for the ATF Damping Ring Kicker Magnets", in Proc. 16th Particle Accelerator Conf. (PAC'95), Dallas, TX, USA, May 1995, paper WAR03, pp. 1906-1908.

Content from this work may be used under the terms of the CC BY 3.0 licence (© 2019). Any distribution of this work must maintain attribution to the author(s), title of the work, publisher, and DOI