

Real time heat load calculation software based on EPICS for Fermilab PIP-II CM tests

S. Yoon, P. Hanlet, J. Makara, L. Pei, S. Ranpariya, P. Patel, J. Dong, D. Porwisiak, and M. White

Fermilab, Batavia, US

E-mail: sungwoon@fnal.gov

Abstract. Fermilab has a project to improve the proton beam energy which is called PIP-II (the 2nd Proton Improvement Plan). There is a superconducting linear accelerator, LINAC, to improve the proton beam power and the LINAC consists of 5 types of cryomodules (CM), 1 HWR CM, 2 SSR1 CM, 4 SSR2 CM, LB650 CM, and HB650 CM. The prototypes of these cryomodules are being tested at Fermilab's CryoModule Test Facility (CMTF). Heat load measurements are an important part of the prototype CM testing.

The CMTF cryogenic control system was developed based on the ACNET (Accelerator Control NETWORK) for CM testing for other projects, but the PIP-II cryogenic control system will be implemented using the Experimental Physics and Industrial Control System (EPICS). As part of the prototype CM testing campaign, an EPICS based control system has been implemented at CMTF. This EPICS cryogenic control system includes real-time heat load calculation software utilizing the Fortran implementation of Hepak.

This paper details the real time heat load calculation software developed for the prototype CM testing including the first results from the HB650 CM.

1. Introduction



Figure 1. PIP-II construction area (in April, 2025)

The slogan of PIP-II, Proton Improvement Plan II, project is “the future of Fermilab”. The goal of the PIP-II project is to construct an intense high-energy proton beam LINAC with beam power of up to 800 MeV. The beam from the LINAC will serve the international Deep Underground Neutrino Experiment, DUNE, at LBNF and the DUNE experiment system will be used for neutron applications.

Some prototype cryomodules for the LINAC were tested in the cryomodule test facility, CMTF, in Fermilab. Now their designs have been improved and upgraded based on the test results.

In 2024, a prototype of HB650 cryomodule which is one of 5 types of the cryomodules was tested in CMTF. The tests were done under a new integrated control system, Experimental Physics and Industrial Control System (EPICS) which is the standard control system of the PIP-II.

In EPICS, there was a chance to use the Hepak Fortran in real-time. It means that, during the test, EPICS can calculate all helium properties, like density, latent heat, and enthalpy, at any helium condition. (i.e., any temperature and any pressure)

With the Hepak Fortran under EPICS, the non-isothermal heat loads of the cryomodule were automatically calculated and showed the trend of the heat loads in real-time. The results from the EPICS were almost same as the results of the Excel spread sheet (dll file) with the archiving data.

This paper briefly introduces the CMTF in chapter 2 and the cryogenic control system in chapter 3. It explains how to measure the non-isothermal heat loads of the cryomodule in real-time with developed EPICS software in chapter 4 and shows the test results in chapter 5.

In chapter 6, it summarizes all and mention the plan of the software updates. The software will be improved to calculate the isothermal heat loads of the cryomodules, and it will calculate the total helium amount of the cryomodules in real-time.

The developed software can be applicable for the PIP-II LINAC cryogenic system.

2. Cryomodule test facility (CMTF)

2.1. Cryogenic system of CMTF

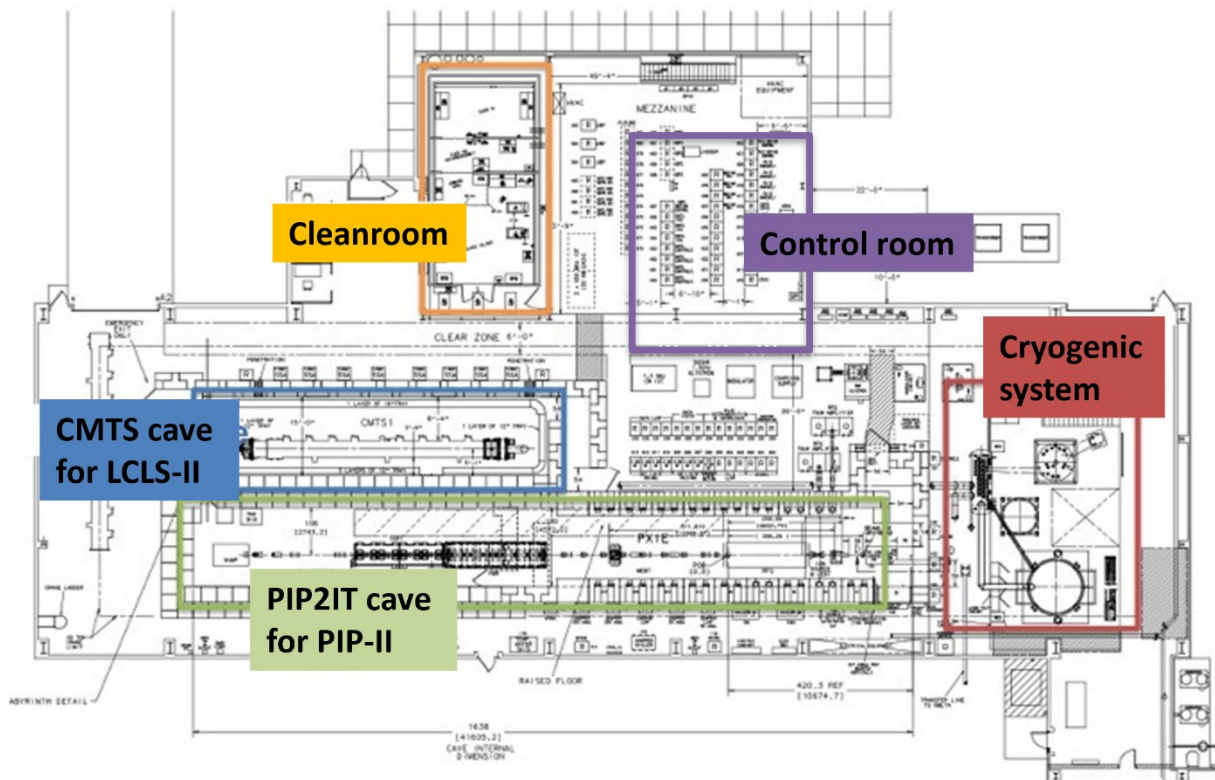

Figure 2. Layout of Cryomodule Test Facility, CMTF

For cryomodule tests, there is a cryogenic plant which is called “Superfluid Cryogenic Plant, SCP” and its cooling capacity is about 500 W at 2 K, 600 W at 5 K, and 5 kW at 40 K. The SCP fully supports any kind of cryomodules in test caves. [1] The cryogenic plant has three cold compressors and five warm vacuum pumps to keep the cryomodule temperature under 2 K. However, Fermilab installed three additional warm vacuum pumps and is using them without the cold compressors.

Also, there is a cryogenic distribution system to supply and return the cryogenic helium to/from the cryomodules in the caves. The distribution system consists of a distribution box, a valve box to control the DESY type cryomodule in a test cave and two small valve boxes for testing two cryomodules in the other test cave.

There are two separate cryogenic control systems. The SCP is controlled with WinCC under Siemens PLC and the other cryogenic system is working with Fermilab control system, Accelerator Control Network which is called ACNET. ACNET cannot control the SCP but can read all values of the SCP.

2.2. Test caves of CMTF

The cryomodule test facility, CMTF, in Fermilab has two test caves for testing different kinds of cryomodules. One of the caves, we call CMTS cave, is dedicated to the SLAC, LCLS-II HE cryomodules and the other cave, we call PIP2IT cave, is for the PIP-II cryomodules.

The cryogenic distribution system of the CMTS cave was designed for SLAC LCLS cryomodules. All LCLS-II cryomodules fabricated by Fermilab were successfully tested and now LCLS-II HE cryomodules for the beam energy upgrade, have been tested in this cave.

PIP2IT cryogenic distribution system can test two cryomodules simultaneously. There are two valve boxes for the two cryomodule and they can manage the cryogenic helium for both cryomodule.

2.3. Test schedule

There are five types of the cryomodules, a HWR cryomodule, SSR1 cryomodules, SSR2 cryomodules, LB650 cryomodules, and HB650 cryomodules.

In 2024, the prototype cryomodule of the HB650 cryomodules was tested in the PIP2IT cave and in 2025, the prototype of the SSR1 cryomodule will arrive at Fermilab for tests. Fermilab is preparing the test equipment and improve the cryogenic system.

3. Cryogenic control system in CMTF

3.1. Past, control system

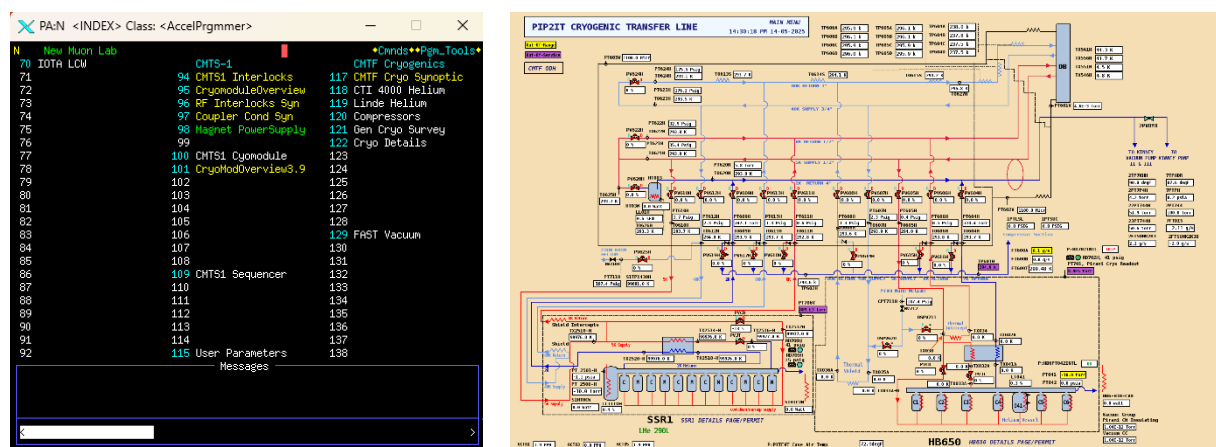

Figure 3. ACNET user interfaces (Left) and Synoptic user interfaces (Right) of cryogenic system

Accelerator Control Network, ACNET, is a main control system in Fermilab. All Fermilab control systems are based on ACNET and all beam lines and experiment systems are still controlled under this control system.

ACNET is a text-based interface and there is a Graphical User Interface, GUI, called Synoptic, between ACNET and operators.

The cryogenic system in the CMTF is displayed by Synoptic GUI and cryogenic operators can easily operate and monitor the system with Synoptic. [2]

3.2. Now, additional control system

Experimental Physics and Industrial Control System, EPICS, is the standard control system of the PIP-II. EPICS is developed as a control system for big science experimental system. It is an open-source software so it is possible to modify the EPICS for the CMTF cryogenic system.

The GUI of the EPICS was developed by the Phoebus and the GUI screens have updated before every cryomodule tests. With these screens, the cryomodule can be controlled. Figure 4 shows one of the GUI screens. [3]

3.3. Future, integration control system

The Accelerator Controls Operations Research Network, ACORN, [4] is the next control system for Fermilab accelerators. It will integrate the ACNET and EPICS and modernize the Fermilab accelerator control system by replacing the old hardware and software.

4. Real-time heat loads

4.1. Non-isothermal heat loads

Non-isothermal heat loads are calculated by the below equation.

$$W = \dot{m} \times (h_2 - h_1) \tag{1}$$

Where, W is the heat loads [W], \dot{m} is the mass flow rate, h_1 is the enthalpy at point 1 (inlet), and h_2 is the enthalpy at point 2 (outlet).

The cryogenic system measured the mass flow rate, pressure/temperature at point 1, and pressure/temperature at point 2. Based on the measured pressure and temperature, the enthalpy can be calculated by Hepak software.

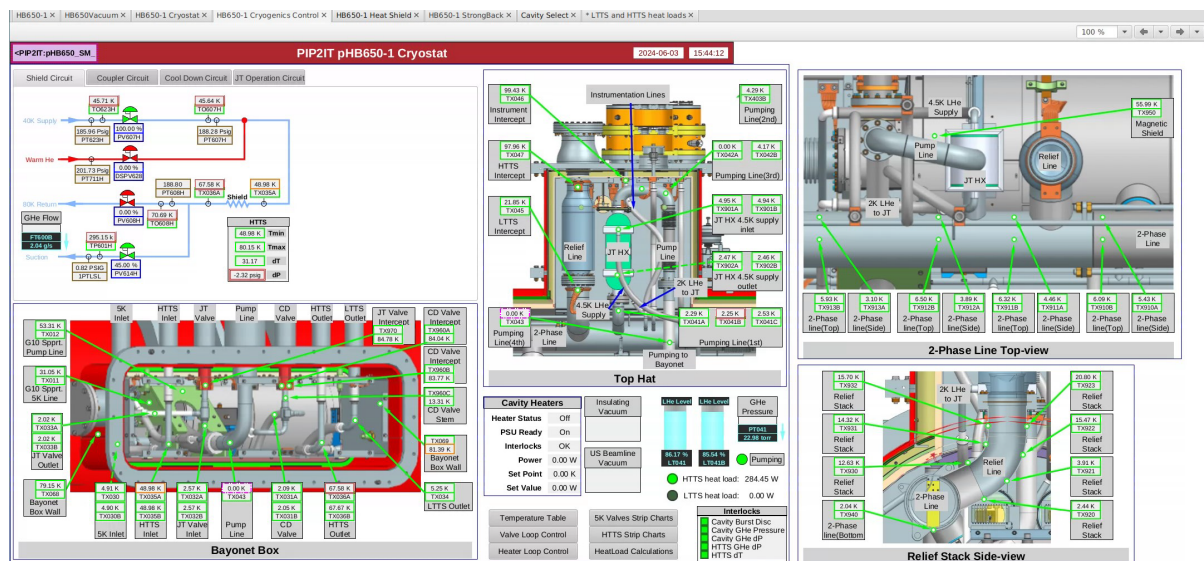

Figure 4. One of GUI screens for HB650 cryomodule tests in EPICS

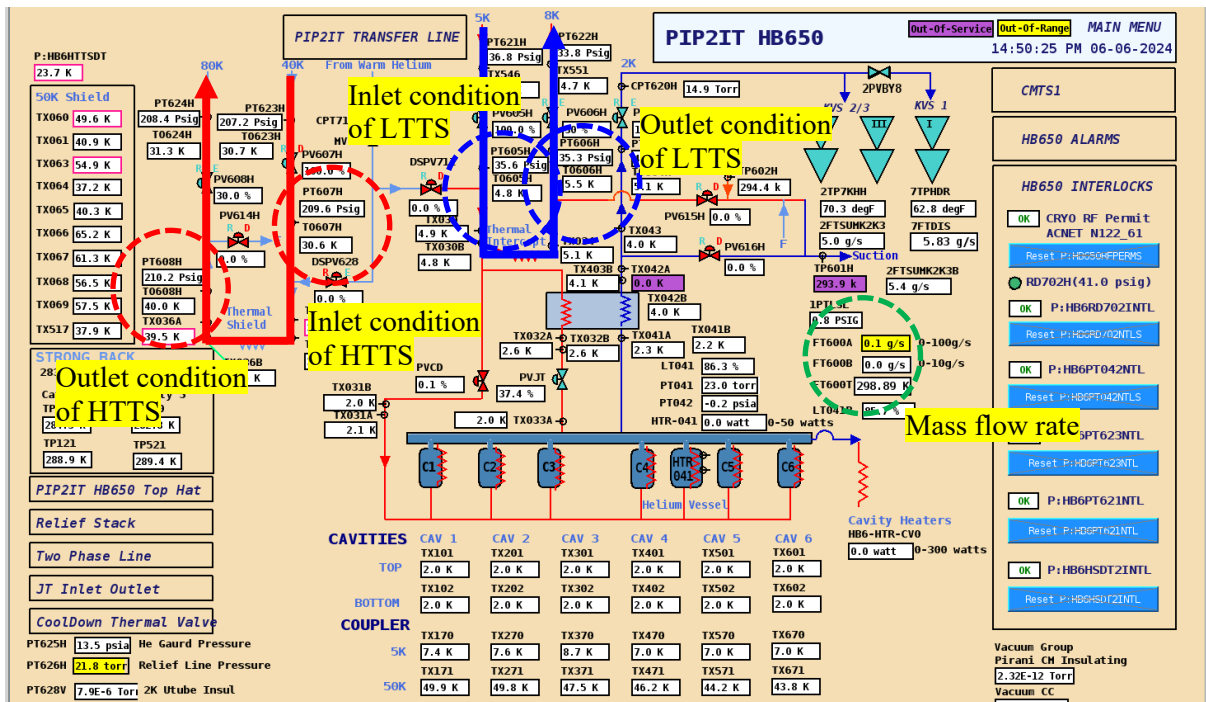

Figure 5. Heat loads measurement points (HTTS: red, LTTS: blue)

In case of the High Temperature Thermal Shield, HTTS, and the Low Temperature Thermal Shield, LTTS, of the prototype HB650 cryomodule, their heat loads can be calculated by the equation. The inlet/outlet points of the HTTS heat loads were defined as red circles in the Figure 5. Also, the inlet/outlet points of the LTTS heat loads were defined as blue circles in the figure. In both cases, they use the same flow meter, FT600A. (Green circle)

4.2. Helium properties with EPICS

Hepak has two different versions. One is for the excel spreadsheet and the other is Fortran version. EPICS can use the Hepak Fortran by C++ or the Python. The Fermilab EPICS source code was developed based on C++. [5]

$$q_{Total} = \dot{m} \times (h_{out} - h_{in}) = \dot{m} \times (h_{608} - h_{607})$$

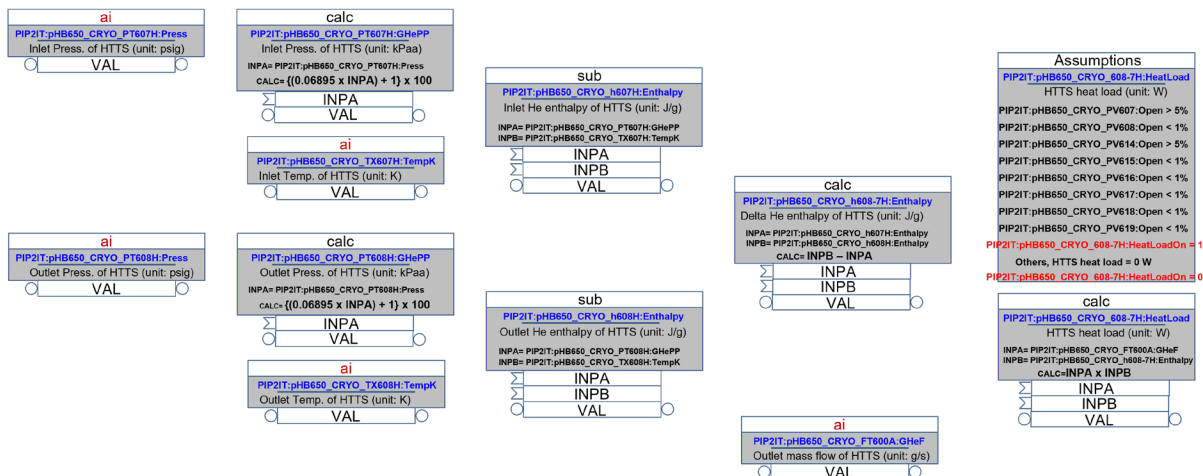

Figure 6. HTTS heat load calculation equations

Table 1. EPICS PV for heat load calculation

EPICS PV	Description	Unit	Remark
PIP2IT:pHB650_CRYO_PT607H:GHePP	HTTS inlet pressure	kPaa	Absolute press.
PIP2IT:pHB650_CRYO_h607H:Enthalpy	HTTS inlet enthalpy	J/g	
PIP2IT:pHB650_CRYO_PT608H:GHePP	HTTS outlet pressure	kPaa	Absolute press.
PIP2IT:pHB650_CRYO_h608H:Enthalpy	HTTS outlet enthalpy	J/g	
PIP2IT:pHB650_CRYO_h608-7H:Enthalpy	HTTS differential enthalpy	J/g	
PIP2IT:pHB650_CRYO_608-7H:HeatLoad	HTTS total heat load	W	
PIP2IT:pHB650_CRYO_PT605H:GHePP	LTTS inlet pressure	kPaa	Absolute press.
PIP2IT:pHB650_CRYO_h605H:Enthalpy	LTTS inlet enthalpy	J/g	
PIP2IT:pHB650_CRYO_PT606H:GHePP	LTTS outlet pressure	kPaa	Absolute press.
PIP2IT:pHB650_CRYO_h606H:Enthalpy	LTTS outlet enthalpy	J/g	
PIP2IT:pHB650_CRYO_h606-5H:Enthalpy	LTTS differential enthalpy	J/g	
PIP2IT:pHB650_CRYO_606-5H:HeatLoad	LTTS total heat load	W	
PIP2IT:pHB650_CRYO_608-7H:HeatLoadOn	HTTS heat load measurement on/off		Bool
PIP2IT:pHB650_CRYO_606-5H:HeatLoadOn	LTTS heat load measurement on/off		Bool
PIP2IT:pHB650_CRYO_PT607H:Press	HTTS inlet pressure	psig	Gauge press.
PIP2IT:pHB650_CRYO_TX607H:TempK	HTTS inlet temperature	K	
PIP2IT:pHB650_CRYO_PT608H:Press	HTTS outlet pressure	psig	Gauge press.
PIP2IT:pHB650_CRYO_TX608H:TempK	HTTS outlet temperature	K	
PIP2IT:pHB650_CRYO_PT605H:Press	LTTS inlet pressure	psig	Gauge press.
PIP2IT:pHB650_CRYO_TX605H:TempK	LTTS inlet temperature	K	
PIP2IT:pHB650_CRYO_PT606H:Press	LTTS outlet pressure	psig	Gauge press.
PIP2IT:pHB650_CRYO_TX606H:TempK	LTTS outlet temperature	K	
PIP2IT:pHB650_CRYO_FT600A:GHeF	LTTS/HTTS mass flow rate	g/s	

4.3. Real-time heat load measurement

To develop the source code of the heat load calculation, first, all EPICS Process Variables, PV, were defined. Table 1 shows all necessary PV. Second, the calculation equations were defined as Figure 6 and Figure 7. [6] Third, the GUI was developed by the Phoebus.

5. Results

The prototype HB650 cryomodule was tested in the PIP2IT cave. There were various tests including the heat load measurement.

$$\dot{q}_{total} = \dot{m} \times (h_{out} - h_{in}) = \dot{m} \times (h_{606} - h_{605})$$

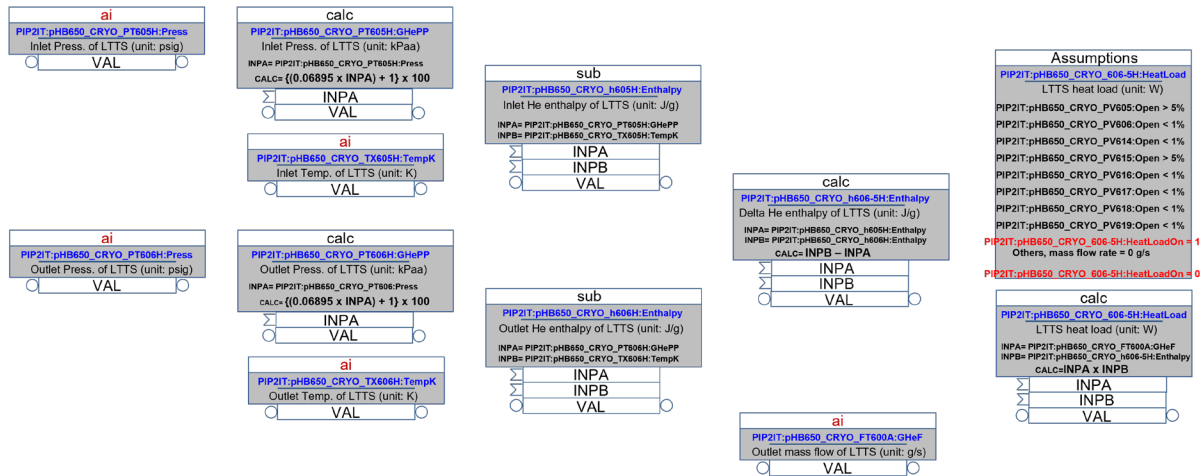

Figure 7. LTTs heat load calculation equations

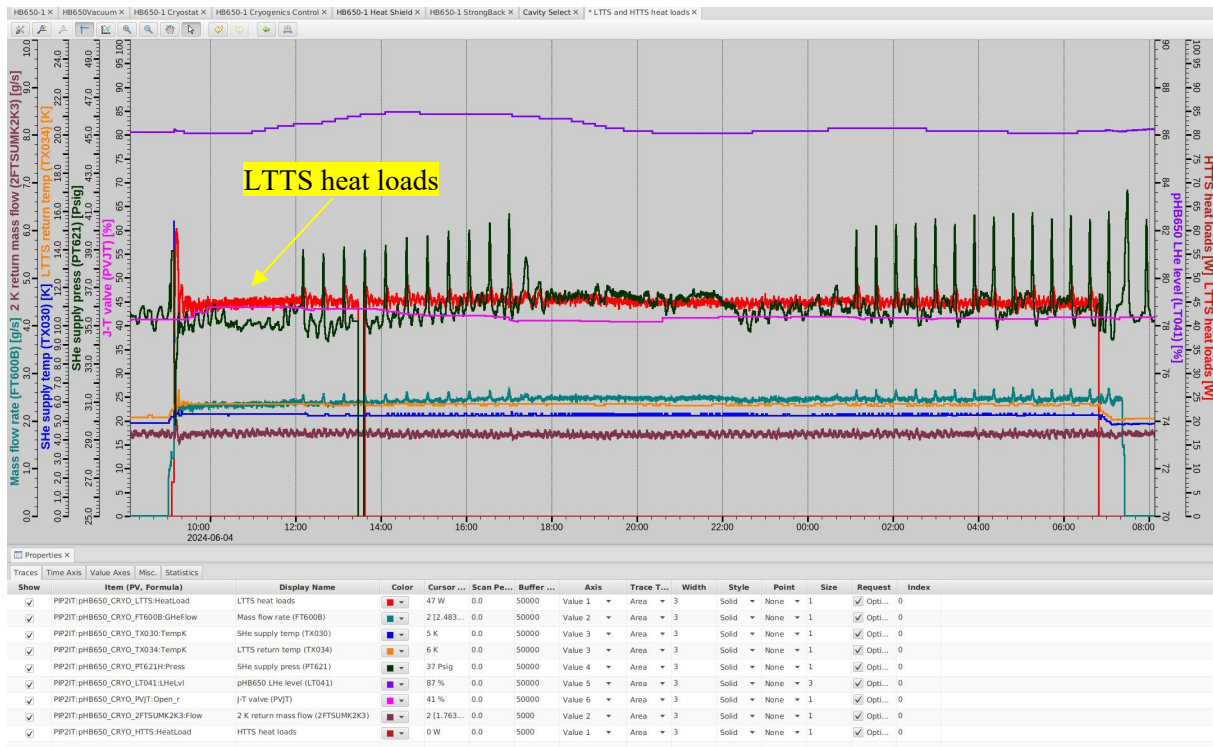

Figure 9. LTTs heat load results in real-time

7. References

- [1] M. J. White et al 2018, IOP Conf. Series: Materials Science and Engineering 101 (2017) 012098
- [2] L. Pei et al 2018, IOP Conf. Series: Materials Science and Engineering 278 (2017) 012188
- [3] P. Hanlet et al 2024, JACoW ICALEPSC2023 (2023)TUMBCMO20
- [4] D. Finstrom et al 2024, JACoW ICALEPSC2023 (2023)TUMBCMO20
- [5] S. LEE Ph. D dissertations (2022) Chungnam national Univ. in S. Korea
- [6] S. YOON et al 2020, Trans. Korean Soc. Mech. Eng. B, Vol. 44, No. 8, pp. 511-517 (2020)
- [7] D. Porwisiak et al, CEC/ICMC2025 proceeding
- [8] P. Hanlet et al, ICALEPS2025 presentation

Acknowledgements

This manuscript has been authored by Fermi Research Alliance, LLC under Contract No. DE-AC0207CH11359 with the U.S. Department of Energy, Office of Science, Office of High Energy Physics. The authors wish to recognize the dedication and skills of APS-TD/Cryogenics technical staff involved in the installation and commissioning of this system.