

## Some Alignment Considerations for the Next Linear Collider

Robert E. Ruland, Stanford Linear Accelerator Center, Stanford, CA 94309

### 1.0 INTRODUCTION

Next Linear Collider type accelerators require a new level of alignment quality. The relative alignment of these machines is to be maintained in an error envelope dimensioned in micrometers and for certain parts in nanometers. In the nanometer domain our terra firma cannot be considered monolithic but compares closer to jelly. Since conventional optical alignment methods cannot deal with the dynamics and cannot approach the level of accuracy, special alignment and monitoring techniques must be pursued.

### 2.0 COMPONENT PLACEMENT TOLERANCES

Component placement tolerance specifications define the alignment operation. The definition of these tolerances has changed over recent years, resulting in significantly looser specifications. At the same time, the alignment requirements of NLC type machines are intrinsically more demanding, effectively offsetting these reductions.

The available space here does not allow a detailed discussion of all parts of an NLC design. While the following discussion will focus on the main linac damping ring alignment, most of it is nonetheless directly applicable to the other machine parts.

#### 2.1 Definitions

Originally, alignment tolerances were calculated as the offset of a single component resulting in an intolerable loss of luminosity. This seemed a reasonable way to proceed and immediately gave relative sensitivities of component placement. However, this method had two flaws: it failed to take into account that, firstly, not just one but all elements are out of alignment simultaneously, and secondly, that sophisticated orbit and tune correction systems are applied to recover the lost luminosity. Permissible alignment errors, random or systematic, under these more realistic assumptions are much harder to estimate because they require an understanding of all

Work supported in part by the Department of Energy contract DE-AC03-76SF00515.

*4th International Workshop for Accelerator Alignment,  
Tsukuba, Japan, November 14-17, 1995*

conceivable interactive effects that go into a simulation and a detailed scenario of tuning and correcting. The continued increase in available computing power has made it possible to calculate the simultaneous offsets of all components. Operating experience from the present generation of colliders has yielded significant advances in orbit tuning and correcting. On this basis, alignment tolerances can be defined as the value of placement errors which, if exceeded, make the machine uncorrectable. Experience with higher order optical systems has shown that alignment tolerances derived in this manner tend to be about an order of magnitude looser than before.'

## 2.2 NLC Linac Tolerances

Alignment tolerances according to the first and the most recent definitions have been computed<sup>2</sup> and are plotted in Fig. 1. The first curve shows the placement tolerances required to keep dispersion losses under a tolerable 3%, i.e. the machine would operate to design specifications. The placement requirements for adjacent components are a very tight 3  $\mu\text{m}$ . Fortunately, the tolerances are scale dependent. The most stringent placement is required only for components within about 160 m of the point of investigation; further downstream the tolerances quickly drop off. The second curve shows the tolerance which, if exceeded, would make the machine uncorrectable. Here, we see the same scale dependency.

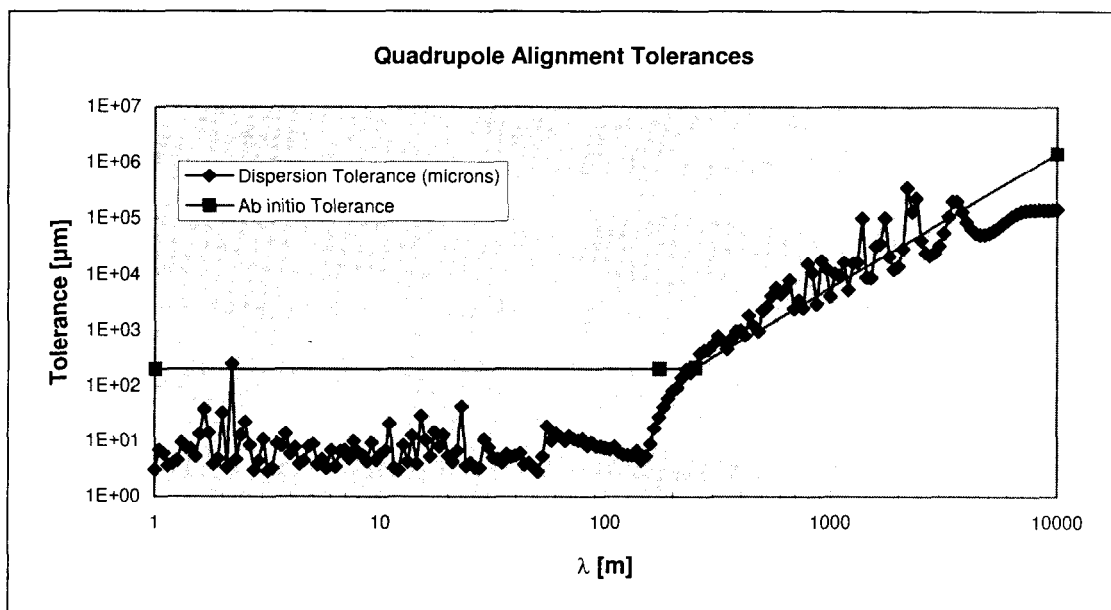

Fig. 1. Quadrupole alignment tolerances--running conditions

### 2.3. Measurement Quality Estimate

To estimate what alignment accuracy could be achieved in a conventional alignment procedure for the main linac, the process has been simulated. Fig. 4 shows the resulting tolerance curve. Comparing Fig. 1 to Fig. 2, one can see, that conventional alignment can support the *ab initio* alignment requirements but not the running tolerance requirements.

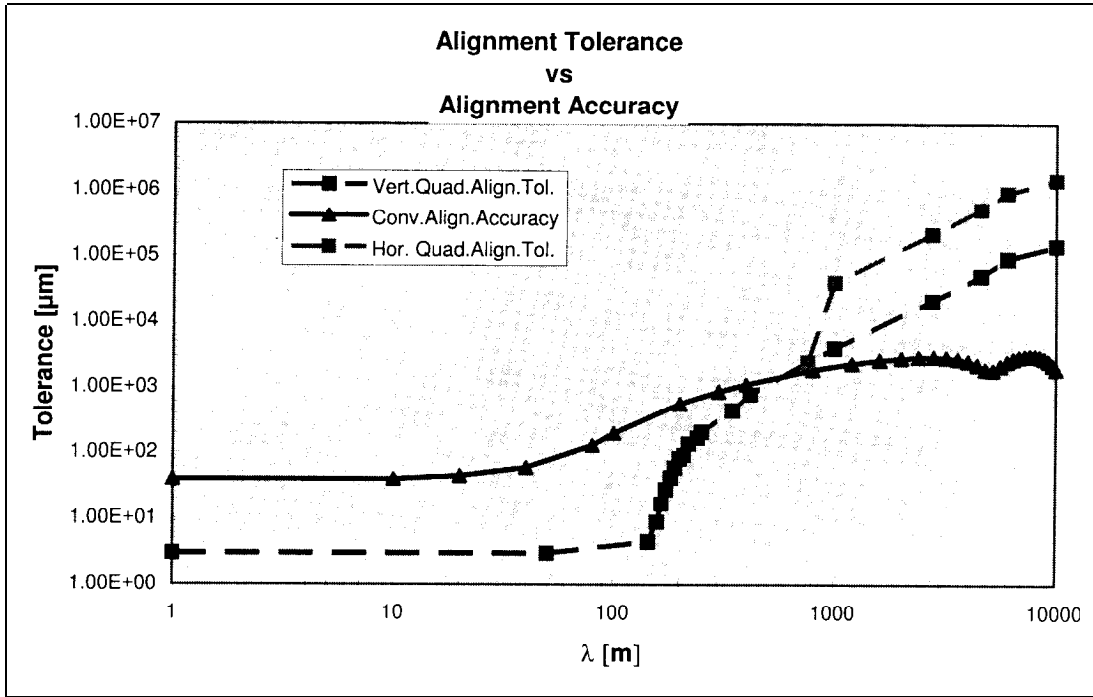

Fig. 2. Quadrupole alignment tolerances vs. alignment accuracy

### 3.0 DATUM DEFINITION

Since the earth is spherical, a slice through an equipotential surface, i.e. a surface where water is at rest, shows an ellipse. For a project the size of an NLC, this has significant consequences.

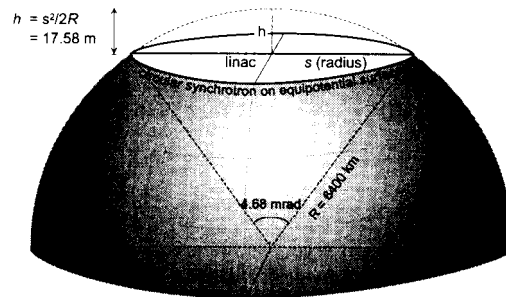

Fig. 3. Effect of earth curvature on linear and circular accelerators

### 3.1 Tangential Plane or Equipotential Surface

Traditionally, accelerators were built in a tangential plane, sometimes slightly tilted to accommodate geological formations. All points around an untilted circular machine lie at the same height (Fig. 3), but a linear machine such as the NLC cuts right through the equipotential iso-lines. The center of a 30 km linear accelerator is 17 m below the end points. To alleviate the problems one could build the accelerator on more than one plane, e.g. building the linacs and the final focus/detector section on three separate planes reduces the sagitta to 1.9 m (Fig. 4). To avoid the “height” difference completely, one would need to build the machine along an equipotential surface.

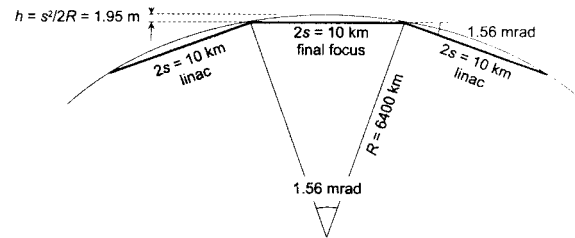

Fig. 4. Three plane lay-out

### 3.2 Lay-out Discussion

Since most surveying instruments work relative to gravity, the “natural” solution is a lay-out which follows the surface generated by equal gravity, the equipotential surface, although, for conventional alignment methods, the choice of a tangential surface adds just one additional correction. The choice of lay-out surface does have a major impact upon which special alignment methods can be used: a diffraction optics Fresnel plate alignment system requires a straight line of sight, but a hydrostatic level system can not accommodate height differences of more than a few centimeters.

## 4.0 SPECIAL ALIGNMENT SYSTEMS

The conventional alignment accuracy can be improved by adding alignment systems to the measurement plan which are optimized for the measurement of the critical dimension. The key element of any of these alignment schemes is to generate a straight line reference. Fig. 5 gives an overview of straight line reference systems categorized by their working principle.<sup>3</sup> Most of these systems can also be used to establish on-line monitoring systems.

### 4.1 Mechanical Reference Line

A stretched wire is used to represent a straight line. While in the horizontal plane a wire projects to a first order a straight line, in the vertical plane it follows a hyperbolic shape due to

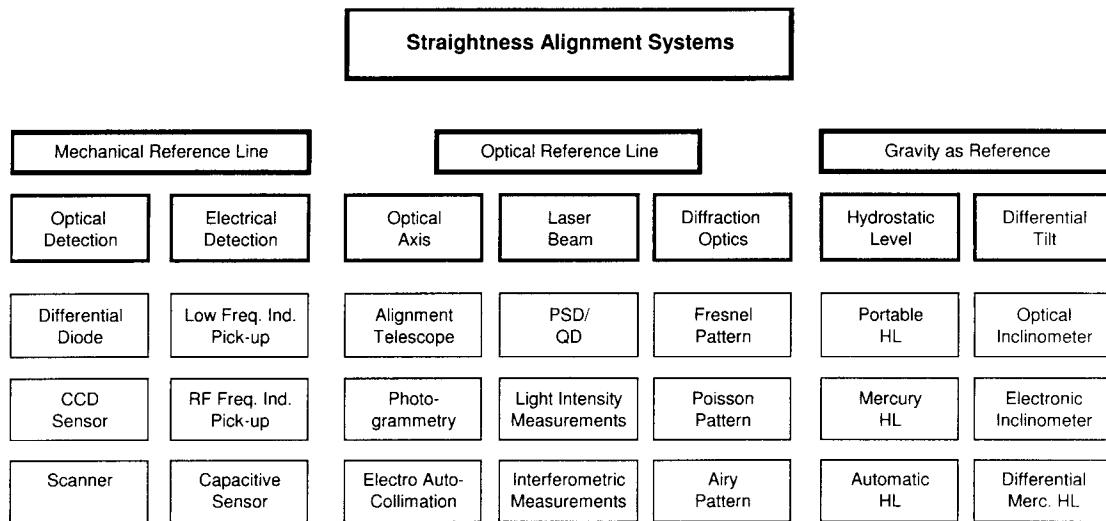

Fig. 5. Straight line reference systems

gravitational forces. The deviation from a straight line in the vertical is a function of the wire's weight per unit length, wire length and tension. A 45 m spring steel wire with 0.5 mm diameter under a maximum tension has a sagitta of about 6 mm. A comparable wire made of a silicon-carbide material<sup>4</sup> which has the same tensile strength but at only one tenth of the spring steel's weight per unit length, creates a sagitta of only 0.6 mm. For very accurate measurements, deviations of a wire from a straight line in the horizontal plane must also be considered. These deviations are created by internal bending moments caused by molecular stress of the material. The bending moments can be reduced to negligible size by heat-treating the wire or by stretching it into the yield range.

#### 4. 1. 1. Optical Detection The "Light Shadow Technique"

(Fig. 6) is implemented with a variety of detectors and can provide very cost effective solutions, excellent range and resolution. At LLNL, a GaAs infrared emitting diode

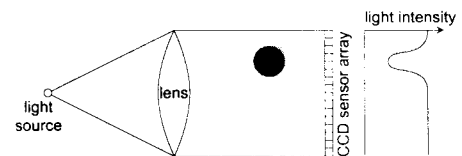

Fig. 6. Light shadow technique

illuminating a silicon phototransistor across a 2.5 mm gap combination was used to measure the deflection of a wire in an electro-magnetic field.<sup>5</sup> This set up was part of a system to align the solenoid focus magnets on the ETA-II linear induction accelerator. To stabilize drift problems, the phototransistor was replaced with CdS photoconductors.<sup>6</sup> The resolution proved better than 1  $\mu\text{m}$  and unit cost were less than \$50. Another example is the centering system implemented for the CERN Ecartometer<sup>7</sup>. Its centering accuracy is better than 20  $\mu\text{m}$ .

4.1.2. *Electrical Detection* Electrical pick-ups use inductive or capacitive techniques to measure the wire position. A very simple inductive system was developed at KEK to support the alignment of the ATF linac. The reference wire carries a 60 kHz signal which is picked up by two coils on either side of the wire (Fig. 8).<sup>8</sup> The differential signal is a measure for the relative wire position. The accuracy over the measurement range of 5 mm is better than  $\pm 30 \mu\text{m}$ . The system developed by DESY for SLAC (Fig. 9) transmits a 140 MHz signal over the wire which is received by the wire position monitor antenna strips. The relative signal from diametrically opposing antennas is a measure of the wire position. The system is bi-axial, has a range of 2 mm, and at 8 mm object distance provides long term position accuracies of better than  $\pm 1 \mu\text{m}$ .<sup>9</sup> ESRF and CERN, in collaboration with the French company Fogale Nanotech, have developed capacitive sensors. The CERN sensor is bi-axial and resolves the wire position over a range of 2.5 mm to  $\pm 1 \mu\text{m}$ .

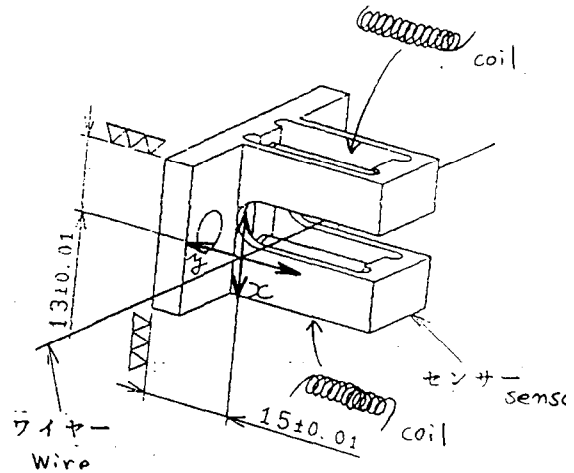

Fig. 8. KEK inductive wire sensor

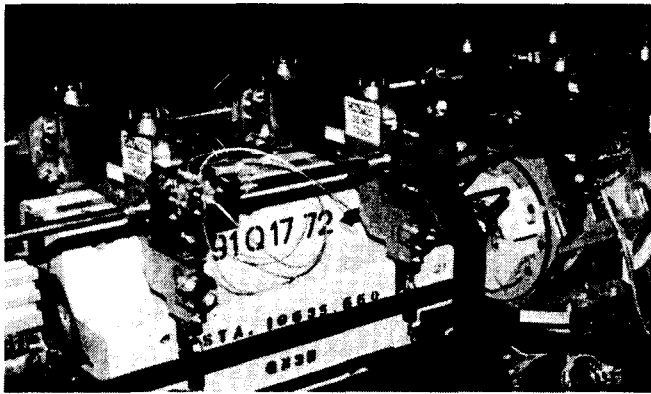

Fig. 8. FFTB magnets with wire system and magnet mover



Fig. 9. Fogale Nanotech capacitive sensor

## 4.2. Optical Reference Line

4.2.1 *Optical Axis Reference* The optical axis is the reference line to which components are positioned using traditional alignment instruments. Alignment telescopes can support the manual

alignment of components to about  $\pm 50 \mu\text{m}$ . The target acquisition can be automated by replacing the observer's eye with a CCD camera and applying image processing technique. Because the range is very limited, this incarnation of the technique doesn't lend itself to a NLC machine alignment application. However, the same basic idea is implemented in a very different way in the SLAC Pyramid Target Monitoring System<sup>10</sup>. Basically, a standard CCD camera fitted with an appropriate length lens takes pictures of the target. The target is designed to optimize the resolution of image processing techniques to distinguish any change of the target's position in its 6 degrees of freedom. The target is three-dimensional; it is a box topped with a right regular pyramid. (Fig. 10).

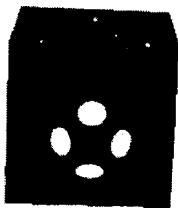

Fig. 10 SLAC Pyramid Magnet Monitoring System Target

Each of the four sides of the pyramid has one circle about 2 cm in diameter machined into the surface so that lighting from behind illuminates light-diffusing plastic plugs inserted flush into each hole. When the target is viewed end on, all four circles are visible. They will actually appear as ellipses where the top and bottom ellipses will have their major axes oriented horizontally and the two side ellipses have their major axes located vertically. This creates the fundamental feature enabling us to monitor rotational changes. Typical image filtering to enhance contrast is followed by a template matching step gaining under normal conditions a sub-pixel resolution of about one fifth of a pixel. This translates with 2 m object distance to about  $10 \mu\text{m}$  resolution in object space.

4.2.2. *Laser Beam Reference* In its simplest form, a laser beam images a spot on a PSD, QD or CCD array, allowing a direct position read-out to few  $\mu\text{m}$ . The relative motion of adjacent girders in the KEK ATF is monitored by a laser/PSD combination. A diode laser beam is split into two arms, each creating a signal on a PSD. A relative girder motion results in two displacement vectors. Their analysis yields three translations and roll.<sup>11</sup> To compensate for instabilities of the laser, reference position detectors allow differential measurements (Fig. 11).

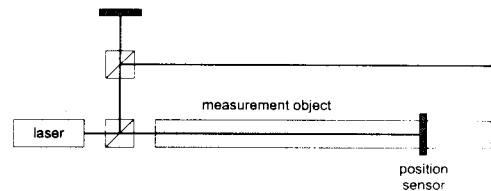

Fig. 11. System with compensation

4.2.3. *Diffraction Optics Reference* While the above methods are well suited for short to medium ranges, diffraction optics methods can provide a straight reference line over kilometers, e.g. the

SLAC Linac/FFTB Alignment System.<sup>12,13</sup> The reference line of a Fresnel system is defined by the pin hole and the center of the detector plane (Fig. 12). The Fresnel zone

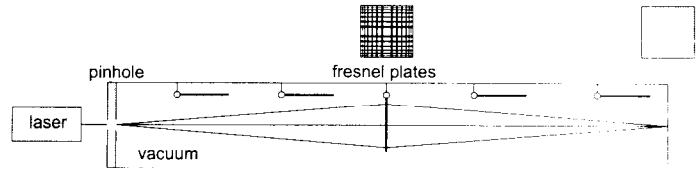

Fig. 12. Fresnel alignment system

plate (Fig. 13) focuses the diffuse light onto the detector, forming an interference pattern (Fig. 14). The design parameters of the zone plates, size, width of strips, and gaps, are a function of the wavelength of the light source, image and object distances, and resolution. Only one Fresnel lens can be in the light path at any time. To incorporate more monitor stations into the system, the zone plates must be mounted on hinges so that actuators can flip the plates in and out of the light path. Since refraction would distort the fringe images to noise, the light path must be in a vacuum vessel.

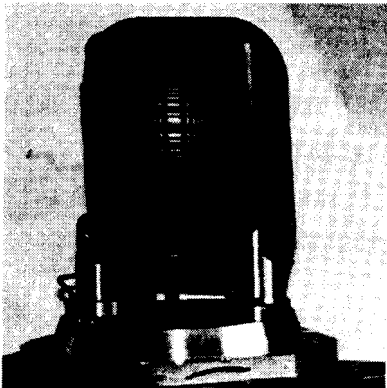

Fig. 13. Hinged Fresnel zone plate

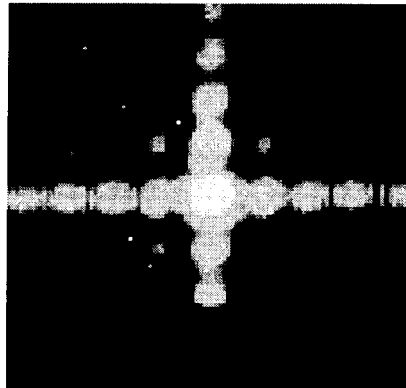

Fig. 14. Fresnel zone plate image

The FFTB alignment system's Fresnel zone plates, which, as an extension to the linac alignment system, are about 3.2 - 3.4 km from the detector, can resolve the motion of a zone plate to 5  $\mu\text{m}$ .

Another method of generating the straight line reference by diffraction is the Poisson line.<sup>14</sup> An opaque sphere illuminated by a plane wave generates a diffraction pattern behind the sphere. This pattern can be observed by placing an observation screen or camera in any plane behind the sphere. The Poisson reference line passes through one fixed point, the center of a sphere. The second point is formed by centering the Poisson spot on a quadcell in the detection plane, using a feedback circuit between the quadcell and the mirror that actively steers the incident plane wave. An advantage of the Poisson scheme is the possibility to place several spheres simultaneously into a very large diameter beam. More spheres can be incorporated by mounting individual spheres to hinged frames similar to the Fresnel system, so as to measure different sets of spheres.

### 4.3. Gravity as Reference

A surface of equal “gravity” on which every point is the same height is called an equipotential surface. A hydrostatic level, in which an enclosed body of fluid conforms to an equipotential surface, is a very accurate tool to transfer a height from one point to another or to monitor height changes. Systems are available in different flavors: with optical, mechanical or electrical sensors; manual or computerized; with different fluid+ water, oil, or mercury; portable or stationary. ESRF has developed a hydrostatic level system for on-line monitoring of magnet height changes (Fig. 15). To monitor the water level the system uses capacitive proximity gages interfaced to a control system. If significant height changes have been determined, the control computer activates motorized jacks to compensate for the changes. Measurement accuracies of  $\pm 5 \mu\text{m}$  over 1 km have been reported.<sup>15</sup>

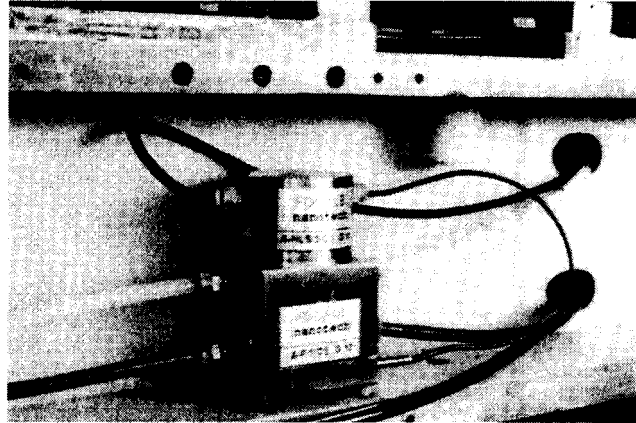

Fig. 15 ESRF Hydrostatic Level System

## 5.0 ERROR PROPAGATIONS WITH ADDITIONAL SYSTEMS

### 5.1. Stretched Wire

For the purpose of estimating the error propagation of a wire system over the length of a possible NLC linac the lay-out as sketched in Fig. 16 was assumed. A double overlapping wire arrangement is necessary since it was found that in order to preserve a position survey accuracy of  $\pm 5 \mu\text{m}$  the wire length must not exceed 100 m. Fig. 17 shows the resulting error estimates. The present wire curve is based on propagating linearly the FFTB wire accuracy to a length of 100 m. It is encouraging to see that an existing technology is almost able to support the operations tolerance.

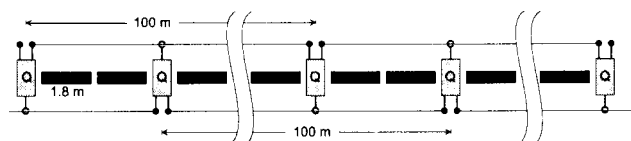

Fig. 16. Double-wire lay-out

The improved wire curve assumes that it will be possible to achieve the present FFTB wire accuracy for a 100 m long wire. This system would be able to fully support the alignment needs.

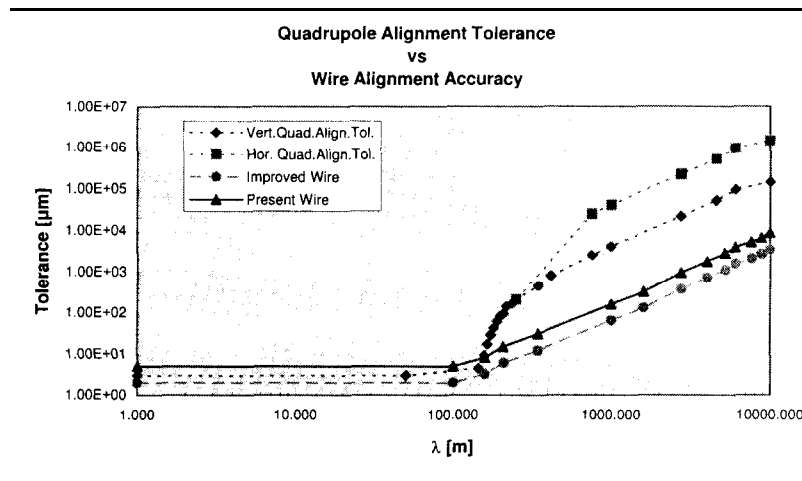

Fig. 17. Wire alignment accuracies

## 5.2. Hydrostatic Level System

To simulate the effect of supporting the alignment with a hydrostatic level system, two cases need to be considered. If the machine would be built on a tangential plane, one hydrostatic level system cannot accommodate the height difference. Therefore, the simulation assumes individual 500 m long sections set up like a stair. The second case assumes an equipotential surface as reference plane allowing one continuous system. Fig. 18 shows the simulation results.

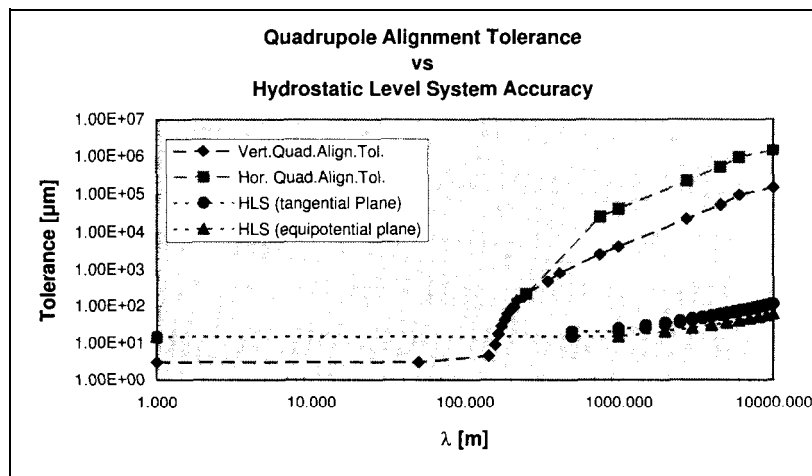

Fig. 18. Hydrostatic alignment accuracies

## 6.0 SUMMARY

Although the NLC requires alignment tolerances an order of magnitude tighter than required for existing machines, results from a conventional alignment will be sufficient to make the NLC correctable. It was shown also that more sophisticated alignment systems can very likely accommodate the operational requirements. While the beam itself is the ultimate judge of alignment, beam based alignment requires costly beam time. To maximize luminosity, the investment in more sophisticated alignment tools may well pay off.

---

<sup>1</sup>Fischer, G., Alignment and Vibration Issues in TeV Linear Collider Design, *Proc. International Conference on High Energy Accelerators*, Tsukuba, 1989, SLAC-PUB 5024.

<sup>2</sup>Adolphsen, C., A Linac Design for the NLC, *Proc. 1995 PAC*, Dallas, 1995, in print.

<sup>3</sup>Schwarz, W. ed., *Vermessungsverfahren im Maschinen- und Anlagenbau*, Schriftenreihe DVW, Wittwer Verlag, 13/1995, p. 128.

<sup>4</sup>Made by TEXTRON Specialty Materials.

<sup>5</sup>Griffith, L., Progress in ETA-II Magnetic Field Alignment using Stretched Wire and Low Energy Electron Beam Techniques, *Proc. Linac Conference*, Albuquerque, 1990.

<sup>6</sup>Griffith, L., private communication.

<sup>7</sup>Gervaise, J. & E. Wilson, High Precision Geodesy Applied to CERN Accelerators, *Applied Geodesy for Particle Accelerators*, CERN 87-01, Geneva, 1987, p. 162.

<sup>8</sup>Hayano, H., private communication.

<sup>9</sup>Ruland, R., et al., A Dynamic Alignment System for the Final Focus Test Beam, *Proc. Third IWAA, Annecy*, 1993, pp. 243-4.

<sup>10</sup>Fuss, B., The SLAC Pyramid Magnet Monitoring System, *Internal Report, Unpublished*

<sup>11</sup>Takeuchi, Y., ATF Alignment, *Proc. KEK/SLAC X-Band Collider Design Mini-workshop*, SLAC, 1994, SLAC-R-95-456.

<sup>12</sup>Hermannsfeldt, W., Precision Alignment Using a System of Large Rectangular Fresnel Lenses, *Applied Optics*, 7, 1968, pp. 995-1005, SLAC-PUB 496.

<sup>13</sup>Ruland, R., op.cit., pp. 246-251.

---

<sup>14</sup>Griffith, L., et al., Magnetic Alignment and the Poisson alignment reference system. *Rev. Sci. Instrum.*, 61 (8), 1990, pp. 2138-2154.

<sup>15</sup>Roux, D., A historical First on Accelerator Alignment, *Proc. Third IWAA*, Annecy, 1993, pp. 88-91.