

СООБЩЕНИЯ
ОБЪЕДИНЕННОГО
ИНСТИТУТА
ЯДЕРНЫХ
ИССЛЕДОВАНИЙ

Дубна

E1-2012-78

A. M. Makankin, V. V. Myalkovskiy,
V. D. Peshekhonov *, S. E. Vasilyev

A DIRECT TIMING METHOD
FOR THE TWO-DIMENSIONAL PRECISION
COORDINATE DETECTORS BASED
ON THIN-WALLED DRIFT TUBES

* E-mail: Vladimir.Peshekhonov@sunse.jinr.ru

INTRODUCTION

The determination of the momentum of charged particles moving in a magnetic field assumes a precision measurement of spatial coordinates in the bending plane of the magnetic field whereas the precision of the measurement of the track incident angle is less important. In a gaseous drift chamber a high precision coordinate in the plane orthogonal to the anodes is determined by measuring a drift time of ionization electrons created by charged particles crossing a detector. The determination of the coordinate along the anode direction can be accomplished by using several methods. For example, the strip cathode readout is widely used [1, 2], and two coordinate drift chambers with pad readout are being developed [3, 4]. These techniques can also be employed for the coordinate detectors based on the thin-walled straw tubes, however, in this event the resistivity of cathodes should be higher than 100 k Ω /square. Moreover, the charge collection time should be higher [1–3].

The longitudinal coordinate can be measured in a straw by the method of the charge division in which the signals are read out from two ends of the resistive anode wire. The highest spatial resolution which can be achieved by this method has been obtained by employing measurements based on time-dependent charge asymmetry [5]. In this case, the anode resistivity was 400 Ω /m and the spatial resolution (r.m.s.) reached 0.95 cm at the middle and about 2.5 cm near the ends of a 1.52 m long straw when 5.9 keV gammas were registered. However, when minimum ionizing particles were detected, the resolution deteriorated from 2.5 to 6 cm, respectively [5].

As demonstrated in [6], the measurements of the longitudinal coordinate by using drift tubes can be realized by the method in which the difference of signal arrival time at the amplifiers directly connected to ends of the anode wire is measured. The method is called direct timing method (DTM) [6]. The anode wire is considered in this case as a transmission line.

This paper presents the results obtained by employing the DTM technique for registering signals from a coordinate prototype detector based on 2 m long straw tubes. An important feature of the detector prototype is a possibility of operation at a gas pressure of 4 bar as well as a special design of the gas manifold which allows mounting the readout boards close to the ends of the anode wires.

1. THE SETUP

The detector prototype includes a layer of glued straw tubes with an inner and outer diameters of 9.56 and 9.68 mm, respectively. A 2 m long straw is made by winding two Kapton strips. The inner strip is a carbon loaded Kapton conductive film of XC-160 type, whereas the outer strip is Kapton aluminized film of HN50 type [7]. The anode is made of 31 mkm gold-plated tungsten wire which has a resistivity of $70 \Omega/\text{m}$ and is installed under the tension of 70 g with one polycarbonate spacer at the middle of the straw tube. The transmission line impedance is 360Ω . The tubes were flashed with the Ar/CO₂ (80/20) gas mixture at the pressure of 1 or 3 bar.

Characteristics of the DTM technique with respect to the longitudinal coordinate resolution were studied both with the gas gain of $\sim 7 \cdot 10^4$ and in the high-current mode with the anode voltage of 3.05 kV. The transverse coordinate resolution obtained earlier in the latter operation mode has been found to be better than 50 mkm [8].

The layout of the experimental setup is shown in Fig. 1. A straw under study has been irradiated either with 5.9 keV gammas from a ⁵⁵Fe gamma-ray source or with beta rays from ¹⁰⁶Ru source through the slit collimators. In the latter case, the electrons passing through the straw have been detected by a scintillation counter with two PM. Low-energy electrons have been stopped in an absorber located between a straw and a counter.

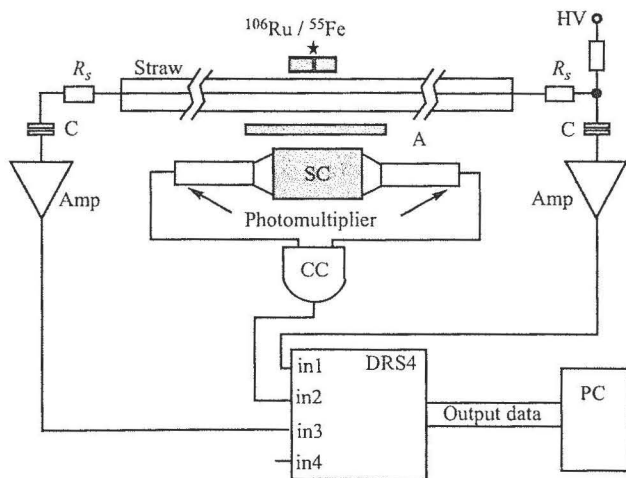

Fig. 1. Schematic layout of the setup. A — absorber, SC — scintillation counter, Amp — amplifier, CC — coincidence circuit, DRS4 — Domino Ring Sampler

Amplifiers based on a MSD-2 microcircuit with a gain of $35 \text{ mV}/\mu\text{A}$ and a rise time of about 4 ns, an input impedance of 120Ω [9] are installed close to the ends of the anode wire connected with minimum parasitic capacitance and inductance.

The pulses from the outputs of the amplifiers are fed into two channels (1 and 3) of the DRS4 amplitude-to-digit convertor which can digitize an input signal providing the sampling speed of 5 GS/s and store an amplitude and a pulse shape in a time window of the size determined by the DRS4 board memory (1024 words — 200 ns) [10]. The maximal amplitude of the input pulses is $\pm 0.5 \text{ V}$. The data arriving at DRS4 is processed according to the following algorithm:

- selection of the correlated pulses by introducing a threshold for the incoming anode pulses, and by requesting a signal from the scintillation counter arriving at the second DRS channel in the case of measurements with the ¹⁰⁶Ru source;
- determination of the pulse amplitudes in the software time window and its normalization on the maximum pulse height of the smallest pulse;
- linear approximation of the leading edge in the time interval between T_l and T_b levels determined by the software as a percentage of the highest pulse amplitude;
- determination of the arrival time for each pulse as the intersection point of the approximated line and time axis;
- plotting a histogram of the time delay difference between pulses (δt) and evaluation of mean values and r.m.s.

If the point of the avalanche origin is displaced along the anode wire by δy from its middle, the two signals arriving at amplifiers pass the distance $L/2 + \delta y$ and $L/2 - \delta y$, where L is the anode length. Therefore, the absolute difference δt is determined as $\delta t = 2\delta y/v$, where v is the signal propagation velocity along the anode wire, whereas the sign determines the direction of the coordinate displacement with respect to the middle of the wire.

The tests for stability of the clock generator have demonstrated that the generator random jitter is of the order of 1% which corresponds to 70 ps for the range of measurements under study. This DRS4 frequency jitter resulted in deterioration of the accuracy in the measurements of the arrival time difference δt for two signals as a function of δt . In order to reduce the uncertainty in measurements of δt during displacement of the collimated source along the straw, the calibrated cable delay has been introduced in one of the channels which provided measurement conditions in which δt was close to zero. This delay was subsequently taken into account. One can suggest at least two ways of reducing this uncertainty. In the first approach, reducing the jitter by the factor of 3–5 can remove the impact of the jitter on the measurement accuracy. The second approach relies on determining of the correction coefficient intro-

duced into generator frequency for each measurement. To this end, a couple of signals correlated in time with the measured signals by the external triggering signal which has a well-defined time shift can be fed to one of the DRS input channels.

2. LONGITUDINAL SPATIAL RESOLUTION

A ^{55}Fe gamma-ray source has been used both in the studies of the DTM technique and in ultimate measurements. The parameters of amplifiers have been determined for the source position at the middle of the straw. Then, the scan along the straw allowed for the measurements of the attenuation in the signal amplitude and the signal propagation velocity along the anode wire. Typical signals shown in Fig. 2, *a* demonstrate a good uniformity of the amplifier parameters. Pulses registered by an amplifier when the gamma-ray source is located at the end of the straw tube are displayed in Fig. 2, *b*. The attenuation of the signals as a function of the distance between the source and the straw end is shown in Fig. 2, *c*. Apparently, the signal attenuation factor at the length of 1.94 m is 2.17 and the signal propagation velocity is 3.49 ns/m.

If the longitudinal coordinate is determined by employing the method of the charge division the spatial resolution for registering the minimum ionizing particles is considerably lower than for registering gammas from a ^{55}Fe source. The anode wire with smaller specific resistance is used in an approach based on DTM which influences a range of height of pulse less and improves the signal relation in a background. We have compared an accuracy which can be achieved in the framework of DTM method for the registration of gammas from a ^{55}Fe source

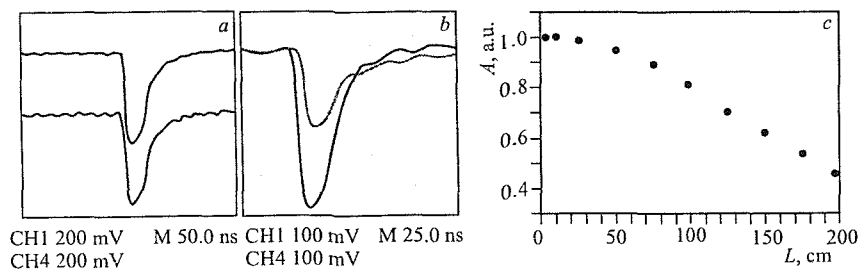

Fig. 2. *a*) Signal registered at the ends of the anode when a collimated ^{55}Fe source is located at the middle of the straw. *b*) Typical signals registered by an amplifier when a collimated ^{55}Fe source is located near the ends of a straw. *c*) Signal attenuation as a function of the distance from the straw end. The gas mixture pressure is 1 bar; gas gain is $\sim 7 \cdot 10^4$

with that for registration of electrons from ^{106}Ru source by varying the matching impedance between the straw and amplifiers. The measurements included an option without series resistors R_s (Fig. 1) at the input of the amplifier with the impedance of 120Ω as well as the options with resistors of 180 and 240Ω connected in series to the input. As a result, the leading edge of the signals measured at the pulse height 0.1–0.9 is changed from 6 to 11 and 16 ns, respectively. Incomplete matching in the first two cases resulted in a considerable change in the pulse shape caused by superposition of the reflected opposite-phase signal thus hampering optimization of T_t and T_b levels along the straw. The pulse shapes registered for different matching options are displayed in Fig. 3.

The highest accuracy of the method under study has been achieved by using the matching series resistor of 300Ω . It is shown in Fig. 4, *a* as a function of the distance of the collimated ^{55}Fe source from the middle of the straw. In the

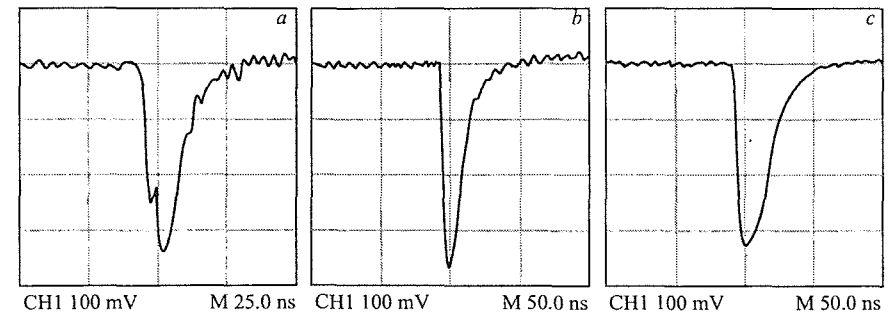

Fig. 3. *a*) Typical signals obtained in the absence of a 180Ω series resistors R_s ; *b*) for an option with $R_s = 180 \Omega$; *c*) for an option with $R_s = 240 \Omega$. The gas mixture pressure is 1 bar; gas gain is $\sim 7 \cdot 10^4$

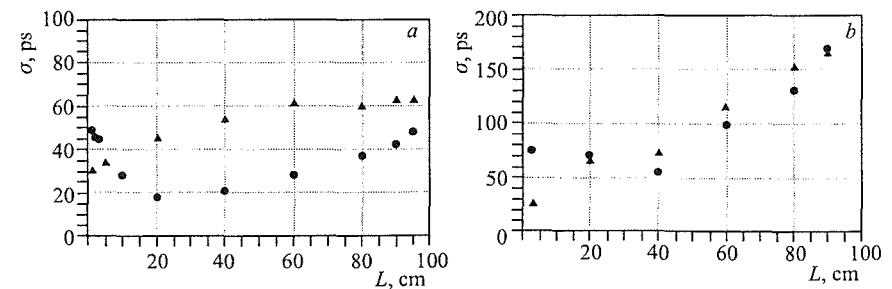

Fig. 4. Accuracy (r.m.s.) of the determination of the longitudinal coordinate along a 2 m long straw for incomplete matching. Filled circles — the gas mixture pressure is 1 bar and gas gain is $\sim 7 \cdot 10^4$ (anode voltage is 1.95 kV). Filled triangle — the gas pressure is 3 bar and the anode voltage is 3.05 kV. The matching impedance for each straw end is 300Ω . *a*) ^{55}Fe source; *b*) ^{106}Ru source

measurements, the T_t and T_b levels have been optimized individually for each position of the source. Note, that 1 cm distance corresponds to the difference in the time delay $\delta t = 69.8$ ps. As follows from the plot, the accuracy in registering gamma quanta at the pressure of 1 bar and a gas amplification of $\sim 7 \cdot 10^4$ can be as high as 20–48 ps whereas at the pressure of 3 bar in the high-current mode the resolution is of the order of 30–63 ps. The deterioration of the resolution is likely caused by a strong change of the slope of the leading edge for the saturated pulses. Similar dependences obtained with the ^{106}Ru source are displayed in Fig. 4, *b*. Apparently, the individual choice of the T_t and T_b levels can provide the accuracy in the measurements of the longitudinal coordinate in the range of 20–170 ps.

The main results have been obtained with the matching impedance of 360Ω obtained by connecting series resistors of 240Ω .

As is apparent from Fig. 5, the spatial longitudinal resolution (r.m.s.) for registering gammas of 5.9 keV at a gas amplification of $\sim 7 \cdot 10^4$ for 2 m straws depending on the T_t and T_b levels is 20–60 ps which corresponds to 3–9 mm. In this case the values of T_t and T_b which are 0.2 and 0.7, respectively, provide similar accuracy for this interval along full length of a straw.

Similar resolution has been obtained in registering high-energy electrons from ^{106}Ru source at the pressure of 1 bar and a gas amplification of $7 \cdot 10^4$ (Fig. 6, *a*) and at the pressure of 3 bar in the high-current detection mode (Fig. 6, *b*) for the same values of T_t and T_b which are 0.2 and 0.7, respectively. A feasibility of choosing a common interval over the full straw length for the levels used in the

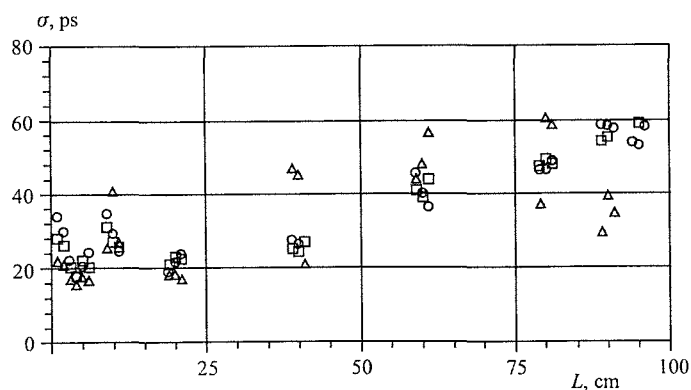

Fig. 5. Spatial resolution along one half of a straw for registering gammas from ^{55}Fe gamma-ray source. The gas mixture pressure is 1 bar and the gas gain is $\sim 7 \cdot 10^4$. T_t and T_b levels are 0.2 and 0.7 (open circles), 0.05 and 0.8 (open triangles), and 0.1 and 0.6 (open squares), respectively

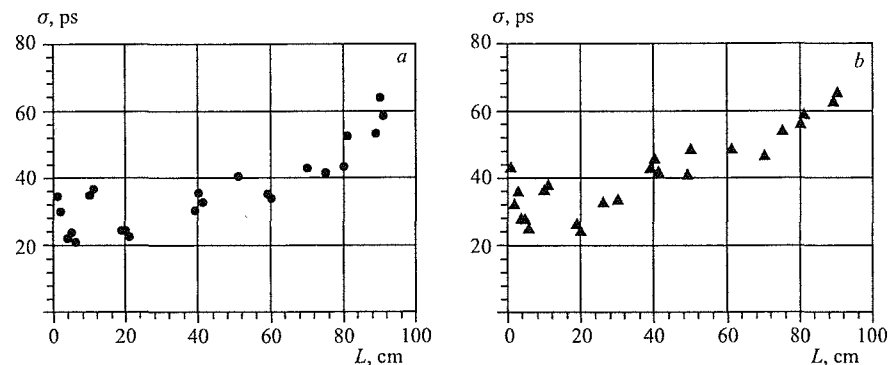

Fig. 6. Spatial resolution along one half of a straw for registering electrons from ^{106}Ru source. *a*) The gas mixture pressure is 1 bar and the gas gain is $\sim 7 \cdot 10^4$. *b*) The gas mixture pressure is 3 bar, the anode voltage is 3.05 kV

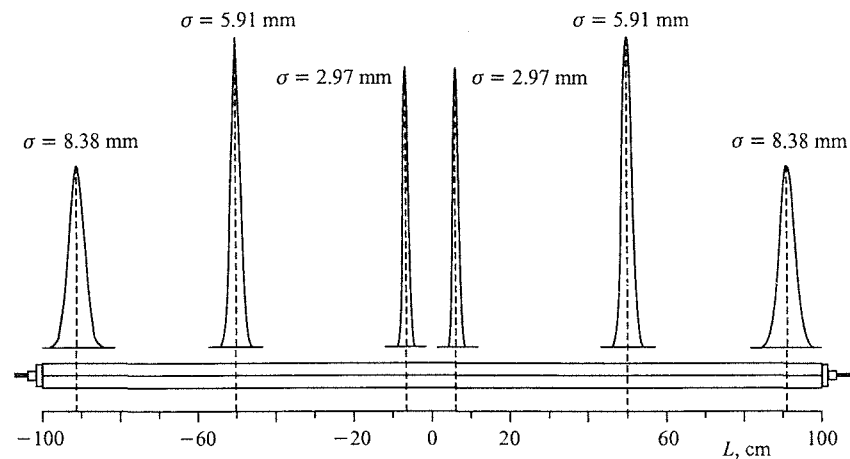

Fig. 7. Results of the measurements of the spatial accuracy as function of the source position with respect to the middle of 2 m long straw indicated as zero. The straws were irradiated by electrons from ^{106}Ru source, the gas mixture pressure is 1 bar and the gas gain is $\sim 7 \cdot 10^4$

linear approximation of the leading edge indicates a possibility of employing the DTM method in multichannel detectors.

The results of the measurements of the longitudinal coordinate for a 2 m straw obtained both by detecting gammas and minimum ionizing particles in different operation modes of straw tubes are displayed in Fig. 7.

CONCLUSIONS

The measurements performed in the present studies of thin-walled straw tubes have demonstrated that in addition to the precision measurements of transverse to the anode coordinates fast current amplifiers can be employed for the measurements of the longitudinal coordinates with reasonable accuracy by using the direct timing method. If the accuracy of the transverse coordinates remains as high as 170 mkm, then the precision of a few mm obtained in determination of the longitudinal coordinate of MIP allows one to consider such detectors as high precision large area detectors. Similar accuracy achieved in different straw operation modes such as registering of gammas of fixed energy and charged particles in the proportional and high-current modes is indicative of good prospects of implementing DTM method. The presented technique allows one to obtain high spatial resolution in the direction longitudinal to the anode and, probably, can increase accuracy in the transverse direction as compared to the conventional method.

REFERENCES

1. *Bychkov V. N. et al. // Nucl. Instr. Meth. A. 1993. V. 325. P. 158.*
2. *Majewski S. et al. // Nucl. Instr. Meth. A. 1994. V. 348 P. 307.*
3. *Golutvin I. A. et al. // Nucl. Instr. Meth. A. 1993. V. 333. P. 536.*
4. *Popp J. L. // Nucl. Instr. Meth. A. 2001. V. 472. P. 354.*
5. *Bino C. et al. // Nucl. Instr. Meth. A. 1988. V. 271. P. 417;*
Sokolov A. et al. // Nucl. Instr. Meth. A. 2007 V. 574. P. 50.
6. *Boie R. A. et al. // IEEE Trans. Nucl. Sci. 1988. V. NS-28. P. 471.*
7. *Bychkov V. N. et al. // Particles and Nuclei, Letters. 2002. No. 2 (111). P. 64.*
8. *Davkov V. I. et al. // Nucl. Instr. Meth. A. 2011. V. 634. P. 5.*
9. *Davkov K. I. et al. // Nucl. Instr. Meth. A. 2008. V. 584. P. 285.*
10. Paul Scherrer Institut. DRS4 Evaluation Board User's Manual.
<http://drs.web.psi.ch/datasheets>

Received on July 10, 2012.

Маканькин А. М. и др.

E1-2012-78

Метод прямых временных измерений для двумерных прецизионных координатных детекторов на основе тонкостенных дрейфовых трубок

Представлены результаты измерения продольного пространственного разрешения строу длиной 2 м методом прямых временных измерений (DTM). Показана возможность получения координатной точности (σ) лучше 9 мм по всей длине строу. Величина пространственного разрешения слабо изменяется как при регистрации гамма-квантов источника ^{55}Fe , так и при регистрации заряженных частиц с минимальными ионизационными потерями от источника ^{106}Ru . Использование одного типа FEE для получения данных как по измерениям времени дрейфа электронов ионизации, так и по распространению сигнала вдоль анодной проволоки позволит создать двумерный детектор для прецизионных координатных измерений.

Работа выполнена в Лаборатории физики высоких энергий им. В. И. Векслера и А. М. Балдина ОИЯИ.

Сообщение Объединенного института ядерных исследований. Дубна, 2012

Makankin A. M. et al.

E1-2012-78

A Direct Timing Method for the Two-Dimensional Precision Coordinate Detectors Based on Thin-Walled Drift Tubes

The results of a study of the longitudinal spatial resolution of 2 m long straw tubes by means of the direct timing method (DTM) are presented. The feasibility of achieving a coordinate resolution (r.m.s.) better than 9 mm over full length of the straw is demonstrated. The spatial resolution insignificantly changes when measured by detecting gammas from a ^{55}Fe gamma-ray source or minimum ionizing particles from a ^{106}Ru source. The use of the same type of FEE for data taking both for measuring the drift time of ionization electrons and propagation of a signal along the anode wire allows one to construct a two-dimensional detector for precision coordinate measurements.

The investigation has been performed at the Veksler and Baldin Laboratory of High Energy Physics, JINR.

Communication of the Joint Institute for Nuclear Research. Dubna, 2012

Корректор *Т. Е. Попеко*

Подписано в печать 16.08.2012.

Формат 60 × 90/16. Бумага офсетная. Печать офсетная.

Усл. печ. л. 0,68. Уч.-изд. л. 0,92. Тираж 285 экз. Заказ № 57735.

Издательский отдел Объединенного института ядерных исследований
141980, г. Дубна, Московская обл., ул. Жолио-Кюри, 6.

E-mail: publish@jinr.ru

www.jinr.ru/publish/