

SUPERCONDUCTOR CABLES FOR PULSED DIPOLE MAGNETS

G.E. GALLAGHER-DAGGITT

ABSTRACT

Superconductor cables employed in the construction of the RHEL series of superconducting dipole magnets ACIII, IV and V have undergone a process

of evolution stimulated by the development of three component filamentary composite conductors having improved properties and an increasing number of filaments.

The object of this paper is to trace this evolution which has culminated in the development of the current "Flat 15" type cable which is to be used in the construction of the next generation of pulsed superconducting dipole magnets.

The manufacturing process employed in the construction of these cables is also to be briefly described.

Rutherford High Energy Laboratory
Chilton
Didcot
Berks.

February 1973

MAST

DISTRIBUTION OF THIS DOCUMENT IS

1. INTRODUCTION

Filamentary superconducting composite conductors developed in a collaboration between RHEL and IRI Limited have typical current carrying capabilities in the range 50-200A at 3-6 Tesla and in order to achieve the higher currents, 3000-5000A at 5 Tesla, required in the construction of the RHEL series of pulsed dipole magnets for a superconducting synchrotron, it has been necessary to assemble the composite conductors in the form of multistrand cables.

2.1 General Considerations

The geometry of assembly of strands into a cable is arrived at from consideration of the following:-

- a) Electromagnetic Criteria ^(1,2,3) - operating current, magnetic field, magnetisation losses, stability and current sharing between the strands. The current sharing criteria dictates the need for transposition* of strands in the cable.
- b) Magnet Construction Criteria - heat transfer, positional accuracy of the turns in the winding, ease of winding, and support against the forces obtaining in operation.
- c) Cable Construction Criteria - that the probability of strand breakage during manufacture be negligible; that the density of superconductor strand in the volume of the cable be high for reasons of economy, good heat transfer and positional stability and finally that any degradation of the current carrying capacity due to deformation of the strand cross-section be acceptably small.

2. SURVEY OF CABLES FOR PULSED DIPOLE MAGNETS

pulsed dipole magnets for a superconducting synchrotron, it has been necessary to assemble the composite conductors in the form of multistrand cables.

The geometry of assembly of strands into a cable is arrived at from consideration of the following:-

- a) Electromagnetic Criteria^(1,2,3) - operating current, magnetic field, magnetisation losses, stability and current sharing between the strands. The current sharing criteria dictates the need for transposition* of strands in the cable.
- b) Magnet Construction Criteria - heat transfer, positional accuracy of the turns in the winding, ease of winding, and support against the forces obtaining in operation.
- c) Cable Construction Criteria - that the probability of strand breakage during manufacture be negligible; that the density of superconductor strand in the volume of the cable be high for reasons of economy, good heat transfer and positional stability and finally that any degradation of the current carrying capacity due to deformation of the strand cross-section be acceptably small.

2. SURVEY OF CABLES FOR PULSED DIPOLE MAGNETS

2.1 General Considerations

A filament diameter of 5 μ is necessary in order to keep the hysteresis loss

* transposition - cable geometry which enables all strands to have identical symmetry with respect to the axis of the cable.

of a pulsed dipole magnet within acceptable limits, and since 30 mA is the current it will carry at 5 Tesla, a large number, (10^5) such filaments must be connected in parallel in order to produce a cable suitable for 3000A 5 Tesla operation.

The geometry of the cable designed to carry this current will depend on the number of strands which need to be connected in parallel and this in turn depends on the number of filaments accommodated within each strand.

The number of filaments accommodated in a superconducting strand has increased steadily during the past four years and successive superconducting dipole magnets, ACIII, ACIV and ACV utilise strand having 1045, 2035 and 891 filaments respectively. These changes in conductor design have stimulated the development of special cable geometries requiring unconventional manufacturing techniques.

2.2 ACIII Superconductor Cable

The general form of this 90 x 0.4 mm diameter strand cable can be seen in the picture Figure 1b, and the construction and operating parameters are listed in Table 2.

A six bobbin planetary strander, Figure 2, was employed to construct the cable that consists of a basic unit of three strands which were simultaneously drawn and twisted to form a triplet having the form shown in Figure 1a, (3) stage. Five triplets were then twisted together over a 0.5 mm diameter copper filler strand in a second operation, (5x3) stage. Finally six elements having the (5x3) stage configuration were twisted over a seven strand copper filler cable then compacted in the (6x5x3) stage of the process to give the final square section shown in Figure 1b. An oxide coating on each

The geometry of the cable designed to carry this current will depend on the number of strands which need to be connected in parallel and this in turn depends on the number of filaments accommodated within each strand.

The number of filaments accommodated in a superconducting strand has increased steadily during the past four years and successive superconducting dipole magnets, ACIII, ACIV and ACV utilise strand having 1045, 2035 and 891 filaments respectively. These changes in conductor design have stimulated the development of special cable geometries requiring unconventional manufacturing techniques.

- 2 -

2.2 ACIII Superconductor Cable

The general form of this 90 x 0.4 mm diameter strand cable can be seen in the picture. Figure 1b, and the construction and operating parameters are listed in Table 2.

A six bobbin planetary strander, Figure 2, was employed to construct the cable that consists of a basic unit of three strands which were simultaneously drawn and twisted to form a triplet having the form shown in Figure 1a, (3) stage. Five triplets were then twisted together over a 0.5 mm diameter copper filler strand in a second operation, (5x3) stage. Finally six elements having the (5x3) stage configuration were twisted over a seven strand copper filler cable then compacted in the (6x5x3) stage of the process to give the final square section shown in Figure 1b. An oxide coating on each strand provided adequate interstrand resistance and terylene braid was woven over the cable in order to provide interturn insulation in the magnet

2.3 ACIV Cable

Comprises 25 x 0.85 mm diameter superconductor wire strands and has the

form shown in the picture, Figure 3b. The significant constructional and operational parameters are listed in Tables 1 and 2 while the steps in the construction can be seen from the cross-sections shown in Figure 3a.

A six bobbin planetary strander, Figure 2, was again used and wire drawing techniques were employed in the first stage of construction to obtain the compact group of five shaped strands shown. Five such elements were combined in the second stage and compacted to give the rectangular section

~~cable. An oxide layer again provided the individual strand insulation and~~
The distortion method⁽⁴⁾ provides the conditions whereby a layer of con-
a terylene braid the overall cable insulation.

~~Distorted cylindrical helices can be generated without the support of~~

2.4 ACV Cable

The cable which has been developed for use in the projected ACV pulsed dipole magnet consists of 15 x 1.06 mm diameter strands and will have the form shown in Figure 4b. The techniques employed in its construction are new to the technology of cable manufacture and will be described in the next section.

The finished section is that shown in Figure 4a; it is a truncated diamond or "lozenge". During the manufacturing process the 15 strands are temporarily supported on the periphery of a circle as shown in Figure 4a, then they are supported on the periphery of an ellipse before being compacted to the final shape shown.

The interstrand insulation is to be an aromatic polyimide polymer enamel film and the overall cable insulation a terylene or glass braid.

3. ACV CABLE ("FLAT 15") - METHOD OF MANUFACTURE

3.1 The Distortion Method

combined in the second stage and compacted to give the rectangular section cable. An oxide layer again provided the individual strand insulation and a terylene braid the overall cable insulation.

2.4 ACV Cable

The cable which has been developed for use in the projected ACV pulsed dipole magnet consists of 15 x 1.06 mm diameter strands and will have the form shown in Figure 4b. The techniques employed in its construction are new to the technology of cable manufacture and will be described in the next section.

The finished section is that shown in Figure 4a; it is a truncated diamond or "lozenge". During the manufacturing process the 15 strands are temporarily supported on the periphery of a circle as shown in Figure 4a, then they are supported on the periphery of an ellipse before being compacted to the final shape shown.

The interstrand insulation is to be an aromatic polyimide polymer enamel film and the overall cable insulation a terylene or glass braid.

3. ACV CABLE ("FLAT 15") - METHOD OF MANUFACTURE

3.1 The Distortion Method

The distortion method⁽⁴⁾ provides the conditions whereby a layer of contiguous circular cylindrical helices can be generated without the support of other internal layers. The support is provided instead by a "core pin", Figure 5, which is rigidly supported on the axis of a stranding die having

circular aperture. At the exit of the stranding die the circular cylindrical helixes pass over the "elliptical transition" attached to the end of the "core pin" and are deformed to become elliptical cylindrical helixes before they enter the aperture of the turkshead roller die where final deformation to the required section occurs.

After the final deformation, which can give 95% metal density in the cross-section, the cable becomes self supporting by virtue of its shape and the up to the exit where the intermediate state commences and reads gently hardening which occurs during compaction.

into the final state of deformation by the turkshead roller die. The sequence of the stranding operation is shown in simplified form in Figure 6. The finished section is that shown in Figure 4a. The 15 strands are 1, 2 and 3 of a circular frame rotating with constant angular velocity, ω radians per second, are formed into circular cylindrical helixes at the stranding die while being temporarily supported on the "core pin".

Conditions for the generation of spiral curves which are circular helixes are provided by the frame which rotates at constant angular velocity and the

constant linear velocity at which the junction of the strands 1, 2 and 3 is hauled in the direction of the strands shown. Five such elements were

In machines of the types depicted in Figures 2 and 9 the source of supply of each strand is supported in a cradle which "floats" on the rotating frame. This arrangement ensures that each strand is not twisted about its own axis while being formed into a helix and prevents torsional stress in the resultant cable.

Cross-sections of the cable during processing are shown in Figure 4a. The initial state shown occurs at the entrance to the stranding die and continu

section, the cable becomes self supporting by virtue of its shape and the hardening which occurs during compaction.

The sequence of the stranding operation is shown in simplified form in Figure 6. Strands 1, 2 and 3 which are constrained to pass through points 1, 2 and 3 of a circular frame rotating with constant angular velocity, w radians per second, are formed into circular cylindrical helixes at the stranding die while being temporarily supported on the "core pin".

Conditions for the generation of spiral curves which are circular helixes are provided by the frame which rotates at constant angular velocity and the constant linear velocity at which the junction of the strands 1, 2 and 3 is hauled in the direction z .

In machines of the types depicted in Figures 2 and 9 the source of supply of each strand is supported in a cradle which "floats" on the rotating frame. This arrangement ensures that each strand is not twisted about its own axis while being formed into a helix and prevents torsional stress in the resultant cable.

Cross-sections of the cable during processing are shown in Figure 4a. The initial state shown occurs at the entrance to the stranding die and continues up to the exit where the intermediate state commences and leads gently into the final state of deformation by the turkshead roller die. The gradual transition from a circular section through to an elliptical section is accomplished by the "core pin" transition shown in Figure 7. It ensures that the strand formation is supported and adjusted to the correct aspect they enter the aperture of the turkshead roller die.

so the required section occurs.

ratio before final deformation occurs in the turkshead roller die. The interlocking formation of this die which enables adjustment of the aperture is shown in Figure 8. A lozenge section is obtained by suitable shaping of the vertical rollers as shown in Figure 8.

3.2 The Stranding Machine

The operation described is executed on a stranding machine of the type shown in a simple form in Figure 9. The core pin is supported upon a shaft which is located on the axis of the rotating frame by roller and thrust bearings which also has the virtue of indicating the likely effect of changing a and stabilised against rotation by a stabilising weight as shown.

The turkshead roller die is rigidly attached to a firm upright frame (not shown) and the stranding die is attached to the face of the roller die block

3.3 Special Tools

A rectangular or "lozenge" section, coreless, multistrand cable has associated with it four interdependent design parameters:-

Number of strands

Strand diameter

Twist pitch

Density of metal in the cross-section

The relationship between these parameters is taken into consideration in designing the special set of tools which are required in order to produce a cable of this type.

A stranding die, core pin, core pin transition and an alignment jig for setting up the turkshead roller die are uniquely associated with a cable having a particular combination of the parameters listed.

The design process is facilitated by a tool design computation programme,

in a simple form in Figure 9. The core pin is supported upon a shaft which is located on the axis of the rotating frame by roller and thrust bearings and stabilised against rotation by a stabilising weight as shown.

The turkshead roller die is rigidly attached to a firm upright frame (not shown) and the stranding die is attached to the face of the roller die block

3.3 Special Tools

A rectangular or "lozenge" section, coreless, multistrand cable has associated with it four interdependent design parameters:-

Number of strands

Strand diameter

Twist pitch

Density of metal in the cross-section

3.2 The Stranding Machine

The relationship between these parameters is taken into consideration in designing the special set of tools which are required in order to produce a cable of this type. The operation described is executed on a stranding machine of the type shown in a simple form in Figure 9. The core pin is supported upon a shaft which is located on the axis of the rotating frame by roller and thrust bearings and stabilised against rotation by a stabilising weight as shown.

A stranding die, core pin, core pin transition and an alignment jig for setting up the turkshead roller die are uniquely associated with a cable having a particular combination of the parameters listed. The turkshead roller die is rigidly attached to a firm upright frame (not shown) and the stranding die is attached to the face of the roller die block

The design process is facilitated by a tool design computation programme,

3.3 Special Tools

which also has the virtue of indicating the likely effect of changing a parameter during manufacture. A rectangular or "lozenge" section, coreless, multistrand cable has associated with it four interdependent design parameters:-

4. PERFORMANCE TESTS AND MEASUREMENTS

Superconductor cables manufactured at RHEL are subject to the following tests and measurements after manufacture:-

- a) Strand continuity tests conducted at 4.2°K
- b) Short sample tests combined with resistance transition measurements.

Continuity tests locate any gross damage that may have occurred during cabling while the resistive transition measurements provide a basis for

comparing the properties of the cabled and the uncabled strand.

When making such comparisons it is to be noted that there is some 20% Typical results of such measurements (7) carried out on ACIII, ACIV and ACV

cables are shown in Figures 10, 11 and 12 respectively. Many such

measurements are required in order to optimise the heat treatment cycle which is carried out after the cabling process.

The time and temperature of this heat treatment is uniquely determined for each new cable geometry and each new type of superconductor used in its construction.

Heat treatment optimisation was not carried out on the ACIII cable. The main concern was to minimise strand damage during the successive stages of construction, therefore heat treatment cycles were interposed between stag

This may partially account for the 20% difference in the critical current density of cabled and uncabled strand when compared at 4 Tesla and $10^{-12} \Omega \text{cm}$ resistivity.

A similar difference occurs for ACIV cable while for ACV the difference is only 10-11% despite the fact that the tests were carried out on a batch of research material and that no attempts have as yet been made to optimise t

heat treatment cycle

cabling while the resistive transition measurements provide a basis for comparing the properties of the cabled and the uncabled strand.

Typical results of such measurements⁽⁷⁾ carried out on ACIII, ACIV and ACV cables are shown in Figures 10, 11 and 12 respectively. Many such measurements are required in order to optimise the heat treatment cycle which is carried out after the cabling process.

The time and temperature of this heat treatment is uniquely determined for each new cable geometry and each new type of superconductor used in its

construction.

Heat treatment optimisation was not carried out on the ACIII cable. The

main concern was to minimise strand damage during the successive stages of construction, therefore heat treatment cycles were interposed between stages

This may partially account for the 20% difference in the critical current density of cabled and uncabled strand when compared at 4 Tesla and $10^{-12} \Omega \text{cm}$ resistivity.

A similar difference occurs for ACIV cable while for ACV the difference is only 10-11% despite the fact that the tests were carried out on a batch of research material and that no attempts have as yet been made to optimise the heat treatment cycle.

When making such comparisons it is to be noted that there is some 20% difference between the guaranteed and typical short sample properties of the superconducting strand in manufacturers quotations.

5. CONCLUSION

Superconducting cable technology has advanced rapidly over the period of the past three years. It has been stimulated by the rapid advances in superconductor research and manufacture while at the same time being subject to the increasingly stringent requirements of successive pulsed dipole magnets.

Advances in superconductors have permitted fewer strands to be used in order to achieve a given performance as measured in terms of the short sample manufacture cables having as few as 5 strands and as many as 25 strands. ~~curve, Figure 13. The trend towards fewer strands has culminated in the development of the ACV (Flat 15) type cable shown in Figures 4a and 4b.~~

This single layer, coreless geometry meets the electromagnetic need for strand transposition while at the same time being capable of withstanding a high degree of compaction during manufacture. A matrix density of 95% has been achieved in a 15 strand superconductor cable without serious deterioration in performance. Resistive transition measurements indicate that the short sample properties remain constant for cables having matrix densities of 85%, 90% and 95%. High matrix density in the cable is important from economic considerations related to the construction of superconducting synchrotrons⁽⁸⁾. It is also important in order to meet the stringent field uniformity requirements in synchrotron magnets and of continuity tests locate any gross damage that may have occurred ensuring good heat transfer from within the cable. Recent manufacturing trials have indicated that it is possible to manufacture to a dimensional accuracy of ± 0.01 mm over a 200 metre length of cable and that this tolerance is maintained provided that the cable is annealed after manufacture to relieve built in stresses. The geometry has been successfully applied to

Advances in superconductors have permitted fewer strands to be used in order to achieve a given performance as measured in terms of the short sample curve, Figure 13. The trend towards fewer strands has culminated in the development of the ACV (Flat 15) type cable shown in Figures 4a and 4b. This single layer, coreless geometry meets the electromagnetic need for strand transposition while at the same time being capable of withstanding a high degree of compaction during manufacture. A matrix density of 95% has been achieved in a 15 strand superconductor cable without serious

deterioration in performance. Resistive transition measurements indicate that the short sample properties remain constant for cables having matrix densities of 85%, 90% and 95%. High matrix density in the cable is

important from economic considerations related to the construction of superconducting synchrotrons⁽⁸⁾. It is also important in order to meet the stringent field uniformity requirements in synchrotron magnets and of ensuring good heat transfer from within the cable. Recent manufacturing trials have indicated that it is possible to manufacture to a dimensional accuracy of ± 0.01 mm over a 200 metre length of cable and that this tolerance is maintained provided that the cable is annealed after manufacture to relieve built in stresses. The geometry has been successfully applied to manufacture cables having as few as 5 strands and as many as 25 strands.

There is good reason to believe that superconductor cables of this type manufactured by the method described will meet the need of future pulsed dipole magnets employing niobium titanium superconductors, until such time as a

solid conductor containing 10^5 filaments is developed and successfully manufactured.

ACKNOWLEDGEMENTS

To M. Wilson for generous advice and participation.

To C. Walters for helpful discussions and unfailing good humour.

To R. Daniels for his continuous help.

To J. Dickson without whose help the machines won't run.

~~At present the work is still at the same stage as in the previous report.~~

High degree of compaction during manufacturing of a matrix conductor.

It is possible to manufacture a 15 strand superconductor cable without serious

disturbances in the matrix. The measurements indicate

that the mechanical properties remain constant for cables having matrix

densities of 85%, 90% and 95%. High matrix density in the cable is

important from economic considerations related to the construction of

superconducting synchrotrons (8). It is also important in order to meet

the stringent field uniformity requirements in synchrotron magnets and of

superconducting transfer from wire to cable. Recent manufacturing

techniques have permitted four strands to be used in order

to meet the performance requirements in terms of the field

uniformity in the magnets.

The work is still at the same stage as in the previous report.

At present the work is still at the same stage as in the previous report.

At present the work is still at the same stage as in the previous report.

LIST OF TABLES

Table 1	Summary of ACIII, IV and V Conductor Parameters
Table 2	Summary of ACIII, IV and V Cable Parameters

LIST OF FIGURES

Fig. 1a	ACIII, 90 Strand-Square Section Cable
Fig. 1b	View of ACIII Cable
Fig. 2	Planetary Stranding Machine
Fig. 3a	ACIV, 25 Strand-Rectangular Section Cable
Fig. 3b	View of ACIV Cable
Fig. 4a	ACV, 15 Strand-Lozenge Section Cable
Fig. 4b	Views of ACV Cable
Fig. 5	Assembly Sequence of Special Tools
Fig. 6	Sequence of Operation ACV Cable
Fig. 7	Core Pin Transition
Fig. 8	Turkshead Roller Die
Fig. 9	Tubular Stranding Machines
Fig. 10	ACIII Strand Performance before and after Cabling
Fig. 11	ACIV Strand Performance before and after Cabling
Fig. 12	ACV Strand Performance before and after Cabling
Fig. 13	Short Sample Properties ACIII, IV and V Cables

Table 1. Summary of ACIII, IV and V Conductor Parameters

<u>Conductor Application</u>	<u>ACIII Dipole</u>	<u>ACIV Dipole</u>	<u>ACV Dipole</u>
Strand Diameter (mm)	0.4	0.85	1.06
Number of filaments	1045	2035	8917
Filament Diameter (μ)	8	11.9	7.6
Strand Twist Pitch (mm)	3.6	4.4	7.5
<u>Composite Constituents</u>			
Niobium Titanium %)	40	40	46.7
Copper %)	43	52	38.3
Cupro-nickel %)	7	8	15.0
Matrix (Ceramic) (g)	1.1-2510	1.50	1.14
Conductor Geometry	α NC55C19C	α NC55C37C	α N241NC37C
Strand Insulation	Oxide	Oxide	Polyimide en.
J_c at 4T $10^{-12}\Omega\text{cm}$ in SC (A/mm ²)	1.9×10^3	1.95×10^3	1.45×10^3

Table 2. Summary of ACIII, IV and V Cable Parameters

<u>Cable Application</u>	<u>ACIII Dipole</u>	<u>ACIV Dipole</u>	<u>ACV Dipole</u>
<u>Magnet Parameters</u>			
Magnet I (A)	5200	5400	
Magnet Field (T)	4.0	4.0	4.5
Magnet rise time (secs)	1.0	1.0	2.0
Cable Dimensions (mm)	5.2 x 5.2	5.83 x 3.85	8.1 x 1.92 (1.)
Cable shape	Square	Rectangular	Lozenge
Number of SC strands	90	25	15
Cable Insulation	Terylene braid	Terylene braid	Terylene bra
Insulation thickness (mm)	0.115	0.115	0.115
<u>Cable Construction</u>			
Twist Pitch (mm)	(3) Stage 12 (5x3) Stage 20 (6x5x3) Stage 63	(5) Stage 16.4 (5x5) Stage 63.8	(15) Stage 11
<u>Cable Density</u>			
Including Fillers %)	60	-	-
Composite Only %)	46	63.2	90
<u>Current Density</u>			
J_c at 4T $10^{-12}\Omega\text{cm}$ in SC (A/mm ²)		1.55×10^3	1.3×10^3

Niobium Titanium %)	40	40	46.7
Copper %)	43	52	38.3
Supro-nickel %)	7	8	15.0
Matrix SC ratio	1.25	1.50	1.14
Conductor Geometry	α NC55C19C	α NC55C37C	α N241NC37C
Strand Insulation	Oxide	Oxide	Polyimide enamel
Jc at 4T $10^{-12} \Omega \text{cm}$ in SC (A/mm ²)	1.9×10^3	1.95×10^3	1.45×10^3

Table 2. Summary of ACIII, IV and V Cable Parameters

Cable Application	ACIII Dipole	ACIV Dipole	ACV Dipole
Magnet Parameters			
Magnet I (A)	5200	5400	4.5
Magnet Field (T)	4.0	4.0	2.0
Magnet rise time (secs)	1.0	1.0	2.0
Cable Dimensions (mm)	5.2 x 5.2	5.83 x 3.85	8.1 x 1.92 (1.74)
Cable shape	Square	Rectangular	Lozenge
Number of SC strands	90	25	15
Cable Insulation	Terylene braid	Terylene braid	Terylene braid
Insulation thickness (mm)	0.115	0.115	0.115
Cable Construction			
Twist Pitch (mm)	(3) Stage 12 (5x3) Stage 20 (6x5x3) Stage 63	(5) Stage 16.4 (5x5) Stage 63.8	(15) Stage 117.5
Cable Density			
Including Fillers %)	60	-	-
Composite Only %)	46	63.2	90
Current Density			
Jc at 4T $10^{-12} \Omega \text{cm}$ in SC (A/mm ²) (after cabling)	1.5×10^3	1.55×10^3	1.3×10^3

REFERENCES

1. M.N. Wilson. Rutherford Laboratory Report RHEL/M/A26.
2. D.B. Thomas and M.N. Wilson. Rutherford Laboratory Preprint RPP/A93.
3. M.N. Wilson. Rutherford Laboratory Preprint RPP/A89.
4. Patent References - P54480/72.
5. M.N. Wilson et al. Proceedings of Applied Superconductivity Conference Annapolis, 1971.
- ~~6. J.H. Coupland and D.E. Baynham. Magnet Technology Conference, Brookhaven, 1972.~~
7. C. Walters. Private communication
8. P.F. Smith and J.D. Lewin. Nuclear Instruments and Methods 52, 298 (1970)

	<u>AGU Dipole</u>	<u>AGU Dipole</u>
	4.0	4.5
	1.0	1.0
	12	12
	0.1	0.1
	1.7	1.7
	15	15

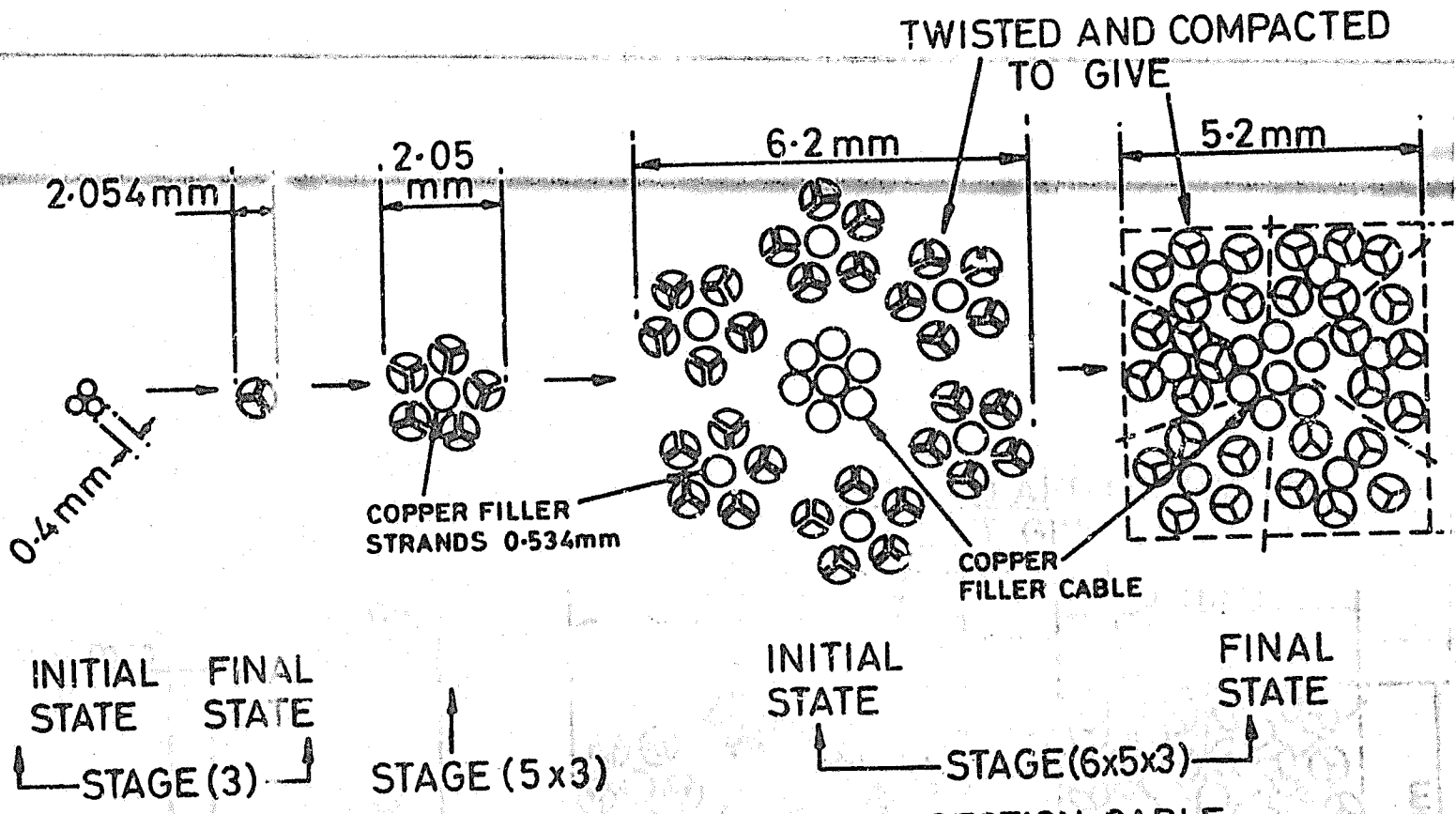

FIG. 1a. AC III, 90 STRAND - SQUARE SECTION CABLE

5.2mm

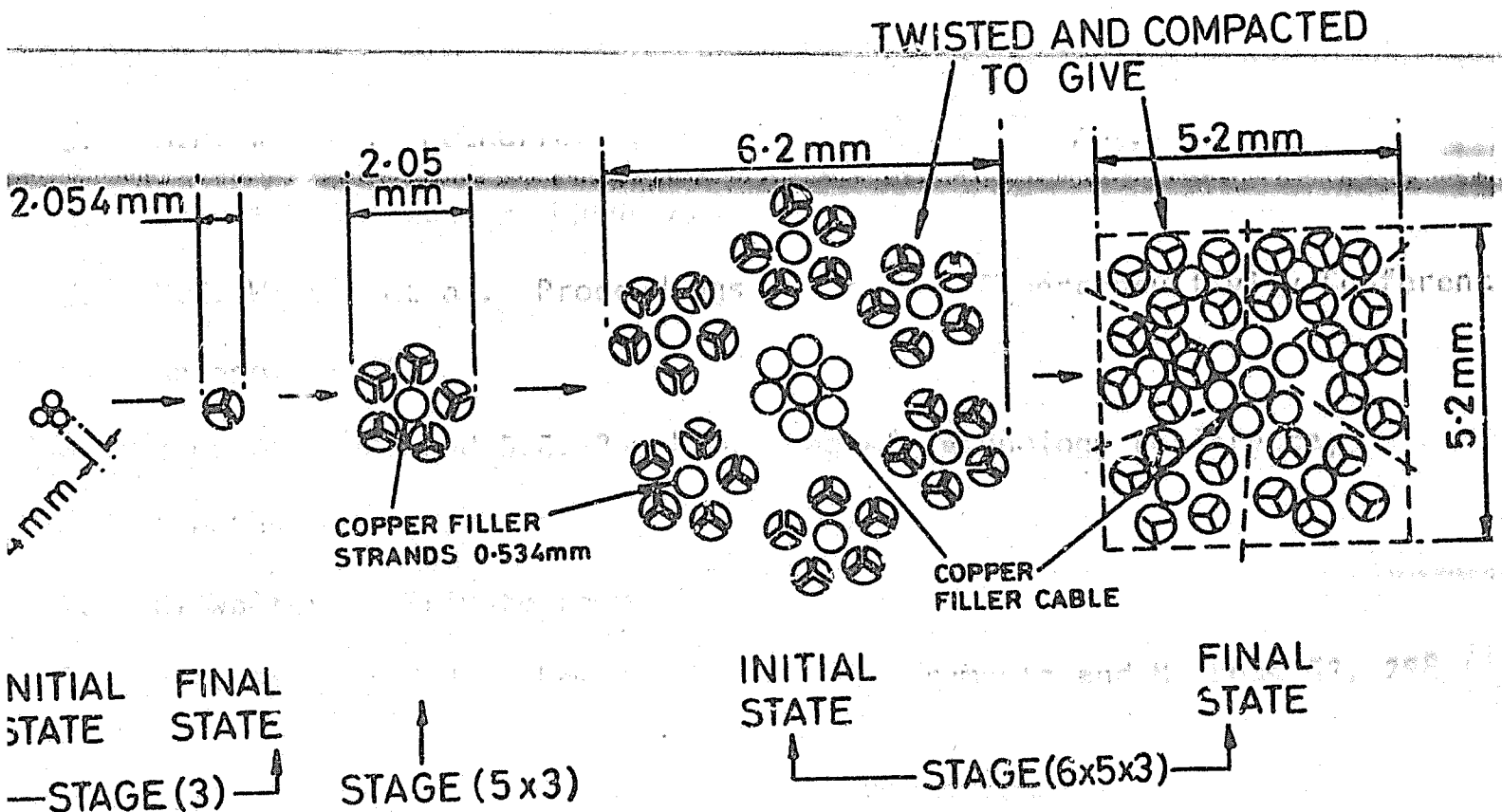

FIG. 1a. AC III, 90 STRAND - SQUARE SECTION CABLE

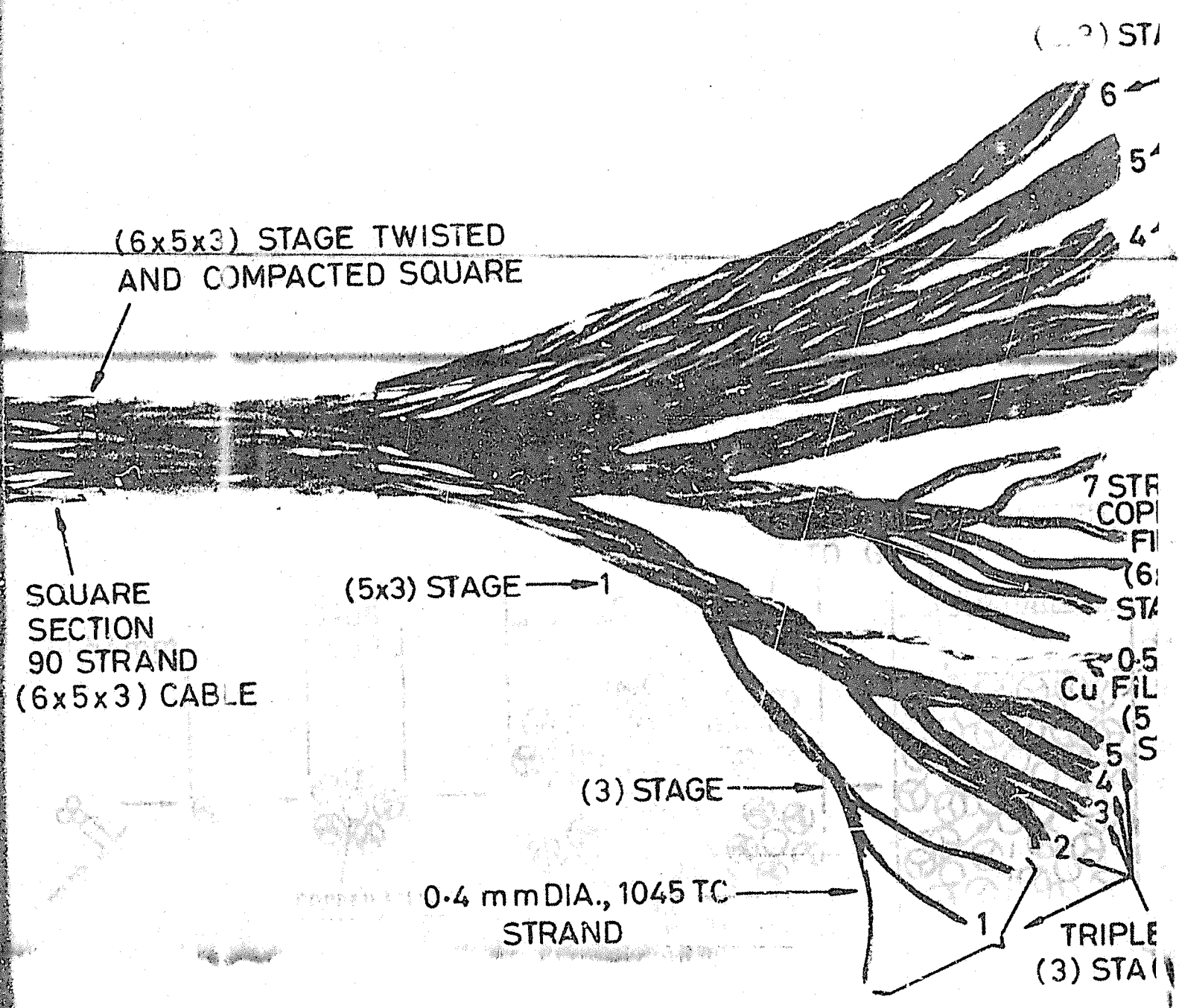

Fig. 1b View of ACIII cable

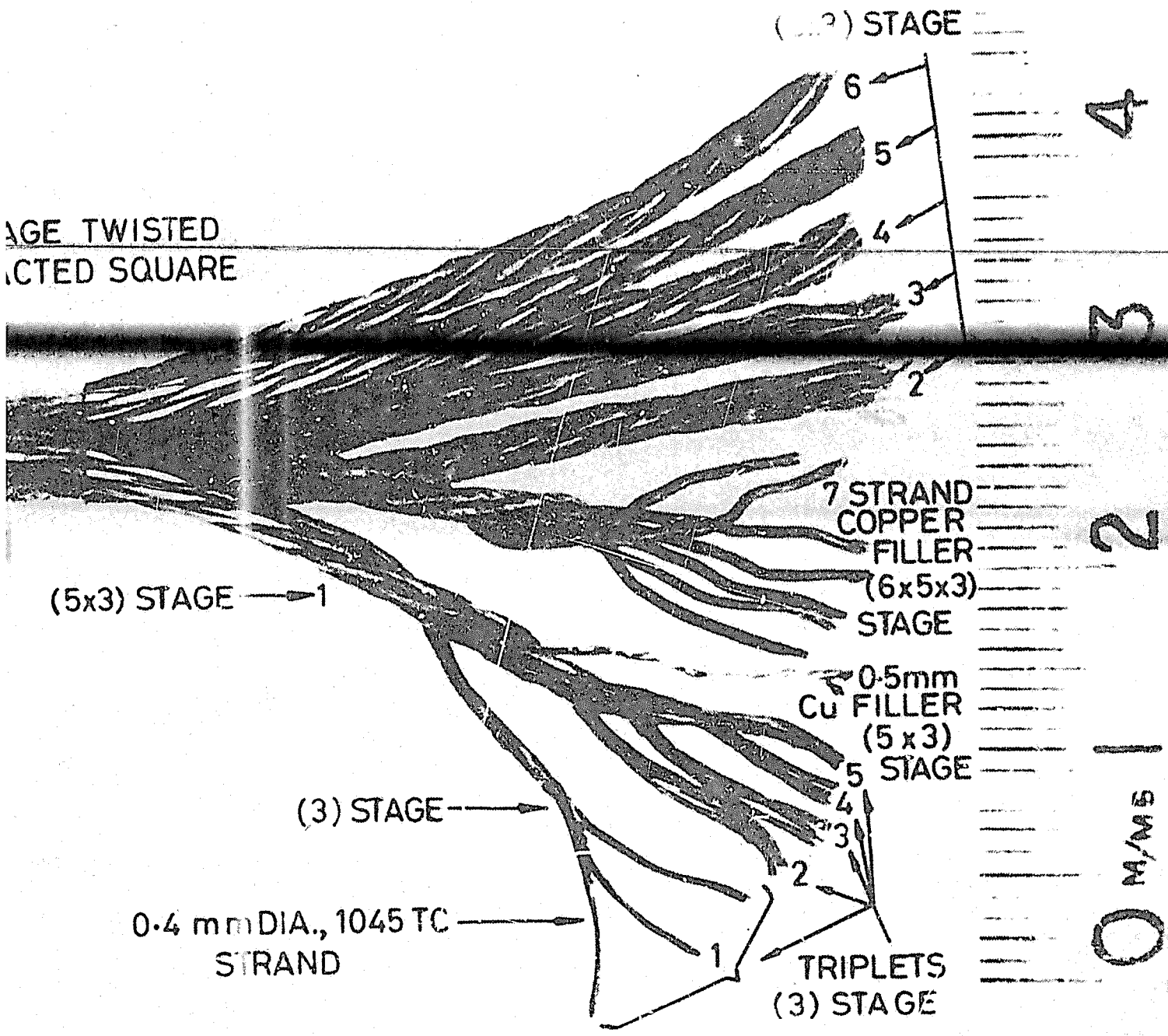

Fig. 1b View of ACIII cable

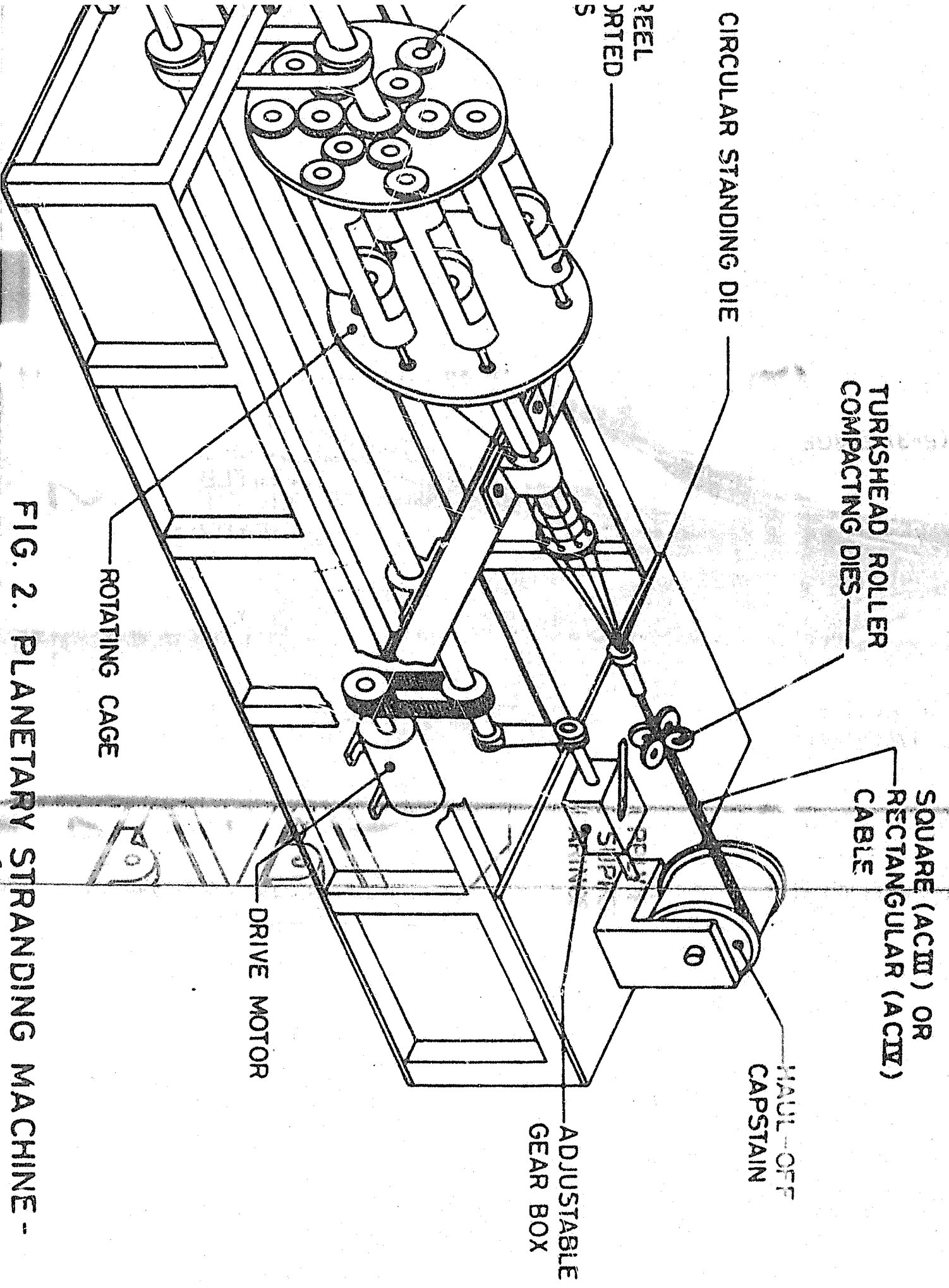

FIG. 2. PLANETARY STRANDING MACHINE -
 SIMPLIFIED DIAGRAM

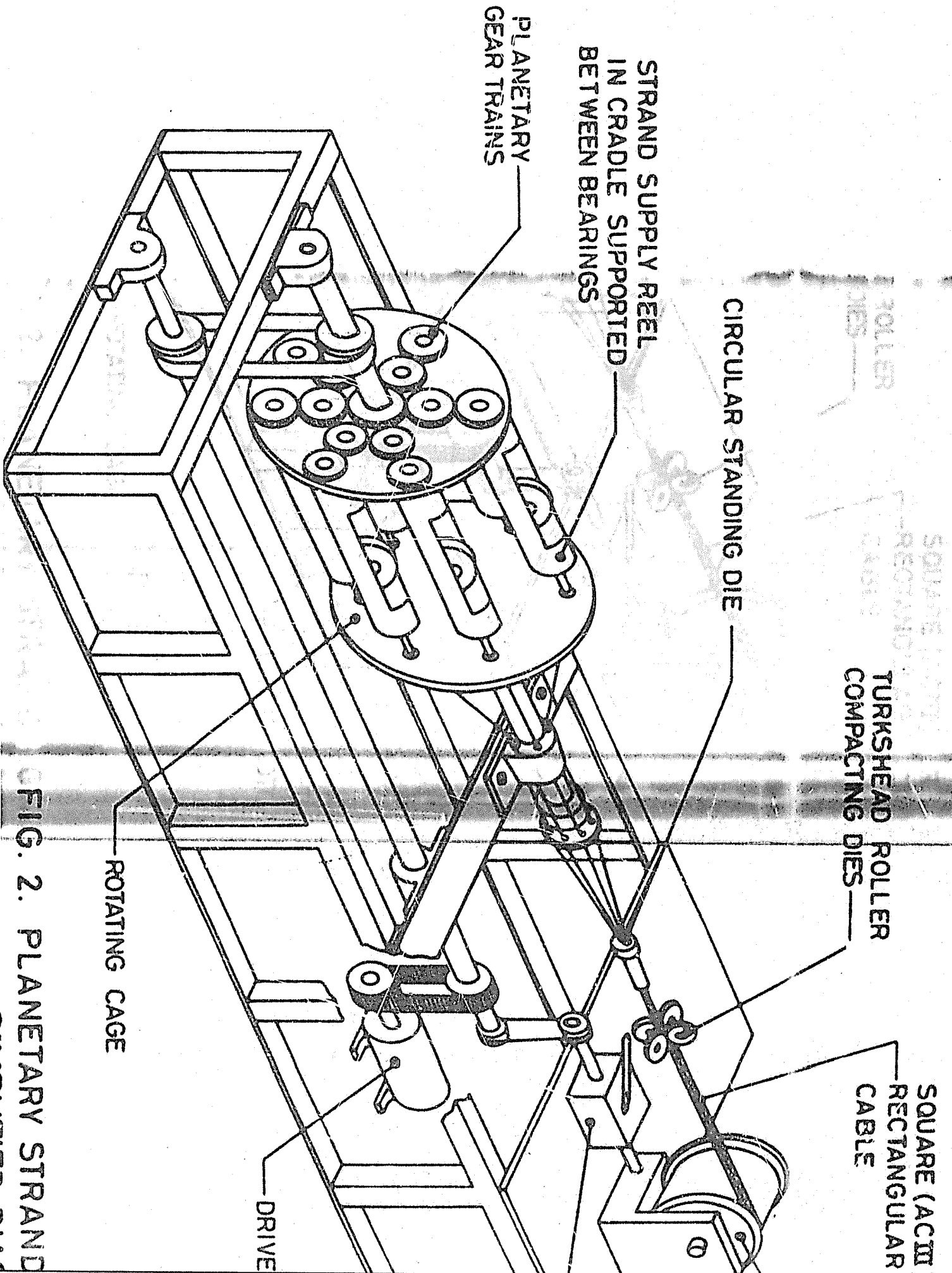

FIG. 2. PLANETARY STRAND

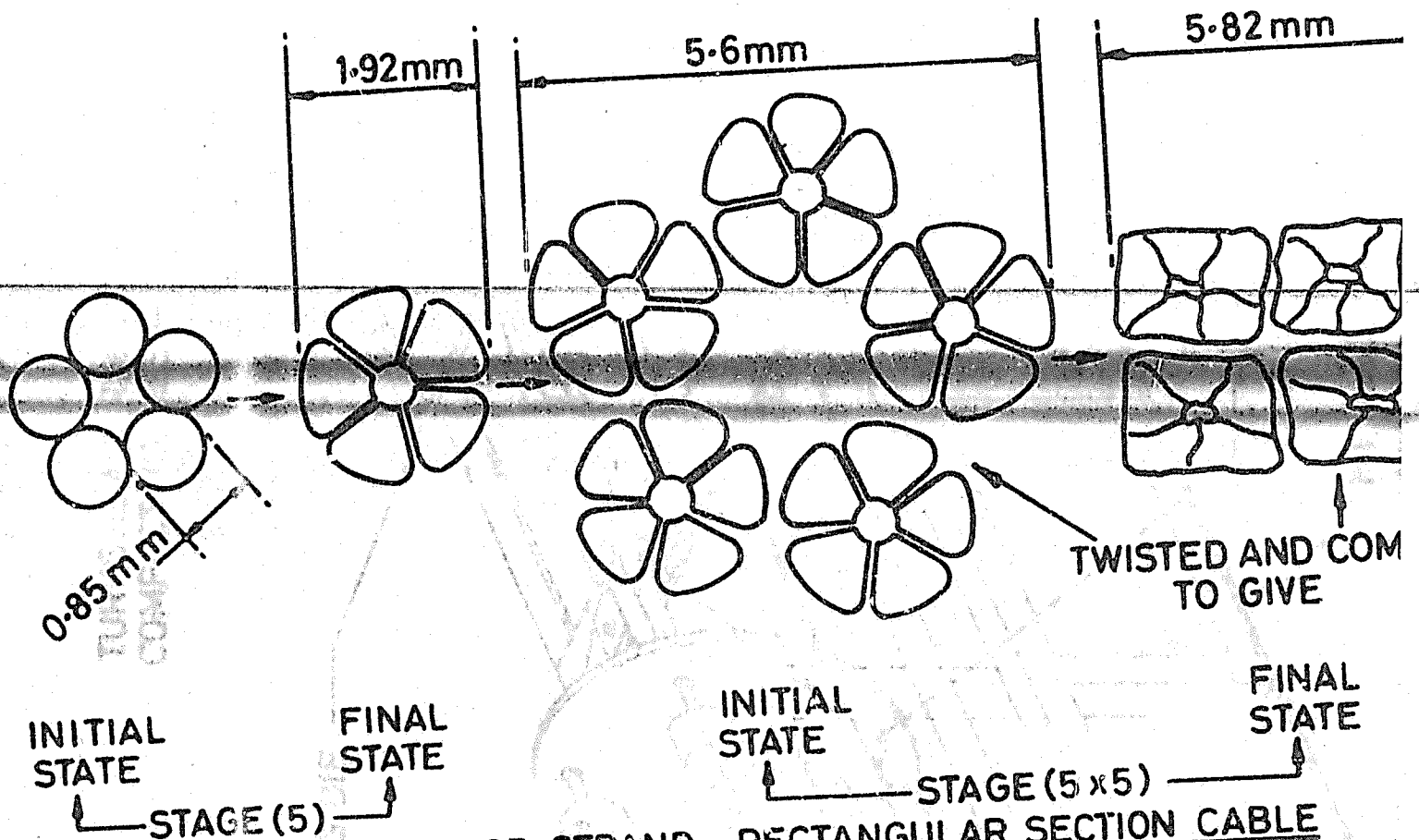
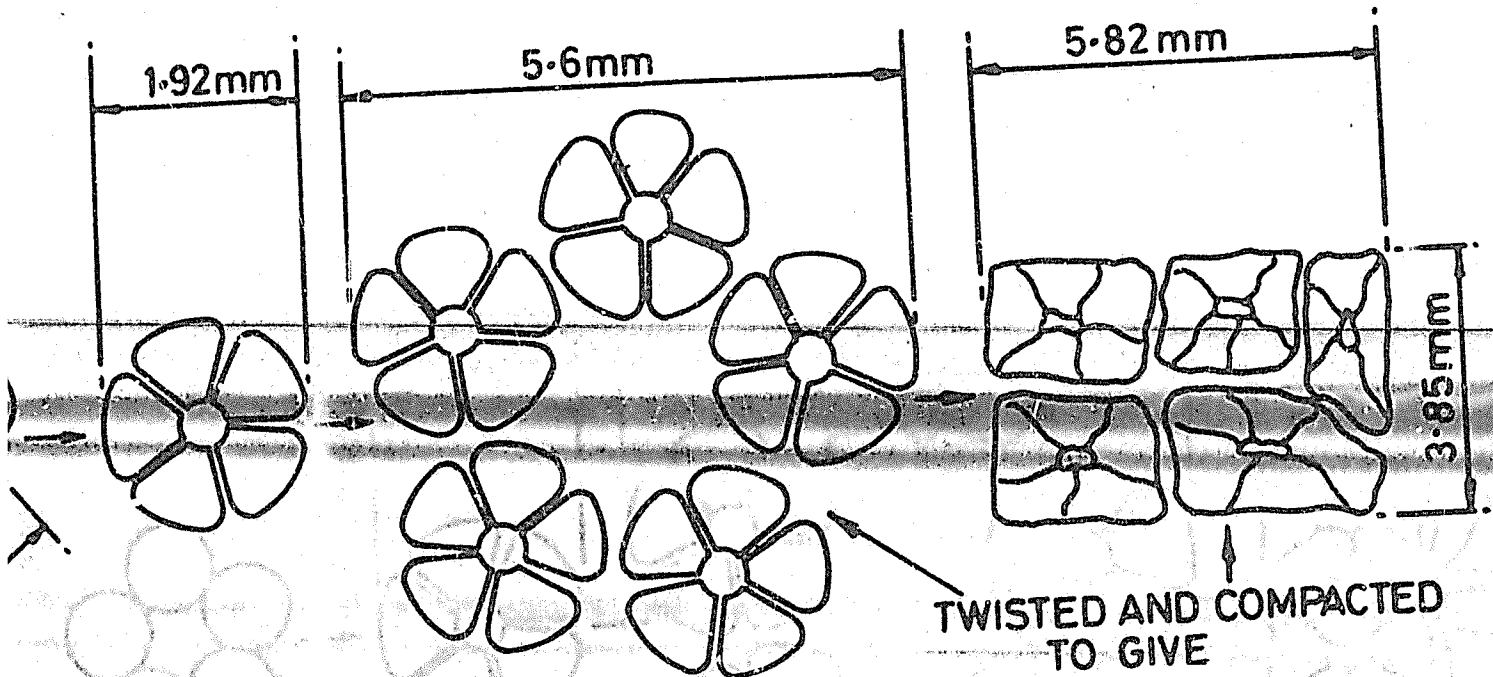

FIG. 3a. AC IV, 25 STRAND - RECTANGULAR SECTION CABLE



TWISTED AND COMPACTED TO GIVE

FINAL STATE

INITIAL STATE

FINAL STATE

STAGE (5 x 5)

GE (5) →
G. 3a. AC IV, 25 STRAND - RECTANGULAR SECTION CABLE

INITIAL STATE

FINAL STATE

TWISTED AND COMPACTED TO GIVE

3.85 mm

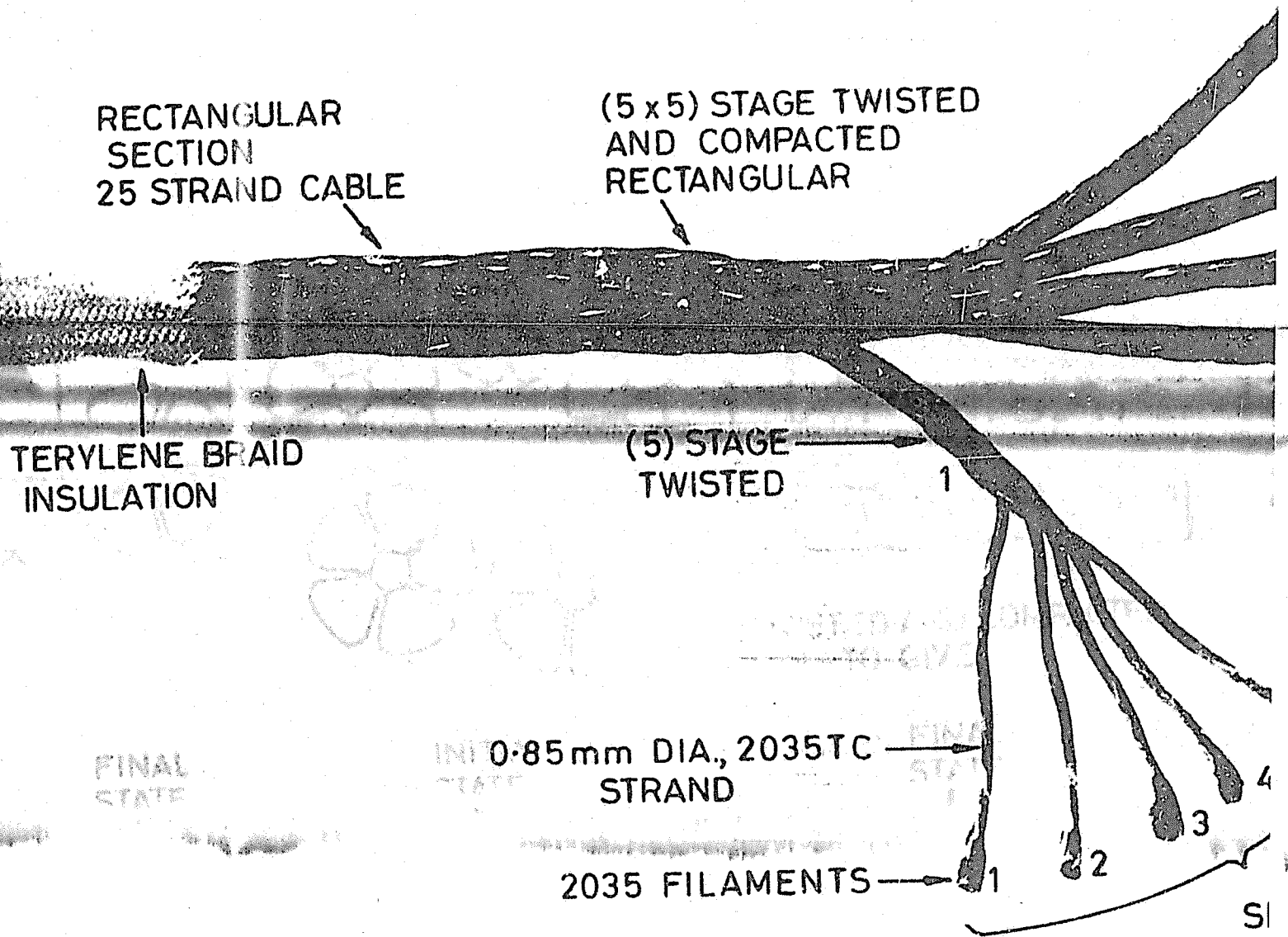

Fig. 3b View of ACIV cable

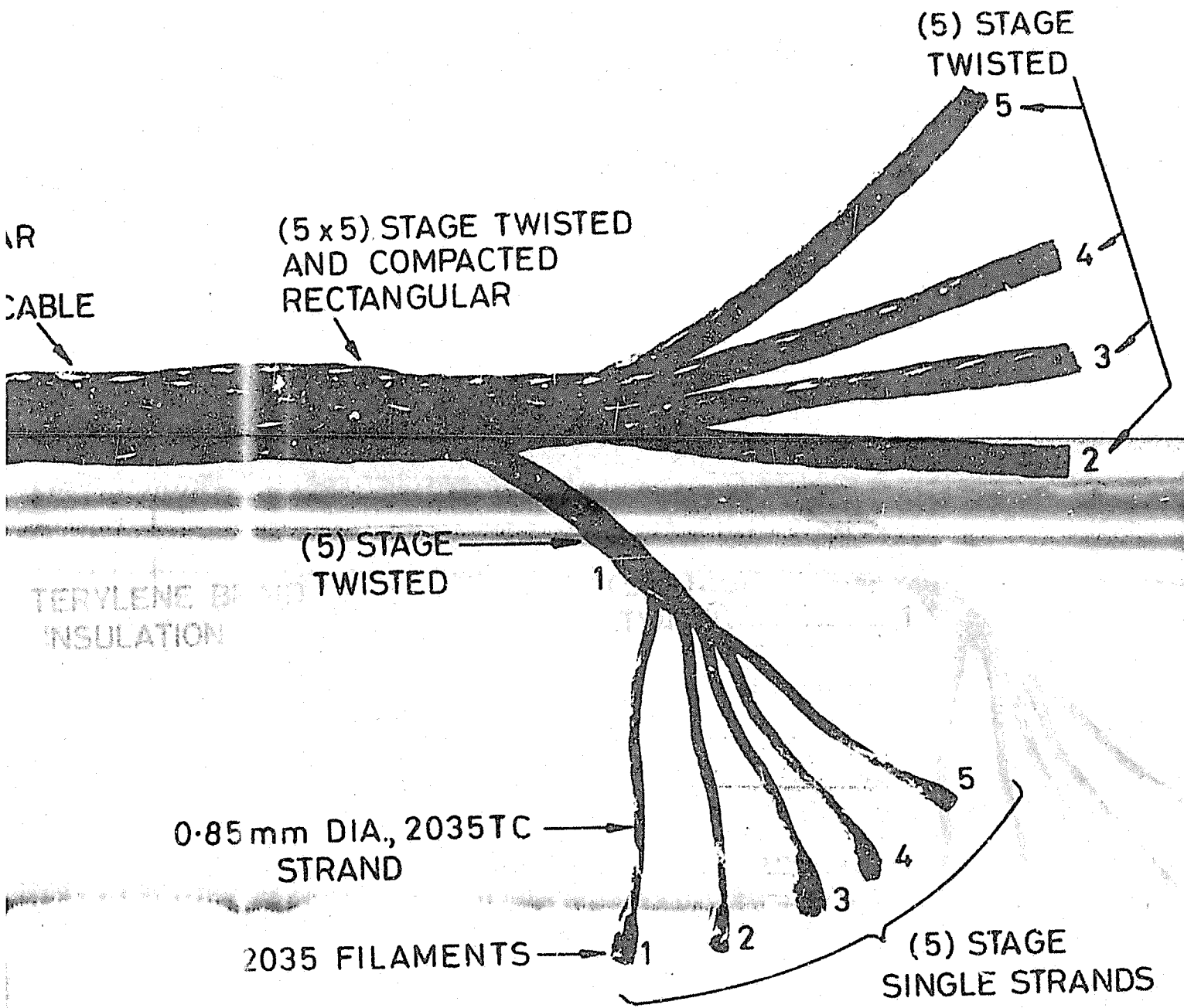

Fig. 3b View of ACIV cable

2035TC
 2035TC
 2035TC

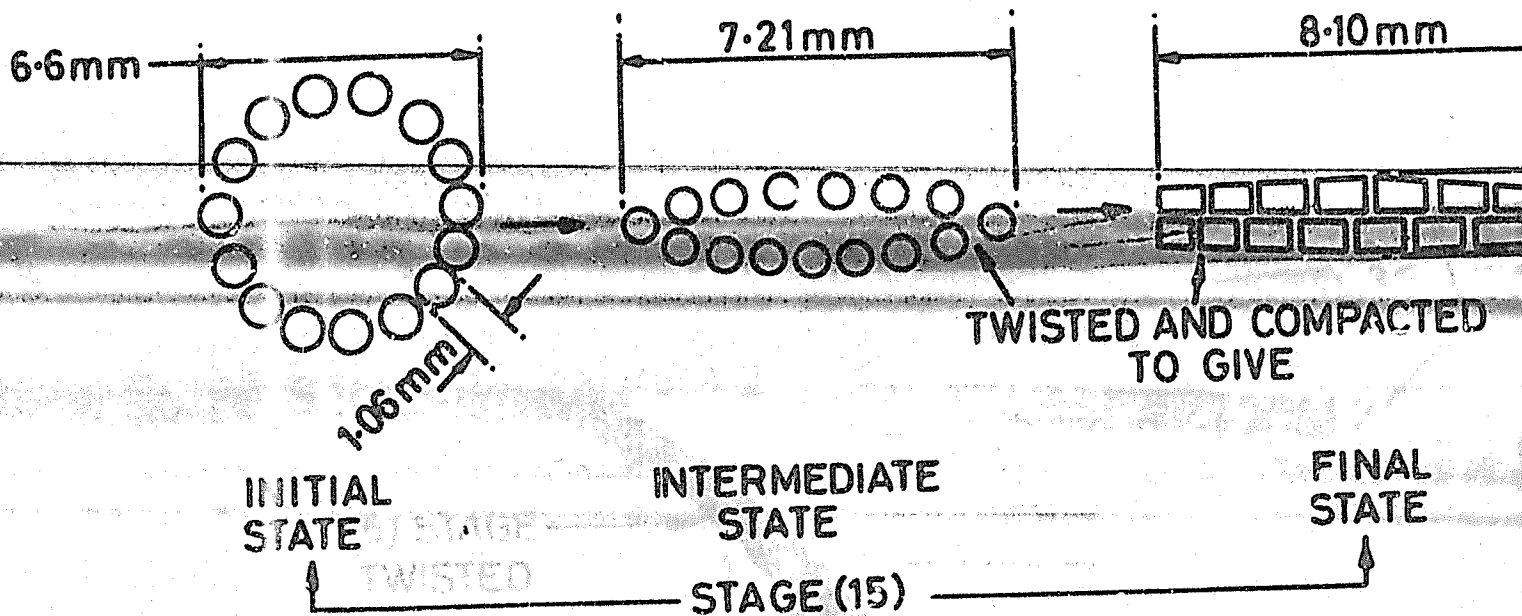

FIG. 4a. AC V 15 STRAND - LOZENGE SECTION CABLE

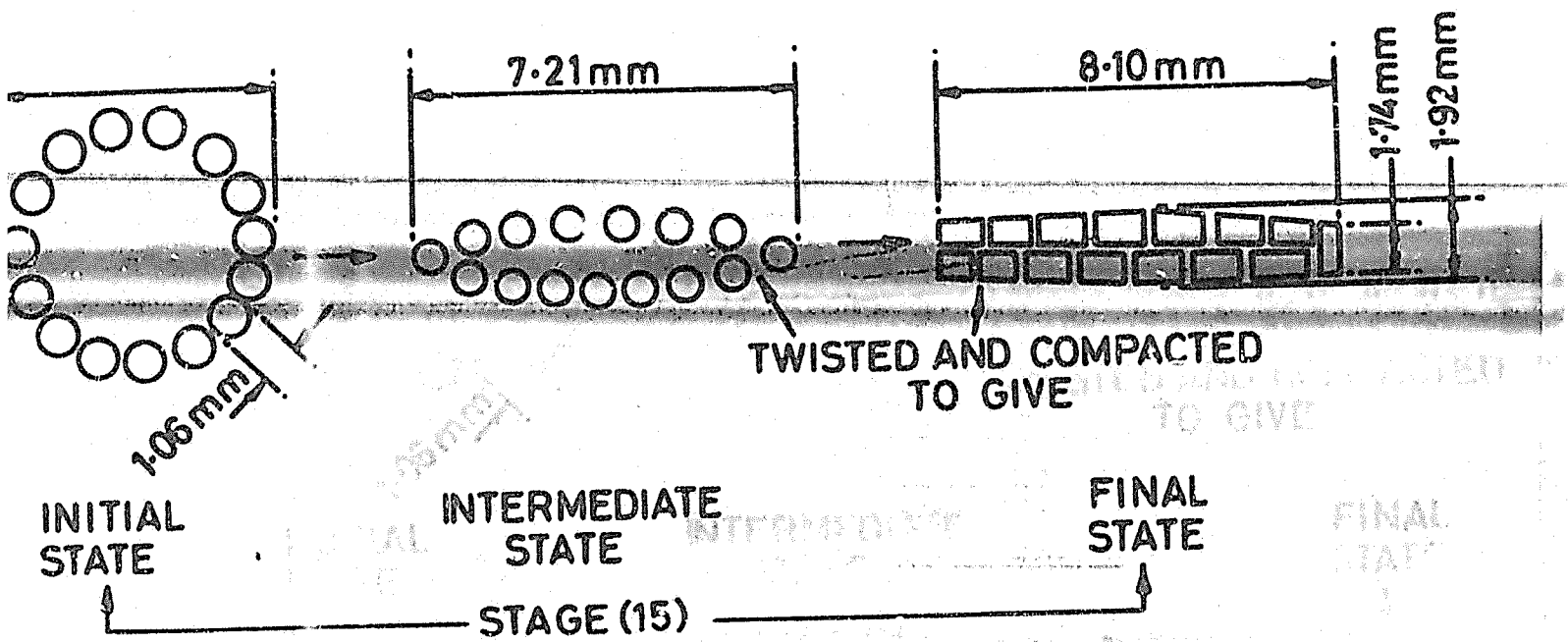
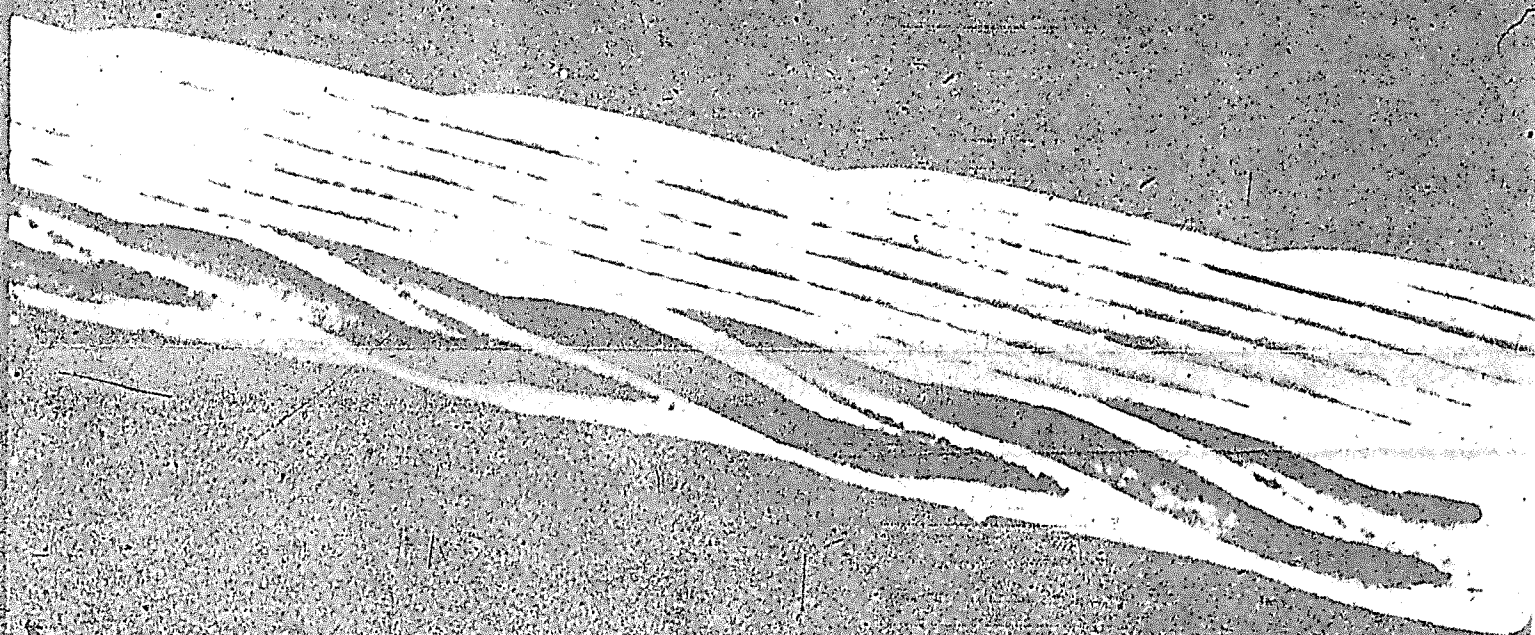

FIG.4a. AC V 15 STRAND - LOZENGE SECTION CABLE



00000000
000000

00000000

00000000

Fig. 4b Views of ACV cable (Side view)



Fig. 4b Views of ACV cable (Side view)

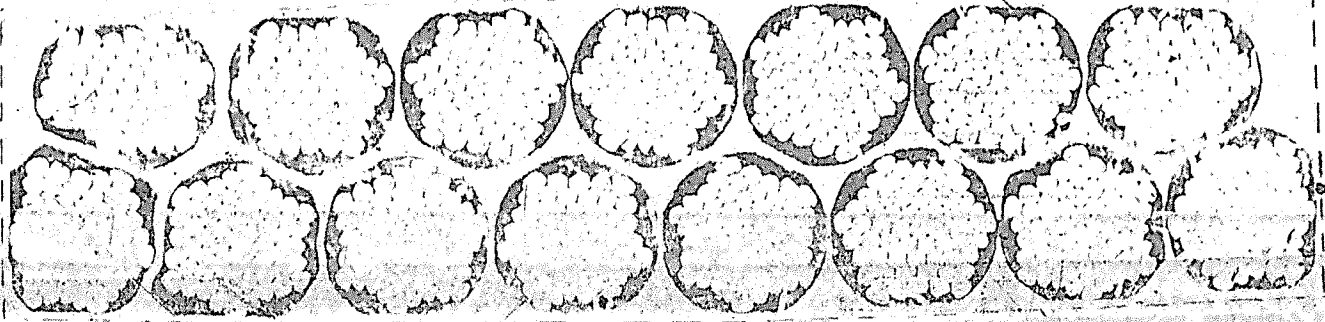

Fig. 4b Views of ACV cable (End view)

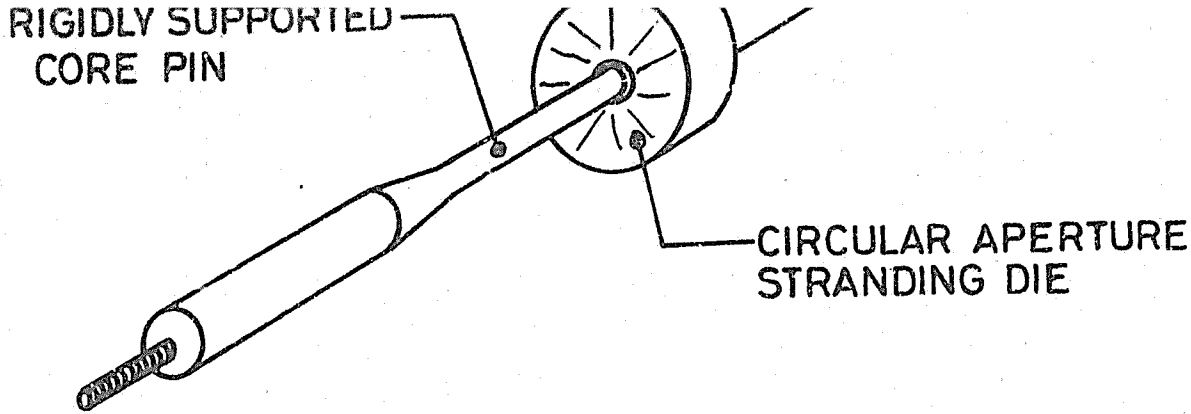

FIG. 5. ASSEMBLY SEQUENCE OF SPECIAL TOOLS
A.C.V. CABLE M.F.R.

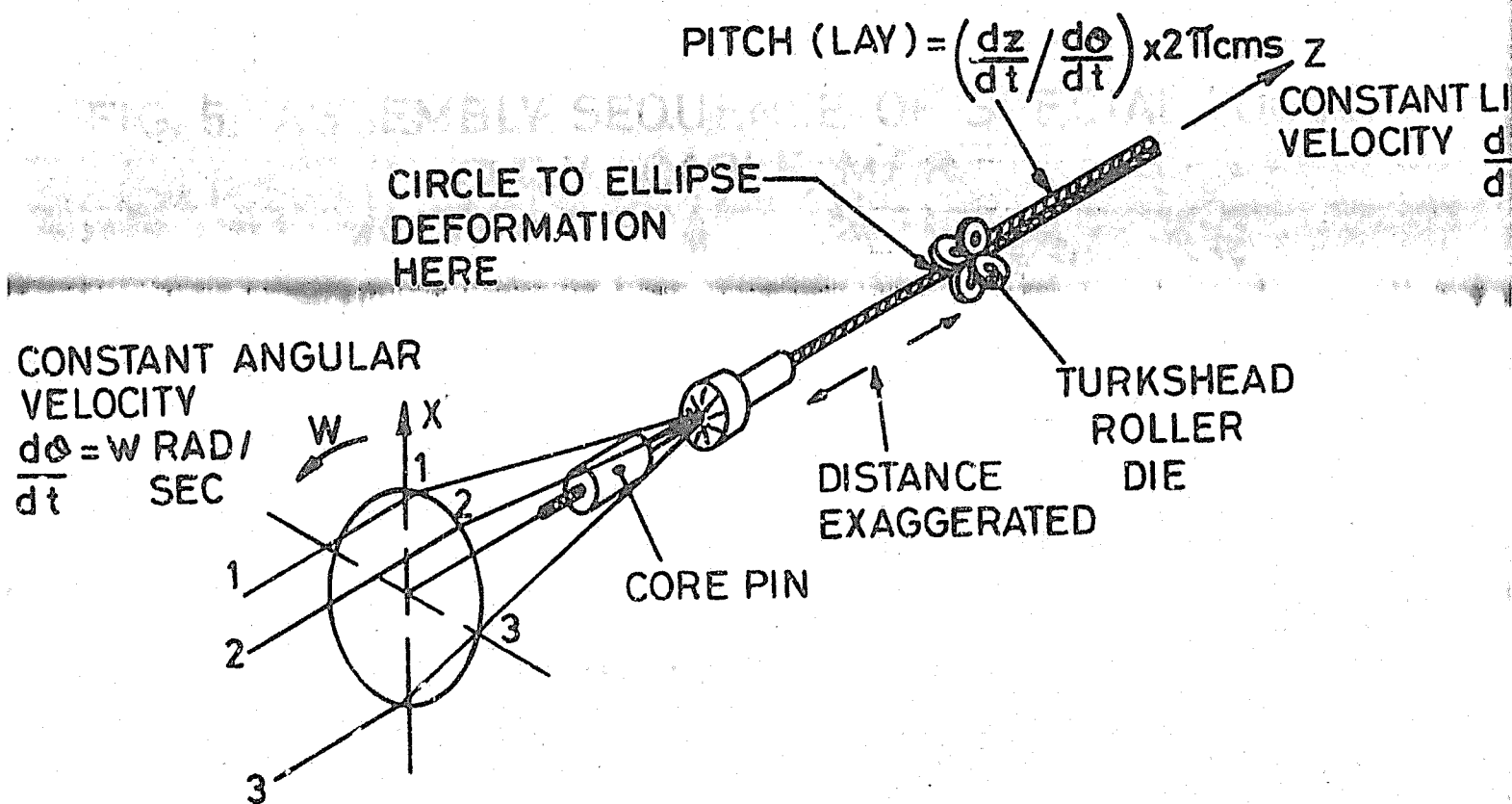

FIG. 6. SEQUENCE OF OPERATIONS A.C.V. CABLE M.F.R.

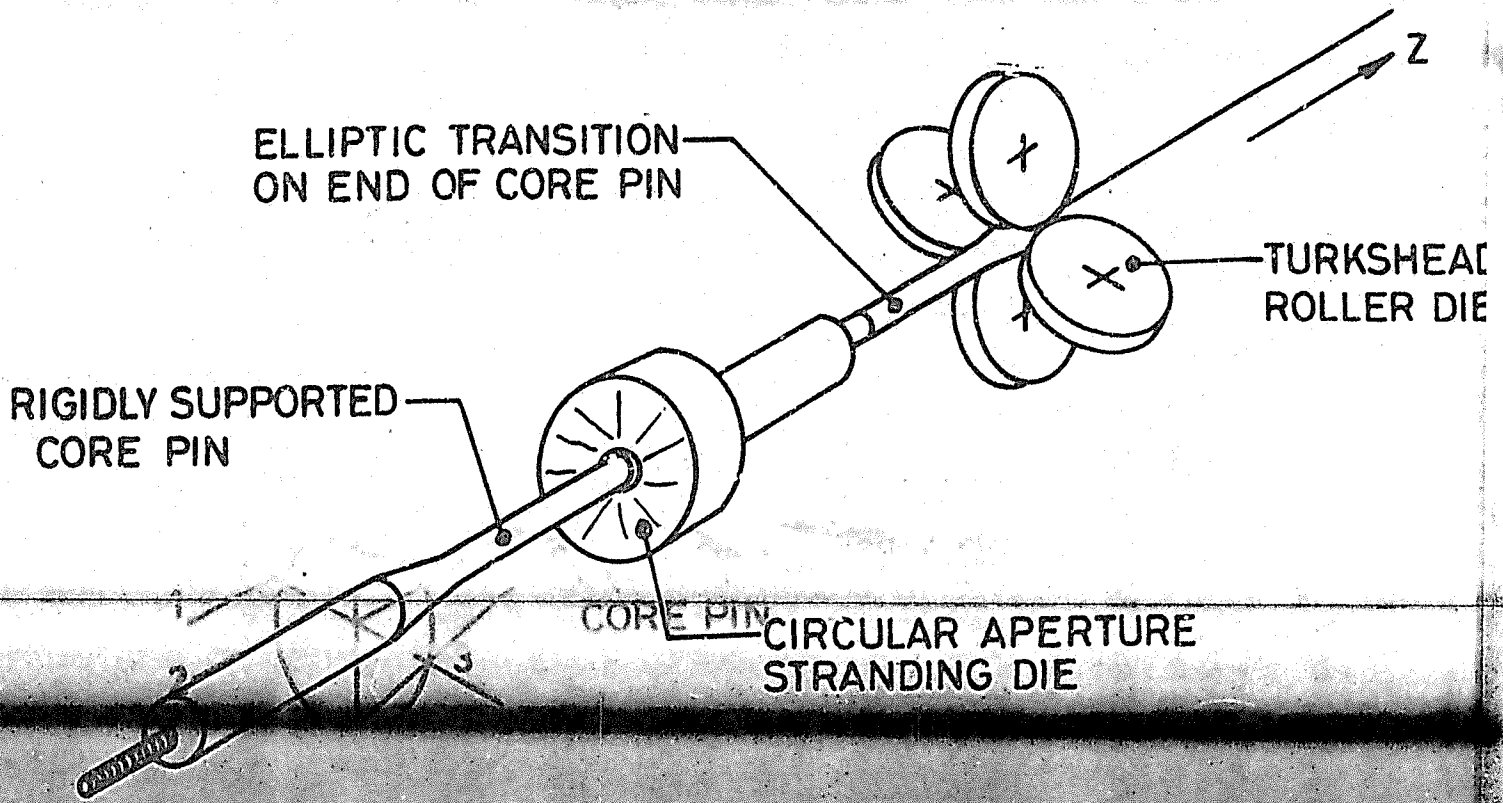
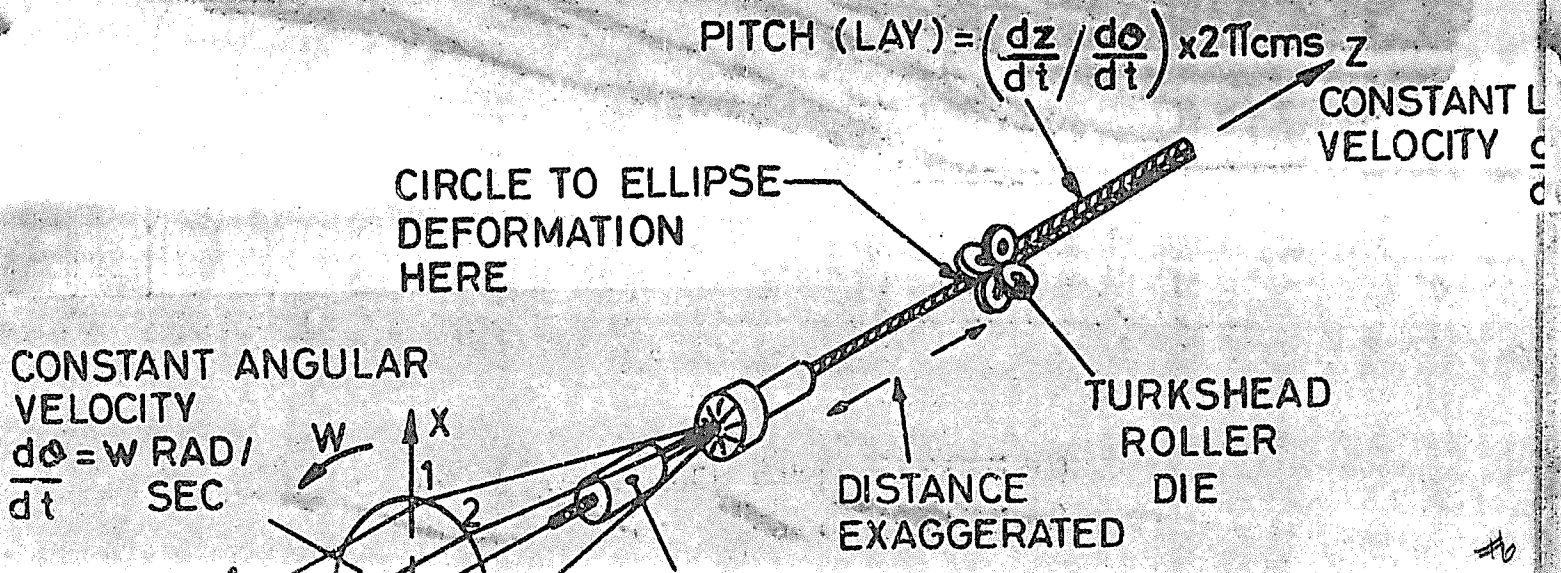
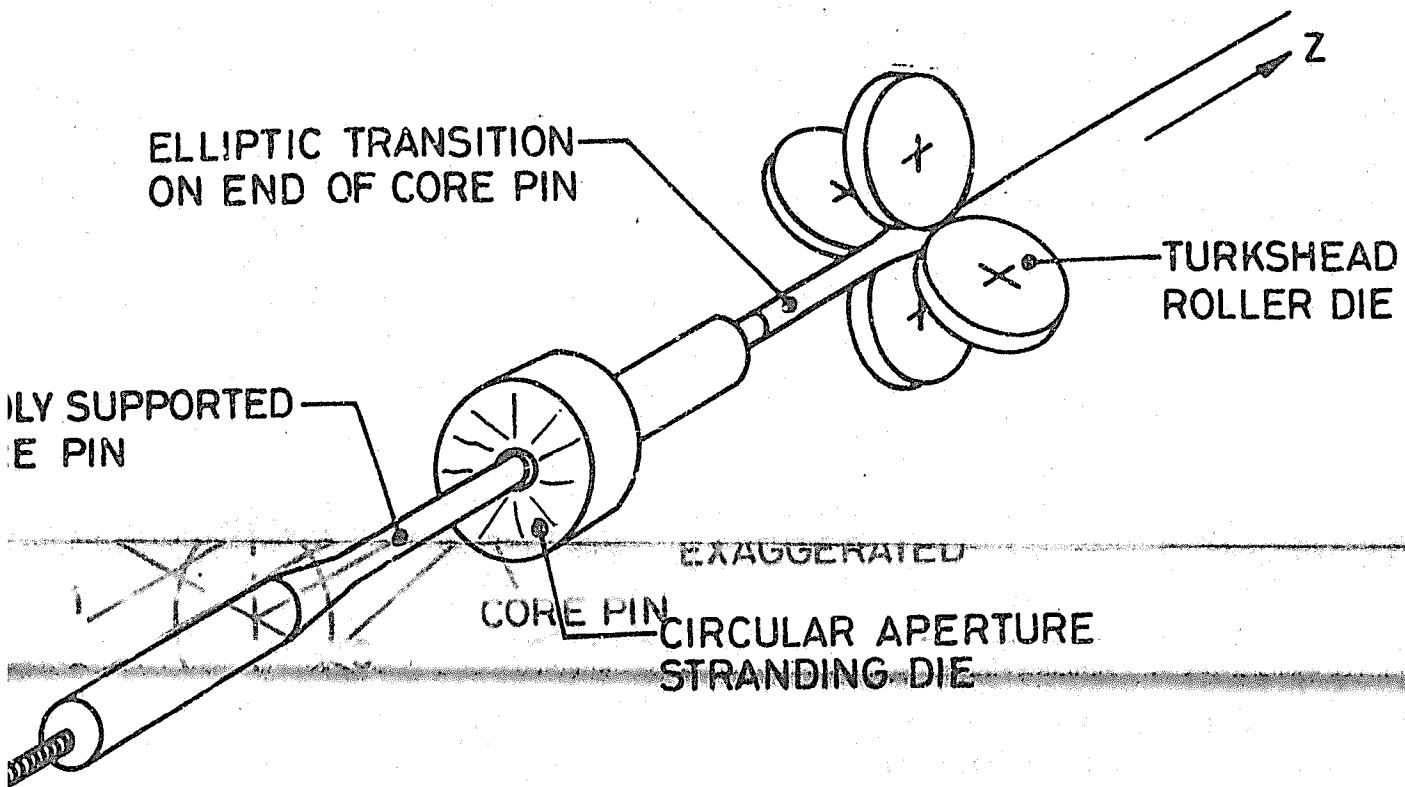
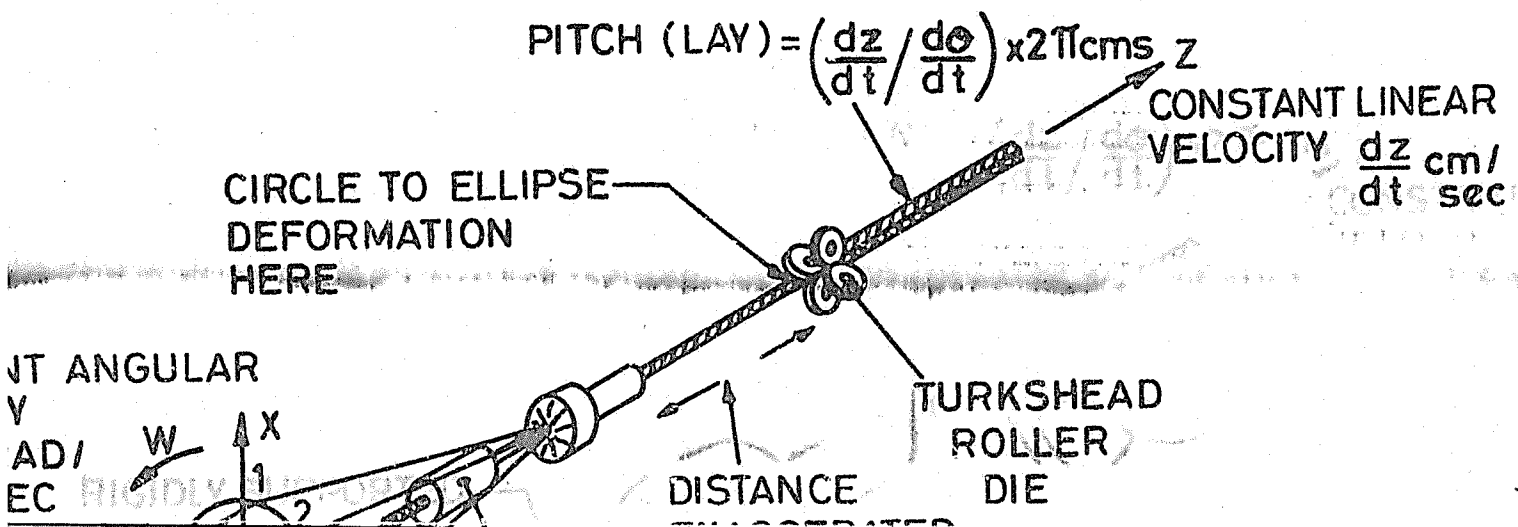

FIG. 5. ASSEMBLY SEQUENCE OF SPECIAL TOOLS
A.C.V. CABLE M.F.R.





5. ASSEMBLY SEQUENCE OF SPECIAL TOOLS A.C.V. CABLE M.F.R.



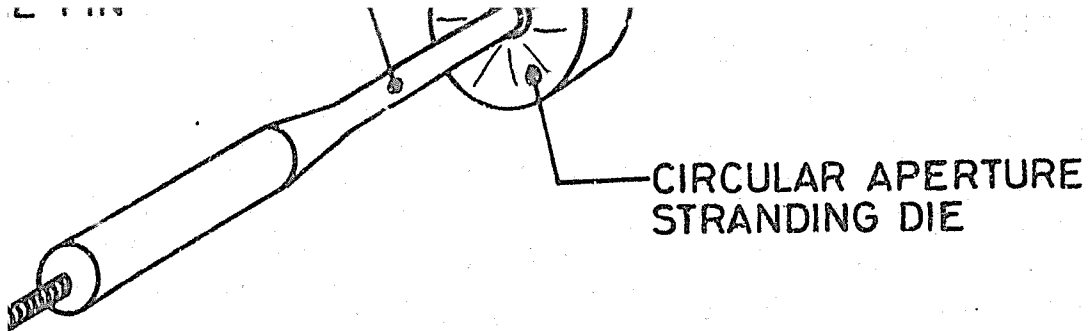

5. ASSEMBLY SEQUENCE OF SPECIAL TOOLS A.C.V. CABLE M.F.R.

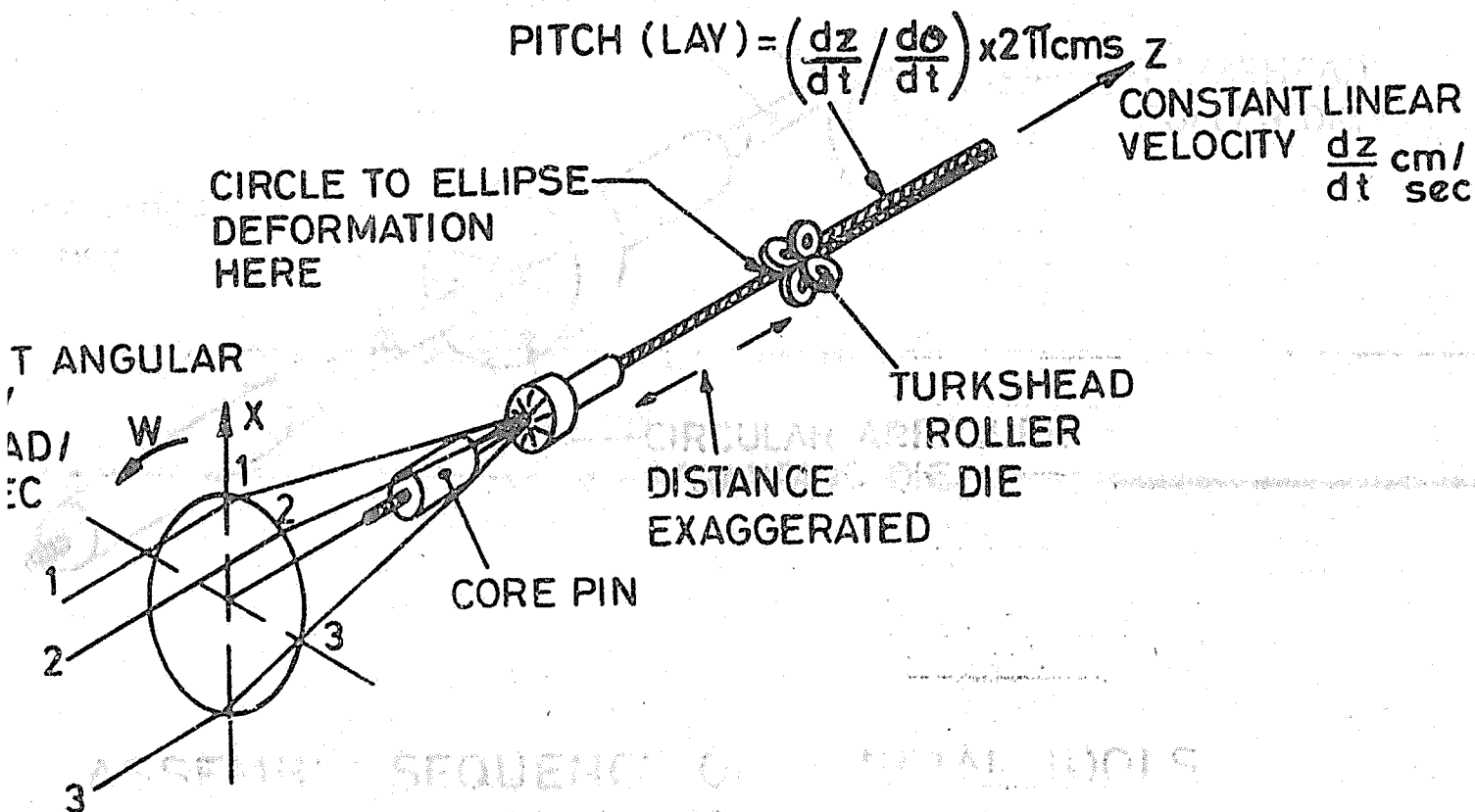

6. SEQUENCE OF OPERATIONS A.C.V. CABLE M.F.R.

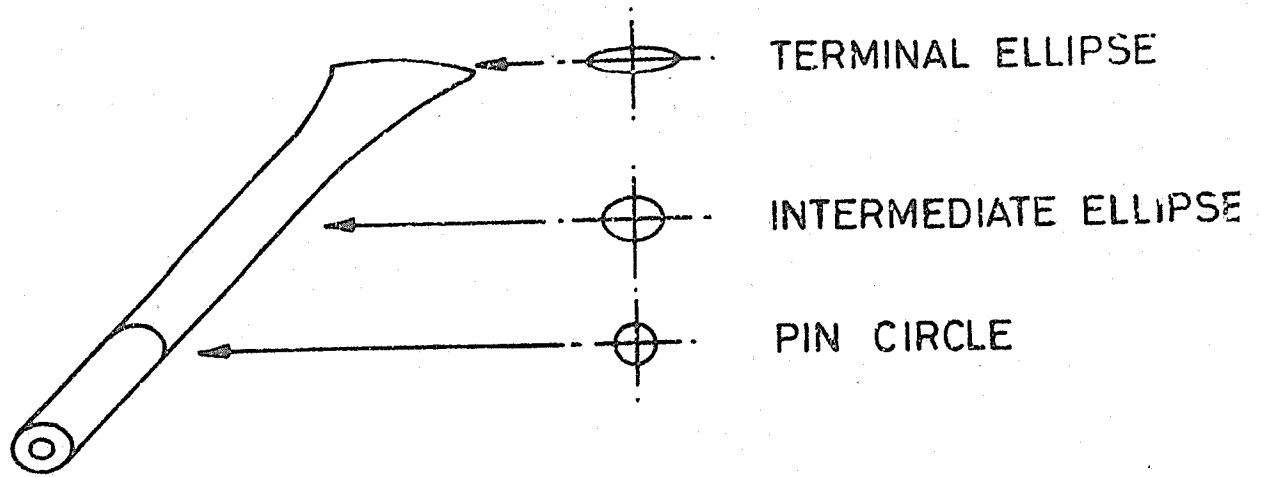

FIG. 7. CORE PIN TRANSITION

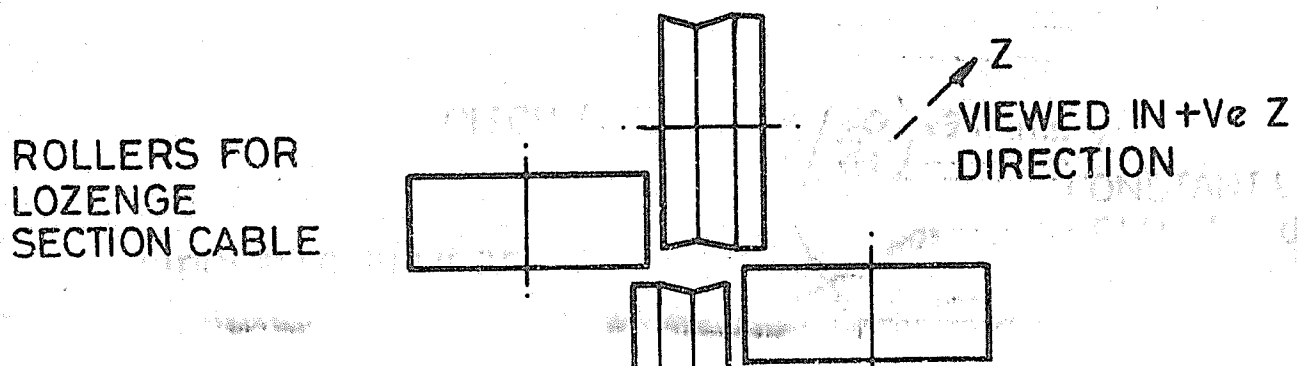
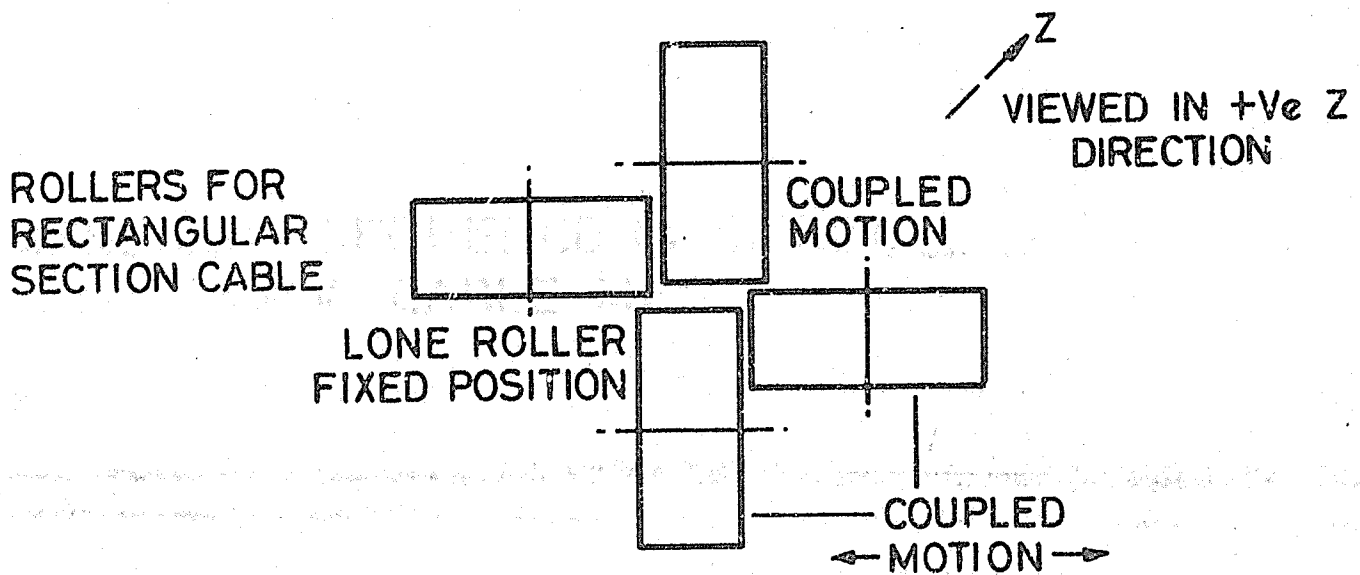

FIG. 7. CORE PIN TRANSITION

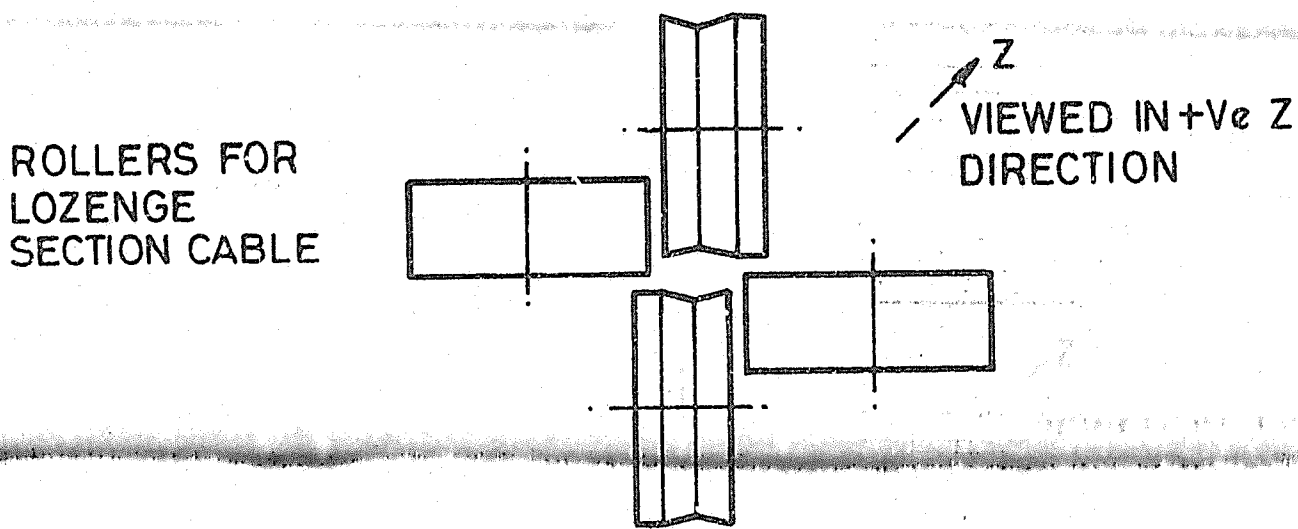
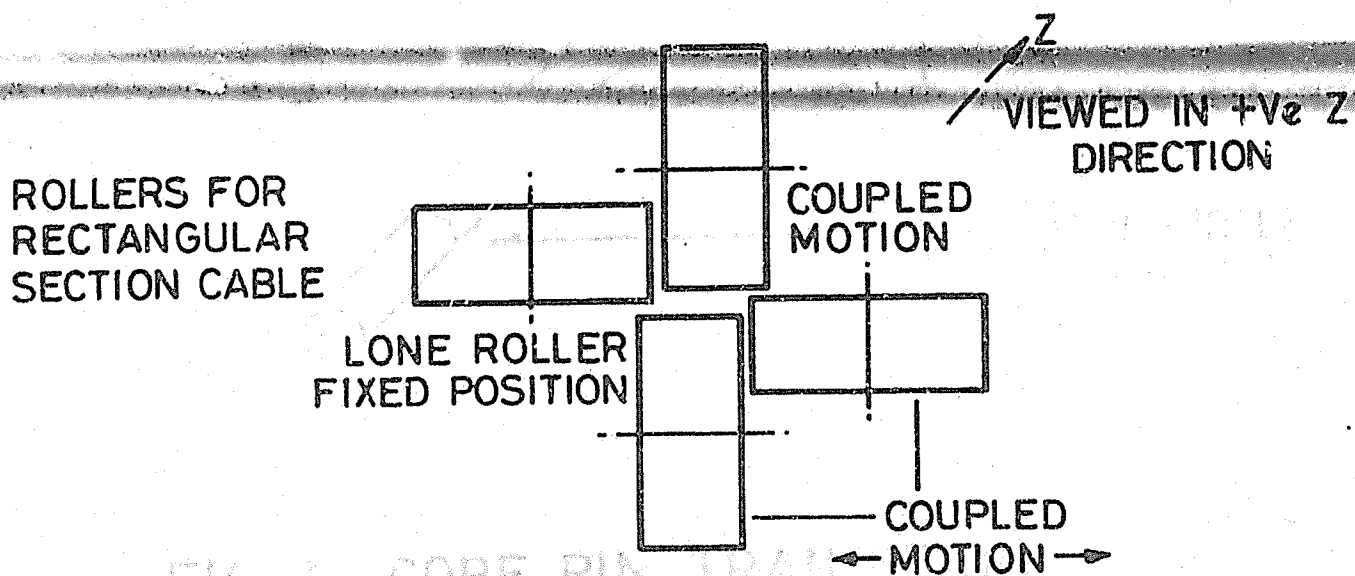

FIG. 8. TURKSHEAD ROLLER DIE

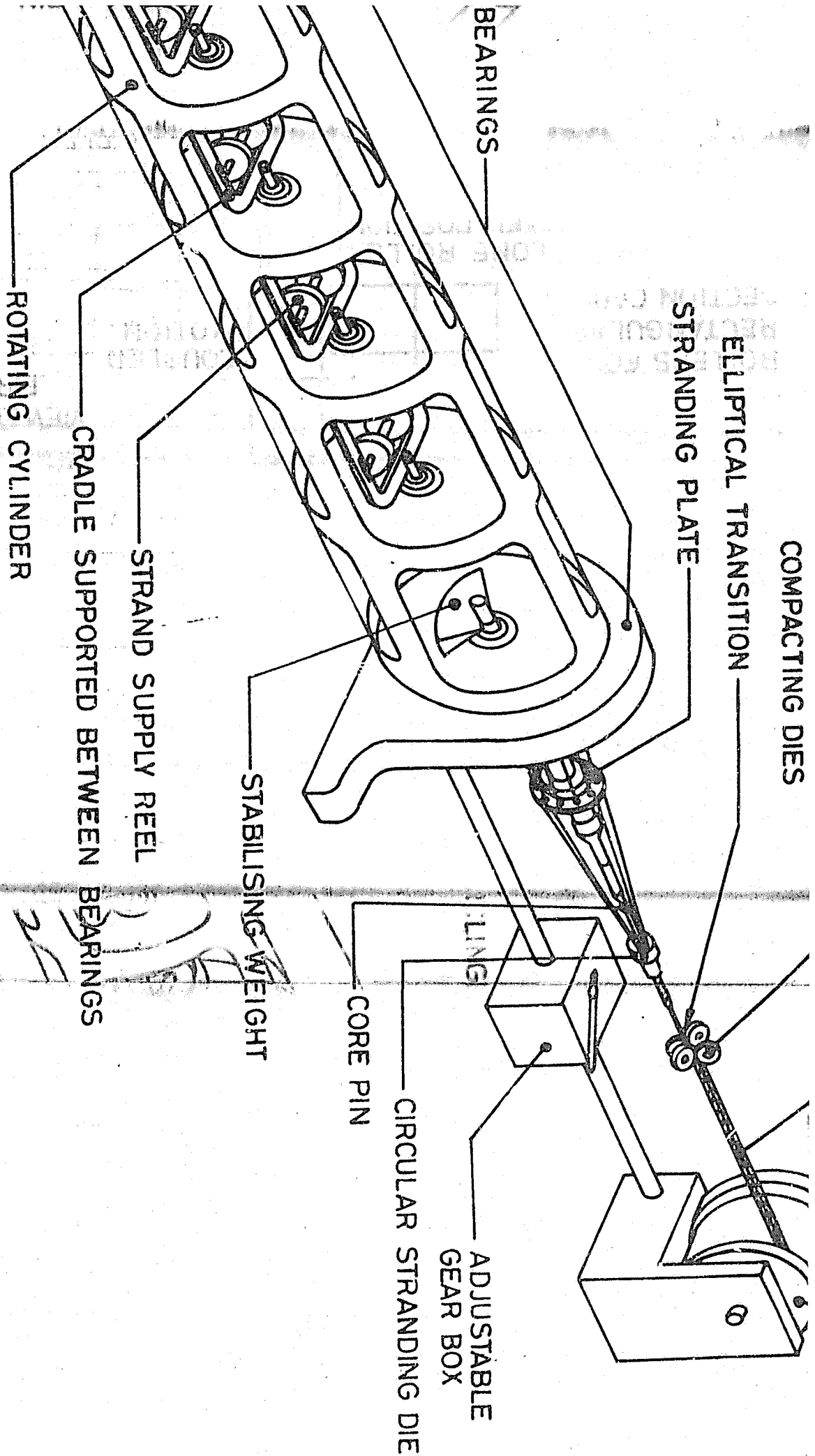

FIG. 9. TUBULAR STRANDING MACHINE ADAPTED FOR A.C.V. CABLE M.F.R.

E MOTOR

#9

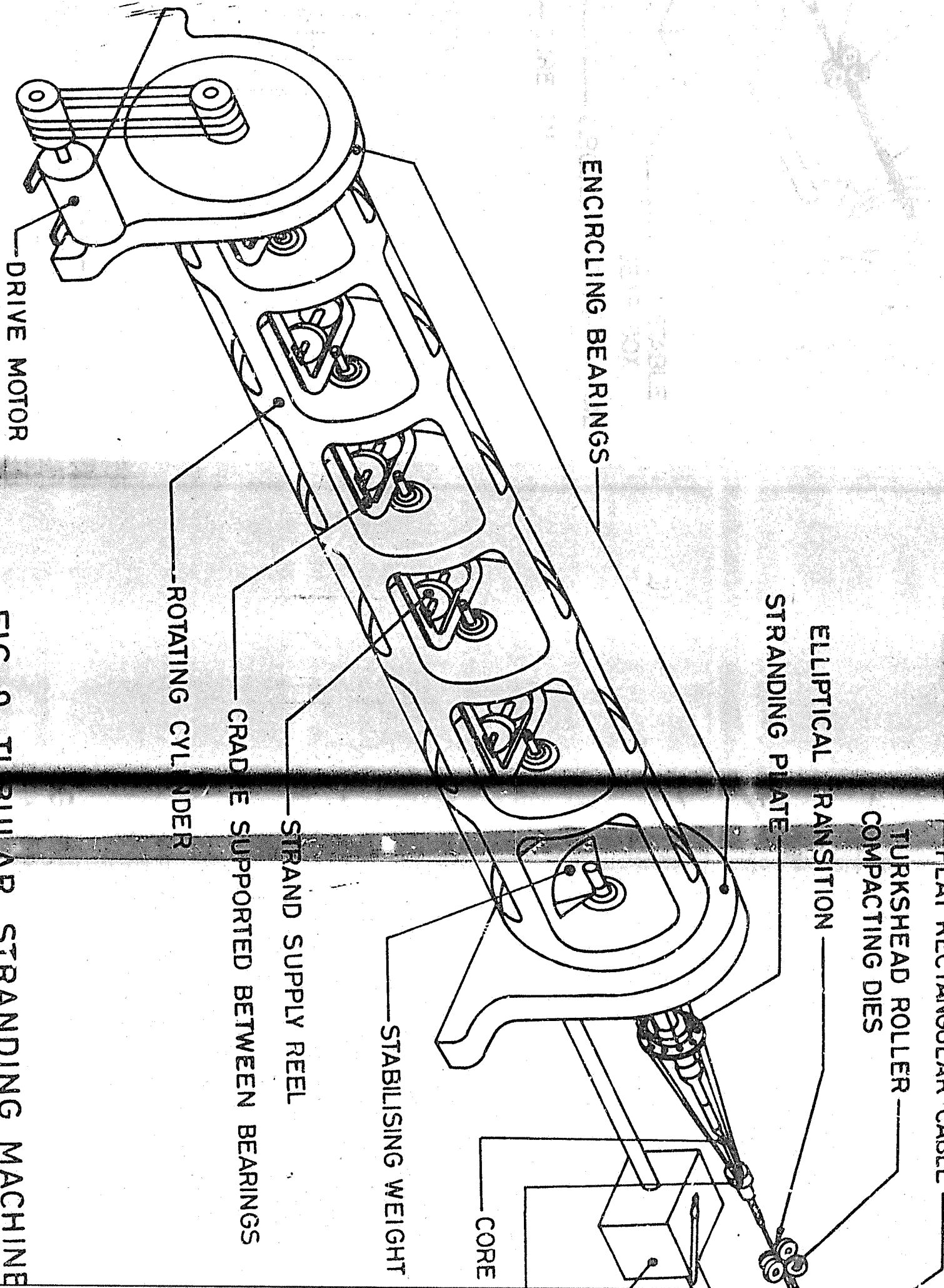

FIG. 9. TUBULAR STRANDING MACHINE
 END RECIPROCATORY CABLE

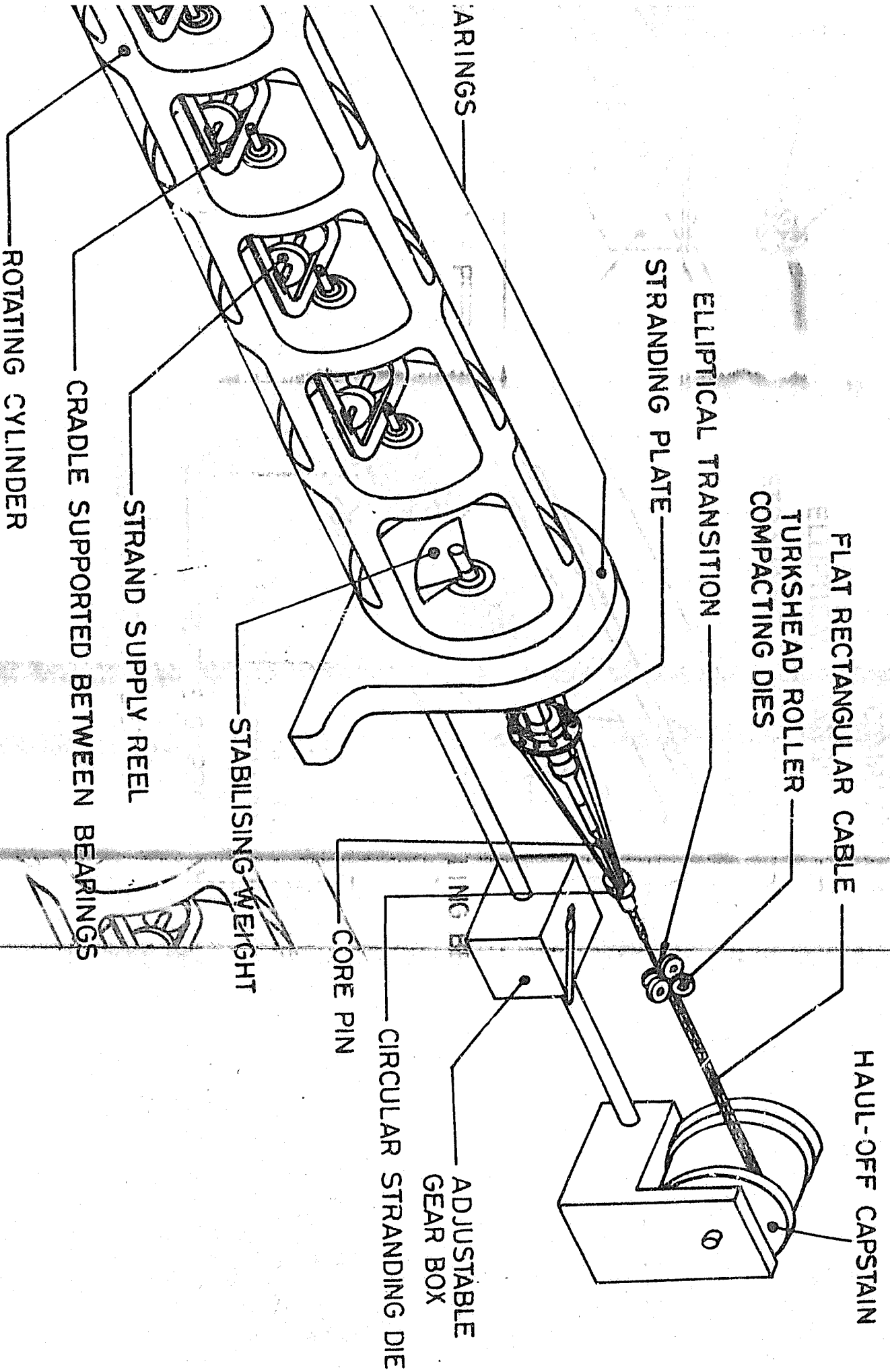

FIG. 1

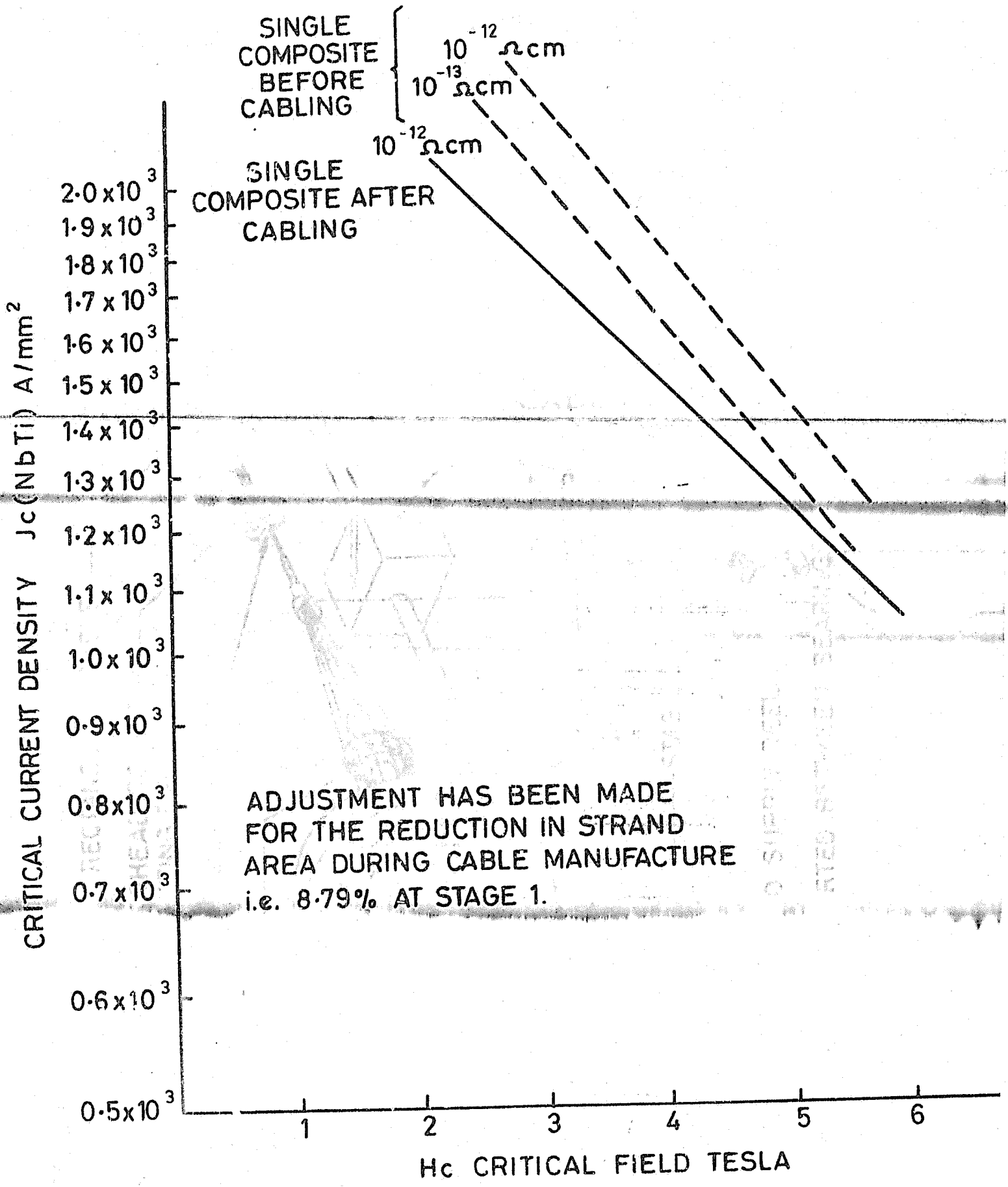

FIG. 10. AC III STRAND PERFORMANCE BEFORE AND AFTER CABLING

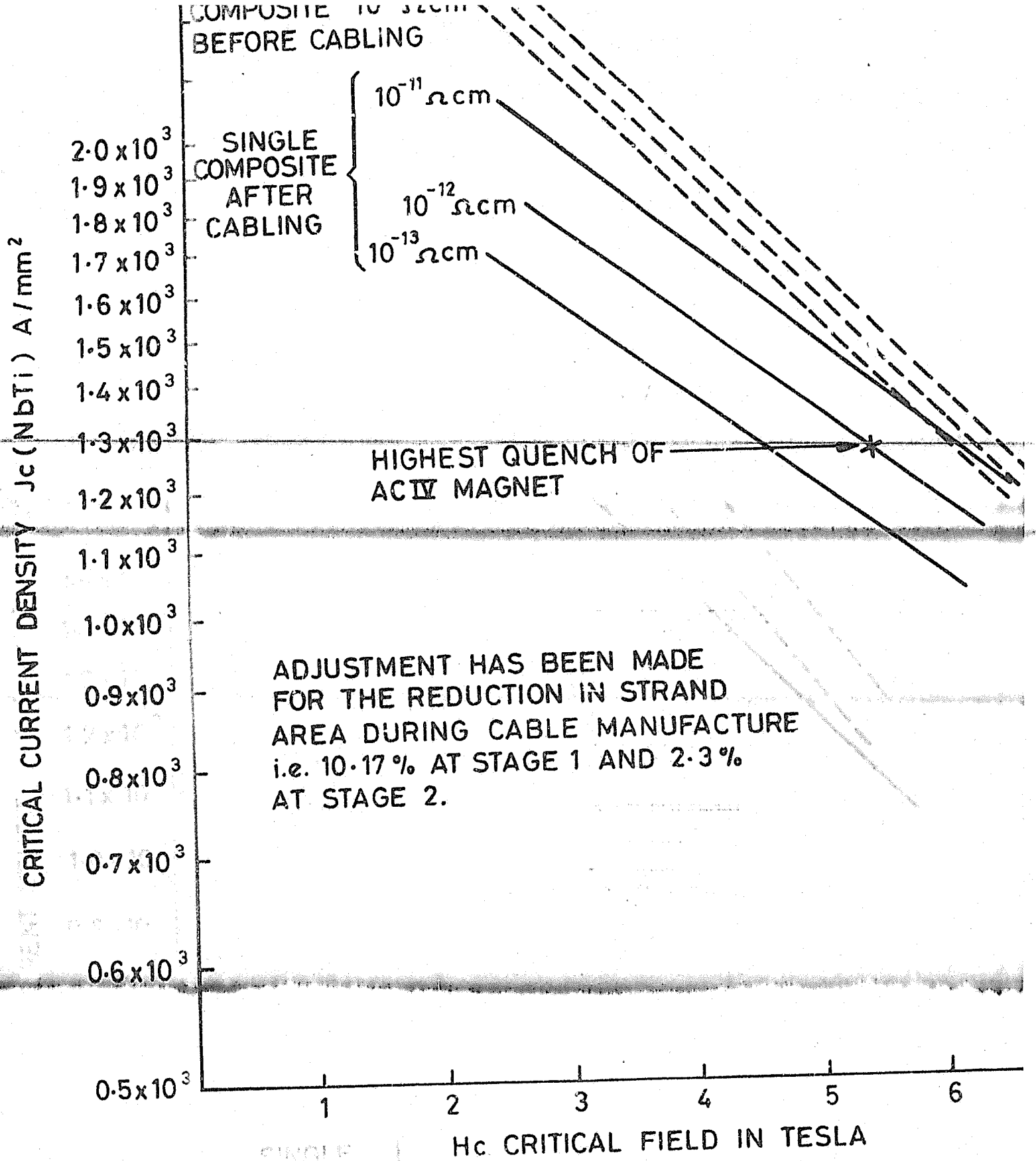
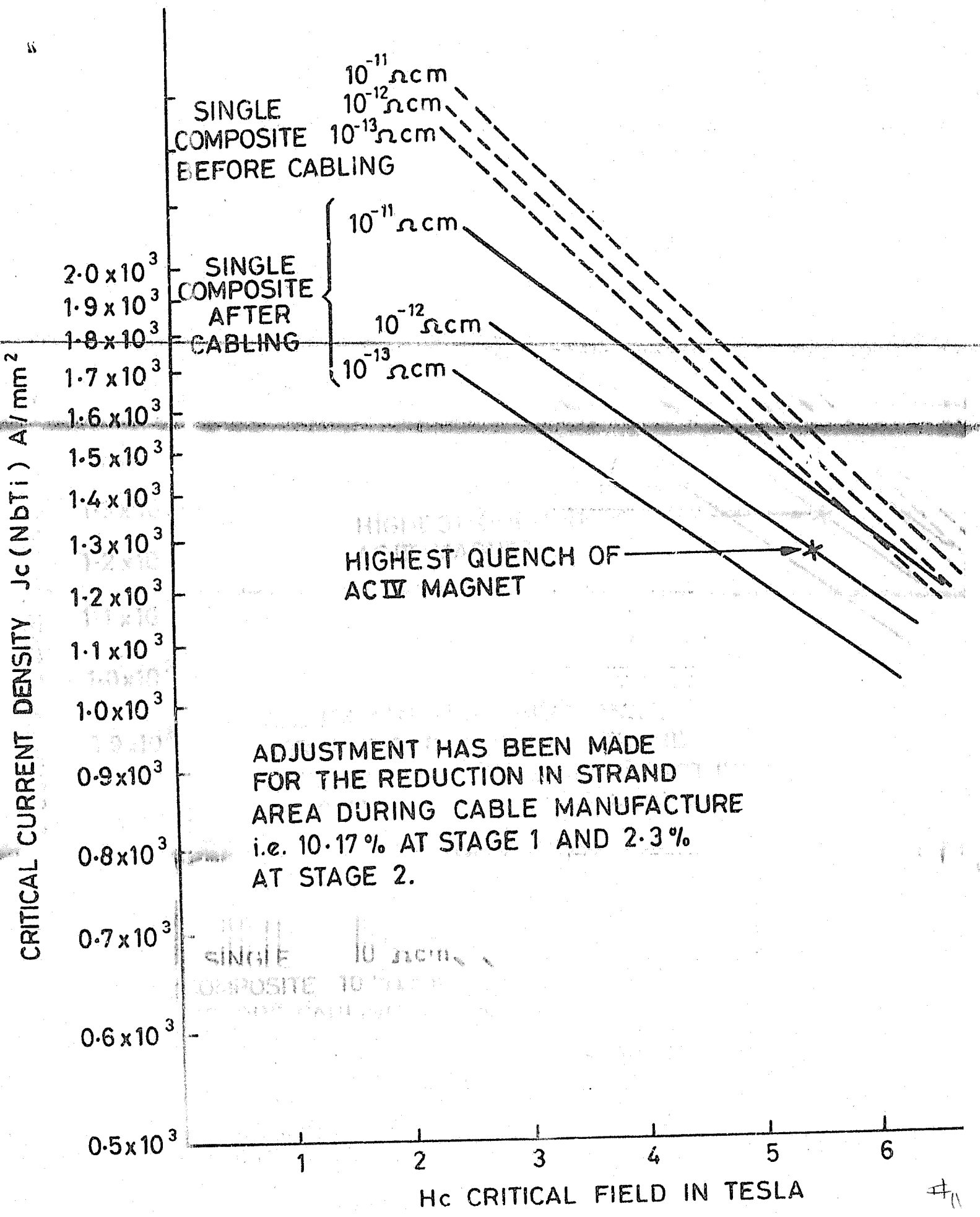

FIG. 11. AC IV STRAND PERFORMANCE BEFORE AND AFTER CABLING



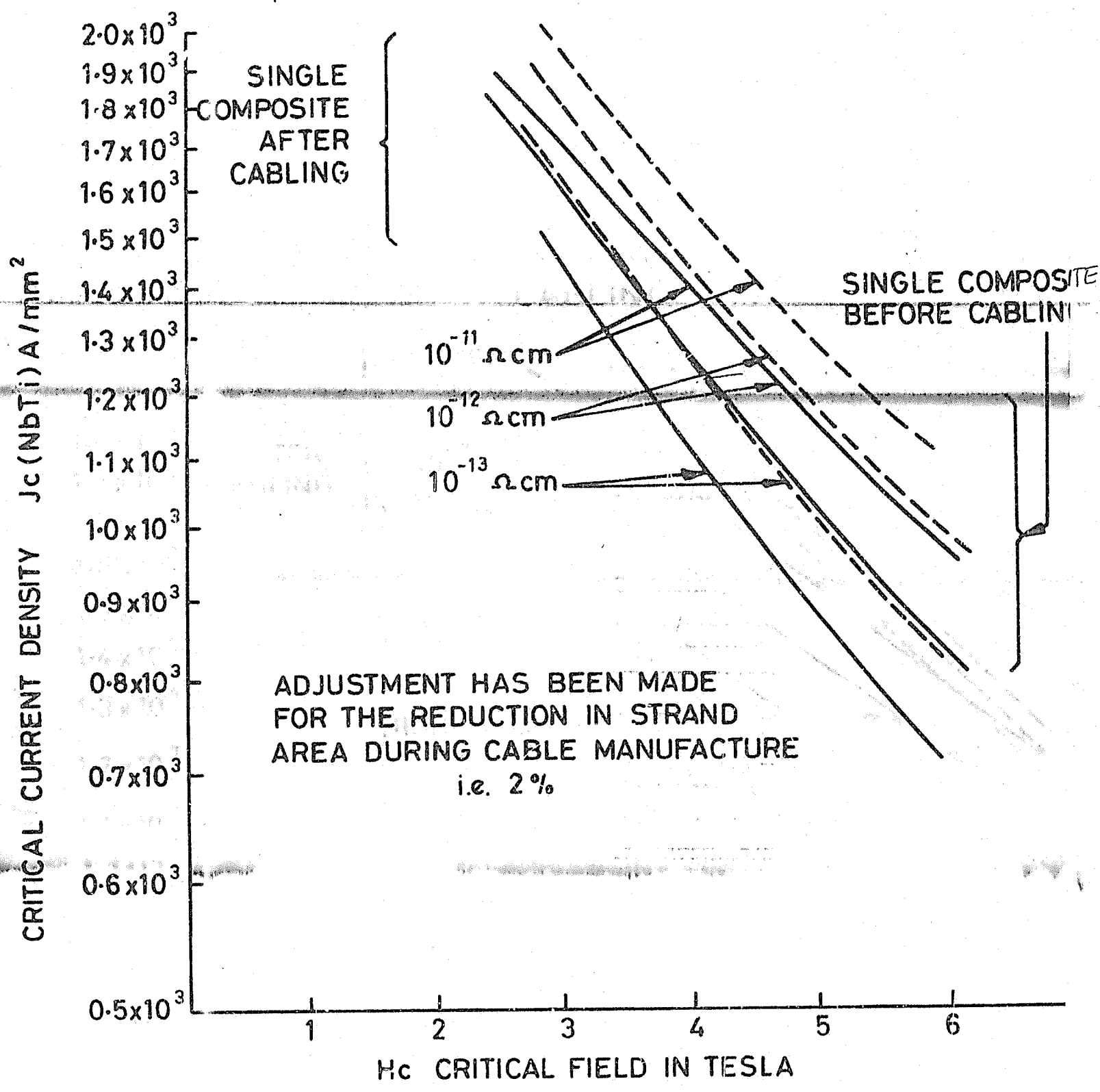

FIG. 12. ACII STRAND PERFORMANCE BEFORE AND AFTER CABLING

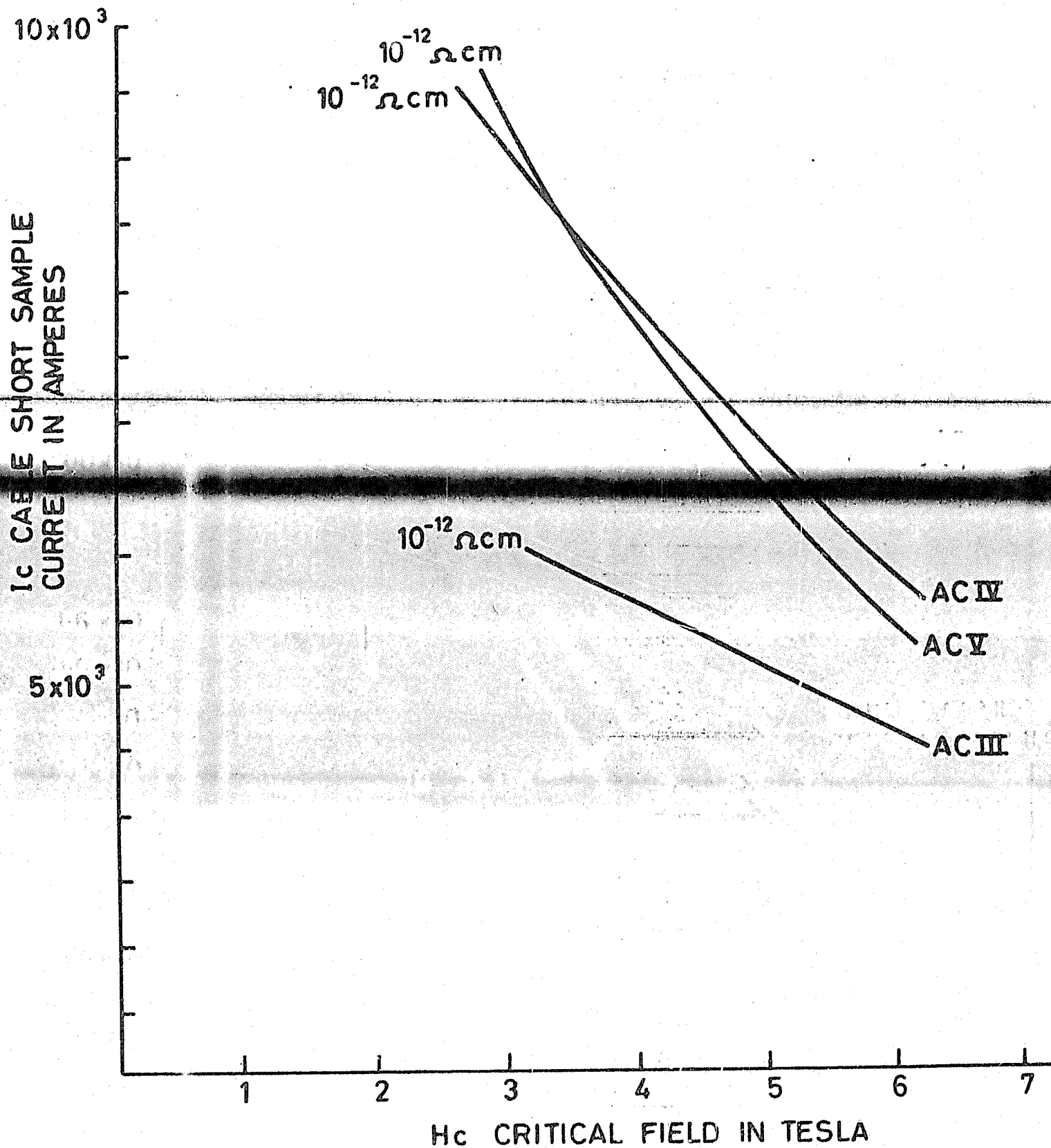

FIG. 13. SHORT SAMPLE PROPERTIES: ACIII, IV AND V CABLES