

TECHNICAL OVERVIEW OF BUNCH COMPRESSOR SYSTEM FOR PAL XFEL

H.G. Lee, D.H. Na, S.B. Lee, B.G. Oh, Y.J. Seo, H.S. Suh, Y.G. Jung, D.E. Kim, K.H. Park, H.S. Kang, K.W. Kim
Pohang Accelerator Laboratory, POSTECH, Korea

Abstract

Pohang Accelerator Laboratory(PAL) is developing a SASE X-ray Free Electron Laser based on 10 GeV linear accelerator. Bunch compressor (BC) systems are developed to be used for the linear accelerator tunnel. It consists of three(BC1, BC2, BC3_H) hard X-ray line and one(BC3_S) soft X-ray line. BC systems are composed of four dipole magnets, three quadrupole magnet, BPM and collimator. The support system is based on an asymmetric four-dipole magnet chicane in which asymmetry and variable R_{56} can be optimized. This flexibility is achieved by allowing the middle two dipole magnets to move transversely. In this paper, we describe the design of the stages used for precise movement of the bunch compressor magnets and associated diagnostics components.

INTRODUCTION

A bunch compressor support system has been fabricated and tested for the PAL XFEL. The machine of the PAL XFEL consists of four main sections: the linear accelerator, the hard x-ray undulator hall, the soft x-ray undulator hall and the experimental area. The accelerator, schematically shown in Figure 1, comprises the gun, the laser heater, four accelerating sections groups (L1–L4), four bunch compressors (BC1, BC2, BC3_H and BC3_S) and the spreader. The physics design of the magnetic bunch compressor is based on an asymmetric four-dipole chicane configuration [1]. The BC purpose is to reduce the electron bunch length, thus increasing the peak current, taking advantage of the beam correlated energy spread. Due to the accelerating process, there is an inherent longitudinal energy spread in the electron bunch. Passing through four bending magnets chicane, the path length is energy dependent and the electron bunch is compressed. At each bend, the electron bunch head delays with respect to the tail. Mounting high homogeneity magnetic field dipoles and having diagnostic devices centre on the beam at each chicane position are the main advantages of the movable chicane.

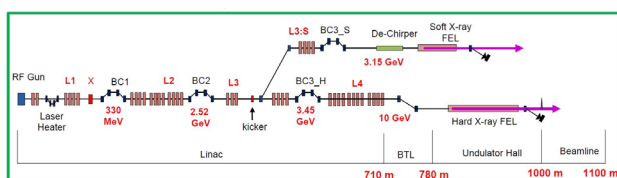

Figure 1: The schematic layout of the 3-BC lattice.

BUNCH COMPRESSOR OVERVIEW

The BC support system, shown in Figure 2 and Table 1, consist of four dipole magnets (DM), two tweak quadrupole magnets and a skew quadrupole magnet, two corrector magnets, BPM, collimator, screen and CSR monitor. The position of such diagnostic devices remains fixed with respect to the central dipoles.

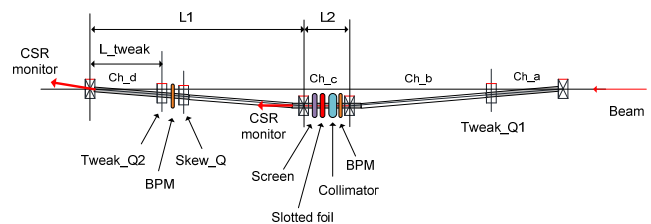

Figure 2: Layout of the BC support system.

Table 1: Major Parameters of the BC Support System

	BC1	BC2	BC3 H	BC3 S
Dipole angle, deg	4.9	3.0	1.7	1.7
Dipole length, m	0.2	0.7	0.7	0.7
L1, m	4.4845	7.1905	7.597	6.397
L2, m	1.2	1.8	1.8	1.8
L_tweak, m	1.146	1.3483	2.349	1.349
Aperture diameter of Tweak Quad, mm	44 (Q11)	44 (Q11)	44 (Q11)	44 (Q11)

The support systems of BC are composed of two fixed support and a moving support. The two central dipoles are mounted on a moving support that can have up to 627.0 mm motion orthogonal to the beam axis. A servo motor provides movement to the central stage and a linear encoder controls its exact position. The position accuracy of dipoles is within 50 μ m.

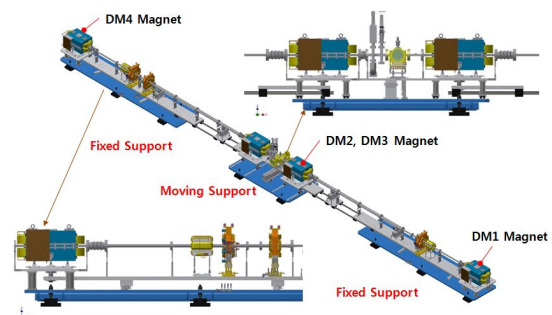

Figure 3: 3D modelling of BC support system.

The chicane is symmetric (DM1–DM2 distance is equal to DM3–DM4 distance). Tweak Q1 (Q2) is placed between DM1 (DM3) and DM2 (DM4). The quadrupole magnets rotate and remain at a fixed distance from the pivot points DM1 and DM4. Figure 3 shows the BC layout and its overall 3D modeling.

MAGNET DESCRIPTION

Dipole magnet for the bunch compressor is applied two types, D1 and D2. D1 is used for BC1 and D2 is used for BC2, BC3_H, BC3_S. The distance of the offset of each magnet is different in BC system. Table 2 is shows the offset distance of each dipole magnet in BC from the center line of the Beam. Figure 4 shows the modelling of dipole magnet D1.

Table 2: The Offset Distance of Dipole Magnets

	Magnet Type	DM1	DM2	DM3	DM4
BC1	D1(mm)	5.13	2.83	2.83	5.13
BC2	D2(mm)	11.00	6.03	6.03	11.00
BC3_H	D2(mm)	6.23	3.42	3.42	6.23
BC3_S	D2(mm)	6.23	3.41	3.41	6.23

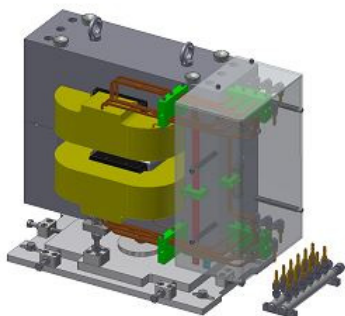

Figure 4: 3D modelling of Dipole Magnet D1.

The quadrupole magnets are classified into 11 kinds according to the aperture diameter, the effective length and the maximum gradient. Quadrupole Q11 and Q11 skew type are installed the bunch compressor. The specification of quadrupole Q11 is shown in the table 3 and Figure 5.

MECHANICAL DESIGN OF SUPPORT

The BC support structure consists of three structural steel tables with 30 mm thick aluminum top plates. The moving table top plate house two sets of linear motion guide rails, each with a roller bearing cart, on which an aluminum sliding main plate is mounted. The main plate supports the two central dipoles and an adjustable aluminum plate. This plate carries the DM2, DM3 dipole magnet, and the BPM mounted on support independently adjustable. The dipole movements are controlled by means of a transverse support table for dipoles DM2 and DM3. The table travel on a pair of linear rails each with two linear guide blocks.

Table 3: The Specification of Q11 Magnet

Aperture Diameter [mm]	44
Max. Field Gradient [T/m]	10
Effective Magnetic Length [mm]	100
Core Length [mm]	80
Current [A]	27.26
Power [W]	108.79
Inductance [H]	0.043

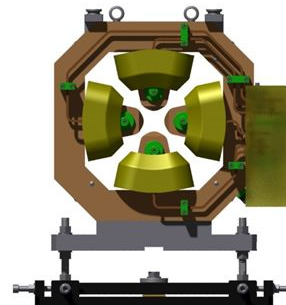

Figure 5: 3D modelling of Quad. Magnet Q11.

Figure 6 shows the component of the moving support system which is composed of basic support, moving table, sliding table, positioner and servo motor [2][3]. The mechanical parameters of the BC2 support systems are summarized in Table 4. The 406XR Positioner is capable of carrying relatively high loads up to a distance of 500 mm. Its quick and accurate positioning capability can be attributed to a high strength extruded housing, square rail ball bearing system, and precision ground ballscrew drive. It is equipped with 5mm lead ballscrew, linear encoder, electromagnetic break and limits switch.

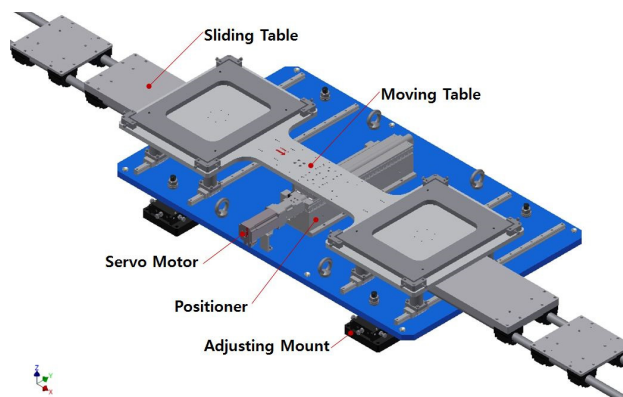

Figure 6: Component of moving support.

Table 4: Parameters of the BC2 Moving Support

Description	Moving Support
Dimension of Support[LxWxH][m ³]	5.0 x 1.3 x 0.53
Static torque of Servo Motor[Nm]	8.2
Working range of Positioner[mm]	500
Gear ratio	10:1
Resolution of Linear Encoder[μm]	0.5
Limit Switch & Hard Stopper	

CONTROL SYSTEM

The motor is controlled with a PC running *Twincat* PLC, a software by *Beckhoff* that will be used in PAL-XFEL. The software has been coded in Structured Text, following the IEC 61131-3 standard. It is driven by a single servo motor. Also has a one Incremental linear encoder, the two contact sensor. It is simple moving because of one axis drive. The length of the actuator has three types. 500mm 2sets, 600mm 1set, 700mm 1set. Controller is used the Beckhoff PLC C6920 can be installed the EPICS ioc.

VACUUM CHAMBER DESIGN

On the basic design of LCLS Bunch compressor vacuum chamber, we implemented some modification, fabricated and tested [4][5][6]. Bellows at each side of the bending magnet are installed to respond the bending angle for vacuum chamber. The four dipole magnet chambers, also drift vacuum chamber, are made from extruded 6063-T5 aluminum alloy, chosen for its high mechanical accuracy, better electrical conductivity, high strength and superior weldability and is suitable for use as a vacuum chamber material. Aluminum alloys allow easy extrusion of complicated cross sections using porthole dies, and the Al-Mg-Si alloy provides superior performance in extrusion. So relative permeability (μ_r) is under 1.03.

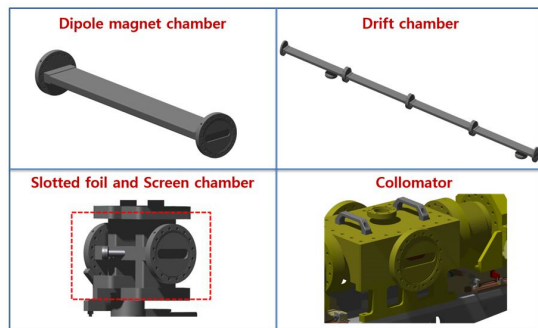

Figure 7: 3D modelling of unified beam chamber.

Figure 7 shows the dipole magnet chamber, slotted foil and screen chamber, collimator and the drift vacuum chamber. All chambers are approximately 800 mm long with internal 100 mm x 25 mm rectangular cross section. In order to reduce the deformation of the chamber, edge of cross section has rounded with 10R. Because it becomes the wall thickness is no more than 2 mm. An internal surface roughness of 150 nm was achieved with chemical treatment. The flange of the aluminum chamber is generally made of bi-metal method, especially friction welding which welded to the aluminum and stainless steel. Another method is that TiC coating on aluminum flange for high hardness. PAL-XFEL bunch compressor is adopted both methods. No detectable leak ($< 1 \times 10^{-10}$ mbar ℓ/s) is permitted for each components. We designed under 1×10^{-7} mbar after 48hr pumping. For maintained vacuum performance, we installed four sputter ion pumps

(SIP) for 60 ℓ/s with RF pumping slits. Figure 8 shows the design of the RF shielded chamber. The diagnostic section, between DM2 and DM3, consists of BPM, Slotted foil and Screen monitor. Two sputter ion pumps near diagnostic instrument to reduce pressure rise induced by collimator, slotted foil and screen monitor. One cold cathode gauge is placed to measure pressure at collimator. To reduce wakefield effect and energy loss, we designed unified beam chamber dimension and RF shielded chamber such as dipole magnet chamber.

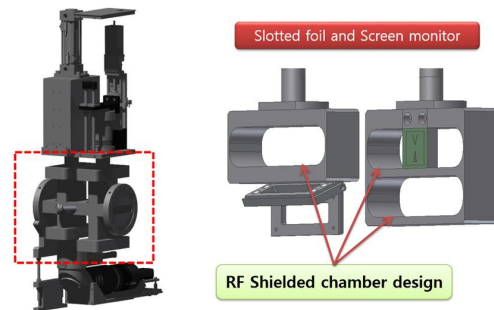

Figure 8: Design of the RF shielded chamber.

SUMMARY

In this report, the status of the PAL-XFEL bunch compressor system is briefly described. Three bunch compressor lattices for PAL XFEL are designed so as to minimize emittance growth due to CSR and mitigate microbunching instability. The support system has been successfully fabricated, assembled and load tested.

REFERENCES

- [1] H.S. Kang, J.H. Han, T.H. Kang, I. S. Ko, "Start to end simulation of three bunch compressor lattice for PAL-XFEL", IPAC2012, New Orleans, USA.
- [2] E. Rotela, S. Sharma, A. Barcikowski, and J. Biggs "Mechanical Design of a Flexible Bunch Compressor for APS LINAC" APS, ANL.
- [3] D. Lacivita, G. Lanfranco, G. Pangon, D. Zangrando, C. Belliero, M. Canetti and F. Gangini, "FERMI@ELETTRA bunch compressor chicane mechanical design" Diamond Light Source Proceedings, Vol 1, e19, page 1 of 4 MEDSI-6 2010.
- [4] D. La Civita et al., "FERMI@ELETTRA bunch compressor chicane mechanical design", Diamond Light Source Proceedings, Vol 1, e19 (2010).
- [5] Gian Luca Orlandi et al., "Bunch Compressor Transverse Profile Monitors of the SwissFEL Injector Test Facility", IBIC2012, Tsukuba, Japan.
- [6] "LCLS CDR", SLAC-R-593, April 2002.