

FUTURE OF HIGH INTENSITY ACCELERATORS IN NUCLEAR ENERGY

S.O.Schriber, J.S.Fraser and P.R.Tunnicliffe

Atomic Energy of Canada Limited
Physics Division, Chalk River Nuclear Laboratories
Chalk River, Ontario, Canada KOJ 1J0

Nuclear Power and Fuel Supply

The world's resources of fissionable elements, uranium and thorium, recoverable at acceptable cost, are sufficient to meet foreseeable energy needs for many centuries^{/1/}. To assure a secure energy future all of the fuel must be burnt in one or more of the so-called breeding fuel cycles as exemplified in a Fast Breeder Reactor using the ^{238}U - ^{239}Pu fuel cycle. Thorium can also be burned by using a ^{232}Th - ^{233}U fuel cycle^{/2,3/}. These cycles rely on converting fertile isotopes ^{238}U and ^{232}Th to corresponding fissile isotopes by capture of surplus neutrons not needed to maintain the chain reaction. In the energetic neutron spectrum of a fast reactor more than one surplus neutron per fission is generally available and consequently, fissile fuel supply can be replenished more rapidly than it is burned - the reactor is said to "breed". This surplus fuel is important because it enables additional power reactors to be added to the energy system - it provides the "inventory" to start these reactors and to overcome the inevitable hold-up in the fuel recycle process.

A stock of fissile material is necessary for the initial inventory of a Fast Breeder Reactor. Natural uranium can be mined and fissile ^{235}U can be separated from it or it can be converted to ^{239}Pu in thermal "converter" reactors. Unfortunately the world's uranium supply at acceptable cost for initial inventory purposes is limited, perhaps a few million tonnes. Its availability during the next 50 years will be crucial if nuclear energy is to replace exhausted petroleum supplies because even the most optimistic do not foresee the present generation of Fast Breeder Reactors being developed for commercial application as capable of providing inventory for the estimated expansion rate.

The heavy-water moderated thermal reactor as typified by the well proven^{/4/} CANDU (Canadian Deuterium Uranium) system is a "near-breeder" because it uses surplus neutrons efficiently. Advanced fuel cycle studies^{/3,5,6/} for CANDU reactors have shown that development of a new reactor design is unnecessary. Presently the CANDU system, which has reached industrial maturity, operates on a once-through natural-uranium fuel cycle burning ~ 1% of the heavy element content. If spent fuel is processed after a moderate burn up to remove fission product poisons and refabricated, it can be operated on a ^{232}Th - ^{233}U fuel cycle which is self sustaining; longer residence time in the reactor requires supplemental make-up of fissile material to maintain operation.

Figure 1^{/7/} illustrates the consequences of a limited uranium supply. To exploit our uranium supply, presently thought to be 3×10^5 tonnes assured in

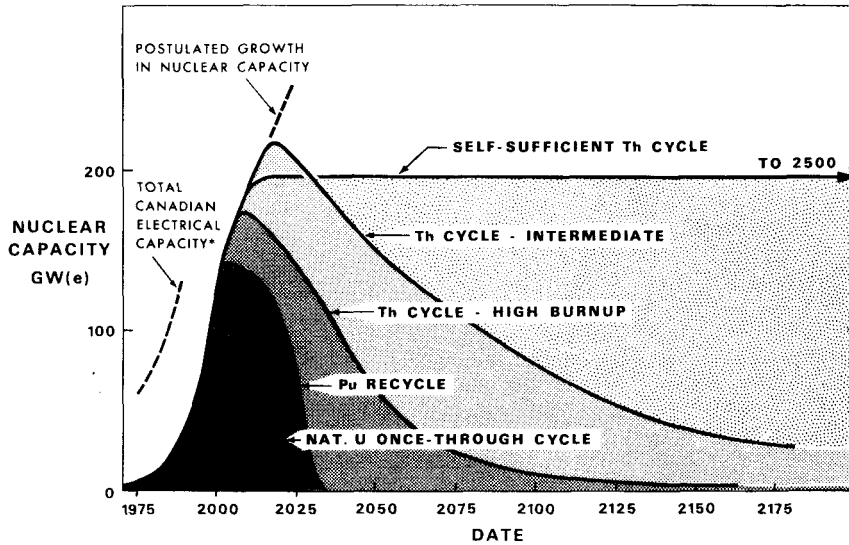

Fig. 1. Nuclear capacity from 3×10^5 tonnes uranium for various CANDU fuel cycles. Characteristics were determined assuming 1 year out-reactor delay for cooling, reprocessing, fabrication and holdup. Fuel burn-up (MWd/kg He) and the total energy produced (GWe-a) for the various cycles are: natural U - 7.5 and 1800, Pu recycling - 18 and 3500, Th - high burn-up (0.88 conversion ratio) - 37.4 and 6900, Th - intermediate (0.96 conversion ratio) - 19.5 and 17000, self-sufficient Th (1.0 conversion ratio) - 10.0 and 79000 (limited by Th supply assumed equal to U supply).

Canada, the figure shows how plutonium extracted from spent uranium fuel can be used to start up new reactors fueled on more plentiful thorium. For the self-sustaining case, a fuel residence time of not much greater than a year is needed; to obtain an appreciable breeding gain however is not feasible. Thus the nuclear energy supply capacity can only be built up to a fixed limit, in this case about 200 GWe capacity, (if more uranium is discovered the limit increases) which can be maintained for many centuries but is of inadequate capacity for long term needs. An accelerator-based Spallation Breeder provides an option for increasing nuclear capacity; such a device could provide fissile inventory generated either from depleted uranium or thorium stocks allowing increased thorium fueled reactor capacity to be built. A subsidiary purpose could be to support a non-self-sustaining fuel cycle, should increased capacity not be needed, if the net power cost were reduced.

Interest is also growing in possible application of the Spallation Breeder to more diversion-proof fuel cycles. Its potential for substantially increasing energy available from existing uranium supplies without reprocessing, or by using "denatured-fuel" cycles, is being studied by several laboratories^{7/8/}.

The availability of fissile material from natural uranium may place serious limitations on the long term growth and sustained yield of nuclear power. The ability of the accelerator-based Spallation Breeder to stretch uranium resources and provide fissile inventory may be the determinant factor in its deployment.

Spallation Breeding

Neutrons can be considered the essential ingredient in both establishing and maintaining a nuclear power system based on heavy-element fission. ^{235}U may be considered a neutron source that can be acquired by mining natural uranium and separating the ^{235}U . Two energetically plausible alternatives for the production of neutrons are:

- a) a DD- or DT-fueled fusion system not necessarily achieving energy breakeven

and b) accelerator-based production via the spallation process.

At present the latter seems the only one sufficiently close to industrial practicality and is the subject of this paper; fusion-fission systems have been discussed elsewhere^{/9/}.

The idea of "breeding" fissile material using high power accelerators and the spallation process is not new. In 1948, Goeckerman and Perlman^{/10/} observed that fission of bismuth by bombardment with 190 MeV deuterons was accompanied by the evaporation of 12 neutrons. O'Connor and Seaborg^{/11/} later the same year observed a similar phenomenon with uranium bombarded by 380 MeV α particles. The copious accelerator-based neutron production from the spallation reaction began to be exploited soon afterwards in the MTA program^{/12/} at the Livermore Radiation Laboratory in the USA with the objective of producing ^{239}Pu and ^{233}U in commercially useful quantities. The project was stopped in 1952 not because it was unpromising but by the discovery of high-grade uranium ores in the Colorado plateau. About the same time W.B. Lewis^{/13/}, at the Chalk River Nuclear Laboratories in Canada, independently recognized the significance of the large neutron yield from heavy elements excited to high energies in the breeding of fissile material, especially from ^{232}Th . This led to a Canadian experimental study^{/14/} of neutron yields from a variety of targets using cosmic ray protons. Our Intense Neutron Generator study^{/15/} was based on the large spallation neutron yield from lead and bismuth.

In a spallation breeder, a beam of protons or deuterons bombards a target to produce neutrons which in turn are captured by ^{238}U to form ^{239}Pu or by ^{232}Th to form ^{233}U . The production rate of neutrons and therefore of fissile material by capture in the fertile material increases with bombarding particle energy. It has been estimated^{/16/} that a 1 GeV proton could produce 50 neutrons and up to 4 GeV of heat in a sufficiently large target containing an appropriate uranium assembly including coolant and structural materials.

Figure 2 shows relative neutron capture rates in the ^{238}U component of a natural uranium target 120 cm in diameter by 90 cm long with the beam incident on an axial indentation 20 cm deep as calculated by Barashenkov et al^{/17/}. The curves are normalized to unity for protons at 1 GeV. Below 1 GeV, deuterons give a higher neutron yield per particle^{/17,18/} but this margin over protons diminishes to about 5% at 2 GeV. Yields for thorium are estimated to be lower^{/19/}.

Activation of the accelerating structure and surrounding components by spilt beam in the low energy portion is more severe with deuterons than with protons. Furthermore, the space-charge limit is about four times higher for protons than for deuterons of the same energy^{/20/}. Because the marginal gain to be had from deuteron beams is offset by increased structure activation and by a lower space-charge limit, protons of between 1 and 2 GeV are preferred for the spallation breeder.

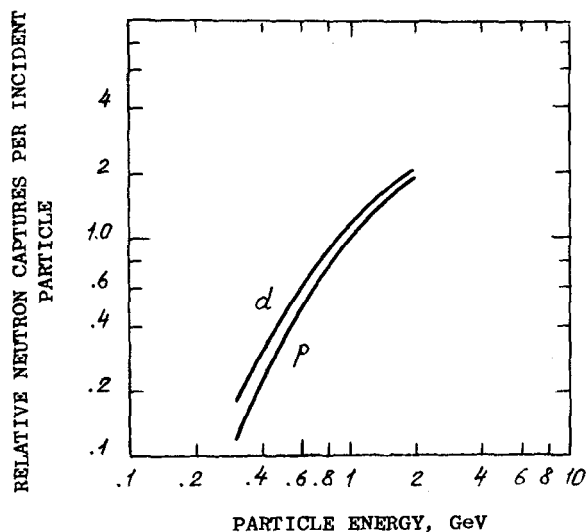

Fig. 2. The calculated relative neutron capture rate in the ^{238}U component of a large block ($\sim 1 \text{ m}^3$) of natural uranium bombarded by deuterons (d) and protons (p) normalized to unity for 1 GeV protons.

Nearly every neutron produced yields one fissile atom; thus 300 mA of 1 GeV protons on uranium could yield ~ 1 tonne/year of fissile material - sufficient to provide fuel inventory for ~ 0.25 GWe/year of increased capacity or topping enrichment for ~ 10 GWe of reactors with a conversion ratio of 0.93. One accelerator would supply fuel for a substantial electrical utility network.

Because the system will need little or no external energy supply it will produce one gram of fissile material for about 1.3 grams of fertile material consumed. By contrast, a uranium separation plant or a converter reactor would use ~ 200 g per gram of fissile material produced.

For the remainder of this paper we consider an accelerator-target system with 300 MW proton beam power and self sustaining in energy as a suitable design objective.

Accelerator Choice

Parametric studies discussed later have shown that spallation breeding costs become asymptotic for installations in which the fissile production rate exceeds 3 kg/day. Calculations, supported by experiments^{21/} predict that a 300 mA average, 1 GeV proton beam directed at a large natural uranium target will produce ^{239}Pu at the required rate.

Pulsed acceleration schemes such as the linear induction accelerator or synchrotron and some varieties of collective-effect accelerators are unlikely to be used unless they can produce high peak currents at high repetition rates. A sector-focused cyclotron with continuous injection from a 50 MeV proton linac has been proposed by the Dubna group; in a recent monograph, Banchev et al^{22/} proposed a large separated-magnet 8-sector cyclotron to produce a circulating beam of 100 mA at 900 MeV. Beam spill in the cyclotron would lead to more serious activation problems than an equivalent spill rate distributed along a long linac. Thus it may be difficult to limit radiation fields close to a cyclotron to a level allowing occasional access for maintenance without elaborate, portable shielding and/or remote handling. Other potential cyclotron problems that need investigation are the effect on beam behaviour of the heavy beam loading in the resonant accelerating cavities and the high concentration of rf power.

A superconducting linear accelerator with small structure power dissipation offers no advantage and many disadvantages when rf power requirements are dominated by the beam power. The modern room-temperature high shunt impedance linear accelerator listed in Table 1 is a sufficiently well developed technology that can provide a practical engineering solution within the time scale needed, ~ 30 years.

Table 1

Accelerator Characteristics for a Spallation Breeder

Particle	Protons
Energy	1 - 2 GeV
Beam Power	> 300 MW
Duty Factor	100%
Capacity Factor	~ 90%
Radiation Field from Induced Activation	< 100 mrem/h (1 mGy/h)

Figure 3 shows a schematic of a possible concept for the accelerator breeder system; by no means an optimized design. A relatively low energy injector feeds an alternating-phase focusing section. This is followed by an Alvarez drift tube section and a coupled cavity standing wave section.

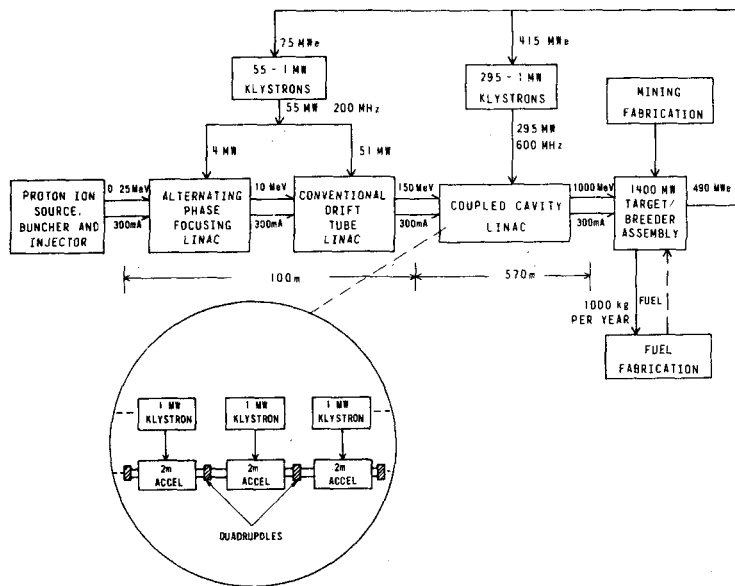

Fig. 3 Schematic of Accelerator Breeder

Economics

Cost estimates are uncertain because of the limited development of the necessary technology, lack of detailed target design concepts and unstable and differing financial conditions. However an attempt will be made to demonstrate that the economic prospects for accelerator breeding are not unreasonable. The system is considered in four major parts and costs are given in 1980 \$'s.

(a) Target-Electrical Generating System

The target would, in all probability, resemble some type of fast reactor; minimum amounts of low-Z material are necessary to maximize product yield. The ~ 1400 MW thermal power generated in the target is sufficiently large and of sufficiently high grade, that it would be economical to recover it as electrical power and would be sufficient to operate the accelerator (not a necessary condition but within technological reach). The cost of the target can to a first approximation be estimated as if it were a reactor, $\$1000/\text{kWe}^{23/}$. Converting thermal power to electricity at 35% efficiency would provide 490 MWe at a capital cost of about $\$500$ M.

(b) Rf Power

300 MW of rf power is required to provide beam power and about 50 MW to excite the accelerating structure. A recent cost estimate^{24/} of a 9 MW cw rf system using 18 klystrons was $\sim \$500/\text{kW}$ (1975 \$'s). Allowing for scale factors, optimization of dc power supplies and inflation, and using current estimates, a 350 MW system might cost $\sim \$570/\text{kW}$ or $\$200$ M.

(c) Accelerating Structure, Shielded Tunnel, etc.

From earlier estimates^{25/} and allowing for improvements in design, the accelerator structure with shielding and services would cost about $\$50$ M.

(d) Other Items Including Injector and Beam Transport System

Within the uncertainties of estimating the previous items this is considered negligible.

Allowing an annual interest and depreciation charge of 10% over a 30 year period on the total $\$750$ M capital investment and assuming that the operating and maintenance charges are about 10% of the capital charge rate, the estimated unit cost of production of fissile material in a plant with 1 tonne annual capacity is $\sim \$83/\text{g}$. The cost of chemically separating the fissile material (2% enrichment) from the fuel could raise this figure to $\$100/\text{g}$. The relative contributions to this cost are:

a) Target capital	50%
b) Rf capital	20%
c) Linac capital	5%
d) Operation and Maintenance	8%
e) Reprocessing	17%

Until accelerator and especially target concepts are developed further, more accurate cost estimates cannot be made. But it is clear that target and rf equipment costs are dominant and that efficient use of ac power and efficient target designs will be important.

Accelerator produced fissile material at $\$100/\text{g}$ would be competitive with reprocessing charges of recovering plutonium from spent CANDU reactor fuel if

costs were \$300/kg of heavy element (plutonium content is $\sim 0.3\%$).

Estimates of ^{235}U enrichment costs published in 1976^{/26/} indicate a separative work unit cost of \$150/kg. At 93% concentration and at "0.3% tails" (i.e. 1 kg natural uranium yields 4 g ^{235}U), the total cost per fissile gram is given by $0.22 (\$150/\text{kg}) + 0.29 (\$/\text{kg cost for } \text{U}_3\text{O}_8)$. Enrichment costs would be competitive to \$100/g spallation breeding when U_3O_8 prices are \$230/kg.

While these comparisons are no more than guidelines, they indicate that accelerator breeding costs may be competitive by the year 2000 - U_3O_8 prices are rising from the present \$90/kg and severe shortages can be foreseen in the near future.

Accelerator Breeder

Foundations of the necessary accelerator technology have been laid in the design and construction of the Los Alamos Meson Physics Facility (800 MeV, 20 mA, 12% duty factor)^{/27/}. That concept provided the basis for the study which led to the final version of the proposed Intense Neutron Generator accelerator (1 GeV, 65 mA, 100% duty factor) in 1967^{/25/}. In addition pulsed currents of > 300 mA for 5 μs have been achieved by the Brookhaven, CERN and Fermilab synchrotron injectors^{/8/}, and rf power tubes of MW capacity have been built and efficiencies of 75% achieved^{/28,29/}.

Because the accelerator will be designed close to the space-charge limit, 100% duty factor operation is essential. Avoiding pulsed operation has other important advantages including a major effect on the cost of the radiofrequency supply and simplification of regulating systems.

Current capability, efficiency and costs are not the only factors that must be considered; reliability and maintainability are also important factors in selection of machine design concepts and parameters discussed below.

(a) Rf Power

As already noted the radiofrequency power supplies will dominate costs and efficiency of the accelerator. Three technologies are available; gridded tubes, crossed field devices and linear beam devices. While all three are potentially capable of operating within plausible frequency and power requirements, our experience, like that at LAMPF, indicates that the klystron is likely the only satisfactory device for a multi-tank accelerator. Gridded tubes have low gain at high frequencies and the rf amplifier chain tends to be complicated^{/30/} and expensive, costing about \$1/watt^{/31/}. Crossed field devices, operating as amplifiers, have been capable of operating at high efficiencies and with potential up to 500 kW cw with good efficiencies^{/32/}. However these devices, have low gain, are difficult to control and have some unpleasant application problems.

High power cw klystrons with good efficiency have been built and operated over a wide frequency range^{/29,33/}. Because the gain is high, typically 50 db, the device can be driven with cheap low power sources and amplitude and phase control is straightforward^{/34/}. Frequencies between 200 MHz and 3 GHz seem feasible but klystrons would probably become unmanageably large both in physical size and in rating at much lower frequencies.

The efficiency of each step in the power cycle - ac to dc, dc to rf and rf to beam must be maximized and the cost minimized. (The ING study^{/25/} showed that ac-to-dc conversion was optimized in a module size of 18 MW.) Application of modern accelerator physics and computational techniques to klystron design should raise efficiencies above 75%. New devices with high efficiency and controllability

such as the "gyrotron" being developed in the USSR may reduce costs and increase efficiency.

The allowable beam diameter in the accelerator is inversely proportional to frequency so that space charge limitations favour low frequencies. This is exemplified by recent proposals for CTR materials testing facilities which use 50 MHz/^{31/}; chosen to hold activation caused by beam spill within acceptable limits. A breeder accelerator would exploit several design features to reduce effects of beam spill and allow use of a more economical higher frequency. These include increasing the admittance by using a low injection energy with an alternating phase focusing linac, improved focusing, and choosing the accelerator material to reduce activation. A 200-600 MHz operating combination is probably optimal with the frequency transition occurring \sim 150 MeV.

Currently, a 1 to 2 MW klystron is probably an economic size. Voekler/^{35/} has proposed the use of an rf manifold to parallel the outputs of several power amplifiers and to distribute the combined power to several structure modules or tanks which have low beam loading. This concept is receiving attention in the PIGMI program/^{36/} at Los Alamos associated with multiple feeds to a disc and washer structure/^{37,38/}. For a heavily beam-loaded linac, as proposed for the spallation breeder, the manifold concept may not be appropriate because of problems associated with isolating a failed unit. With an energy gradient of 1.5 MeV/m and a beam current of 300 mA, the linear energy feed density is 0.45 MW/m - one present day klystron per metre. With such a high power density, the fractional energy change caused by the failure of a single unit could probably be tolerated by the accelerator except near the "front end". Figure 3 shows a design concept based on 2 m long modules each fed by a 1 MW klystron. This arrangement isolates each module in terms of rf, making maintenance or replacement of an accelerating module and detuning or isolating an accelerating module in the event of a klystron failure, easier. Fifty-five 1 MW klystrons are required for the 200 MHz accelerating section while 295-1 MW klystrons are required for the 600 MHz accelerating section. Because of the large number of tubes involved, an in-house facility would be necessary for manufacture and repair of klystrons.

(b) Ion Source and Injector

Low beam spill and high capture efficiency require a low emittance injector. Emittance control in the dc accelerating, buncher and injector beam line will present the major problems. Work has been underway for several years at Chalk River/^{39/} on the development of dc ion sources and accelerating columns. Work at ORNL/^{40/} has shown that 100 mA beams can be obtained reliably but of unknown emittance.

Provided sufficient current can be captured, beam spill allowable near injection is primarily determined by heat removal problems. However, use of a multi-cavity buncher system and possibly a chopper, to remove uncaptured beam, may be desirable. Beam emittance at a few MeV will influence beam spill in the higher energy parts of the machine. Emittance "filtration"/^{41/} must not discard too large a fraction of the current or operation at higher frequencies will be defeated. A detailed understanding of space-charge induced emittance growth in the injector, buncher system and during initial rf acceleration, which conforms to observed behaviour, is essential.

(c) Accelerating Structures

The rf frequency of the drift-tube linac should be higher than 50 MHz/^{20,42/}, perhaps 150-200 MHz where high efficiency klystrons can be used and where the frequency ratio between the drift-tube and coupled-cavity structures can be as low as 3. Recent work/^{43/} at Los Alamos has suggested that the use of

alternating phase focusing should permit an injector voltage as low as 200 kV and an accelerating structure frequency of 150 MHz for a steady current of 300 mA.

Two experiments at the Chalk River Nuclear Laboratories^{/44,45/} have shown that a 268 MHz drift-tube structure and a 805 MHz side-coupled structure, can be operated at 100% duty factor rf fields with no difficulty. Sufficient improvement has been made in heat transfer to permit operation at 20 times the average structure power density of the LAMPF structure operated at 6% duty factor. The coupled-cavity structure has been operated up to 50% beam loading with electrons and rf accelerating fields were controlled^{/34/} to within 0.2% in amplitude and 1° in phase. A small but finite beam-induced phase tilt along the structure was observed. At 90% beam loading, phase tilt would have to be considered in long structure design.

The choice of accelerating gradient will depend on relative values for length-dependent costs and incremental unit costs for rf power. Improved performance of simpler coupled-cavity standing-wave structures with on-axis couplers^{/46/} promise reduction in length-dependent costs but there will still be economic pressure to use gradients higher than 1.5 MeV/m. An improved on-axis coupled cavity with a 10% coupling constant could be used for 2 m modules. Module spacing is such that quadrupoles can be appropriately located. The disc and washer structure with its 40% coupling constant shows promise as an alternative for the coupled-cavity section.

The choice of output energy, current and gradient is not only dependent on unit costs of accelerator components but also on neutron yield in the target and on its cost. A computer optimization code has been used to give results quickly for different scenarios. Presently the code only ascribes "global" length dependent costs to the accelerator but more sophistication to account for transitions in accelerating structure and other cost factors will be added. Figure 4 illustrates the output for one particular set of assumptions for different fissile production rates. The results indicate the advantages of scale and, on the larger scale, the relative independence of accelerator output energy. As there will undoubtedly be a cost factor associated with overcoming space charge effects the optimum energy may move towards 2 GeV. Also shown as a function of energy is the proton beam current required to produce 3 kg/d of fissile material.

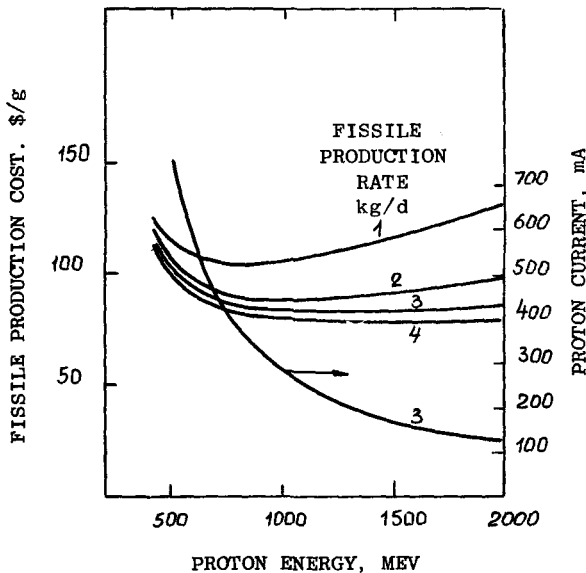

Fig. 4 Calculated unit fissile product costs for production rates 1 to 4 kg per day vs. proton energy. The principal assumptions are: electrical power costs, 10 m\$/kWh; target capital, \$1000/kWe; interest and depreciation, 10% per year; rf equipment capital \$570/kW; accelerator length cost, \$50,000/m; maximum peak accelerating field, 1.5 MeV/m, averaged over the accelerator length. Proton beam current as a function of energy to produce 3 kg/d is shown referenced to the right hand ordinate.

Structure development will continue not only to improve manufacturing procedures but also to improve beam dynamics, for example, by the incorporation of electromagnetic focusing within coupled cavity structures. The PIGMI program^{/36,43/} at Los Alamos promises to produce important innovations in structure design especially suitable for the low energy section of the accelerator; such improvements will improve reliability and operation without affecting overall costs appreciably.

(d) Beam Spill, Reliability and Maintainability

The amount of beam spill that can be tolerated is determined by two effects, heating and activation. Except for the first few drift tube cells, the latter is the most important consideration. Below a few MeV the nuclear activation that can be induced by protons can be minimized by materials choice. Above this energy many radioactive nuclides can be produced and, as the energy increases, spallation activation becomes the important factor. To a first approximation activation will be proportional to the power of the spilt beam but it will also depend on the materials involved - lower mass nuclides are generally least active, at least during the first 10^3 - 10^4 hours after irradiation^{/25/}.

Brookhaven, CERN and Fermilab have found that with careful alignment and with extensive use of beam loss monitors along the injector structure, beam spill after the first few drift tubes can be kept to about 1 part in 10^4 of the accelerated beam. If this spill can be maintained in the low-energy drift-tube section with 100% duty factor operation and reduced to 1 part in 10^5 in the higher energy coupled-cavity section, it should be possible to limit radiation fields near the structure a few hours after a shutdown to less than 100 mrem/h (1 mGy/h). This radiation field is low enough to allow "hand-on" maintenance. Experience at Los Alamos^{/47/} has shown that proper alignment of the linear accelerator is crucial in reducing activation by spilt beam. A large effort is underway at LAMPF^{/8/} to understand beam halo growth at intermediate energies.

If any component that affects the transport of the beam failed, a fast-shutdown system would be needed to limit spilt energy to the order of magnitude of the stored beam energy. The stored energy of a 300 mA beam in flight through a 1 GeV linear accelerator is about 1 kJ. A localized spill of this much energy, roughly equivalent to the allowable distributed beam spill during one second, would be tolerable.

Simplicity of equipment located in the machine tunnel, use of passive components such as permanent magnet quadrupoles and radiation-hardened components will minimize maintenance problems. Electrical and mechanical tolerances must be carefully determined and met and, if possible, provision made for continued operation with faults.

(e) Regulation

There is a need to develop a scheme to reduce or cope with power reflected to the rf source during run-up from zero to 90% beam loading. This could take the form of a motor-driven variable coupler to effect a dynamic match, or an auxiliary microwave network, or a specially designed klystron capable of tolerating a bad mismatch. Characteristics of the target-reactor will undoubtedly require that beam current be run up slowly over a period of many minutes. The accelerator control system including beam transport, structure resonance, field amplitude and phase control, must be capable of accurately tracking the slow run-up conditions as well as any fast disturbances.

(f) Target

The target/breeding assembly will have many features of the Fast Breeder Reactor and benefit greatly from the latter's technology. Preliminary neutronic calculations have been done for the assembly by Chalk River^{/48/}, ORNL^{/49/}, BNL^{/50/} and LASL^{/51/}. These include basic cascade and multigroup neutron transport calculations. Only spot verification measurements have been made on neutron production, absorption and leakage for targets of simple cylindrical geometry. A start has been made on measurements with more complex assemblies at TRIUMF^{/52/}.

Realistic design concepts which take into account heat transport, non-uniformity of power densities, fuel management, radiation damage and materials compatibility need to be developed before accurate prediction of yields and ultimate fate of the neutrons can be made. The concept receiving some attention at CRNL consists of a liquid target such as lead-bismuth surrounded by a uranium or thorium blanket.

Conclusions

The prospect of high power accelerators for spallation breeding of fissile materials, to extend fissionable fuel resources into the indefinite future, has been enhanced in recent years by developments at several research accelerator installations and by experiments with low power 100% duty factor linacs. It appears likely that beam spill can be controlled sufficiently to allow hands-on maintenance. The linear accelerator technology appears to be well developed and could be brought to industrial fruition within a few decades, the time scale required.

Nevertheless, considerable development remains to be done, especially in injection, low energy beam handling, initial acceleration and emittance control of the beam. Methods and devices need to be developed for handling large amounts of rf power under a wide range of operating conditions. High efficiency, reliable and cheap MW klystrons in the 200-600 MHz range need development; none of these problems seem to need new technological developments - effective use of existing techniques will produce the desired results. Much work remains to be done on the development of the target blanket assembly.

The cost of fissile material produced by this route will probably approach \$100/g (1980 \$'s). While this cost is not competitive now, shortage of uranium will likely alter the situation within the time scale needed for achieving industrial capacity. Indeed, such fissile material may prove crucial in providing inventory for expansion of nuclear power at the rate necessary during the next 50 years.

References

1. A.J. Mooradian and O.J.C. Runnalls, Atomic Energy of Canada Limited, Report No. AECL-4916 (1974).
2. C.H. Millar, CRNL, private communication.
3. E. Critoph, Atomic Energy of Canada Limited, Report No. AECL-5705 (1977), Paper IAEA-CN-36/177, IAEA Int. Conf. on Nuclear Power and its Fuel Cycle, Salzburg, 1977.
4. G.R. Fanjoy and A.S. Bain, Atomic Energy of Canada Limited, Report No. AECL-5711 (1977), Paper IAEA-CN-36/184, *ibid*.
5. J.S. Foster and E. Critoph, *Ann. Nucl. Energy* 2, 11/12, 689 (1975).
6. J.S. Foster and E. Critoph, paper for the Conference on World Nuclear Energy, Washington, D.C., November 14-19, 1976, to be published.

7. J.S. Foster and S.H. Russell, Atomic Energy of Canada Limited, Report No. AECL-5707 (1977), Paper IAEA-CN-36/179, IAEA Int. Conf. on Nuclear Power and its Fuel Cycle, Salzburg, 1977.
8. Proc. of the ERDA Information Meeting on Accelerator Breeding, January 18-19, 1977, Brookhaven National Laboratory, Upton, L.I., to be published.
9. L.M. Lidsky, Nucl. Fusion 15, 151 (1975).
10. R.H. Goeckerman and I. Perlman, Phys. Rev. 73, 1127 (1948).
11. P.R. O'Connor and G.T. Seaborg, Phys. Rev. 74, 1189 (1948).
12. Livermore Research Laboratory Report No. LRL-102 (1954).
13. W.B. Lewis, Atomic Energy of Canada Limited, Report No. AECL-968 (1952).
14. M. Bercovitch, H. Carmichael, G.C. Hanna and E.P. Hincks, Phys. Rev. 119, 412 (1960).
15. The AECL Study for an Intense Neutron Generator, G.A. Bartholomew and P.R. Tunnicliffe, eds., Atomic Energy of Canada Limited, Report No. AECL-2600, (1966).
16. P.R. Tunnicliffe, B.G. Chidley and J.S. Fraser, Proc. 1976 Prot. Lin. Accel. Conf., Atomic Energy of Canada Limited, Report No. AECL-5677, 36 (1976).
17. V.S. Barashenkov, V.D. Toneev and S.E. Chigrinov, Atomnaya Energiya [Sov. J. At. Energy] 37, 480 (1974).
18. D. West and E. Wood, Can. J. Phys. 49, 2061 (1971).
19. J.C.D. Milton and J.S. Fraser, Atomic Energy of Canada Limited, Report No. AECL-2259 (1965).
20. K. Batchelor, Proc. 1976 Prot. Lin. Accel. Conf., Atomic Energy of Canada Limited, Report No. AECL-5677, 160 (1976).
21. J.S. Fraser, R.E. Green, J.W. Hilborn, J.C.D. Milton, W.A. Gibson, E.E. Gross and A. Zucker, Phys. in Canada 21 (2), 17 (1965). See also Atomic Energy of Canada Limited, Report No. AECL-2600, p.VII-11 (1966).
22. V. Ts. Banchev, S.B. Vorozhtsov, V.P. Dimitrievski and N.L. Zaplatin, JINR P9-9848 (1976).
23. D.E. Anderson, 16th Int. Conf. of Can. Nucl. Assoc., Toronto, ISSN 0317-168X, 5, 12 (1976).
24. PEP Conceptual Design Report, Lawrence Berkeley Laboratory Report No. LBL-4288 (1976).
25. ING Status Report July 1967, T.G. Church, ed., Atomic Energy of Canada Limited, Report No. AECL-2750 (1967).
26. Nucleonics Week, 17 (53) (1976).
27. A Proposal for a High-Flux Meson Facility, Los Alamos Scientific Laboratory, September 1964, 358 (1964).
28. E.L. Lien, Proc. 8th Int. Conf. on Microwave & Optical Generation, 11 (1970).
29. R.H. Giebeler, J. Microwave Power 4, 79 (1969).
30. J.C. Brown and B.G. Chidley, Proc. 1976 Prot. Lin. Accel. Conf., Atomic Energy of Canada Limited, Report No. AECL-5677, 296 (1976).
31. See for example, P. Grand, ed., Brookhaven National Laboratory Report No. BNL-20159 (1975) and BNL-20840 (1976).
32. J.F. Skowron, W.C. Brown and G.H. McMaster, Microwave J. 7, (10), 65 (1974).
33. G.T. Conrad, Proc. 1975 Part. Accel. Conf., IEEE NS-22 (3), 1249 (1975).
34. J. McKeown, J.S. Fraser and G.E. McMichael, Proc. 1976 Prot. Lin. Accel. Conf., Atomic Energy of Canada Limited, Report No. AECL-5677, 291 (1976).
35. F. Voekler, Proc. 1963 Prot. Lin. Accel. Conf., TID-7619, 321 (1963).
36. E.A. Knapp and D.A. Swenson, Proc. 1976 Prot. Lin. Accel. Conf., Atomic Energy of Canada Limited, Report No. AECL-5677, 230 (1976).
37. V.G. Andreev et al., ibid, 269.
38. J.J. Manca, E.A. Knapp and D.A. Swenson, Proc. 1977 Part. Accel. Conf., IEEE NS-24 (3), to be published.
39. J. Ungrin, J.D. Hepburn, M.R. Shubaly, B.G. Chidley and J.H. Ormrod, Proc. 1976 Prot. Lin. Accel. Conf., Atomic Energy of Canada Limited, Report No. AECL-5677, 171 (1976).
40. O.B. Morgan, G.G. Kelley and R.C. Davis, Rev. Sci. Inst. 38, 467 (1967).
41. B.P. Murin and A.P. Fedotov, Atomnaya Energiya 38, 146 (1975).

42. J. Staples, D. Clark, A. Grunder, H. Lancaster, R. Main, F. Selph, L. Smith, F. Voelker and R. Yourd, Proc. 1976 Prot. Lin. Accel. Conf., Atomic Energy of Canada Limited, Report No. AECL-5677, 148 (1976).
43. D.A. Swenson, *ibid*, 234 (1976). See also D.A. Swenson and J.E. Stovall, Proc. 1977 Part. Accel. Conf., IEEE NS-24 (3), to be published.
44. J.S. Fraser, J. McKeown, G.E. McMichael and W.T. Diamond, Proc. 1976 Prot. Lin. Accel. Conf., Atomic Energy of Canada Limited, Report No. AECL-5677, 166 (1976).
45. B.G. Chidley, S.B. Hodge, J.C. Brown and J. Ungrin, Proc. 1972 Prot. Lin. Accel. Conf., LA-5115, 218 (1972).
46. S.O. Schriber, L.W. Funk and R.M. Hutcheon, Proc. 1976 Prot. Lin. Accel. Conf., Atomic Energy of Canada Limited, Report No. AECL-5677, 338 (1976).
47. D.C. Hagerman, *ibid*, 12 (1976).
48. P.M. Garvey, CRNL, private communication.
49. ABACS Study Group, ORNL/TM-5750 (1977).
50. Linear Accelerator Breeder, BNL-50592 (1976).
51. E.A. Knapp, LASL, private communication.
52. Progress Report, Physics Division, January 1 - March 31, 1975, Atomic Energy of Canada Limited, Report No. AECL-4916, 125 (1975).

ДИСКУССИЯ

И.М.Капчинский: Как оценивает докладчик время жизни конструкционных материалов при потерях на уровне 10^{-5} ?

S.O.Schriber: We hope that the accelerator will have a life-time of twenty or thirty years.

I.Enchevich: At first I would like to appreciate the efforts of the Chalk-River's group, which in long time period faces the energy problem one of the first order of importance for the future.

Concerning the choice of the linac type, from the point of view of low induced radioactivity, it seems, that it needs supplementary to be justified because if the separated orbit cyclotron is regarded as a winded linac, it is a linac without vertical walls, so, it can't be activated. Furthermore, low activated materials, like graphite, can't be applied in linacs because of the RF losses. Finally, the comparison of the working accelerators of the both types - SLN and LAMPF - doesn't indicate important advantages from this point of view for the linac during the start period. Adding here the difference in the size and price between them, it seems, that at least both types are competitive.

S.O.Schriber: You have horizontal walls where you have a half of the beam spill. The beam spill can be concentrated on the small area and there may be problems with handling of the active materials.

You will have the problems of getting in RF power of the order of hundreds MW in one area, rather than to be distributed.

L.Teng: From the economic point of view, it is quite clear that Linac is the optimal choice of accelerator type. The neutron production rate is approximately proportional to the power in the beam. Therefore one wants the most efficient accelerator in converting electric power to the beam power. Because of space constraints, the accelerating RF cavities in a circular machine are not as efficient as linac cavities. In addition, the magnets which bend the beam into circular orbit will necessary add to the capital and operating cost.

В.П.Джелепов: Имеются ли новые результаты по измерению размножения нейтронов на мишенях?

S.O.Schriber: The results, I believe, are published in one of the latest reports of Physics division of the Chalk-River.

С.П.Капица: Рассматривалось ли применение магнетронных усилителей, обладающих в некоторых случаях КПД 90%, для мощных ускорителей ?

S.O.Schriber: We have looked at the amplitrons and they have some very distinct problems.

А.П.Федотов: Проводились ли расчеты по динамике частиц для какого-то варианта начальной части ускорителя ?

S.O.Schriber: The calculations of the dynamics of the beginning part of the accelerator are based on some preliminary calculations done by D.Swenson in Los Alamos.

А.П.Федотов: Каковы Ваши планы на ближайшие 3-5 лет, включая работы по начальной части ускорителя с инжектором и работы по повышению КПД мощных генераторов?

S.O.Schriber: We have 3 MeV Linac which is fed from a 750 KeV Cockroft-Walton set and this structure will be used for measurements of the beam problems at the beginning of the accelerator. Next five years we would like to be involved in some calculations and in obtaining the experience in designing klystrons and we are interested in finding out some more information about the studies of the gyrotron.

S.J.Kapoor: Would you like to comment on the additional problems of radioactive waste disposal in this scheme of use of accelerator for breeding of fissionable fuel?

S.O.Schriber: Activity problems with the target breeder and fuel fabrication are going to be more serious than in accelerator structure.

Don Swenson: We at Los-Alamos are quite interested in the concept of the gyrotron for the high power, RF-power generation, and may undertake a study of this device in the next two years. We believe some combination of APF and Quadrupole lenses will allow injection at a lower energy to the benefit of the total operation. We are very interested in the DISK and washer structure for the coupled cavity portion of the design because of the very high cell-to-cell coupling making it very suitable for heavily beam loaded applications.

В.П.Джелепов: Имеется ли какая-либо согласованная программа между Чок-Ривером, Лос-Аламосом и другими по дальнейшему изучению проблем размножения нейтронов и моделированию мишеней ядерного бридинга?

S.O.Schriber: The target assembly that is presently being used at TRIUMF may turn out to be reasonable assembly to use in Los Alamos.

Don Swenson: We have plans in Los Alamos to make both: cross section measurement using the LAMPF accelerator and also mock-up of the target assembly as an alternate beam stop for LAMPF.

Ю.М.Адо: Что Вы можете сказать о преимуществе и недостатке применения дейтронов в электроядерном бридинге?

S.O.Schriber: At low energies deuterons are more efficient in producing neutrons than the protons, and for higher energies these differences are only about 5% and the reason in application of protons instead of deuterons is that the accelerator structure activation is much less and space charge limit is higher for the protons of the high energy.

А.А.Наумов: Мне представляется, что линейные ускорители более перспективны для решения этой задачи. Однако на данном этапе нельзя отказываться от использования кольцевых ускорителей. Поэтому очень желательно, чтобы оба направления развивались одновременно в разных лабораториях.