

RESONANCE CONTROL FOR FERMILAB'S PXIE RFQ*

D. Bowring[†], B. Chase, J. Czajkowski, J. Edelen, D. Nicklaus, J. Steimel,
T. Zuchnik, Fermilab, Batavia, IL, USA

A. Edelen, S. Biedron¹, S. Milton, Colorado State University, Ft. Collins, CO, USA

¹also at Faculty of Electrical Engineering, University of Ljubljana, Ljubljana, Slovenia

Abstract

The RFQ for Fermilab's PXIE test program is designed to accelerate a ≤ 10 mA H^- CW beam to 2.1 MeV. The RFQ has a four-vane design, with four modules brazed together for a total of 4.45 m in length. The RF power required is ≤ 130 kW at 162.5 MHz. A 3-kHz limit on the maximum allowable frequency error is imposed by the RF amplifiers. This frequency constraint must be managed entirely through differential cooling of the RFQ's vanes and outer body and associated material expansion. Simulations indicate that the body and vane coolant temperature should be controlled to within 0.1°C . We present the design of the cooling network and the resonant control algorithm for this structure, as well as results from operation.

INTRODUCTION

The Proton Improvement Plan II (PIP-II) is a potential upgrade to the Fermilab accelerator complex [1]. The PIP-II Injector Experiment (PXIE) is a test accelerator supporting this upgrade effort, shown conceptually in Figure 1 and consisting of an H^- ion source; low-energy beam transport (LEBT); a CW-capable RFQ; medium-energy beam transport (MEBT); superconducting half-wave and spoke resonators; high-energy beam transport (HEBT); and a beam dump [2, 3].

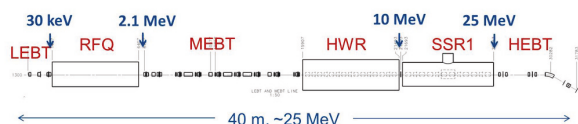

Figure 1: Layout of the PXIE beamline.

The RFQ is a 162.5 MHz, 4.45 m, four-vane structure, designed to accelerate a ≤ 10 mA beam – pulsed mode or CW – to 2.1 MeV. ≤ 130 kW power (CW or pulsed) is delivered from two 75 kW solid-state amplifiers, via two coupling loops [4]. Four modules were fabricated separately and then brazed together to form the final structure. Design and construction are discussed thoroughly in [5]. The RFQ was installed at Fermilab in the PXIE beamline in the Fall of 2015.

Of particular significance to this paper are the two channels and associated sub-circuits for cooling water, shown in Figure 2. These channels are gun-drilled through the copper cavity structure. By design, dynamic frequency tuning

*This manuscript has been authored by Fermi Research Alliance, LLC under Contract No. DE-AC02-07CH11359 with the U.S. Department of Energy, Office of Science, Office of High Energy Physics

[†] dbowring@fnal.gov

of the RFQ is accomplished via differential cooling (and the resultant differential expansion) of these circuits. A system of pumps, flow control valves, helical mixers, and manifolds circulates water at controllable temperature and flow rates through the vanes and walls, shown schematically in Figure 3. This system was designed specifically to accommodate the resonance control system through optimal placement of the various pumps and mixers to minimize loop delay, and through choice of components with appropriately fast response times and large operating ranges. Relevant details of the water system are shown in Table 1. Note that the vane and wall channels are coupled due to the shared warm return line to the cooling skid, pressure balancing effects, and thermal transfer between channels through the body of the RFQ.

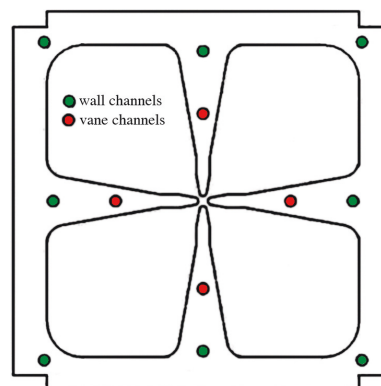

Figure 2: Cross section of the RFQ, showing channels for cooling water in the vanes (red) and body (green).

Table 1: Selected parameters of the PXIE RFQ water system. The parameter $\Delta f/T$ is addressed in depth below.

Parameter	Vane Circuit	Wall Circuit
Nominal heat load	29 kW	50 kW
Maximum heat load	38 kW	65 kW
Minimum flow rate	44 gpm	88 gpm
Nominal flow rate	65 gpm	136 gpm
Maximum flow rate	87 gpm	172 gpm
Nominal temp. rise	$\sim 1.4^\circ\text{C}$	$\sim 1.0^\circ\text{C}$
H ₂ O circulation time	$\lesssim 23$ s	$\lesssim 25$ s
$\Delta f/T$	-16.7 kHz/ $^\circ\text{C}$	+13.9 kHz/ $^\circ\text{C}$

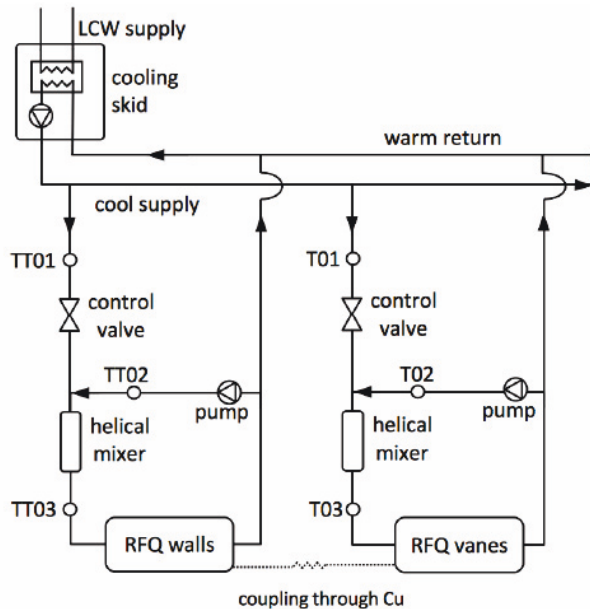

Figure 3: Simplified schematic of coolant water distribution for PXIE RFQ. Nodes marked T01, TT02, etc. indicate temperature sensors.

FREQUENCY CONTROL

Operational and hardware considerations impose the following requirements for resonance control: stable operation of the RF amplifiers requires ≤ 3 kHz frequency error; reflected power should be $< 20\%$ of input power; trip recovery duration should be double (and no more than $10\times$) the trip duration; and system equilibration at startup should last no longer than 30 minutes.

As stated above, dynamic tuning during operation is accomplished via differential cooling and control of water in the vane and wall circuits. Frequency control for RFQs at other laboratories is often handled in a similar way, though water temperature in the wall channel may be held constant while that of the vane channel is controlled [6, 7].

Frequency is naturally more sensitive to thermal fluctuations in the vane tips than in the cavity body. ANSYS simulations indicate a -16.7 kHz change in resonant frequency per $^{\circ}\text{C}$ temperature change in the vane circuits, a $+13.9$ kHz/ $^{\circ}\text{C}$ temperature change in the wall circuits, and a combined -2.8 kHz/ $^{\circ}\text{C}$ [8]. Low-power RF measurements during bead-pull analysis (without input couplers installed) give -2.7 kHz/ $^{\circ}\text{C}$. Together, this suggests that coolant temperature should be controlled to within 0.1°C . To illustrate the delays involved in controlling a structure with significant thermal inertia, the frequency response to a transient temperature change is shown in Figure 4.

Ultimately, these frequency and temperature stability requirements will be met via model-predictive control (MPC) [9]. This approach to the resonance control of the PXIE RFQ is discussed in more depth elsewhere in these proceed-

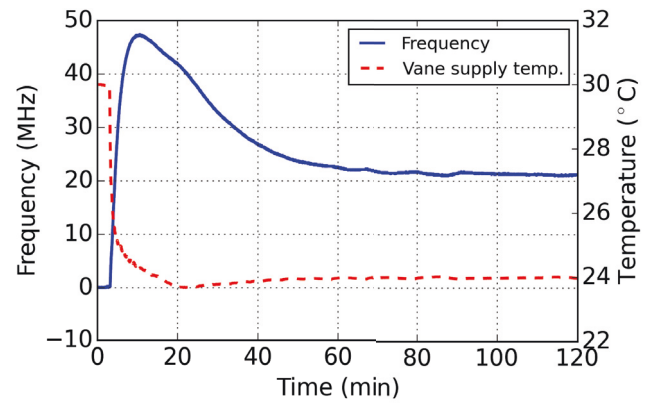

Figure 4: Uncontrolled frequency response to a 5 degree step change in temperature of vane water from helical mixer.

ings [10]. MPC testing should begin immediately after CW conditioning is complete.

The physical processes relevant to control have timescales on the order of seconds or minutes. Practically, then, resonance control may be managed in software, by a set of Python scripts running on a rack-mounted server. The control software interfaces with the low-level RF system to acquire information about SEL/GDR transitions, and cavity amplitude and phase. Valves and other hardware are administered by an array of PLCs. High-level control operations and data logging are handled through Fermilab's ACNET framework.

OPERATIONAL EXPERIENCE

The RFQ was conditioned in pulsed mode up to 120 kW (66 kV inter-vane voltage, 10% above nominal operating field) at 10 Hz with a 5-ms pulse width during February of 2016. Once conditioning was complete, several days were spent mapping the parameter space relevant to MPC of RFQ resonance. The wall and vane mixing valve settings and RF amplitude were varied in order to study flow and frequency response, as illustrated in Figure 5, and as discussed in more detail in Reference [10].

Detailed system characterization of this sort is used to improve a simple model relating temperature shifts to motion of the RFQ's resonant frequency [11]. This model, in turn, can be used for efficient system studies and can also inform the design of model predictive control algorithms. This model uses approximations to the geometry in order to study bulk temperature and frequency relationships. It includes coupling between the vane and wall cooling circuits, heat transfer in the RFQ body, and heat transfer to the environment. Figure 6 illustrates the agreement between this model and observed temperatures for a few steady-state test cases.

First beam through the RFQ

The first beam through the RFQ occurred on March 23, 2016. ≤ 10 -mA beam was delivered, with 10-Hz and a 20-

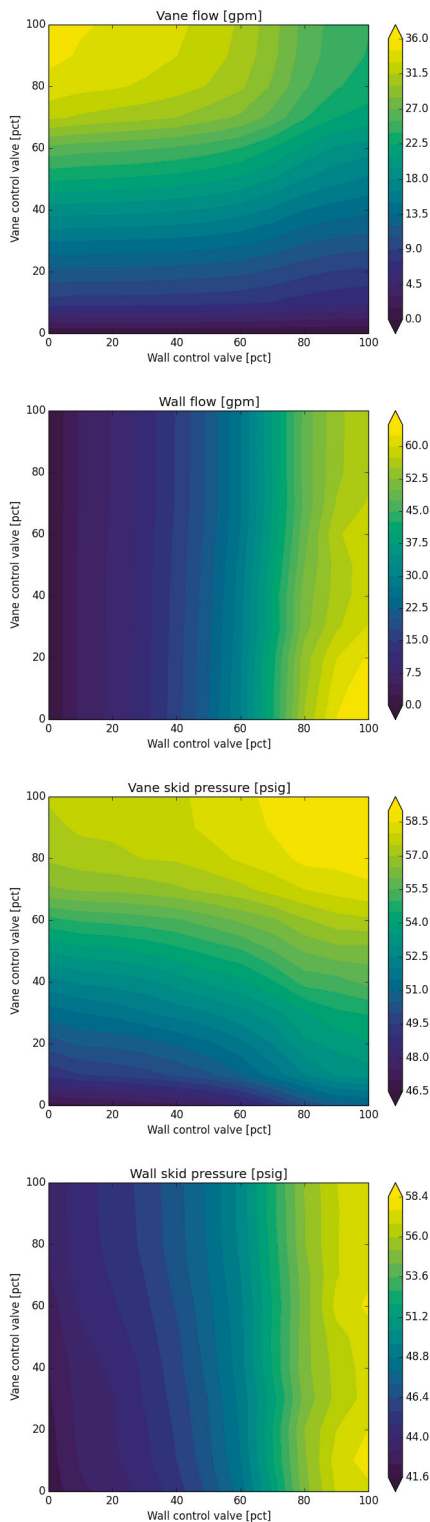

Figure 5: Valve flow studies for control calibration.

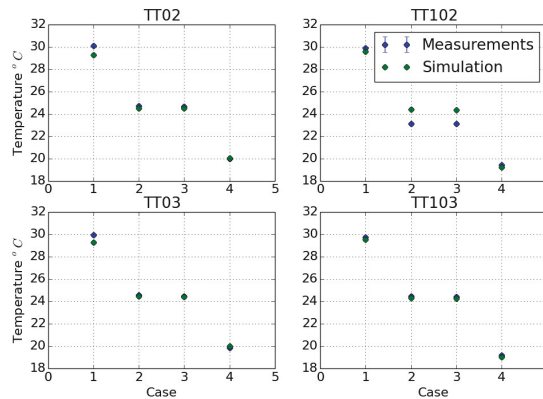

Figure 6: RFQ thermal model and experimental observation for steady-state operation. Each “case” on the horizontal axis represents a configuration of the RFQ and cooling system (gradient, flow control valve settings, etc.) during operation. The model prediction and temperature sensor readout are compared at various locations in the system, as shown in Figure 3.

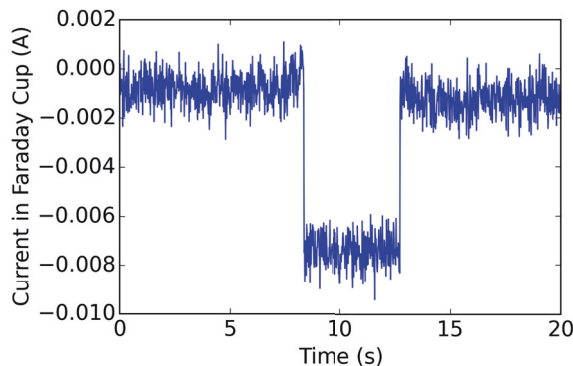

Figure 7: 8 mA measured by Faraday cup during first beam test through RFQ.

FUTURE PLANS

CW conditioning of the RFQ is currently underway, at the time of writing. As with pulsed operation, the parameter space relevant to resonant control must be thoroughly mapped (per Figure 5) in order to train the model predictive controller. Once the RFQ is conditioned and this parameter space is characterized, we will evaluate the performance of model predictive control relative to linear control methods.

ACKNOWLEDGEMENTS

Beam was successfully transported through the RFQ thanks to hard work from many people. Here we acknowledge contributions from people most immediately connected to RFQ resonant control issues, including Curt Baffes, Jean-Paul Carneiro, Bruce Hanna, Lionel Prost, and Alexander Shemyakin at Fermilab, and John Staples, Derun Li, Steve Virostek, and Andrew Lambert at LBNL. Special thanks to Ralph Pasquinelli and Dave Peterson for their work on high-level RF and instrumentation.

μ s pulse width. A Faraday cup measured current from this initial operation, illustrated in Figure 7.

REFERENCES

- [1] S. Holmes *et al.*, “PIP-II Status and Strategy,” presented at IPAC’15, Richmond, VA, USA (2015).
- [2] L. Prost, A. Shemyakin, “The PXIE LEPT Design Choices,” presented at IPAC’16, poster MOPOY049, *these proceedings*.
- [3] A. Shemyakin *et al.*, “Status of the Warm Front-End of PXIE,” presented at LINAC’14, Geneva, Switzerland (2014).
- [4] O. Prontichev, S. Kazakov, “Mechanical design of a high power coupler for the PIP-II 162.5 MHz RF quadrupole,” presented at SRF’15, Whistler, BC, Canada.
- [5] D. Li *et al.*, “Progress of the RFQ Accelerator For PXIE,” presented at IPAC’13, Shanghai, China (2013).
- [6] P.N. Ostroumov *et al.*, “Development and beam test of a continuous wave radio frequency quadrupole accelerator,” PRST-AB **15**, 110101 (2012).
- [7] Wang Jing *et al.*, “Multi-physics analysis of the RFQ for injector scheme II of C-ADS driver linac,” Chinese Physics C **38**, 10 (2014).
- [8] A. Lambert *et al.*, “FNAL PXIE - 162.5 MHz RFQ general RF, thermal, mechanical, RF finite element analysis,” LBNL engineering note 10773A, 11 Jan. 2013.
- [9] A.L. Edelen *et al.*, “Neural networks for modeling and control of particle accelerators,” *IEEE Trans. Nucl. Sci.* **63**, 2 (2016).
- [10] A.L. Edelen *et al.*, “Neural network model of the PXIE RFQ system and resonant frequency response,” presented at IPAC’16, poster THPOY020, *these proceedings*.
- [11] J. Edelen *et al.*, “First principles modeling of RFQ cooling systems and resonant frequency responses developed at PXIE,” publication pending.