



Improvement of the L1 trigger for the ATLAS muon spectrometer at high luminosity



P. Schwegler, O. Kortner, H. Kroha, R. Richter^{*,1}

Max Planck Institut für Physik, Munich, Germany

ARTICLE INFO

Available online 30 January 2013

Keywords:

Tracking detectors
Level-1
Trigger
ATLAS
Muon spectrometer

ABSTRACT

When the peak luminosity of $10^{34} \text{ cm}^{-2} \text{ s}^{-1}$ of the LHC will be increased by a factor of 5–7 in about a decade from now (“SLHC”), the selectivity of the ATLAS Level-1 (L1) triggering system will have to be improved in order to cope with the maximum allowed trigger rate of about 100 kHz. For the L1 trigger of the ATLAS Muon Spectrometer this calls for an increase of the p_T -threshold for single muons. In the present L1 muon trigger system, however, the effective p_T -threshold is not very sharp due to the limited spatial resolution of the trigger chambers, resulting in a majority of L1 triggers from muons below threshold. We describe a new, high-speed readout system of the Monitored Drift Tube chambers, which allows to supply the precision coordinates of the candidate muon to the L1 trigger, resulting in an accurate momentum determination, a sharpened p_T -threshold and an efficient rejection of unwanted L1 triggers from low- p_T muons.

© 2013 EURATOM. Published by Elsevier B.V. Open access under [CC BY-NC-ND license](https://creativecommons.org/licenses/by-nc-nd/4.0/).

1. Introduction

The increase of LHC luminosity by nearly an order of magnitude is motivated by the search for new physics processes, which may be found in rare event signatures like high- p_T leptons, large missing E_T and others. The capability to selectively trigger on high- p_T muons ($> 20 \text{ GeV}$) in the ATLAS Muon Spectrometer (MS) requires an improvement of the spatial resolution of the trigger chambers in order to allow the determination of the sagittae, i.e. the p_T of the candidate muons, with sufficient accuracy. Presently, the large majority of apparent high- p_T L1 triggers is caused by muons below the p_T -threshold. At the SLHC this would lead to unacceptably high trigger rates. In some regions of the detector new trigger chambers with improved performance will be built for the phase-1 upgrade in 2018 (Small Wheel), however, in Barrel and Big Wheel most of the chambers will have to subsist, and only modifications of the readout electronics seem to be a realistic option.

2. Concept for the L1 trigger improvement

The basic idea for improved p_T resolution for the L1 trigger is to combine the good time resolution of the trigger chambers with the excellent position resolution of the close-by Monitored Drift Tube (MDT) chambers [1,2], see Fig. 1. This requires the precision

hits of the MDT to be available for the L1 decision shortly after the passage of the particle, respecting the maximum allowed latency. Presently, due to technical limitations in various ATLAS sub-detectors, the maximum L1 latency is $2.5 \mu\text{s}$. In the phase-2 upgrade, however, the L1 latency will be increased to more than $6.4 \mu\text{s}$, allowing sufficient time for the transfer of MDT track coordinates and for their combination with the trigger chamber information.

The implementation of this scheme is facilitated by the fact that high- p_T tracks, due to their small curvature, have a simple projective hit pattern and, if relevant for physics, originate from the primary vertex. The coordinate of a high- p_T muon candidate in the outer trigger chamber thus defines a straight search road for the expected MDT hits, the width of the search road being of about one MDT tube diameter (30 mm). Only MDT hits close to the search road are relevant for the p_T determination and need to be read out for the L1 trigger. The large majority of “background” hits from γ and neutron conversions (see Fig. 2, left) can be ignored for the trigger decision. This limitation of the data volume leads to a dramatic reduction of the required data transfer time and greatly simplifies algorithms for the trigger decision. Another consequence of track straightness is that high- p_T muons mostly travel within *one* trigger tower. Unlike in the case of low- p_T tracks, the crossing of tower boundaries does not have to be treated by the logic of the high- p_T trigger.

3. Technical realization

The technical realization of this trigger concept requires a fast communication path between the trigger chamber logic and the

^{*} Corresponding author. Tel.: +49 8932354358; fax: +49 8932354305.

E-mail address: richterr@mpp.mpg.de (R. Richter).

¹ ©CERN for the benefit of the ATLAS collaboration. Open access under [CC BY-NC-ND license](https://creativecommons.org/licenses/by-nc-nd/4.0/).

MDT readout, separately for each tower. The existing MDT readout (Ref. [3]), has to be complemented by an independent, fast readout path. To assure strict correspondence between trigger chamber data and the MDT coordinates, the readout must be synchronous with the beam crossing clock, i.e. the MDT data must be delivered to the L1 trigger logic a fixed, predefined interval after the beam crossing tagged by the L1 trigger.

Fig. 3 shows the new readout scheme of the MDT, where hits are recorded twice, once in a TDC for “normal”, slow readout and, independently, in a bank of scalers, one scaler per tube, for fast readout. Scalers are started by a hit in the corresponding tube. All scalers are stopped on reception of a request from the trigger chamber logic of this tower, asking for MDT coordinate information. Scalers, not stopped during the maximum drift time, will be automatically reset, waiting for the next hit. Requests from the trigger chambers will have to arrive a fixed time interval after the passage of the particle, pointing to a definitive beam crossing. This way, the scaler readings correspond to the *absolute* drift time in the MDT tube, i.e. to the distance of the track to the wire. The sum of the drift times in two adjacent tubes, subsequently crossed by a muon, must therefore fall inside a predefined time interval, corresponding to the maximum drift time. This

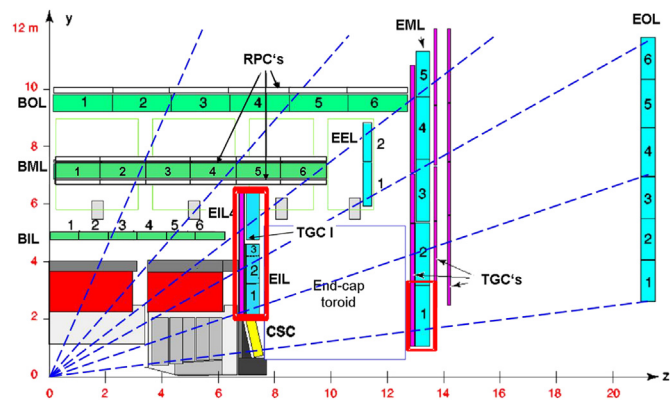

Fig. 1. Tower structure of the muon spectrometer showing the matching of trigger and precision chambers. High- p_T tracks are “nearly straight” and mostly travel inside a given tower. Each tower only contributes a small rate of high- p_T L1 triggers (< 100 Hz), resulting in low bandwidth requirements for the readout.

constraint on the drift time sum provides a valuable quality check on the absence of γ -conversions, which tend to reduce the drift time sum, if the conversion was closer to the wire than the track.

As the full spatial resolution of the MDT of < 100 μm is not needed for the L1 trigger, the clock frequency for the drift time measurement (i.e. the clock driving the scalers) can be relaxed to the 40 MHz of the incoming clock. Given the average drift velocity of 20 $\mu\text{m}/\text{ns}$ this provides a spatial resolution of about 1 mm, sufficient for the required sagitta resolution. At this reduced level of precision, corrections for the non-linear $r-t$ relation as well as for temperature and magnetic field variations can be neglected, simplifying the complexity of algorithms and saving processing time and latency.

4. Summary

The upgrade scheme for the Level-1 muon trigger presented above allows to sharpen the threshold of the high- p_T trigger by about an order of magnitude, sufficient for the luminosity increase, as envisioned for future LHC operation. Implementing this scheme, most of the existing trigger chambers in barrel and endcap can stay in place. The readout electronics of trigger as well as MDT chambers will have to be replaced in order to allow

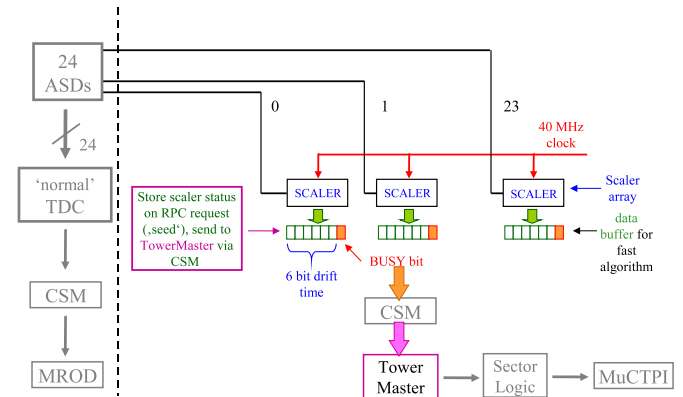

Fig. 3. Fast readout of drift times using one scaler per tube.

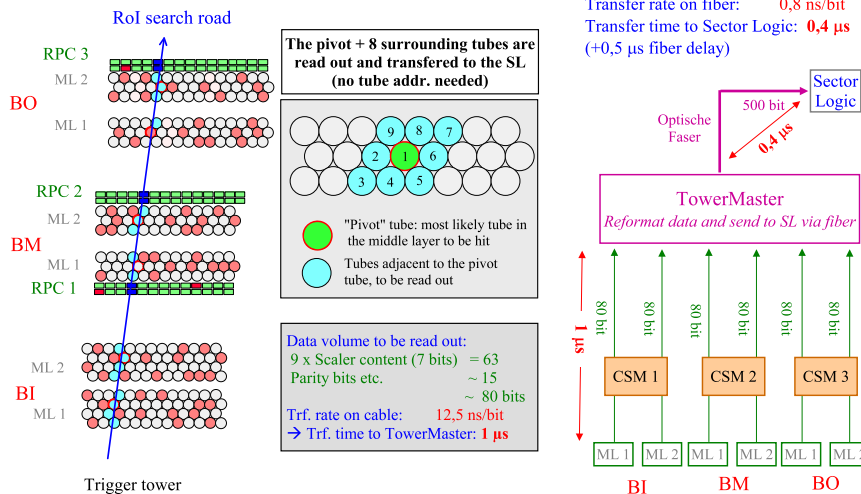

Fig. 2. Left: only MDT hits along the search road are read out, reducing the required readout bandwidth. Center: the drift time of a fixed number of tubes around the search road will be read out for each multilayer (ML), resulting in a data volume of about 80 bit. Right: the fast readout scheme of the MDT.

communication between the two systems. In addition, a number of electronics units along the readout path will have to be developed to assure safe data exchange between the chambers at the frontend and the logic units in the counting room, where the final trigger decision is taken. Design, prototyping, production and installation will require a significant effort and a strong contribution from the ATLAS muon spectrometer community.

References

- [1] ATLAS Collaboration, Technical Design Report for the ATLAS Muon Spectrometer, CERN/LHCC/97-22, May 1997.
- [2] The ATLAS collaboration, The ATLAS Experiment at the CERN Large Hadron Collider, Journal of Instrumentation 3 (2008) S08003.
- [3] Y. Arai, et al., ATLAS Muon Drift Tube Electronics, Journal of Instrumentation 3 (2008) P09001.