

QUADRUPOLE LENS AND EXTRACTION MAGNETS OF A MINIATURE RACE-TRACK MICROTRON*

I.Yu. Vladimirov[#], N.I. Pakhomov, V.I. Shvedunov, MSU, Moscow, Russia
 V.V. Zakharov, Tehnomag ltd., Kaluga, Russia
 Yu.A. Kubyshev, UPC, Barcelona, Spain
 J.P. Rigla, I3M, Valencia, Spain

Abstract

A compact 12 MeV race-track microtron (RTM) which is under construction at the Technical University of Catalonia includes a quadrupole magnet for horizontal beam focusing and four dipole magnets for beam extraction. As the source of the magnetic field in these magnets a rare-earth permanent magnet (REPM) material is used. In the article the main design characteristics of the quadrupole lens and extraction dipoles are described and a procedure of tuning of their magnetic fields is described. We report on the manufacturing of these magnetic systems and results of the tuning of their magnetic fields.

INTRODUCTION

The Technical University of Catalonia (UPC) in collaboration with the Skobeltsyn Institute of Nuclear Physics of the Moscow State University (SINP MSU) and CIEMAT (Madrid) is building a miniature RTM. RTM is intended for use in intraoperative radiation therapy and can be used in radiography and inspection complexes. This compact accelerator was proposed in [1], the status of work on the RTM is described in [2].

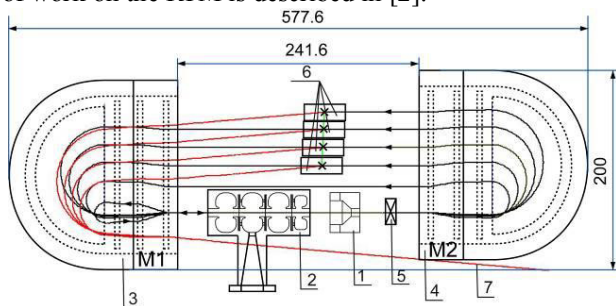

Figure 1: RTM scheme.

Table 1: RTM Parameters

Parameter	Value
Beam energies	6, 8, 10, 12 MeV
Operating frequency	5712 MHz
Synchronous energy gain	2 MeV
Pulsed beam current at the RTM exit	5 mA
End magnets field	0.8 T
Injection energy	25 keV

*Work supported by grants 2009 SGR 1516 of AGAUR (Generalitat of Catalonia) and FIS2012-38480 of MINECO (Spain).
[#] timerke@mail.ru

A schematic view of the RTM is given in Fig. 1. It consists of electron gun (1), accelerating structure (linac) (2) with four accelerating and three coupling cavities, two end magnets M1 and M2 (3, 4) and a quadrupole (5). These elements are precisely fixed at a common rigid platform placed inside a steel box which plays the role of the vacuum chamber. The beam can be extracted from any of the 6, 8, 10 and 12 MeV orbits with extraction magnets (6) and exits the RTM along the output trajectory (7). The main RTM parameters are listed in Table 1.

Quadrupole lens is focusing the beam in the median plane of the end magnets (horizontal plane). Its vertical plane defocusing is compensated by the end magnets fringe field (see [6]). The focusing powers of the quadrupole and fringe field were adjusted to provide stable transverse oscillations in both planes.

Each of the four extraction dipole magnets when placed at the corresponding orbit provides beam deflection in the horizontal plane for 5° (Fig. 1). The position of each magnet along the orbit is chosen in such a way that the deflected beam crosses the previous orbit at the edge of the end magnet main pole. After passing through M1 the deflected beam exits the RTM along the path common for all orbits. The extraction magnets are displaced with respect to each other in the vertical plane and are hold by a rigid frame. Placing of a magnet at the corresponding orbit is achieving by moving the frame vertically by means of step motor fixed outside the vacuum box.

With increase of the beam energy the distance between the RTM orbits is approaching $d = \nu\lambda/\pi$, where ν is an integer number and λ is the RF field wavelength in free space. For our RTM $\nu=1$, $\lambda=5.25$ cm, so that $d=1.67$ cm. For so small distance the quadrupole and extraction magnets must have as large working aperture to external dimension ratio as possible. Together with the necessity to place elements in vacuum this consideration defined our choice of REPM material as a field source. The quadrupole and extraction magnets design is of the QSM type proposed in [3].

QUADRUPOLE

According to results of RTM beam dynamics simulations in order to provide stable oscillations in the horizontal plane a quadrupole with effective length $L_{eff} = 2$ cm must have gradient G in the range 1–2 T/m. Schematic view of the quadrupole designed according to [3] is shown in Fig. 2.

Triangular-base REPM blocks generate a field in a volume bounded by the internal yoke surface. The field

gradient of infinitely long quadrupole with notations of Fig. 2 is defined by $G = \frac{B_r}{2a} \sin 2\Psi$, where B_r is the residual magnetization of a REPM block. We chose $a = 8$ mm, $\Psi = 15^\circ$, so that to get $G = 1-2$ T/m one needs $B_r = 30 - 60$ mT. Since it is difficult to control so small value of the residual magnetization we increased it by decreasing the effective length of the quadrupole using short REPM blocks with $l = 3$ mm (Fig. 2). In order to protect the neighboring orbit from the stray magnetic field the length of the quadrupole yoke was taken $L = 20$ mm. The quadrupole width is $S = 21$ mm, the internal yoke dimension is $s = 16.6$ mm.

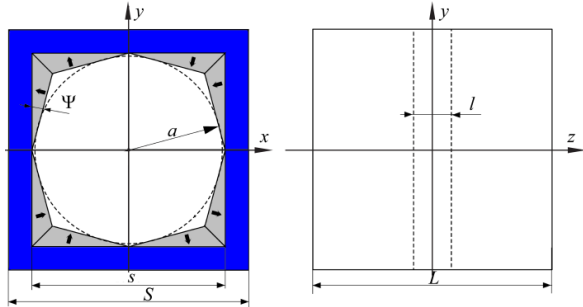

Figure 2: Quadrupole schematic drawing. Gray color indicates REPM blocks, blue – steel yoke. Black arrows show the REPM block magnetization direction.

For a short quadrupole with effective length less than the radius of its aperture at any plane perpendicular to longitudinal axis z , including $z = 0$, the transverse field components B_x, B_y show strong nonlinear dependence on y and x , respectively.

Focusing properties of such lens can be defined via the product of the effective length and effective gradient $L_{eff}G_{eff} = \frac{\int_{-\infty}^{+\infty} B_y(x,y=0,z)dz}{x} = \frac{\int_{-\infty}^{+\infty} B_x(x=0,y,z)dz}{y}$. The value of the residual magnetization which provides $L_{eff}G_{eff} = 0.02-0.04$ T was defined in ANSYS simulations [4,5] and is equal to $B_r = 0.2-0.4$ T.

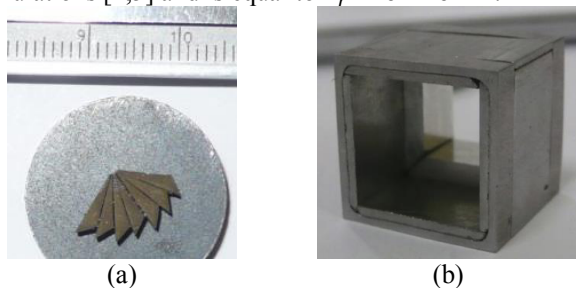
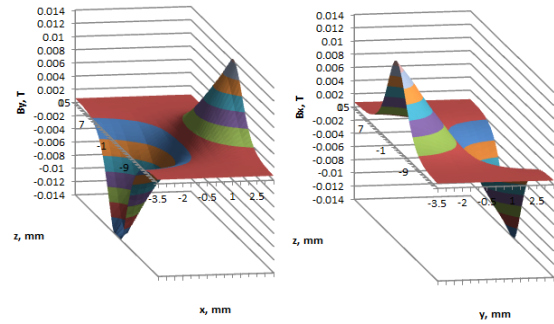

Figure 3: (a) SmCo blocks for the quadrupole. (b) Assembled quadrupole.

The engineering design of the quadrupole which permitted its assembling without glue and screws using only special clamps was carried out. The SmCo was used as the material for the REPM blocks. In Fig. 3 cut SmCo blocks and the assembled quadrupole are shown.

The SmCo blocks shown in Fig. 3 (a) were magnetized in a heated state in a constant magnetic field. Then the quadrupole was assembled and the field distributions in the $x - z$ and $y - z$ planes (Fig. 4 (a)) were measured by means of a Hall probe at an automated measuring table [6]. From the plot of the B_y -integral $I_y(x, y = 0) = \int_{-\infty}^{+\infty} B_y(x, y = 0, z) dz$ (Fig. 4 (b)) it follows that $L_{eff}G_{eff}|_y = 0.0349$ T. For the x -component $L_{eff}G_{eff}|_x = -0.0345$ T. These values are within the range providing stable transverse beam oscillations in the RTM.



(a)

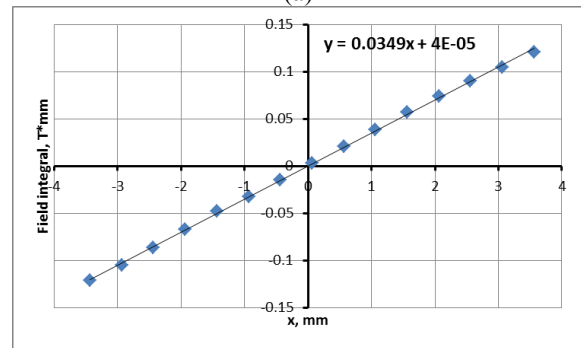

(b)

Figure 4: (a) Quadrupole field in the $x - z$ and $y - z$ planes. (b) The B_y -integral as function of x .

EXTRACTION MAGNETS

The basic requirements to extraction magnets are the following: the field integrals in the horizontal plane must have values given in Table 2; the field integral in the vertical plane must be close to zero; the aperture for the beam passage must be not less than 8 mm in diameter.

Table 2: Field Integrals of the Extraction Magnets

Orb.	$E, \text{ MeV}$	$\int_{-\infty}^{+\infty} B_y(z) dz _{proj}$	$\int_{-\infty}^{+\infty} B_y(z) dz _{meas}$
3	6.009	1.89 T×mm	1.89 T×mm
4	8.036	2.47 T×mm	2.49 T×mm
5	10.048	3.05 T×mm	3.08 T×mm
6	12.055	3.63 T×mm	3.66 T×mm

The dipole design approach described in [3] requires a special form of the internal surface of the vertical wall of the yoke and leads to a considerable effective yoke

thickness. For our extraction magnets we used simplified geometry shown in Fig. 5 for which the deflecting field is produced by properly magnetized REPM blocks placed in the upper and lower parts of the yoke. The shape of additional side blocks and their magnetization were optimized with the PANDIRA code [7] in order to improve the field uniformity along the x -axis.

All four magnets have the same length of the yoke and of the REPM blocks equal to 20 mm. The required field integral values are obtained by a proper REPM blocks magnetization. To avoid the influence of the stray magnetic field on neighboring orbits each extraction magnet is surrounded by a magnetic screen of the length 40 mm.

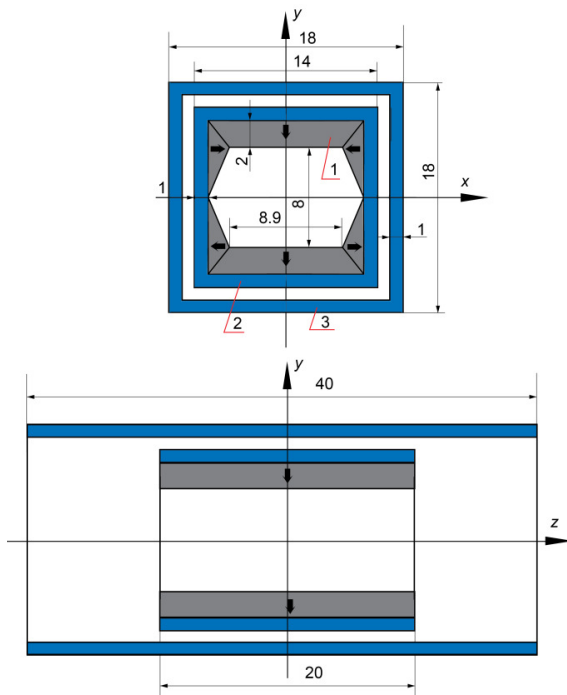

Figure 5: Cross sections of the extraction magnet. Here (1) is an REPM block, (2) – yoke, (3) – magnetic screen. The dimensions are in mm.

Similar to the quadrupole the extraction magnets design permits their assembling without glue and screws using special clamps and locks. The assembled extraction magnets are shown in Fig. 6.



Figure 6: Assembled extraction magnets.

Before the extraction magnets assembling the REPM (SmCo) blocks were magnetized in a constant magnetic field to the design level. After this the magnets were

assembled, the field distributions in the $x - z$ and $y - z$ planes were measured, and the deflecting field integral $I_y(x) = \int_{-\infty}^{+\infty} B_y(x, y = 0, z) dz$ and parasitic field integral $I_x(y) = \int_{-\infty}^{+\infty} B_x(x = 0, y, z) dz$ were calculated. To adjust $I_y(x)$ to the design values given in Table 2 and to decrease $I_x(y)$ to 3-5% of the $I_y(x)$ value a magnetization/demagnetization technique with pulsed magnetic field was used.

The final values of $I_y(x = 0)|_{meas}$ are given in the last column of Table 2. As one can see the differences between the design and measured field integral values are within 1%. Therefore the error in the deflecting angle is less than 1 mrad and the vertical beam deflection due to the parasitic field of the magnets is also less than 1 mrad.

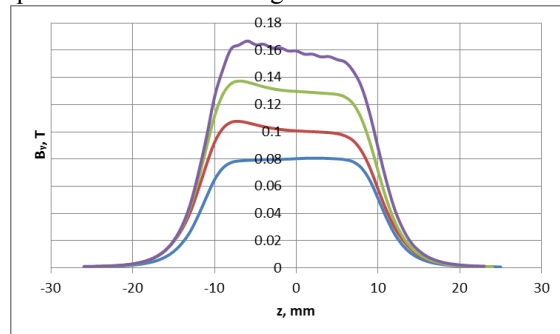

Figure 7: Magnetic field $B_y(x = 0, y = 0, z)$ of the extraction magnets.

In Fig. 7 the magnetic field distributions along z -axis, $B_y(x = 0, y = 0, z)$, for four extraction magnets are shown. Though the distributions are non-uniform in the central part due to a non-uniformity of REPM blocks magnetization, this does not affect the extracted beams trajectory in an essentially way.

CONCLUSION

We designed, constructed, assembled and tuned the quadrupole magnet and four extraction dipole magnets which will be installed in the miniature 12 MeV RTM.

REFERENCES

- [1] B.S. Ishkhanov et al., RuPAC'04, Dubna, 2004, p. 474 (2004).
- [2] Yu.A. Kubyshin et al., PAC'09, Vancouver, 2009, p. 2775 (2009).
- [3] V.S. Skachkov, Nucl. Inst. and Meth. A 500, p. 43 (2003).
- [4] ANSYS Multiphysics, www.ansys.com
- [5] J.P. Rigla, "Design and characterization of magnetic systems in race-track microtrons", PhD Thesis, Universitat Politcnica de Catalunya, Barcelona (2013).
- [6] I.Yu. Vladimirov et al., "Rare-earth end magnets of a miniature race-track microtron and their tuning", IPAC'14, to be published.
- [7] K. Halbach et al., Particle Accelerators 7, p. 213 (1976).