

Development of digital data acquisition system for MONSTER

A. Banerjee^{1,2}*, P. Kundu³, K. Banerjee^{1,2}, S. Gayen⁴, R.K. Paul^{1,2}, P. Dhara^{1,2},
 P. Roy^{1,2}, G. Mukherjee^{1,2}, A.K. Saha¹, R. Shil⁵, T. Samanta^{1,2}, T. Martinez⁶,
 D. Villamarin⁶ and D. Cano-Ott⁶

¹Variable Energy Cyclotron Centre, Kolkata-700064, India

²Homi Bhabha National Institute, Training School Complex, Anushaktinagar, Mumbai- 400094, India

³Department of Physics, IIT Kharagpur, Kharagpur-721302, India

⁴Department of Physics, IIT (ISM) Dhanbad, Jharkhand-826004, India

⁵Department of Physics, Visva-Bharati University, Santiniketan-731235, India

⁶Centro de Investigaciones Energéticas, Medioambientales y Tecnológicas, Madrid-28040, Spain

* email: a.banerjee@vecc.gov.in

MODuler Neutron SpectromETER (MONSTER) is being developed for the decay spectroscopy experiment at Facility for Antiproton and Ion Research (FAIR) [1,2]. In this paper, we present a digital data acquisition (DAQ) system being developed for the neutron time of flight (TOF) measurement. An external trigger mechanism was used to acquire the CeBr₃ and BC501A detector pulses in coincidence mode. A ²⁵²Cf fission neutron source was placed in front of the CeBr₃ detector and one BC501A liquid scintillator detector was placed at a distance of 150 cm from the CeBr₃ detector. Fig 1. displays the electronic circuit used to generate the external trigger for the coincidence measurement. The signals from the CeBr₃ and the BC501A scintillator detectors were connected to the Constant Fraction Discriminator (CFD) modules. The output signal of the CFD connected to the CeBr₃ detector was delayed and placed inside the CFD pulse of BC501A after widening the latter by 200ns. This increase in width is required to accommodate all the neutron pulses corresponding to different neutron energies for TOF measurement. The logical AND of these two CFD signals produced the start signal for the TOF measurement as shown in Fig 2. This trigger is used as an acquisition trigger for the digital DAQ system. The pulses for the CeBr₃ and BC501A detectors were acquired using the DAISY [3] software developed for the MONSTER.

DAISY software uses the SP Devices make ADQ14-FWDAQ card to acquire the raw

pulses from the detector using a leading edge trigger on the first channel of the digitizer. This card contains four channel 14-bit, 1 Gsample/s fast ADC to digitize the detector pulses [3]. An oscilloscope software has been developed that takes the binary data generated by the DAISY for display and further processing. Each raw pulse collected using the digitizer contains 1000 sample points. The separation between each sample point was 1 ns. The acquired pulse in the digital oscilloscope is displayed in Fig 3.

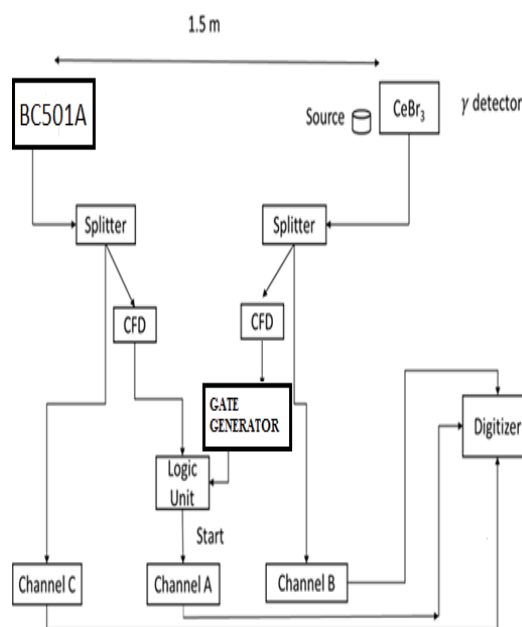

Fig.1: External trigger generation circuit for coincidence data collection.

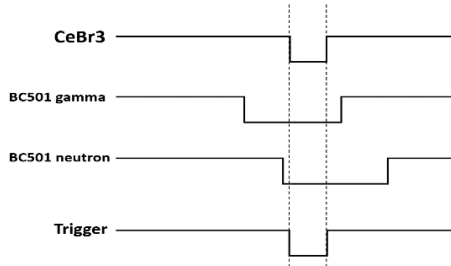

Fig 2: Timing Diagram for the Trigger.

A digital Constant Fraction Discrimination (CFD) algorithm was developed to generate the stop signal for the TOF measurement using the digitized pulse of the BC501A detector. The input signal of the BC501A detector called X is shown in Fig 3 using the blue line. The delay, and attenuation factor used in the digital CFD are T_d and f respectively. The bipolar signal called Y is shown (in green) in Fig 3 and n is the sample index. The following equation represents the algorithm used to generate the bipolar pulse Y .

$$Y[n] = X[n] - f * X[n - T_d]$$

The zero cross-over time T at which the CFD output is generated for the digital pulses is calculated from the start time T_s , rise time T_r and the delay T_d used for each pulse. The relation between these values can be described as follows.

$$T = T_s + fT_r + T_d$$

Here, T_d is 20ns, as rise time t_r is 4ns. Attenuation factor f is 0.2. The time of flight (TOF) is calculated as $(T - T_d)$, which is shown in Fig 4. The different distributions for the neutron and the γ - events are clearly visible.

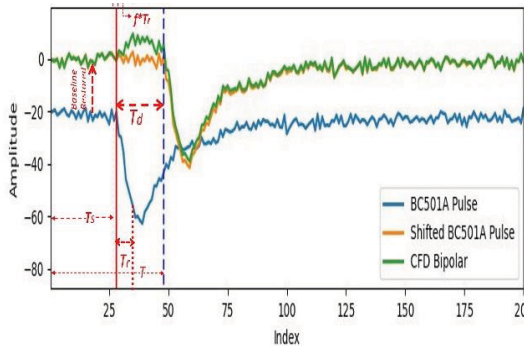

Fig 3: Digital pulse for BC501A and its CFD.

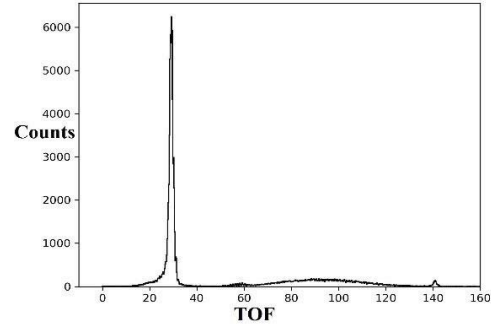

Fig.4: Time of Flight distribution.

The acquired pulses were also used for pulse shape discrimination (PSD) [4] using the charge comparison method (CCM) [4]. The pulses were corrected for the baseline drift and were filtered using the Fast Fourier Transform (FFT), and the Inverse of Fast Fourier Transform (IFFT) to remove noise before applying the PSD algorithm [4]. The two-dimensional histogram for the TOF vs PSD is shown in Fig 5. Two different groups for neutron and γ - events are visible.

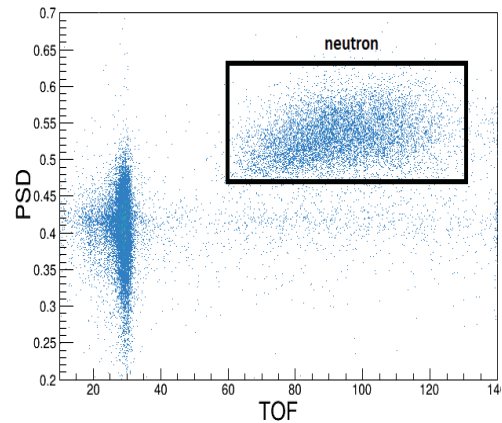

Fig 5: PSD vs TOF.

- [1] A.R. Garcia et. al. JINST 7, C05012, 2012.
- [2] K. Banerjee, et. al., DAE symposium, Phys., 58, 888 (2013).
- [3] D. Villamarin et. al., NIMA 1055, 168526 (2023).
- [4] A. Banerjee et. al., DAE symposium Phy,67, 1319(2023)