

PAPER • OPEN ACCESS

Quarter-Wave buncher for NICA project

To cite this article: M Trushin *et al* 2017 *J. Phys.: Conf. Ser.* **941** 012099

View the [article online](#) for updates and enhancements.

Related content

- [The NICA/MPD Collaboration](#)
- [Feasibility Study of \(1020\) Production at NICA](#)
Lyubka Yordanova
- [Prospects of Elliptic Flow Studies at NICA/MPD](#)
Nikolay Geraksiev

Quarter-Wave buncher for NICA project

**M Trushin^{1,2}, R Fatkullin^{1,2}, A Sitnikov^{1,2}, D Seleznev², V A Koshelev²,
A S Plastun², S V Barabin², A V Kozlov², V G Kuzmichev², G N Kropachev² and
T Kulevoy^{1,2}**

¹ National Research Nuclear University MEPhI, Moscow, Russia

² NRC “Kurchatov Institute” FSBI “SSC RF ITEP”, Moscow, Russia

E-mail: rdfatkullin@gmail.com

Abstract. This paper represents the results of modeling the electrodynamic characteristics (EDC) for a quarter-wave coaxial beam buncher, simulation of thermal loads of the buncher, modeling of the mechanical changes in the geometric parameters caused by the thermal load of the buncher and modeling of the new EDC depended on this changes.

1. Upgrading of the injector of light ions in the NICA project

The replacement of the electrostatic pre-injector of the linear accelerator LU-20 (NICA [1]) with the RFQ accelerator was carried out in 2016 as part of the polarized light ion beams project [2].

At the moment, a new pre-injector RFQ accelerator is put into operation [3]. In order to provide the phase beam distribution prior to injection in LU-20, it is proposed to use a buncher located in the transport channel between the RFQ accelerator and LU-20 (inside the LU-20’s vacuum tank). For these purposes the two-gap quarter-wave coaxial buncher (figure 1) was developed by the ITEP’s engineers. The characteristics of the developed buncher are shown in Table 1.

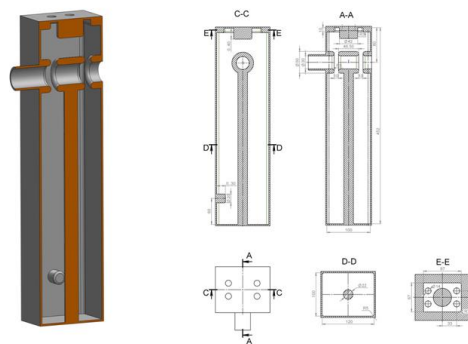

Figure 1. Quarter-wave coaxial buncher.

The buncher is a rectangular copper coaxial quarter-wave resonator with one drift tube, two drift half-tubes and two plungers: for manual tuning and for so-called automatic frequency control (AFC) (figure 2). The LU-20 accelerator operates in an auto-generator mode, so it is necessary to adjust the resonant frequency of the buncher. Resonant frequencies of the buncher and LU-20 accelerator must

coincide for effective operation. When the resonant frequency of LU-20 is changed (for example, due to heating of the accelerator's structure), LLRF (low level RF) device receives the signal from the measuring loop and changes the frequency of the buncher by rotation of the AFC plungers.

Table 1. The characteristics of the buncher.

Name	Value
Resonant frequency f_0 , MHz	145.2
Electric field (for C^{4+} ions), kV/cm	75
Overall dimensions of the buncher, mm	115x125x502

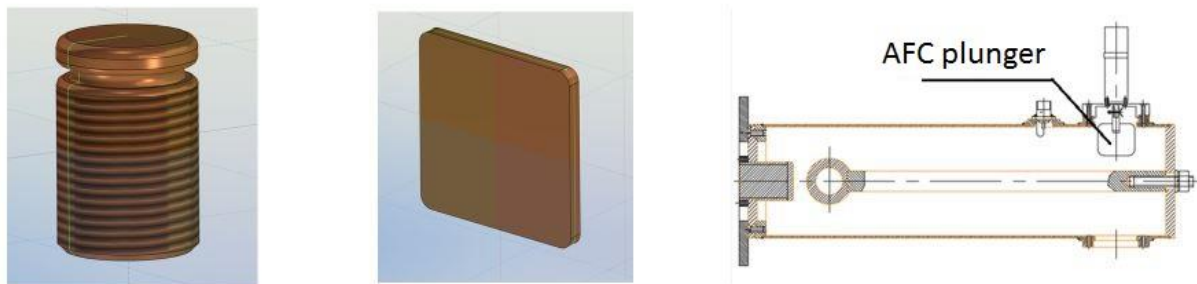

Figure 2. Frequency change plungers.

2. Simulation

Simulation of the EDC of the quarter-wave buncher was performed in CST (Student Edition). The model used in the simulation is shown in figure 3. Overall dimensions of the model is 115x125x502 mm. The material or resonator walls used for calculation is copper.

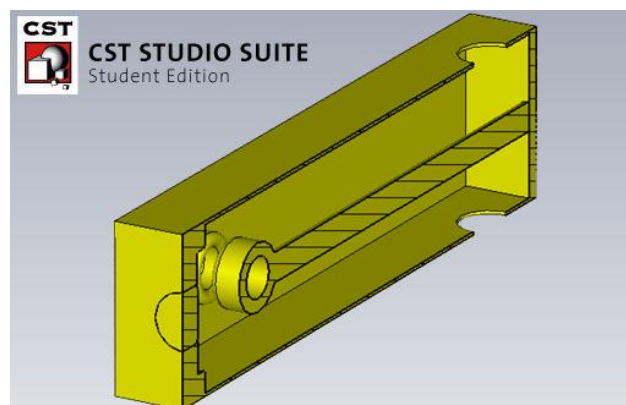

Figure 3. 3D model of the buncher without plungers.

Simulation of EDC includes:

- simulation of the buncher's fields distribution without plungers, at 1 J stored energy in the resonator (figure 4);

- investigation of the resonant frequency dependence based on the location of both plungers (figure 5);

Simulating of thermal losses and mechanical changes in geometric parameters of a resonator caused by a thermal load consists of:

- investigation of the temperature distribution in the buncher's structure as a function of the time operated (figure 6);
- simulation of deformations in the structure in a thermal stationary mode;
- simulation of the deviation of the resonant frequency of the deformed buncher from the frequency of the undeformed buncher.

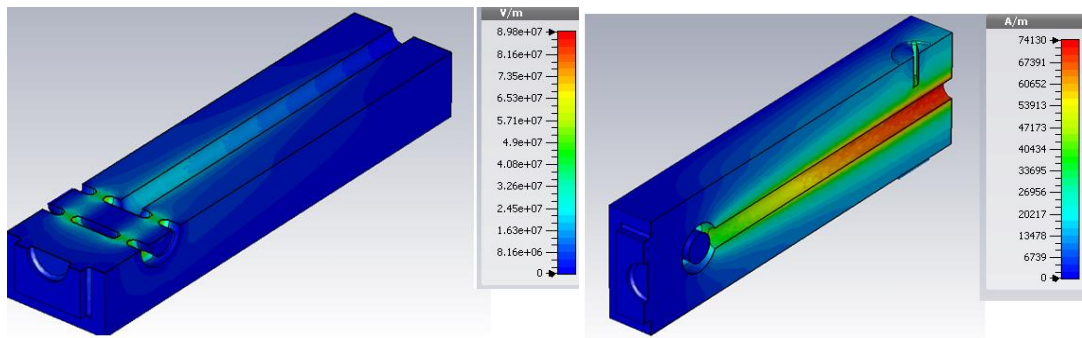

Figure 4. The distribution of electric (left) and magnetic (right) fields.

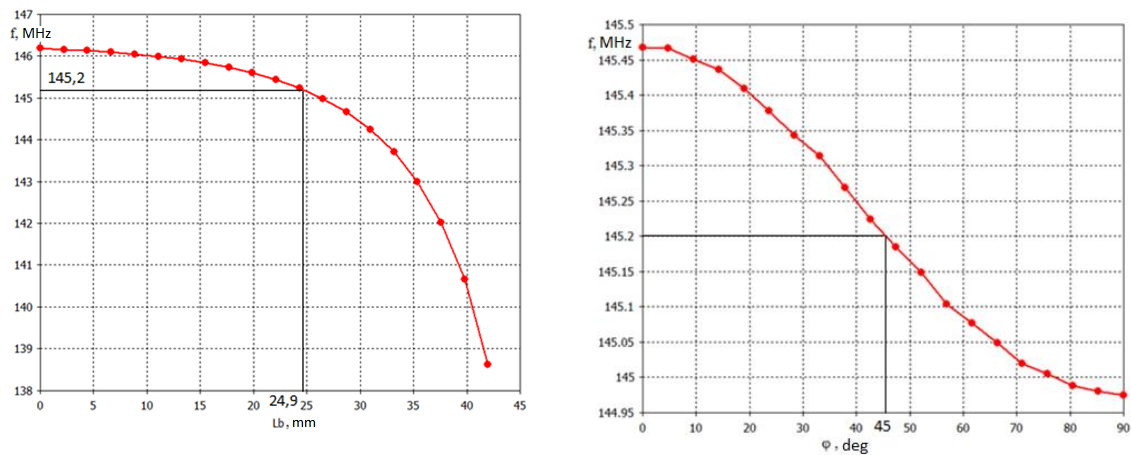

Figure 5. The dependence of buncher's resonant frequency on the manual (left) and AFC (right) plungers.

Thermal calculation is based on a numerical solution of the heat equation with given boundary and time conditions. The simulation was carried out with the following parameters (see Table 2).

Table 2. Parameters for thermal modelling.

Name	Value
Initial temperature of the environment t_0, K	293
Thermal conductivity of the environment $\lambda_{en}, \frac{W}{m \cdot K}$ (Vacuum)	0
Heat capacity of the environment $C_{en}, \frac{J}{K}$ (Vacuum)	0
Pulse duration $p, \mu s$	100

Pulse period T, s	4
Duty ratio S	40000
Peak power value W, kW	31

Modeling of the mechanical changes of the resonator geometric parameters was carried out based on the calculated temperature distribution in the structure. Since we are interested in the final deviation of resonant frequency, the deformation modeling was carried out only for the stationary state of the system, when the temperature of its parts (and hence the deformation) is maximal. It was found that the maximum value of deformation caused by temperature increase is $\Delta X = 0.0194 \text{ mm}$. This value is achieved in the region located on the drift tube.

Also, the simulation of the deformed structure resonant frequency deviation was carried. The difference between the resonance frequencies is $\Delta f_{def} = 7.78 \times 10^{-4} \text{ MHz}$. This deviation will not have a noticeable effect on the work of the buncher. Additional frequency compensation is not required.

3. Experimental test bench.

The buncher was manufactured in October 2016. Currently buncher passes the final stage of tuning and testing in the experimental test bench in ITEP. The buncher's vacuum chamber is tested at pressures close to the operating pressure of the linear accelerator LU-20. Figure 6 shows a schematic of an experimental vacuum installation. CT is a heated vacuum chamber; VA - vacuum shutter with electric drive; NR - high-vacuum pump TMN-1000; N - spiral pump PDV500; PT, PA – ionization vacuum meter VIT-2 with PMT-2 and PMI-2 lamps; G leak detector MSE-2000R; PM - magnetic vacuum meter PKR-251; VF – spill. Heating is carried out by heating tape ENTL-1, which is wrapped around a vacuum tank.

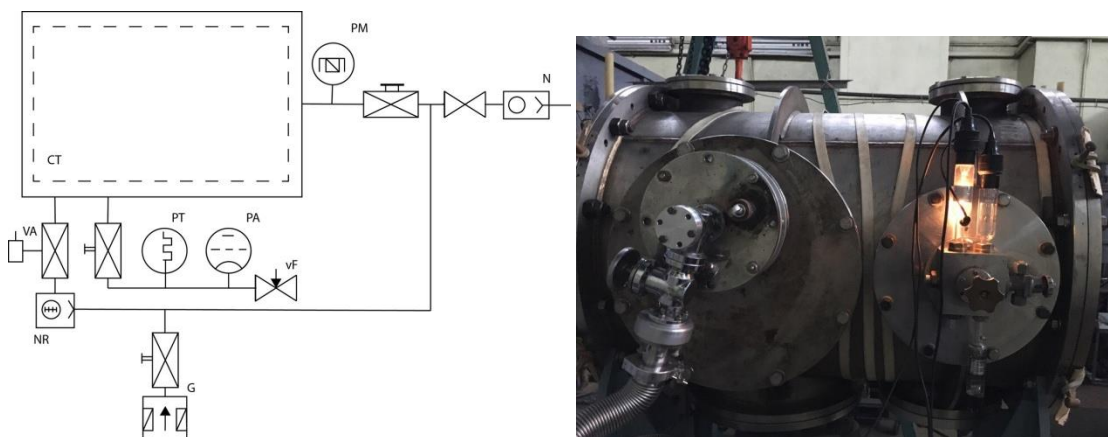

Figure 6. Vacuum test bench.

After passing of the necessary tests, the buncher will be transported to Dubna and installed in the "Injector Hall" of the "Nuclotron" Accelerator Complex.

References

- [1] Trubnikov D, Agapov N, Brovko O et al 2013 NICA project at JINR *Proc. of IPAC2013* (Shanghai) p 1343
- [2] Aleksandrov V, Butenko A, Golovenskiy B Commissioning of new proton and light ion injector for nuclotron-NICA et al 2016 *Proc. of IPAC2016* (Busan) p 941
- [3] Butenko A, Donets E, Donets E et al 2013 Development of the NICA injection facility *Proc. of IPAC2013* (Shanghai) p 3915