

Vacuum System at IUAC

A. Mandal

Inter-University Accelerator Centre, Aruna Asaf Ali Marg, Post Box - 10502, New Delhi – 110067, Fax:011-26893666.

email: mandal@iuac.res.in

Abstract: Vacuum technology is an integral part of any accelerator system. At IUAC we have a 15UD PELLETRON, superconducting LINAC, Low Energy Ion beam Facility and a 1.7MV pelletron. Vacuum requirement in these accelerators is $\sim 10^{-8}$ torr. Various types of Vacuum pump are used in different zones of the accelerators depending on load. Since the whole accelerator is quite long, distributed pumps are placed in different sections as per load. In ion sources displacement type pump viz turbo-pumps are usually used as the gas load is quite high. In other parts of the accelerator combination of getter and ion pumps are used. It is very much necessary to isolate different sections for maintenance purpose. Proper valves are used to isolate the sections and to avoid vacuum accidents proper interlock system is introduced. If air goes in some sections accidentally, valves will close automatically to protect other sections. The talk will cover different types of pumps and interlock used in accelerators at IUAC.

1.Introduction.

The vacuum system is an integral part of any particle accelerator and accelerator based research facilities. At IUAC we are having a 15UD Pelletron, superconducting LINAC and an ECR based low energy Ion beam facility. Vacuum system mainly consists of pumps, gauges for measurement of vacuum, valves for interlock and isolation of different zones and proper electronic interlock system for safe operation to avoid accidental vacuum leak. The design of vacuum system depends on the type of accelerator, high voltage used, type of ions to accelerate, volume of the system, gas load etc. For heavy ion accelerator the requirement of vacuum is $\sim 10^{-8}$ torr as the particles while moving through beam line should suffer minimum collision with residual gases present in the system. Types of pumps needed depends on the ultimate level of vacuum required, gas loading in the system etc. While designing the vacuum system, the choice of material of the chamber is very important. Utmost care and clean handling of the components is necessary during installation of the vacuum system. After installation leak checking is must to ensure the quality of installation. To measure the level of vacuum achieved proper gauges at proper places should be attached. In a big accelerator, vacuum interlock is very important to save the important system in case of accidental leakage in any part. This paper describes the vacuum design in Pelletron, LINAC and Low energy ion beam facility.

2.Pelletron

15UD Pelletron is a vertical Tandem accelerator having terminal voltage 16 MV supplied by National Electrostatic corporation (NEC), USA. The system is divided into several zones. A schematic diagram of the pelletron is shown in figure1. It has following zones: Ion source at the top where different negative ions are produced using SNICS ion source. The ions produced are pre-accelerated upto 300

kV and mass analysed by a dipole magnet. The analysed ions are then injected into Tandem accelerator column which are kept in large tank filled with SF₆ gas at high pressure. The details of system are described elsewhere [1]. The terminal voltage of the pelletron is 16MV. After passing through terminal the ions are passed through a gas stripper or foil stripper to convert into positive ions which are further accelerated downwards. The total energy achieved is $(q+1)V$ where q is the charge state and V is terminal voltage. A big dipole magnet at the bottom analyses the ion of particular energy and finally transported to target in the experimental area in the beam hall downstream. The total system is ~ 100 meters.

2.1. Design of the vacuum system of Pelletron

In the 15UD PELLETRON Tandem Accelerator the ultra high vacuum (UHV) condition is maintained throughout the pre-accelerating, accelerating and post accelerating system and seven beam lines spanning over a length of more than 100 meters. The vacuum system is exposed to simple ambient pressure (1bar) as well as upto 8 bar SF₆ environment. The simplified view of the system is given in Fig 1. The system is designed keeping in mind the requirements of the distributed pumping stations taking care of conductance limitation of such a huge vacuum system. The pumps are controlled from the remote control using a computer and CAMAC highway.

All the pumps run in fully automated interlocked mode in a fail-safe condition. In case of any power failure no human interference is needed and the interlock system takes care of isolating the vacuum areas from venting and all the pumps are shut down. Within a few seconds our captive power is automatically put on to maintain the UHV vacuum level inside the accelerator by keeping the Ion Pump and Getter pumps on. It helps in restarting the accelerator immediately when the normal power is restored. In absence of the captive power the vacuum level would have deteriorated and it would have taken a couple of hours more to restore the UHV condition. With the interlocks, whole system is protected against any vacuum failure or accidental venting of the experimental chambers without closing valve before it.

In case of any vacuum accident the signal of rise in pressure above on pre-selected level is transmitted to various interlocked electro-pneumatically actuated vacuum valves and spring loaded fast acting valves to isolate the other vacuum regions. The individual sections of the vacuum system are isolated and the main accelerating region inside the high pressure (8 bar SF₆) accelerator tank is totally isolated and maintained in UHV condition.

2.2 Types of vacuum valves and interlocks used in system

Manually actuated all metal right angle valve (NEC model VR1.5M) installed at all pumping ports for creating rough vacuum and leak checking of different beam line components. Two NEC manual all metal straight through valves (model VS2M) BLV T1 and BLV T2 are installed inside terminal for isolating terminal from accelerating tube during foil stripper replacement. The NEC all metal pneumatic straight through valves(model VS2P) are installed all over beam line for isolating different sections . Closing time of valve is approximately 100 milliseconds.

BLV 01-1

BLV 02-2 ----- All metal Pneumatic Straight Through Valves.

BLV 04-1

Two high speed, spring actuated, all metal fast acting straight through valves are installed tank top and bottom side of accelerator for emergency closing in case of catastrophic failure of ultra high vacuum system. The fast valves are actuated by NEC coaxial pressure sensor (model CPS2.) and closing time of valve is approximately 35 milliseconds.

BLV 02-1 --- All metal Fast acting valves , closing by spring.

BLV 03-2

High pressure, pneumatically operated pendulum valves (BLV02-2 & BLV03-1) are installed on both sides of the accelerator for avoiding the loss of SF₆ gas in case of any major breakdown of the seal between high pressure SF₆ gas environment and UHV inside the accelerating tube.

The fast closing system protects only one vacuum line at a time. At IUAC, we have seven beam lines so one sensor was placed in each of the beam lines near experimental chamber and a multiplexer was incorporated into the fast closing system. At the time of experiment, the sensor of the active beam line is selected through the multiplexer and the Fast closing valve is interlocked with the selected sensor.

2.3 Types of vacuum pump used in system

Turbo Pump :Two turbo molecular pump (TP 01-1 & 02)of capacity 1500 l/s are installed before injector magnet for maintaining ultra high vacuum (~ 10⁻⁹ torr) through displacement of pressure load from ion source. Ion gauge controller IGC 01-1 and IGC 01-2 monitors vacuum near the ion source. Two turbo molecular pumps have been installed inside terminal (TP-T1 and TP-T2) for recirculating the gas to achieve better efficiency of gas stripper.

Getter Pump: The NEC air cooled titanium sublimation pump are used in different pumping location in combination with ion pump. Getter pump is effective upto pressure 1.0 X 10⁻⁶ torr to absorb active gases viz. oxygen and nitrogen. An array of six TS20 sublimator cartridge are used with special feed through flanged for long operation life time

Ion Pump : To maintain ultra high vacuum throughout pelletron accelerator and beam lines several D-I ion pump (Physical Electronics make) of different capacity are used. Ion pumps helps to remove the inert gases presents in the system. The combination of getter and ion pump helps to achieve vacuum of the order of 1.0 X 10⁻⁹ Torr . The pumping capacity of different ion pumps are given bellow.

IP 02-1 -- 80 l/s,, IP 02-1a -- 220 l/s, IP 04-1 -- 80 l/s ,
 IP 03-2 -- 80 l/s,, IP 02- -- 400 l/s, IP 03-1 -- 400 l/s,

2.4 Types of vacuum gauge used in system

Conventional pirani gauges are used for measuring backing pressure of turbo molecular pump TP 01-1 and TP 01-2. Hot cathode ionization gauges are used for measuring high vacuum after ion source area using IGC 01-1 , IGC 01-2, pre and post accelerator section using IGC 02-1 and IGC 03-1. In rest of the area vacuum is measured calibrating ion pump current. Typical vacuum obtained at various locations are given in table1 .

Table 1. Ion gauge readings at different locations

Location	Pressure (Torr)	Location	Pressure (Torr)	Location	Pressure (Torr)
<i>IGC 01-1</i>	< 1.0 X 10 ⁻⁸	IP 02-2	< 1.0 X 10 ⁻⁹	IP T2	< 2.0 X 10 ⁻⁸
<i>IGC 01-2</i>	< 1.0 X 10 ⁻⁸	IGC 02-1	< 1.0 X 10 ⁻⁸	IP D2	< 5.0 X 10 ⁻⁹
IP 02-1	< 1.0 X 10 ⁻⁹	IP D1	< 5.0 X 10 ⁻⁹	IP 03-1	< 1.0 X 10 ⁻⁹
IP 02-1a	< 2.0 X 10 ⁻⁹	IP T1	< 1.0 X 10 ⁻⁸	IGC 03-1	< 1.0 X 10 ⁻⁸
		IP 03-2	< 1.0 X 10 ⁻⁹	IP 04-1	< 1.0 X 10 ⁻⁹

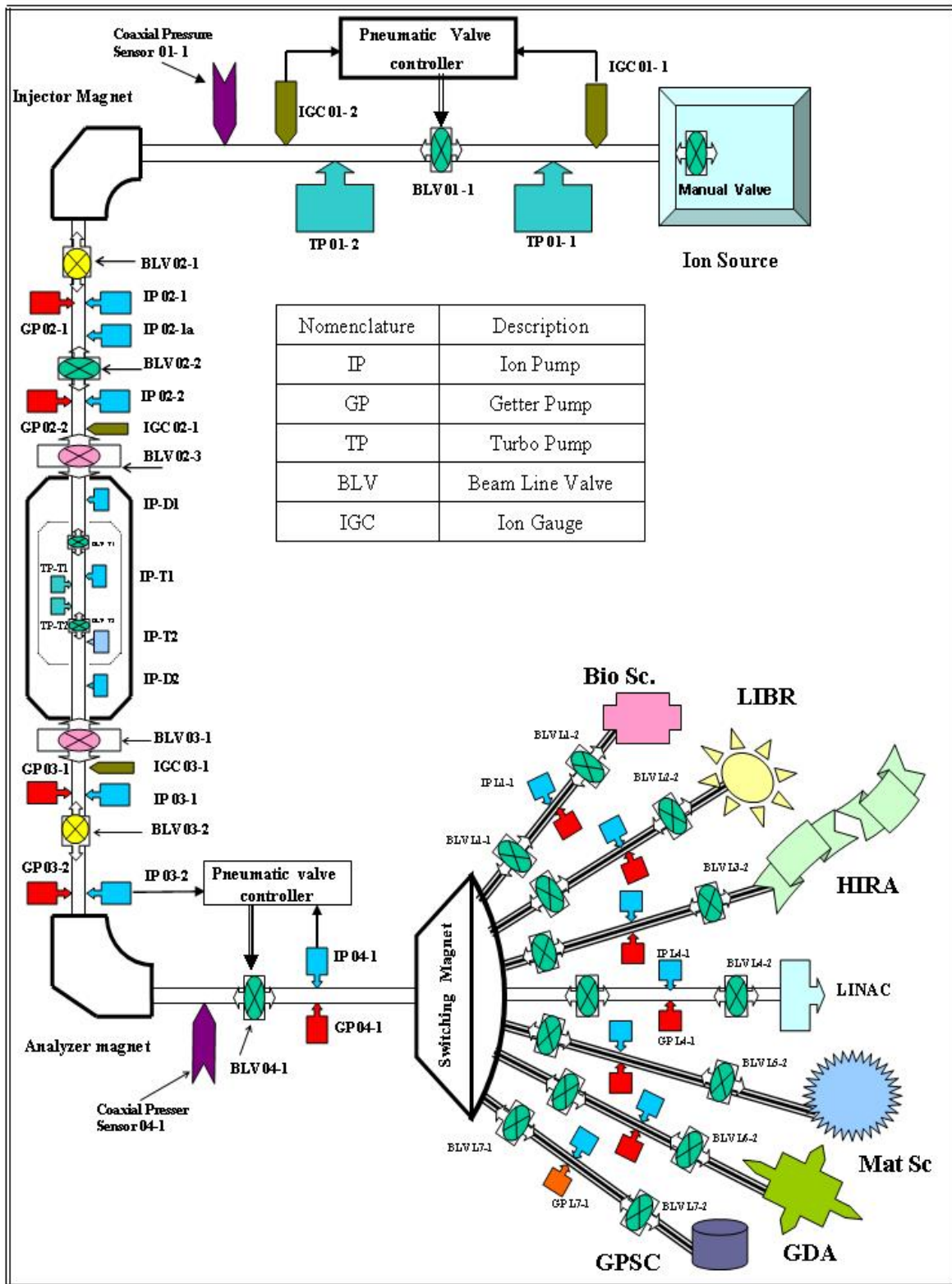

Fig.1. Schematic of vacuum system for pelletron.

3. Linear Accelerator (LINAC)

The zero degree beam line of Pelletron has been extended to LINAC. The bunched (~ns) beam from Pelletron is further bunched (~100ps) by a super conducting quarter wave resonator (QWR) and then injected into LINAC for further acceleration. The LINAC consists of three cryostats. Each cryostat has eight quarter wave resonators. The details are described elsewhere[2]. The accelerated ions from LINAC are re-bunched by two QWRs and then switched into four beam lines in BH-II. The whole LINAC system is shown in figure2.

3.1 Vacuum design of LINAC

The distributed vacuum system for the LINAC is shown in figure [2]. The philosophy of vacuum system is similar to pelletron vacuum system. Each linac cryostat is evacuated by turbo pump of capacity 2300 lps backed by dry scroll pump (Edwards 30 m³/hr). The beam lines are having distributed ION-getter pump combination similar to pelletron vacuum system.

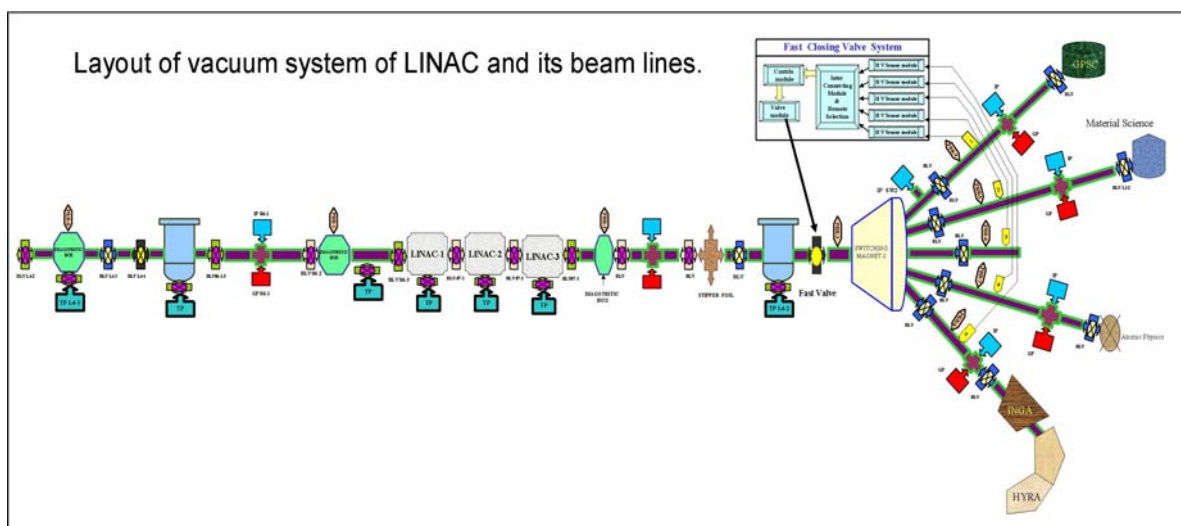

Fig. 2. Schematic of vacuum system for LINAC.

4. Low Energy Ion Beam Facility (LEIBF)

An ECR based LEIBF has been installed in new material science building for atomic -molecular physics and material sciences study. The accelerator consists of an ECR ion source, 400 kV accelerating column and an analyzing -cum switching magnet with three beam ports at 75, 90 and 105 degrees. It provides ions ranging from a few keV to a few MeV. Details of the system described elsewhere [3].

4.1 Vacuum system of LEIBF

In the ECR ion source region the gas load is quite high. A turbo pump having pumping speed of 500 lps on high voltage deck just after the ion source to maintain a vacuum ~10⁻⁶ torr. After the deck a 1000 lps turbo pump is used to maintain vacuum of the order of < 1.0 X 10⁻⁸ torr inside accelerating tube. In the beam line ion-getter combination is used to achieve a vacuum 1.0 X 10⁻⁹ torr. The layout of the whole system along with the vacuum system is shown in figure3. The whole system was leak tested using helium leak detectors before activating the pumps.

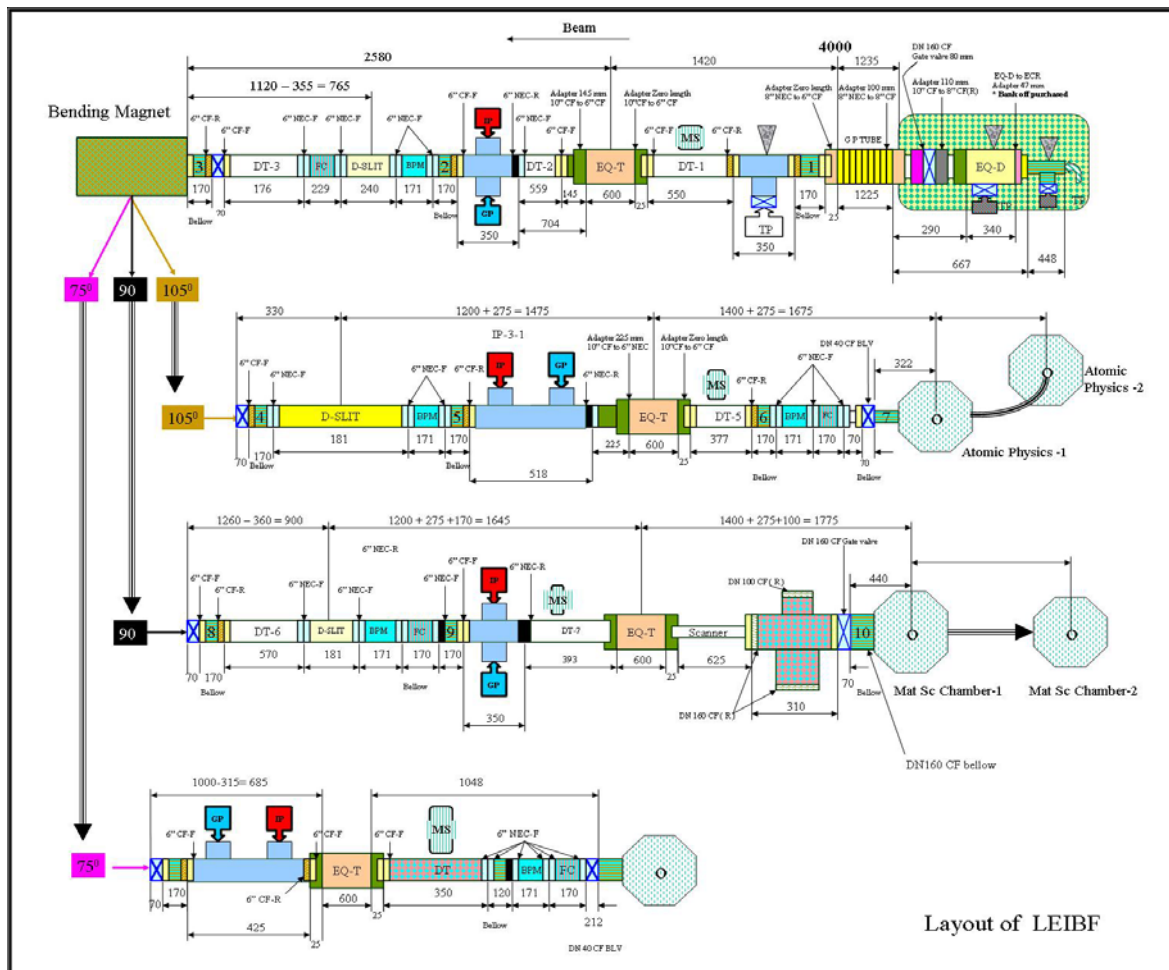

Fig.3. Layout of vacuum system for LEIBF.

Acknowledgement

The author acknowledges the contributions received from P. Barua and A. Kothari of vacuum group for design of vacuum system at IUAC..

References

- [1] D.Kanjilal, S.Chopra, M.M.Narayanan, Indira S Iyer, Vandana Jha, R.Joshi and S.K.Dutta. Nucl. Instr and Meth, A 328(1993)97
- [2] A.Roy, Curr. Sci.76(1999)149
- [3] Abanimohan Mandal, Dinakar Kanjilal, Sarvesh Kumar, G.O. Rodrigues, IPAC2011, Spain.