

PREPARED FOR SUBMISSION TO JINST

16TH TOPICAL SEMINAR ON INNOVATIVE PARTICLE AND RADIATION DETECTORS (IPRD23)
25-29 SEPTEMBER 2023
SIENA, ITALY

Time calibration and synchronization of the scintillation light detection system in ICARUS-T600

**G.L. Raselli,^{a,1} B. Behera,^b R. Benocci,^c M. Bonesini,^c S. Copello,^a M. Diwan,^d
A. Menegolli,^{a,e} G. Petrillo,^f M.C. Prata,^a M. Rossella,^a D. Torretta,^g M. Vicenzi^d on
behalf of the Icarus collaboration**

^a*INFN Sezione di Pavia, Via A. Bassi 6, Pavia 27100, Italy*

^b*Department of Physics, University of Florida, 2001 Museum Rd, Gainesville, FL 32611, USA*

^c*INFN Sezione di Milano Bicocca and University of Milano Bicocca, Piazza della Scienza 3, Milan 20126, Italy*

^d*Brookhaven National Lab (BNL), Upton, NY 11973, USA*

^e*Department of Physics, University of Pavia, Via A. Bassi 6, 27100 Pavia 27100, Italy*

^f*Stanford National Acceleratory Laboratory (SLAC), Menlo Park, CA 94025, USA*

^g*Fermi National Accelerator Laboratory (FNAL), Batavia, IL 60510, USA*

E-mail: gianluca.raselli@pv.infn.it

ABSTRACT: The ICARUS-T600 Liquid Argon (LAr) Time Projection Chamber (TPC) is presently taking data in the Short Baseline Neutrino (SBN) program at Fermilab (USA) to search for a possible LSND-like sterile neutrino signal at $\Delta m^2 \approx 1 \text{ eV}^2$ with the Booster Neutrino Beam (BNB). A light detection system, based on 360 large area Photo-Multiplier Tubes (PMTs), has been realized for ICARUS-T600 to detect VUV photons produced by the passage of ionizing particles in LAr. This system is fundamental for the TPC operation, providing an efficient trigger and contributing to the 3D reconstruction of events. Moreover, since the detector is exposed to a huge flux of cosmic rays due to its shallow depths installation, the light detection system allows for the time reconstruction of events, contributing to the identification and to the selection of genuine neutrino interactions. The correct time reconstruction of events requires the precise knowledge of the delay of each PMT channel and a good synchronization of recording electronics, this last based on fast sampling digitizers. To achieve a time resolution better than 1 ns, we perform three consecutive timing corrections deployed at different stages of the optical data flow. Results demonstrate the capability of the ICARUS-T600 light detection system to allow a precise reconstruction of the temporal evolution of each event occurring in the detector and the association of neutrino events with the bunched structure of BNB.

KEYWORDS: Neutrino detectors; Time projection chambers (TPC); Noble liquid detectors (scintillation, ionization, double-phase)

¹Corresponding author.

Contents

1	Introduction	1
2	The ICARUS T600 scintillation light detection system	1
3	Time calibration and synchronization	2
3.1	Hardware-trigger correction	3
3.2	Laser correction	3
3.3	Cosmic rays correction	4
4	Results	6

1 Introduction

The Short Baseline Neutrino (SBN) program is a short-baseline neutrino oscillation experiment to definitely prove or exclude the existence of non-standard neutrino oscillations into sterile states at the $\Delta m^2 \approx 1 \text{ eV}^2$ mass range [1]. It consists of Liquid Argon Time Projection Chamber (LAr-TPC) detectors deployed along the Booster Neutrino Beam-line (BNB) at Fermilab. ICARUS-T600 is operating as far detector, placed at 600 m from the neutrino source, while SBND will act as near detector, at 110 m from the neutrino source [1].

ICARUS-T600 is taking data from 2019 at shallow depth, exposed to the huge cosmic background which can mimic genuine ν_e interactions [2]. Therefore it is fundamental to distinguish signals related to the neutrino beam from those induced by cosmic rays. The prompt signals from the LAr scintillation can be exploited to follow the time development of interaction in the detector, contributing to the identification and to the selection of genuine neutrino interactions. To this purpose a time calibrated detection system with a resolution better than 1 ns is required.

2 The ICARUS T600 scintillation light detection system

ICARUS-T600 consists of two identical cryostats, each housing two TPCs with a common cathode. Charged particles interacting in liquid argon produce both scintillation light ($\lambda = 128 \text{ nm}$) and ionization electrons. Electrons are drifted by an electric field ($E = 500 \text{ V/cm}$) to the anode, made of three parallel wire planes. Photons are detected by a light detection system based on 360 Hamamatsu R5912-MOD 8" PMTs mounted behind the wire planes [3]. Each device is made sensitive to vacuum ultraviolet (VUV) photons thanks to a $200 \mu\text{g/cm}^2$ tetraphenyl butadiene coating deposited on the sensitive windows by means of a thermal evaporation [4].

PMT electronics is designed to allow continuous read-out, digitization and independent waveform recording of signals coming from the 360 PMTs. This operation is accomplished by 24

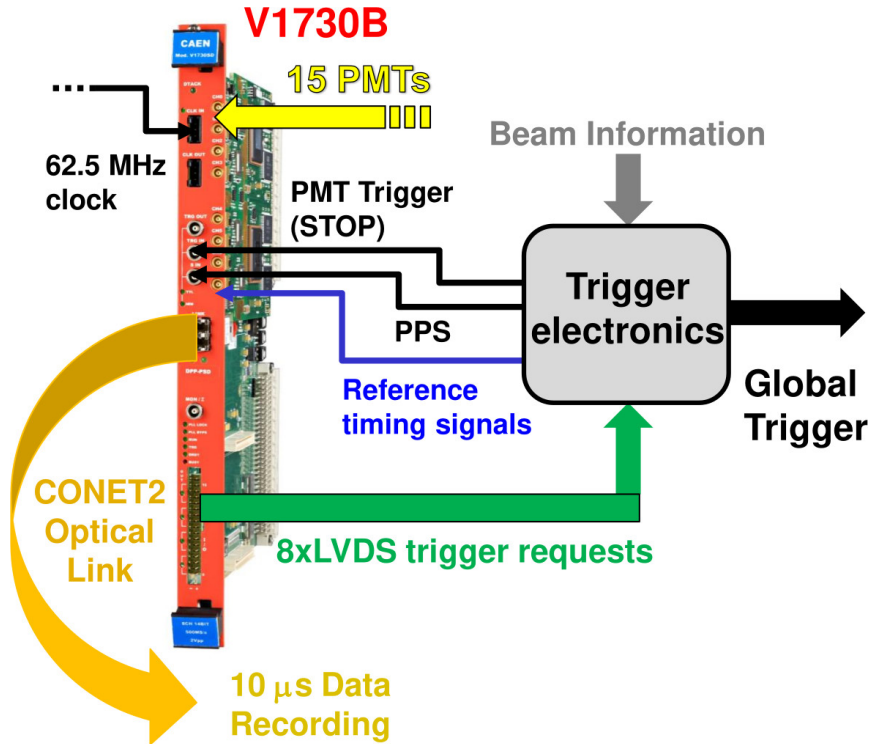

Figure 1. Conceptual diagram showing the application of a V1730B digitizer into the PMT electronics.

digitizers (CAEN V1730B). A conceptual diagram showing the application of a V1730B digitizer into the PMT electronics is presented in figure 1.

Each board consists of a 16-channel 14-bit 500-MSa/s FLASH ADC with 2 V_{pp} input dynamic range. In each board 15 channels are used for the acquisition of PMT signals, while a channel is left for the acquisition of reference timing signals, as described section 3.

For each channel 1024 consecutive buffers are available for data recording, each with a memory depth of 5 kSa, corresponding to 10 μs for a 2 ns sampling time. During the acquisition, data stream of each channel is circularly written in the first available buffer. When a board receives an external trigger pulse (STOP), the active buffers are frozen, writing operations are moved to the next available buffers and stored data are read out through dedicated CONET2 optical links.

V1730B boards generate trigger-request logical patterns through Low Voltage Differential Signal (LVDS) outputs showing the presence of signals with amplitude exceeding digitally programmed thresholds. LVDS signals are processed by the trigger electronics to activate the PMT waveform recording and to generate a detector Global Trigger signal when an interaction occurs inside a beam gate.

3 Time calibration and synchronization

The correct identification and selection of neutrino events requires the precise time reconstruction of each interaction inside the detector. To achieve a time resolution better than 1 ns, we perform three consecutive timing corrections deployed at different stages of the optical data flow:

1. Hardware-trigger correction: to reduce the intrinsic 16 ns temporal uncertainty of the CAEN V1730B digitizers;
2. Laser correction: to cancel PMT transit time differences and readout delays;
3. Cosmic rays correction: to perform a fine equalization of the PMT response times using downward-going cosmic muons.

In the following an overview of all three items is presented.

3.1 Hardware-trigger correction

PMT signals are recorded in buffers of 5 kSa, corresponding to temporal fragments of 10 μ s, adjusted around the trigger time. At the end of the buffer a timestamp (TTT = Trigger Time Tag), read from a 62.5 MHz 31-bit time counter is assigned by each digitizer. A GPS PPS (Pulse Per Second) signal is sent to each digitizer by the trigger electronics to perform every second a synchronized reset of all the TTT counters (see figure 1). In this way data are aligned and coherent across the multi-board system, even if the reconstruction of the absolute time of the PMT signals is affected by a 16 ns uncertainty, due to the time counter resolution.

To reduce this internal temporal uncertainty, additional signals, to be used as a time reference, are recorded for each event in dedicated channels every 3 boards, as shown in figure 2. Namely: 1) a copy of the pulse that has triggered the signal recording (STOP); 2) the Early Warning (EW) of an incoming beam spill sent by the accelerator complex; 3) the Resistive Wall Monitors (RWM) signal, matched with the actual arrival time of proton extraction at the beam target.

The availability of a copy of the trigger signal digitized with the same electronics allows the reassignment of the time of each PMT with respect to the trigger time within the sampling precision (2 ns). In addition, the presence of the leading edge of the beam gate and the RWM signal, allows the temporal positioning of the event inside the beam spill.

3.2 Laser correction

The temporal reconstruction of an event requires the precise determination of internal delays, which may differ channel by channel due to different transit time of PMTs and other read-out delays, such as cable delays that may drift for temperature excursions.

Internal delays are determined by delivering fast calibration light pulses to each individual channel. To this purpose a fast-laser based calibration system was developed. Laser pulses ($\lambda = 405$ nm, FWHM = 60 ps) are generated by a laser diode head (Hamamatsu PLP10) and then sent to each PMT window by means of a light distribution system based on optical fibers, light splitters and optical feed-through flanges [5].

During calibration, dedicated data runs are taken by illuminating all the 360 PMTs at the same time and recording response to 10 Hz laser pulses. The simultaneous recording allows to evaluate the time differences among the channels and the definition of a correction table.

As an example, in figure 3 for each PMT the delay with respect to the trigger pulse is shown as a function of the supply voltage, which mainly affects the internal transit time.

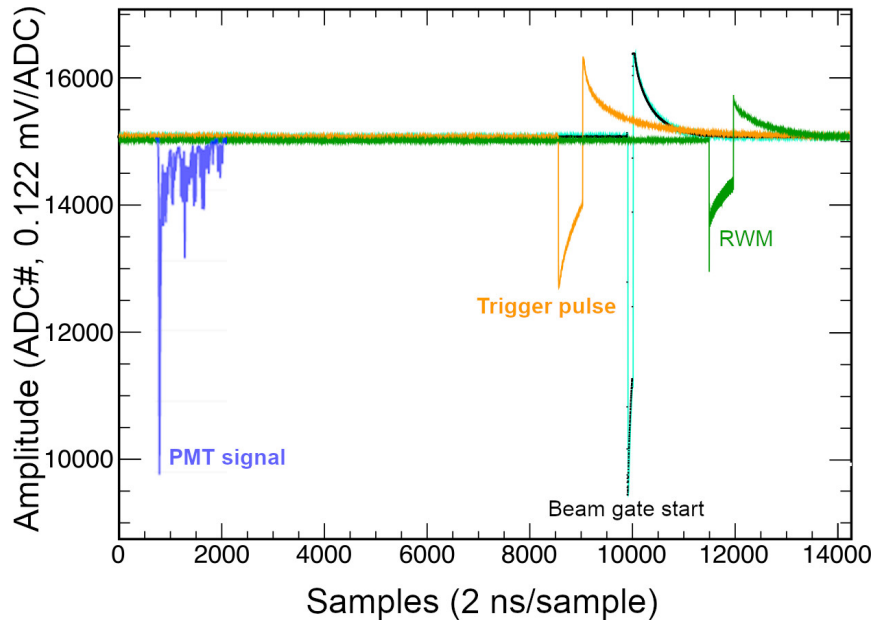

Figure 2. Picture showing a PMT signal together with the time reference pulses. The mutual delays allow the reassignment of the time of each PMT signal with respect to the trigger and beam spill times within the digitizer sampling precision (2 ns).

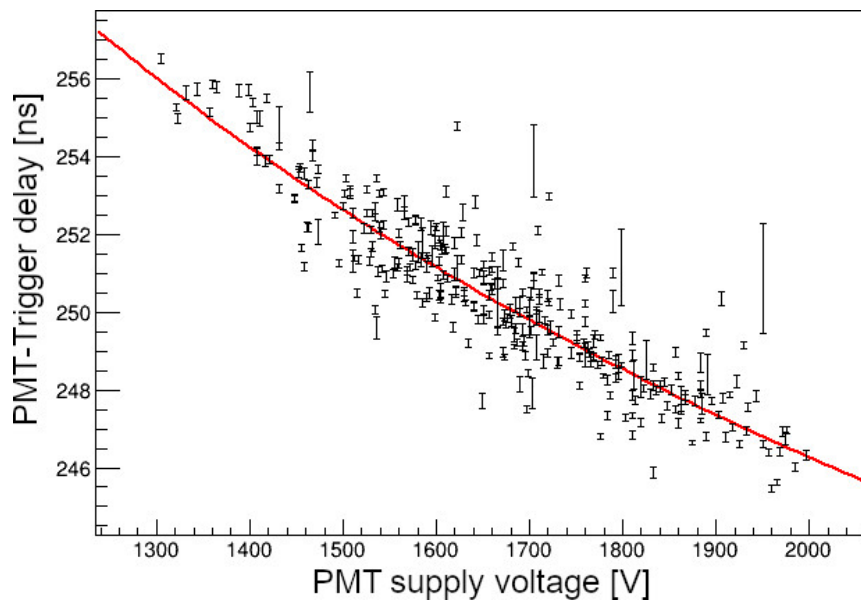

Figure 3. Plot of the PMT delays with respect to the trigger pulse as a function of the supply voltage. Delays are dominated by PMT transit times which follow a power law of the supply voltages.

3.3 Cosmic rays correction

A further improvement in the temporal reconstruction of each PMT signal is achieved performing an additional correction by comparing the expected arrival time of photons on the surface of the PMTs using actual downward-going cosmic muons.

To this purpose, a set of downward-going cosmic muons, crossing almost vertically the entire sensitive volume of the detector, is selected. For each muons, an analysis is performed to extract the arrival time of the first photon on the surface of the PMTs facing the muon track, as graphically shown in figure 4. For each group of PMTs mounted at the same same height and facing the muon track, a mean response time is calculated and plotted as a function of the vertical coordinate (Y) as shown in figure 5. The expected linear relation between time and the vertical position for downward-going muons is estimated by fitting the mean response time as a function of the PMT quota. After that, any deviation gives rise to a residual value which is used to perform a fine correction of the time response of the affected PMTs.

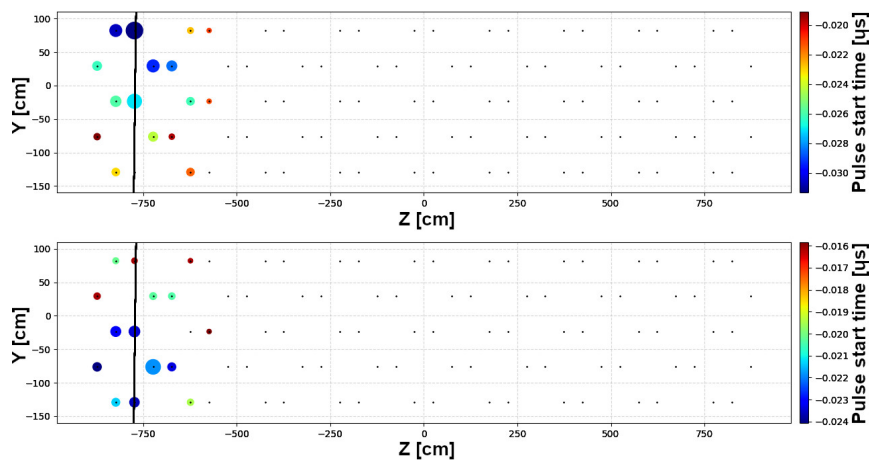

Figure 4. Graphic representation of a cosmic ray passing through the detector and seen by the two facing PMTs walls. The arrival times and and the number of photons to the surface of each PMT are coded through the color and size of the light spot.

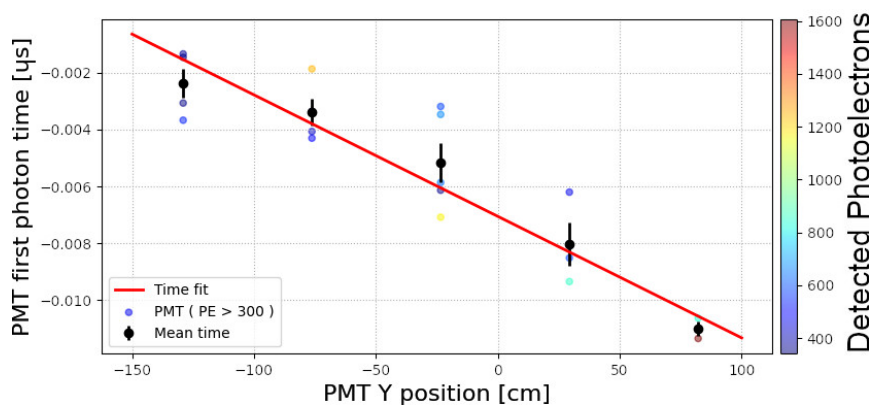

Figure 5. Picture showing the PMT mean response time as a function of the PMT vertical coordinate (Y). Data are fitted with a linear relation and any deviation from the fitted straight line gives rise to a residual value used for time correction.

4 Results

To point out the timing improvements attainable in each correction step, we use an independent set of downward-going cosmic muons and perform an analysis similar to the one carried out during the cosmic rays correction.

Figure 6 shows the distribution of the residuals resulting after the implementation of each timing correction. The distribution of residuals after the hardware-trigger correction shows a large spread of values ($\sigma \approx 2$ ns), being dominated by the extension of the delay differences among the PMT channels. The laser correction reduces the time spread to $\sigma \approx 1$ ns. The final cosmic rays correction allows to achieve precision better than 1 ns, actually $\sigma \approx 300$ ps.

This latest result demonstrates the capability of the ICARUS-T600 light detection system to allow a precise reconstruction of the temporal evolution of every event that occurs in the detector. This characteristic allows the selection of tracks coming from outside the detector (cosmic muons) from those associated with the interactions that occur in the sensitive volume (neutrino interactions) using the light information alone.

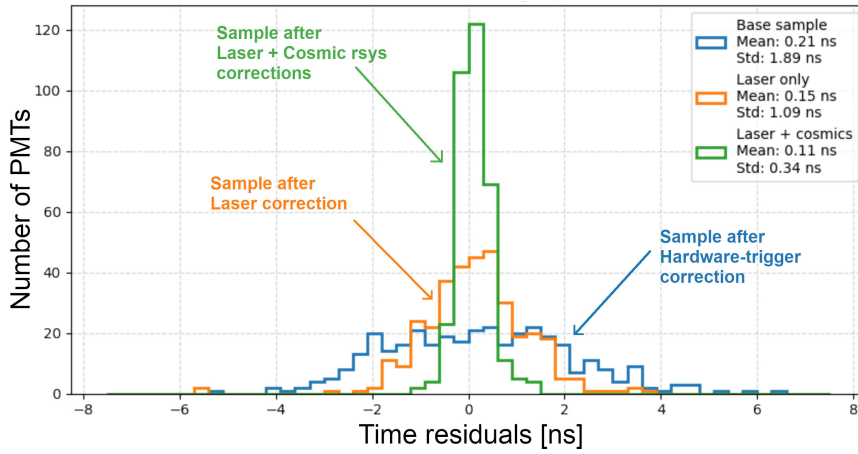

Figure 6. Distribution of the residuals resulting after the implementation of each timing corrections.

Acknowledgments

This work was supported by the EU Horizon 2020 Research and Innovation Program under the Marie Skłodowska-Curie Grant Agreement No. 734303, 822185, 858199, 101003460 and 101081478.

References

- [1] SBN Collaboration, *A proposal for a three detector short-baseline neutrino oscillation program in the Fermilab Booster Neutrino Beam*, FNAL Proposal P-105, arxiv:1503.01520.
- [2] P. Abratenko et al (ICARUS Collaboration), *ICARUS at the Fermilab Short-Baseline Neutrino program: initial operation*, *Eur. Phys. J. C* (2023) 83:467.
- [3] B. Ali-Mohammadzadeh et al. (ICARUS Collaboration), *Design and implementation of the new scintillation light detection system of ICARUS T600*, *JINST* 15, (2020) T10007

- [4] M. Bonesini et al., *An innovative technique for TPB deposition on convex window photomultiplier tubes*, *JINST 13*, (2018) P12020
- [5] M. Bonesini et al. (ICARUS Collaboration), *The laser diode calibration system of the ICARUS T600 detector at FNAL*, *JINST 15*, (2020) C05042