

CONCEPTUAL DESIGN OF VACUUM CHAMBER FOR SPS-II STORAGE RING

T. Phimsen[†], N. Juntong, S. Chaichuay, S. Prawanta, P. Sunwong, P. Sudmuang, P. Klysubun
Synchrotron Light Research Institute, Nakhon Ratchasima, Thailand
R. Deepan, A. Khamkham, Suranaree University of Technology, Nakhon Ratchasima, Thailand

Abstract

The SPS-II is a 3 GeV ultralow emittance light source which is now under studied and designed by Thailand Synchrotron Light Research Institute (SLRI). The SPS-II storage ring is based on Double-Triple Bend Achromat (DTBA) cell with a circumference of 321.3 m aiming for horizontal emittance of less than 1 nm-rad. The compact lattice leaves narrow space for vacuum components. The small gap between poles of the magnets requires narrow vacuum chambers and limits the conductance of the chambers. The chambers will be made by stainless steel with a thickness of 1.5 mm. the cross section of beam duct is 40 mm × 16 mm elliptical shape. The bending chamber is designed as a long triangular chamber such that photon absorber can be installed as far from the light source as possible to lower the power density of the heat load. The overview of designed vacuum system for the SPS-II is presented.

INTRODUCTION

The SPS-II is Thailand's 3 GeV ultra-low emittance light source project which is now under studied and designed by Thailand Synchrotron Light Research Institute (SLRI). The SPS-II storage ring is based on the Double-Triple Bend Achromat cell consisting of 14 DTBA cells (22.95 m/cell), which adds up to 321.3 m total ring circumference [1]. Figure 1 displays the DTBA lattice cell which comprises 4 normal dipole magnets (B1, B2, B5, and B6), 2 combined functions dipole magnets (B3 and B4), 16 quadrupole magnets, 6 sextupole magnets, and 2 octupole magnets. The design horizontal emittance is less than 1 nm-rad.

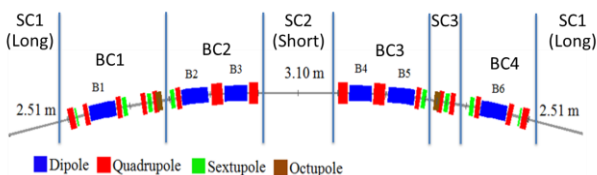

Figure 1: Schematic diagram of SPS-II DTBA cell and sectioned-vacuum chamber.

Considering local manufactured technology and a very small thickness of the chamber caused by narrow gaps between magnet poles, the chambers were firstly designed using stainless steel. However, recently there is a consideration to change the chamber material to aluminium alloy owing to simplicity of overall fabrication process to achieve the low impedance storage ring.

In this report, the conceptual design of stainless steel chamber will be described. Finally, the preliminary study on deformation of aluminium chamber will be reported.

VACUUM CHAMBERS

Vacuum chamber design will be based on the TPS vacuum chambers [2]. The design divides the DTBA unit cell into 7 sections as displayed in Fig. 1. It is preferable to have the vacuum chamber with the same cross-section around the storage ring although the beam stay-clear (BSC) value varies. In the preliminary magnet design [3-4], the horizontal BSC of ± 20 mm and the vertical BSC of ± 8 mm (maximum values) are implemented.

The DTBA lattice affects the design of the vacuum system significantly. The arrangement of many multi-pole magnets causes severe space constraints. In addition, the strong focusing magnets require a very small chamber, which results in low vacuum conductance. The design aims to use only non-evaporable getter (NEG) cartridges and sputter ion pumps (SIP) to obtain the required pressure. Therefore, the chamber surface should be treated to be as clean as possible for reducing the residual gas from both static and dynamic outgassing.

For stable vacuum system, the fabrication tolerances of vacuum chambers and components should be less than ± 0.3 mm and ± 0.1 mm for general conditions and high-precision components (e.g. beam duct), respectively.

The gap between multi-pole magnets leaves the chamber thickness of only 1.5 mm. Because of this limitation of the chamber thickness, the mechanical strength should be concerned. Stainless steel, in the first place, was selected as chamber material due to its excellent strength.

Bending Section

The bending chamber is designed as a long triangular chamber such that photon absorber can be installed as far from the light source as possible to lower the power density

* Work supported by Ministry of Higher Education, Science, Research and Innovation (MHESI)

[†] thanapong@slri.or.th

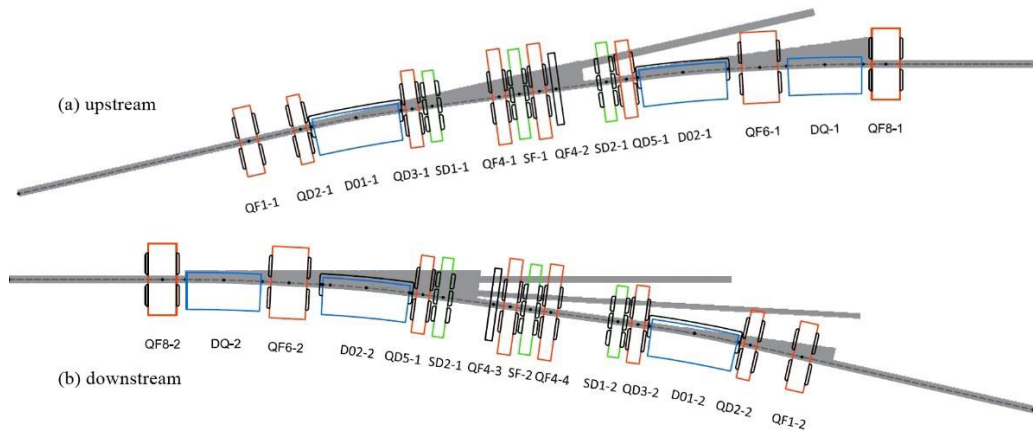

Figure 2: Top-view layout of the upstream (a) and downstream (b) chambers inside the DTBA cell magnets.

of the heat load on the crotch absorbers located downstream in the antechamber. Vacuum pumps should be located near the photon absorbers to evacuate emitted gas from Photon-Stimulated Desorption (PSD) and to prevent the amount of gas flowing back to the beam duct. Moreover, the design idea of using a large bending chamber will benefit from lower impedance of the chamber structure achieved by reducing the quantity of tapers, flange gaps, pumping holes, and bellows.

The vacuum chambers in the bending sections, called BC1, BC2, BC3, and BC4, must be designed to fit the apertures of the adjacent magnets as seen in Fig. 1 and Fig. 2. Each unit cell will have all four bending chambers, so the storage ring has in total 14 of BC1, BC2, BC3, and BC4.

The cross section of the standard chambers is elliptical with the vertical inner diameter of 16 mm and the horizontal diameter of 40 mm. The open aperture between the antechamber, for extracting the photon beam and installing the pumps, and the beam duct, is 7 mm height. The clearance between the chamber and the magnet is 1 mm typically. Chamber cross-section inside the magnets can be seen in Fig. 3.

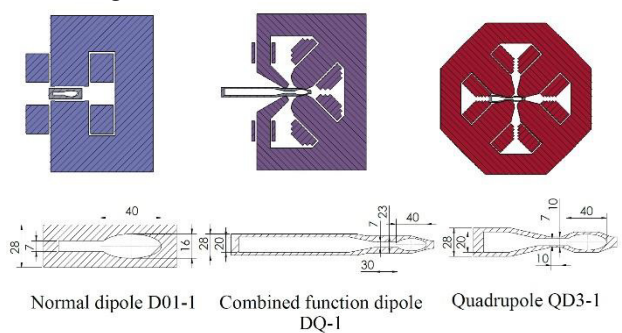

Figure 3: Cross-section of stainless steel vacuum chamber inside magnets. The machining and positioning of the bending chamber must be precise for not to conflict with the active components nearby.

Straight Section

There are three types of vacuum chamber for the straight sections: 14 long straight (SC1) sections, 14 short straight (SC2) sections, and 14 straight sections for quadrupole, sextupole and octupole (SC3) as shown in Fig. 1.

The cross section of the straight section chamber is also elliptical shape with the same dimensions as the beam duct of bending chambers. The thickness of chambers is 1.5 mm. The chamber will be fabricated from stainless steel with two cooling channels on both sides.

The taper chambers will be used invariably to accommodate adjacent chambers that have different cross sections. The chambers for insertion devices are designed to meet their ID chambers specifications. However, not all insertion devices chambers will be installed in the straight sections during the commissioning of the storage ring. Dummy chambers made from stainless steel will be installed in the SC1 and SC2 sections instead of insertion devices. Dummy chambers cross sections are illustrated in Fig. 4.

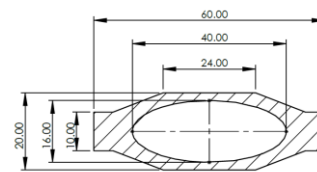

Figure 4: Cross-section of vacuum chambers in straight sections.

Preliminary Study on Deformation of Aluminum Chamber

To decrease the impedance of the stainless steel chamber, the beam duct should be coated or plated with material having high electrical conductance such as silver or copper. Moreover, the vacuum firing at 950 °C for 1 hour is needed to remove hydrogen from the bulk material and to reduce hydrogen outgassing rate. These make the complicated fabrication processes.

Content from this work may be used under the terms of the CC BY 3.0 licence (© 2019). Any distribution of this work must maintain attribution to the author(s), title of the work, publisher, and DOI

The unbaked aluminium normally has higher outgassing than stainless steel, but with a treatment of ethanol machining and ozonated water cleaning the outgassing can be lower than that of stainless steel[5-6]. The high thermal conductivity of aluminium offers distinct advantages over stainless steel, both during the in-situ bake and during normal operation. No conductive coatings or strips are needed on aluminium to reduce the chamber wall impedance. For these reasons, we recently have decided to change the material of the chamber to aluminium.

The main concerning problem is that if the deformation of the chambers due to the evacuation is acceptable, especially with the locations where the chamber thickness is 1.5 mm.

Considering aluminium chamber fabrication and mechanical strength, the chamber design has been improved by increasing the thickness of chamber (from top to bottom) to be 100 mm as demonstrated in Figure 5. The outside of the chamber will be machined to fit the shapes of poles and coils for the multipole magnets along the beam duct. The inside chamber cross section is same as the design of previous stainless steel chambers, and it will be machined the channels for the electron beam duct and the photon duct.

The deformation of the bending chamber BC1 made of A6061T5 was simulated using ANSYS program. The result is shown in Fig. 6. The maximum deformation exhibits 0.06 mm around the region inside quadrupole and sextupole magnets, while less than 0.05 mm at the beam duct. As a result, there is a strong possibility to use aluminium chamber as the storage ring chamber.

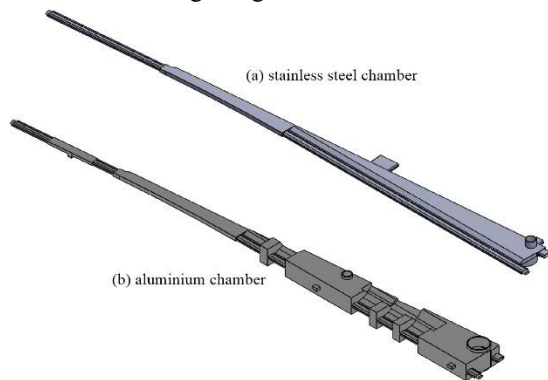

Figure 5: Comparison between stainless steel BC1 chamber(a) and improved aluminium BC1 chamber(b).

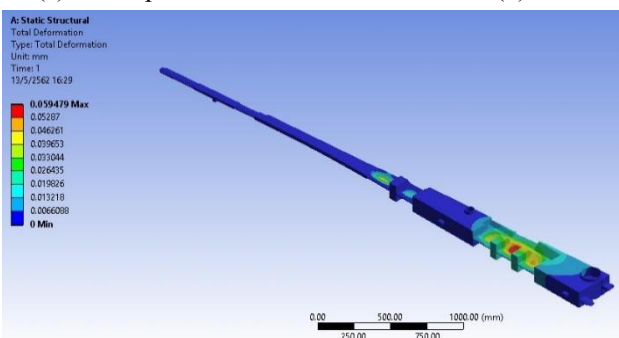

Figure 6: Simulation of the deformation on the chamber BC1 due to the evacuation.

CONCLUSION

The conceptual design of vacuum chamber for SPS-II storage ring is discussed based on stainless steel chamber. The bending chamber is designed as a long triangular chamber to obtain lower impedance, heat load and the residual gas from PSD flowing back to the beam duct. The deformation of aluminium chamber is evaluated. It is possible to use aluminium chamber as the storage ring chamber.

ACKNOWLEDGMENT

The authors wish to thank to Prof. J. R. Chen, G. Y. Hsiung, C. K. Chan, C. C. Chang of National Synchrotron Radiation Research Center (NSRRC), Prof. Z. T. Zhao and X. Hu of Shanghai Advanced Research Institute (SARI), Chinese Academy of Sciences (CAS) for discussion, guidance and suggestion on vacuum system design. The authors also would like to thank Ministry of Higher Education, Science, Research and Innovation (MHESI) for funding support under Thailand-china collaboration project.

REFERENCES

- [1] P. Klysubun, T. Pulampong, and P. Sudmuang, "Design and Optimisation of SPS-II Storage Ring", in *Proc. 8th Int. Particle Accelerator Conf. (IPAC'17)*, Copenhagen, Denmark, May 2017, pp. 2773-2775. doi:10.18429/JACoW-IPAC2017-WEPAB086
- [2] C. K. Chan et al., "Design of the TPS Bending Chamber", in *Proc. 4th Asian Particle Accelerator Conf. (APAC'07)*, Indore, India, Jan.-Feb. 2007, paper THPMA056, pp. 703-705.
- [3] P. Sunwong, P. Klysubun, T. Phimsen, S. Prawanta, and P. Sudmuang, "Magnet Design for Siam Photon Source II", presented at *the 10th Int. Particle Accelerator Conf. (IPAC'19)*, Melbourne, Australia, May 2019, paper FRXXPLM2, this conference.
- [4] S. Prawanta et al., "Design and Construction of Sextupole Magnet Prototype for Siam Photon Source II Project", presented at *the 10th Int. Particle Accelerator Conf. (IPAC'19)*, Melbourne, Australia, May 2019, paper THPTS076, this conference.
- [5] G. Y. Hsiung, Y. J. Hsu, and J. R. Chen, "Photon Stimulated Desorption Phenomena at the Taiwan Light Source Vacuum System", in *Proc. 17th Particle Accelerator Conf. (PAC'97)*, Vancouver, Canada, May 1997, paper 4P023, pp. 3642-3644.
- [6] G. Y. Hsiung et al., "Aluminium ultrahigh vacuum system for the 3 GeV TPS synchrotron light source", in *Journal of Physics Conference Series*, vol. 439, p. 012034, 2013.