

Six-Dimensional Superconformal Field Theories and Their Torus Compactifications

その他のタイトル	6次元超共形場理論とそのトーラスコンパクト化
学位授与年月日	2016-09-16
URL	http://doi.org/10.15083/00075211

学位論文

**Six-Dimensional Superconformal Field Theories
and Their Torus Compactifications**

(6次元超共形場理論とそのトーラスコンパクト化)

2016年6月 博士(理学)申請

東京大学大学院理学系研究科
物理学専攻
大森 寛太郎

Abstract

In this thesis, we study six-dimensional superconformal field theories (SCFTs), brane engineerings of them, and circle/torus compactifications of them.

In the former half, we summarize some of known results about 6d $\mathcal{N}=1$ SCFTs. Since a 6d SCFT sits on UV side of renormalization group flows among 6d theories and is generally strongly coupled, we cannot probe those theories with perturbative methods. However, a tensor branch effective field theory which describes the near IR regime captures some aspects of the strongly coupled UV physics, for example the anomaly polynomial. We will first review the general near IR 6d $\mathcal{N}=1$ physics and the calculation of the anomaly polynomial. Then, we look at brane/singularity engineerings of some specific 6d SCFTs in string/M-theory, which guarantees the existence of 6d SCFTs.

In the latter half, we focus on the circle/torus compactifications of 6d SCFTs. We consider compactifications of two classes of 6d SCFTs. One is very-higgsable theories and the other is theories higgsable to $\mathcal{N}=(2,0)$ theories. As well as finding general properties of such compactifications, we identify 4d theories obtained by the torus compactification for some examples of 6d theories. The 4d theories obtained by the considered compactifications tend to be described by a class S theory or a combination of different class S theories.

Contents

1. Introduction	5
1.1. Motivation	5
1.1.1. General motivation	5
1.1.2. Another reason: compactification	6
1.1.3. What will be actually studied in this thesis	7
1.2. Structure of the thesis and rough summary	8
1.3. General notations and remarks	9
2. Six dimensional superconformal field theories	11
2.1. IR effective spectrum and tensor branch anomaly matching	11
2.1.1. $\mathcal{N} = (1, 0)$ supermultiplets	12
2.1.2. Tensor branch effective theory and Green-Schwartz topological coupling	13
2.1.3. Anomaly matching	16
2.1.4. Non-generic point of tensor branch	21
2.2. Six dimensional $\mathcal{N} = (2, 0)$ theories	22
2.2.1. $\mathcal{N} = (2, 0)$ theories of type A, D from M5-branes	22
2.2.2. $\mathcal{N} = (2, 0)$ theories of type A, D, E from orbifold singularities in Type IIB string	24
2.2.3. Anomaly polynomials for $\mathcal{N} = (2, 0)$ theories	26
2.3. E-string theory	29
2.3.1. Heterotic M-theory description of E-string theory	29
2.3.2. Anomaly polynomials for E-string theories	31
2.4. Conformal matters	32
2.4.1. (A_{k-1}, A_{k-1}) conformal matter	33
2.4.2. (D_k, D_k) conformal matter	35
2.4.3. (E_k, E_k) conformal matter	37
2.4.4. Circle compactification and generalized base-fiber duality	41
2.4.5. Closing the flavors of $\mathcal{T}_N^{(\mathfrak{su}(k), \mathfrak{su}(k))}$	42
2.5. Higgsable to E-string theories	43
2.5.1. M-theory construction	44
2.5.2. Type I' description for $\mathfrak{g} = \mathfrak{su}(k)$	46
3. Circle and torus compactifications	51
3.1. Compactification of very-higgsable theories: $\mathcal{T}_N^{\text{Est}}$ and $\mathcal{T}_0^{(\mathfrak{g}, \mathfrak{g})}$	52
3.1.1. General properties and central charges of ${}^{4\text{d}}\mathcal{T}$	53
3.1.2. ${}^{4\text{d}}\mathcal{T}_0^{(\mathfrak{g}, \mathfrak{g})}$ and Class S	61

3.2.	Compactification of theories higgsable to $\mathcal{T}_N^{\text{Est}}$	64
3.2.1.	IIB web diagrams	65
3.2.2.	4d conformal anomalies	74
3.3.	Compactification of theories higgsable to $\mathcal{T}_G^{(2,0)}$	78
3.3.1.	General structure of theories higgsable to $\mathcal{T}_G^{(2,0)}$	80
3.3.2.	Conformal matters and class S theories: type A	86
3.3.3.	Conformal matters and class S theories, general type	93
4.	Conclusion	99
4.1.	Recapitulation and summary	99
4.2.	Future directions	100
	Acknowledgement	101
	A. Group theory constants and notations	103

1. Introduction

1.1. Motivation

1.1.1. General motivation

Quantum field theory (QFT), the framework that describes our world above the Planck scale, has been a rich research subject in Physics. Among QFTs, the supersymmetric ones are extensively studied and many nontrivial facts are discovered although the real-world QFT, which is the standard model below the electroweak scale, is non-supersymmetric. The reason to study supersymmetric theories is that we would like to understand analytically general features of quantum field theory beyond the level of perturbation, and so far typically we need supersymmetry to investigate such non-perturbative phenomena in QFT. In particular, the fixed points of renormalization group (RG) flow of supersymmetric theories, that is superconformal field theories (SCFTs) are the most important class.

This thesis is devoted in particular to six-dimensional (6d) SCFTs. One of the reasons to study theories in 6d (, not 4d in which we live,) theories is to think of “*What is quantum field theory?*”. In 6d supersymmetric Lagrangian, there is no classically marginal or relevant coupling. Therefore, all the theories are *free* in IR on a generic point of its moduli, and in UV the couplings diverges. In 4d QED, the gauge coupling is classically marginal but IR-free in the quantum theory, meaning that the theory suffers from Landau pole and needs additional scale below the Landau pole that cures the divergence of the gauge coupling. In 6d, every interacting theory looks like having a Landau pole, therefore it seems that there is no way to cure it.

Fascinatingly, this conclusion is not true. String/M-theory constructions [1, 2] established the existence of UV completed 6d supersymmetric $\mathcal{N}=(2, 0)$ ¹ theories, if one believes the consistency of the string/M-theory. Further, there is no need to add scales by hand, but the theory automatically cures itself. In UV, the theory is strongly coupled and there is no known Lagrangian that describes the UV physics. Still, the existence of such theories is as believable as the existence² of string/M-theory because of various consistencies which have been checked.

The very lesson here is that a *QFT is not (necessarily) defined by a Lagrangian*, and 6d SCFTs are good model cases of non-Lagrangian³ theories. We would like to investigate how to treat such theories and calculate physical observables. Actually, the author and the collaborators found

¹The symbol \mathcal{N} denotes the number of supersymmetries by the unit of minimal spinor representation of the considered dimension, as usual. 6d admits symplectic Majorana-Weyl fermions therefore the type of the supersymmetry algebra is specified by a pair of integers each represents the number of supercharges with $+/-$ chiralities. In 6d, $\mathcal{N}=(1, 0)$ supersymmetry algebra has 8 supercharges which is equal to the number of supercharges in 4d $\mathcal{N}=2$ algebra. A brief explanation is in Section 2.1. For more detail, see, for example, Appendixes of [3].

²Here the word “existence” means theoretical (or mathematical) existence. We are not going to discuss whether this world is governed by the string/M-theory.

in [4] that the anomaly polynomial, which is one of physical observables, of a strongly coupled SCFT can be derived only from the data of IR nearly-free physics connected with the considered SCFT by renormalization group flow.

1.1.2. Another reason: compactification

Another reason why we study 6d theories, which is closely related to the above, is that the said dimension is the maximum dimension which admits the superconformal symmetry [5]. A single 6d SCFT can generate various lower dimensional (including 4d) supersymmetric theories via compactification (or dimensional reduction), therefore 6d SCFTs are possibly useful tools to study lower dimensional theories. In fact, the relation between 6d $\mathcal{N}=(2,0)$ theories and 4d $\mathcal{N}=2$ theories called class S theories [6] is known to be much interesting and important.

The final objective of the researches included in this thesis is to generalize this seminal result to less supersymmetric situations. There are much more 6d $\mathcal{N}=(1,0)$ SCFTs than $\mathcal{N}=(2,0)$ ones, therefore we expect richer structure among them and their compactifications.

Class S theories Not only a single QFT has profound aspects but also an appropriate family of QFTs tends to have abundant structures, and such collective features are attracting more and more attentions.

One of the most important family of QFT is the so-called class S theories, introduced by Gaiotto in 2009 [6]. The class S theories are defined by means of the six-dimensional $\mathcal{N}=(2,0)$ theory of type $G = A_n, D_n, E_{6,7,8}$, which we denote $\mathcal{F}_G^{(2,0)}$. A member of the family is a four dimensional $\mathcal{N}=2$ supersymmetric QFT which can be obtained by compactification of the six-dimensional $\mathcal{N}=(2,0)$ theory on a Riemann surface (a smooth two-dimensional surface) C possibly with certain punctures. The existence of 6d $\mathcal{N}=(2,0)$ is conjectured by the string/M-theory, and the theory does not admit any Lagrangian description known so far. However, assuming the existence and a few additional properties deduced easily from string/M-theory miraculously predicts many properties among the class S theories which is otherwise very difficult to see.

The easiest case is when the two-dimensional surface C is a torus T^2 with the flat metric. Then all sixteen supercharges in the 6d $\mathcal{N}=(2,0)$ theory are preserved and therefore the 4d theory is expected to be the $\mathcal{N}=4$ Super Yang-Mills theory (SYM) whose vector field components is described by the Lagrangian

$$\frac{4\pi^2}{g^2} \text{tr} F \wedge \star F + \frac{\theta}{4} \text{tr} F \wedge F. \quad (1.1.1)$$

where F is the field strength of the G vector field.⁴ The complex structure τ (ratio of two period “lengths” of the T^2) is identified with the gauge coupling $\tau = \frac{\theta}{2\pi} + \frac{\pi i}{2g^2}$. This realization of the 4d $\mathcal{N}=4$ SYM is accompanied by a highly nontrivial fact: from 6d point of view, there is a large diffeomorphism acting on T^2 which sends the complex structure τ to $-\frac{1}{\tau}$, the resulting 4d $\mathcal{N}=4$

³Again we would like to remark that non-Lagrangian means there is no *known* Lagrangian now.

⁴In this thesis the field strength F is multiplied by $\frac{1}{2\pi}$ compared to the usual notation used in Physics. With this normalization, F is valued in the integer cohomology when the gauge group is abelian.

SYM should also be invariant under the map. This is called S-duality.^{5 6}

Note that the S-duality is the relation between a strongly coupled theory and a weakly coupled theory, therefore it is very difficult to show the duality starting from the Lagrangian. However, the construction using mysterious $\mathcal{N}=(2,0)$ theory reveals the duality seemingly easily. Yet this is at this stage just that the mystery of the S-duality is translated to the mystery of the 6d $\mathcal{N}=(2,0)$ theory, but the class S construction in [6] also provides other highly nontrivial facts about the $\mathcal{N}=2$ theories. This is why Gaiotto's introduction of class S theories is considered a seminal contribution.

With less supercharges? The aim of the research contained in this thesis is to generalize the above story on 6d $\mathcal{N}=(2,0)$ SCFTs and 4d $\mathcal{N}=2$ theories to theories with less supercharges. In [11, 12], many 6d $\mathcal{N}=(1,0)$ SCFTs (which have eight supercharges) are engineered and classified in the F-theory language. While $\mathcal{N}=(2,0)$ theories are classified by simply-laced Dynkin diagrams which contains two infinite series of A_N, D_N and three exceptions $E_{6,7,8}$, there are much more $\mathcal{N}=(1,0)$ theories.

When an $\mathcal{N}=(1,0)$ theory is compactified on a general Riemann surface, half of the supercharges are broken and thus the resulting 4d theory possesses 4d $\mathcal{N}=1$ supersymmetry. Such construction might enable us to generate various strongly coupled $\mathcal{N}=1$ systems probably we have never known, and to reveal duality relationships among them.

1.1.3. What will be actually studied in this thesis

Torus compactification Although our final goal is to investigate putting $\mathcal{N}=(1,0)$ theories on general Riemann surfaces, in this thesis we will consider only torus (T^2) compactifications of them as a starting point. Since T^2 is flat, all the eight supercharges of a 6d $\mathcal{N}=(1,0)$ theory remains upon the T^2 compactification, giving us a 4d $\mathcal{N}=2$ theories.

Intricate M-theory background A byproduct of the recent researches on the 6d SCFTs was to reveal some intricate facts on M-theory backgrounds [13] which preserves eight supercharges. For example, an M5-brane, which is a six-dimensional object in M-theory, can split into several parts when trapped in the singularity of the ALE space $\mathbb{C}^2/\Gamma_{\mathfrak{g}}$ with $\mathfrak{g} = D_k, E_{6,7,8}$. In this thesis we will see some of such nontrivial physics of M-theory along the way of reviewing the known results on 6d SCFTs.

We would like to emphasize this byproduct, therefore contents in the review part Chapter 2 are described mainly in the M-theory language. It is hoped that the a review part, though it is review, might play a complementary role to the available literature, because in the literature usually 6d SCFTs are engineered and described mainly by means of F-theory.

⁵ This statement is not precise. The global structure of 4d gauge group changes under the S-dual, meaning that the 6d theory is not completely invariant under the large diffeomorphism. See [7].

⁶ The first idea of the S-duality came in [8], and strong evidences for $\mathcal{N}=4$ case were discovered in 90's: e.g. [9]. The relation to 6d theories was proposed in [10] for the abelian case.

1.2. Structure of the thesis and rough summary

Here we explain the structure of the thesis and roughly summarize the result. This thesis contains four chapters: the first one is this introduction, the second one is devoted to reviewing known result (containing slightly new considerations) on 6d SCFTs, the third one includes the main contents about compactifications of 6d SCFTs, and we conclude in the last. The main chapter is further split into three sections. Each section correspond to one of the author's and his collaborators' paper:

- Section 3.1: “6d $\mathcal{N}=(1,0)$ theories on T^2 and class S theories: Part I” [14]
- Section 3.2: “ S^1/T^2 compactifications of 6d $\mathcal{N}=(1,0)$ theories and brane webs” [15]
- Section 3.3: “6d $\mathcal{N}=(1,0)$ theories on T^2 and class S theories: Part II” [16]

Some amount of the results in [14] is also dissolved into Chapter 2.

In Section 3.1, we will consider the torus compactification of a 6d $\mathcal{N}=(1,0)$ SCFT \mathcal{T} which satisfies a condition we call “very-higgsable”. The main result there is

The torus compactification ${}^{4d}\mathcal{T}$ of a very-higgsable 6d theory \mathcal{T} has a strongly coupled 4d $\mathcal{N}=2$ SCFT fixed points. The 4d central charge can be calculated from 6d anomaly polynomial. The torus modulus τ is not a marginal deformation of the 4d SCFT ${}^{4d}\mathcal{T}$, but it is irrelevant.

This is a generalization of well-known relation between the 6d E-string theory and the E_8 theory of Minahan and Nemeschansky. Note that in this case the torus modulus τ is not a marginal deformation of the 4d theory, as opposed to the case of $\mathcal{N}=(2,0)$ theory explained above. This means that the story of class S theory [6] cannot be naively imported into the whole $\mathcal{N}=(1,0)$ theories.

In Section 3.2, we investigate concrete examples of very-higgsable 6d theories, which are higgsable to E-string theory. There we will find

For a theory in the class of very-higgsable theories we consider, the torus compactification is identified with a class S theory whose Gaiotto curve C is a three-punctured sphere.

We will extensively use the method of 5d brane webs [17], generalizing the analysis of [18].

In Section 3.3, we study 6d theories which are “higgsable to $\mathcal{N}=(2,0)$ theories”. An example of a “higgsable to an $\mathcal{N}=(2,0)$ theory” is an $\mathcal{N}=(2,0)$ theory itself. Those theories are not very-higgsable, and thus the above result for very-higgsable theories are not applied. The result can be roughly summarized as follows:

For a 6d theory \mathcal{T} which is higgsable to an $\mathcal{N}=(2,0)$ theory, its torus compactification ${}^{4d}\mathcal{T}$ does not generally have a fixed point composed of a single coupled 4d SCFT (without turning on Wilson lines along the torus). Rather, in some examples the 4d theory ${}^{4d}\mathcal{T}$ has a fixed point containing two class S theories coupled with each other by IR free gauges fields. The torus modulus τ is a marginal deformation of one of them. In some special cases, one of two class S theories happens to be trivial, and the fixed point is a single class S theory.

A $\mathcal{N}=(2,0)$ is included in the “some special cases” mentioned above, and there are infinitely many other $\mathcal{N}=(1,0)$ theories in it. Therefore, we hope many properties of class S theories can be generalized to those cases when we put on those theories on general Riemann surfaces, though it is far from the scope of this thesis.

Possible shortcut This paper is almost linearly organized. However, Section 2.5 and Section 3.2 is somewhat isolated, therefore can be skipped if the contents in Section 3.2 is not needed.

1.3. General notations and remarks

Before starting the main part, we need to define some notations which will be frequently used in the thesis.

First, we are going to discuss various 6d theories. A 6d theory will be denoted by a symbol \mathcal{T} . To denote some specific theories, we will modify the symbol \mathcal{T} like $\mathcal{T}_N^{(\mathfrak{g},\mathfrak{g})}$ (the definition of this theory will be given later). In Chapter 3, we will talk about circle/torus compactifications of a 6d theory \mathcal{T} . The resulting 5d/4d theories are denoted by ${}^{5d}\mathcal{T}$, ${}^{4d}\mathcal{T}$, respectively. If the 6d theory is $\mathcal{T}_N^{(\mathfrak{g},\mathfrak{g})}$, the compactified theories are ${}^{5d}\mathcal{T}_N^{(\mathfrak{g},\mathfrak{g})}$, ${}^{4d}\mathcal{T}_N^{(\mathfrak{g},\mathfrak{g})}$.

In the text various Lie algebras/groups appears. The group theoretical constants and their notations are summarized in Appendix A. We denote 6d gauge groups by \mathfrak{g} rather than G and treat them as Lie algebras. Our consideration will be independent of global structures of 6d gauge groups, so we will not be careful about them, e.g. whether the gauge group is $SU(N)$ or $SU(N)/\mathbb{Z}_N$. The notation G will be used for a type of $\mathcal{N}=(2,0)$ theory, which is classified by $G = A, D, E$ root systems. In Section 3.3

In this thesis we will heavily use the language of differential forms. We use the notation where A means gauge-potential 1-form and F does its field strength 2-form. The star symbol \star denotes the Hodge dual, so that the Yang-Mills action functional is proportional to $\int F \wedge \star F$. We also encounter 2-form field B everywhere in this thesis, and its field strength 3-form is denoted by H . The convention of the Minkowski metric is $(-, +, +, +, +, +)$.

Terminologies defining classes of $\mathcal{N}=(1,0)$ SCFTs To study torus compactifications, it will turn out to be convenient to classify $\mathcal{N}=(1,0)$ SCFTs by the IR fixed point of the Higgs branch flow triggered by a most generic Higgs branch vev. The “very-higgsable” theories refers to theories whose Higgs flow ends at the free fixed point containing only Nambu-Goldstone hypermultiplets. When the generic Higgs flow of a $\mathcal{N}=(1,0)$ SCFT ends at a $\mathcal{N}=(2,0)$ SCFT up to NG hypers, the theories is called “higgsable to $\mathcal{N}=(2,0)$ theory”. As a subclass of very-higgsable theories, theories with Higgs flow go through (higher rank) E-string theory are called “higgsable to E-string theory” in this thesis.

As explained before, very-higgsable theories are considered in Section 3.1, theories higgsable to E-string theory are in Section 3.2, and theories higgsable to $\mathcal{N}=(2,0)$ theory are in Section 3.3. In those sections, the terminologies are used for a bit narrower meaning for technical reasons. The precise definitions of the terminologies are introduced in each corresponding sections.

2. Six dimensional superconformal field theories

In dimensions $d \leq 4$, one might think that it might be best to start from a Lagrangian theory to study (super) conformal field theories. Some CFTs are weakly coupled, and many others can be described as an IR limit of Lagrangian theories in these dimensions. We can exploit many techniques for studying such theories depending on Lagrangian and path-integral formalism. On the other hand, in $d = 5, 6$, a coupling constant in Lagrangian always becomes weak when the theory flow into IR, therefore a non-free fixed point sits at UV. This is a completely different situation from $d \leq 4$.

A known good strategy to find such UV fixed points is string theory construction. Branes in string theory, or an intersection of branes, carry its worldvolume theory on it, and often there is a limit in which the worldvolume theory becomes decoupled from any scales in the string theory. This limit defines a CFT. Another way of obtaining a CFT is from a singularity of a compactification geometry. Actually, a singularity and branes or an intersection of branes are often dual to each other.

While such string theory construction almost ensures the existence of SCFTs (if we believe the existence of string theory), it does not tell us the physics of obtained SCFTs clearly at once. As we will see, in the six-dimensional case, what brane configurations and the singular geometry directly tells us is the low energy effective particles on the tensor branch. Thus, we need to extract informations about UV fixed points from IR effective physics. So far, the only quantities which can be read from general IR effective spectrum is the anomaly polynomial, which is strictly constrained as we will see.

In this chapter, first we remind ourselves nearly free fields with 6d $\mathcal{N} = (1, 0)$ symmetry, and study anomaly constraints on the IR effective theory. Then, we will quickly review string theory construction of 6d SCFTs, mainly focusing on M-theory one.

2.1. IR effective spectrum and tensor branch anomaly matching

As said above, a nontrivial 6d SCFT sits at UV, not IR as in $d \leq 4$, and flows to a free theory in IR. Thus, we have a nearly free Lagrangian theory in near-IR, which consists of 6d $\mathcal{N} = (1, 0)$ super multiplets. There is no relevant deformation preserving this amount of supersymmetry, therefore a possible flow should be triggered by a vev of the scalars [19]. Here we focus on one of two types of scalar vev called the tensor branch, which preserves $\mathfrak{su}(2)_R$ symmetry of the UV theory, and find a strong anomaly constraint on tensor branch theory. Actually, the strong constraint

	components
tensor	$B_{\mu\nu}^+, \xi_i^+, a$
vector	A_μ^+, λ_i^-
hyper	ψ^+, ϕ_i

Table 2.1.: The names and physical components of 6d $\mathcal{N} = (1, 0)$ supermultiplets. The meanings of letters representing component fields can be found in the main text. The fermions ξ^+, λ^- in the tensor and vector multiplets are doublets of $\mathfrak{su}(2)_R$ and the symplectic Majorana-Weyl condition is imposed, while the fermion ψ^+ in the hypermultiplet is neutral under the R-symmetry. As said in the main text, the complex scalars ϕ in the hypermultiplet also form a doublet of $\mathfrak{su}(2)_R$.

also completely determines the anomaly polynomial of the 't Hooft anomalies with respect to gravitational backgrounds, R-symmetry backgrounds, flavor symmetry backgrounds, and their mixtures.

2.1.1. $\mathcal{N} = (1, 0)$ supermultiplets

Let us start from enumerating the 6d $\mathcal{N} = (1, 0)$ supermultiplets whose components have spin no more than 1. A supersymmetry parameter of the 6d $\mathcal{N} = (1, 0)$ supersymmetry transforms as a chirality-plus symplectic-Majorana Weyl spinor ε_i which satisfies

$$\varepsilon_i^* = \varepsilon^{ij} B \varepsilon_j, \quad \Gamma \varepsilon_j = \varepsilon_j \quad (2.1.1)$$

where $i = 1, 2$ is the index of the doublet of the $\mathfrak{su}(2)_R$, ε^{ij} is the antisymmetric tensor, B is a matrix acting on spinors satisfying $B M^{\mu\nu} B^{-1} = -M^{\mu\nu}$ for a Lorentz generator $M^{\mu\nu}$, and Γ is the chirality operator. The supercharge Q_α^i satisfies the commutation relation

$$\{Q_\alpha^i, Q_\beta^j\} = 2\varepsilon^{ij} \Gamma_{\alpha\beta}^\mu \partial_\mu. \quad (2.1.2)$$

In this thesis we will not treat this algebra directly. Instead, all the necessary information are encoded into the bosonic part of the supersymmetric effective action which we will see. There are three types of such multiplets, which are tensor, vector, and hypermultiplets as summarized in Table 2.1.

The only $\mathcal{N} = (1, 0)$ multiplet unique to six dimensions is the tensor multiplet. A tensor multiplet consists of a self-dual tensor field $B_{\mu\nu}^+$, a chirality-plus (Majorana) fermion ξ^+ , and a real scalar a . The self-dual condition means the field strength 3-form H is self-dual: $H = \star H$ with \star being the Hodge star operator under the Minkowski signature.¹ Supersymmetry prohibits a potential for a , and thus each tensor multiplet is accompanied by a real dimension 1 flat direction, which is called the tensor branch. The scalar a is not charged under the $\mathfrak{su}(2)_R$ symmetry, so that the tensor branch vev preserves the R-symmetry. A tensor multiplet reduces to a $u(1)$ vector multiplet in 5d upon circle compactification.

¹The relation between H and B can differ from $H = dB$ since the Bianchi identity for H can be modified. This will be important later for anomaly matching.

A vector multiplet contains a gauge field A_μ valued in a gauge algebra \mathfrak{g} , and a chirality-minus gluino λ^- valued in the adjoint representation. Note that a vector multiplet does not include any scalar field; thus, there is no ‘‘Coulomb branch’’ in 6d.²

A hypermultiplet is composed of a quaternionic scalar ϕ and chirality-plus fermion ψ^+ , whose flat direction is called the Higgs branch, as in the case of lower dimensions. The quaternion scalar ϕ charged as a doublet under the $\mathfrak{su}(2)_R$ symmetry, and thus a Higgs vev breaks the R-symmetry.

A $\mathcal{N} = (2, 0)$ tensor multiplet, which is the only $\mathcal{N} = (2, 0)$ supermultiplet with spin not more than one, can be decomposed into one $\mathcal{N} = (1, 0)$ tensor multiplet and one $u(1)$ vector multiplet.

2.1.2. Tensor branch effective theory and Green-Schwartz topological coupling

We need not only the free supersymmetric spectrum, but also we need possible IR interactions. Here we consider an RG flow from an UV fixed point caused by a generic tensor branch vev, so that the IR theory contains at least one tensor multiplet.

Although there is no local Lagrangian description for the self-dual tensor field B^+ without any auxiliary fields and preserving the manifest 6d Lorentz invariance, in the following we are going to consider ‘‘pseudo-actions’’ for it whose variational derivatives, formally performed ignoring the self-duality, give equations of motion. Path-integral formulations using auxiliary fields or non-local action is available in the literature [20, 21] though the equations of motion are enough in our context.

First, we consider the case with N of tensor multiplets and with none of other types of supermultiplets. The free pseudo-action for the bosonic part of them is

$$-\pi \int \eta^{ij} (da_i \wedge \star da_j + H_i \wedge \star H_j) \quad (2.1.3)$$

with a_i being scalars and H_i being tensors field strengths. As the rule to derive an equation of motion from a pseudo-action, the variation of H_i with respect to B_i is defined as

$$\frac{\delta H_i(x)}{\delta dB(y)_j} = \delta^{(6)}(x - y) \delta_{ij}. \quad (2.1.4)$$

The supersymmetry relates the kinetic terms of scalars and tensors. Note that the kinetic matrix η^{ij} should be positive definite for the scalars to have kinetic terms with the correct sign.

The symmetric matrix η^{ij} is a convention-independent physical quantity when tensor fields are appropriately normalized as follows. The gauge variance of the tensor field is

$$B_i \rightarrow B_i + d\lambda_i \quad (2.1.5)$$

where λ_i is a 1-form gauge parameter. More precisely, λ should be a $U(1)$ connection on the 6-dimensional manifold X_6 . This means when we pick a 2-dimensional submanifold M_2 , the

²Some literature calls the flat direction of a tensor multiplet scalar a the Coulomb branch. In this thesis we avoid that to emphasise that the scalar a belongs to a tensor multiplet, not a vector multiplet.

integral

$$\int_{M_2} d\lambda_i \quad (2.1.6)$$

can take a nontrivial but quantized value when the homology class $[M_2]$ is nontrivial. We normalize so that the minimal value of the above integral is 1, therefore the integral is valued in \mathbb{Z} . The theory possesses surface defects with a coupling to B defined by

$$-2\pi q_{\text{def}}^i \int_{M_2} B_i. \quad (2.1.7)$$

Gauge invariance forces that the defect charge q_{def}^i should be integers. With this defect, The equation of motion and the Bianchi identity become

$$d \star H_i = dH_i = \eta_{ij} q_{\text{def}}^j \text{P.D.}[M_2], \quad (2.1.8)$$

where η_{ij} is the inverse matrix of η^{ij} and $\text{P.D.}[M_2]$ is the Poincaré dual of the homology class $[M_2]$. In the following we raise and lower the indices i, j using η^{ij} and η_{ij} .

The theory should also be able to contain a dynamical string which also couples with B_i . We define the dynamical self-dual string charge q_i using the coupling between a dynamical string q_i occupying M_2 and B_i as

$$2\pi \eta^{ij} q_i \int_{M_2} B_j. \quad (2.1.9)$$

With this coupling, the Bianchi identity becomes

$$dH_i = -q_i \text{P.D.}[M_2]. \quad (2.1.10)$$

We quantize the field strengths H_i so that q_i takes values in \mathbb{Z}^N with N being the number of tensor multiplets, and possible q_i fills the lattice \mathbb{Z}^N .³ Then, the matrix η^{ij} describes the difference between the dynamical charge lattice Λ spanned by q_i and the defect charge lattice Λ^* spanned by $q_{i,\text{def}} = \eta_{ij} q_{\text{def}}^j$. Further, the gauge invariance of the coupling for any integer charge q_i requires

$$\eta^{ij} \in \mathbb{Z} \quad (2.1.11)$$

which is the 6d version of the Dirac-Zwanziger charge quantization [22]. The quotient Λ^*/Λ is an observable of a theory and called the defect group.

Demanding a string/defect preserves a half of the supersymmetry, the supersymmetric comple-

³One can formally add anti-self-dual two-form field making the pseudo-action an actual action, then the quantum consistency requires e^{iS} should be invariant under the gauge transformation. Or, one can discuss without hand-waving pseudo-action argument in the language of differential cohomology [21].

tion of the coupling (2.1.7) and (2.1.9) includes ⁴

$$(\infty - a_i)q_{\text{def}}^i \text{vol}M_2, \quad a_i \eta^{ij} q_j \text{vol}M_2, \quad (2.1.12)$$

where $\text{vol}M_2$ is the volume of M_2 and we dropped an unimportant overall coefficient. As seen, the tension of a dynamical string is controlled by the tensor vev $a^i = \eta^{ij} a_j$. A dynamical string should become massless at the UV SCFT point where $a^i = 0$ since the cosmological constant on the dynamical string is prohibited by the scale invariance of the SCFT. On the other hand, a defect has infinite cosmological constant as it is not dynamical, though its repose to a change of the tensor vev a_i is meaningful. Later, to determine η^{ij} for a theory engineered with branes, we will compare couplings (2.1.12) for minimally charged defects and minimally charged strings.

Here, we would like to make an assumption on the tensor branch theory of 6d SCFT, which we are going to use throughout this thesis. That is:

Given a 6d SCFT, The string charge q_i of a dynamical string completely classifies the type of the string in the tensor branch theory. In other words, no two distinct types of dynamical strings have the same charges.

For every concrete theory treated in this thesis, this assumption holds⁵. The motivation is the following. The tensions of two strings which have the same string charges should be controlled by only one component of the tensor vevs. And changing the difference M of the worldsheet cosmological constants of the two strings seems not to contradict to any low-energy consistency. This is an analogy for the relation between mass parameters and flavor symmetries in 4d $\mathcal{N}=2$ theories. However, since the 6d UV SCFT does not have marginal or relevant deformations, there is no place where such a parameter M arises⁶. Since still there might be an unknown UV mechanism which prohibits the IR parameter M , this argument is not a proof.

Next, we would like to include vector multiplets. The kinetic term for the gauge field $\int F \wedge \star F$ have mass dimension 4, and thus the coupling constant is irrelevant. Instead, a classically marginal coupling $\int a F \wedge \star F$ provides gauge kinetic term via vev of the scalar a . If we assume that the tensor branch effective theory has a UV fixed point, the only available scales in the tensor branch theory are the vev of tensor scalars a_i . Therefore, all gauge couplings should be identified with the vev of tensor scalars. Therefore, the action including bosons in vector and tensor multiplets is

$$2\pi \int \tilde{\eta}^{ia} \left(a_i \frac{1}{4} \text{Tr} F_a \wedge \star F_a + B_i \frac{1}{4} \text{Tr} F_a \wedge F_a \right), \quad (2.1.13)$$

with F_a ($a = 1, \dots, M$) being the field strength for a simple component \mathfrak{g}_a of the whole gauge algebra. We do not assume the tensor branch theory contains abelian vector multiplets, since

⁴Taking M_2 to be the flat plane along the x_1, x_2 direction, the supersymmetric variation of the Lagrangian (2.1.9) is proportional to $\epsilon^{ij} \tilde{e}_i \Gamma^{12} \xi_j$, which can be canceled by the variation of a that is proportional to $\epsilon^{ij} \tilde{e}_i \xi_j$ if the parameter ϵ_i have a definite chirality along the plane.

⁵Further, to the best of the author's knowledge, there is no known counterexample.

⁶The 6d UV theory can be a little string theory. In that case, the UV little string theory is accompanied by a string scale M and therefore the assumption is wrong.

the anomaly cancellation condition which will be discussed later prohibits abelian factor. The coefficients of the two terms are related by supersymmetry again [23].

We call the topological coupling between B and the characteristic class $c_2(F_i) = \frac{1}{4}\text{Tr}F_i \wedge F_i$, which is the second Chern class when the gauge algebra is \mathfrak{su} , the 6d Green-Schwartz coupling, because these terms will play the same role in the 6d anomaly cancellation mechanism [24] as the celebrated 10d Green-Schwartz coupling does in 10d supergravity anomaly cancellation [25], as we will soon see. Therefore, the gauge coupling $1/g^2$ is controlled by the tensor branch vev of a_i .

The Green-Schwartz coupling in (2.1.13) induces a modification of the Bianchi identity for H_i through the equation of motion and the self-dual condition as

$$dH_i = -\eta_{ij}\tilde{\eta}^{ja}c_2(F_a), \quad (2.1.14)$$

where η_{ij} is the inverse matrix of η^{ij} . When a zero-sized (anti-)instanton string in terms of \mathfrak{g}_a localizes on the two-dimensional subspace M , the class $c_2(F_a)$ becomes $-\text{P.D.}[M]$, and the Bianchi identity (2.1.14) get identical to (2.1.10), meaning an instanton string for gauge algebra \mathfrak{g}_a carries charges $q_i^a = -\eta_{ij}\tilde{\eta}^{ja}$ under the tensor fields B_i , forming a sublattice $\Lambda_{\text{instanton}}$ in the charge lattice Λ . The assumption about dynamical string made above requires $\Lambda_{\text{instanton}}$ should be a rank M sublattice of Λ where M is the number of simple components of the gauge algebra.

Further, if a primitive instanton strings have charge V which is not primitive in Λ but x times a primitive vector v , there are two distinguishable types of strings with charge V , one is the instanton, another is coincident x strings with charge v . Therefore, $\Lambda_{\text{instanton}}$ should be a primitive sublattice of Λ . Thus, we can retake a primitive basis of Λ which contains primitive basis of $\Lambda_{\text{instanton}}$, such that

$$\tilde{\eta}^{ia} = \eta^{ia}. \quad (2.1.15)$$

For later use, we rewrite the bosonic action for the tensor and vector multiplets:

$$2\pi \int \eta^{ij} \left(-\frac{1}{2} da_i \wedge \star da_j - \frac{1}{2} H_i \wedge \star H_j + a_i \frac{1}{4} \text{Tr} F_j \wedge \star F_j + B_i c_2(F_j) \right). \quad (2.1.16)$$

Here, formally we regard the gauge algebra as a direct product of N gauge algebras $\oplus_i^N \mathfrak{g}_i$, with \mathfrak{g}_i possibly empty.

2.1.3. Anomaly matching

Classically, any global symmetry in the spectrum and the interactions in a field theory can be gauged by making background fields coupled to the symmetry dynamical. This entail the introduction of the kinetic term for the gauge field when the symmetry is continuous. Quantum anomaly is the obstruction for this gauging procedure in a quantized theory.

One should distinguish anomalies for gauge symmetry and anomalies for global symmetry. The former is a constraint; the gauge anomaly should vanish for the quantum theory to be consistent. The latter is an observable, and can be thought of as an effective action for non-dynamical backgrounds.

The local anomaly of continuous symmetries, which is called 't Hooft anomaly, can be characterized by an anomaly polynomial I_8 defined by the descent equation ⁷

$$I_8 = dI_7^{(0)}, \quad \delta I_7^{(0)} = dI_6^{(1)} \quad (2.1.17)$$

where I_6 is the 6-form which determines the variation of the anomaly effective action W by $\delta W = \int_{X_6} I_6$, and δ is an infinitesimal variation of background fields. The anomaly polynomial I_8 should be an invariant closed 8-form consisting of background fields.

Assume that the considered 6d IR theory has gauge group \mathfrak{g}_i , flavor group \mathfrak{f}_i , and R-symmetry group $R = \mathfrak{su}(2)$. In this thesis we ignore U(1) flavor symmetries, which are anomalous in most cases in 6d, and do not consider U(1) gauge group, therefore we assume $\mathfrak{g}_i, \mathfrak{f}_i$ to be semi-simple. The possible terms in the anomaly polynomial 8-form I_8 can be constructed from the characteristic classes $\text{Tr}_F F_{\mathfrak{f}_i}^4, c_2(F_{\mathfrak{f}_i}) = \frac{1}{4} \text{Tr} F_{\mathfrak{f}_i}^2, c_2(R) = \frac{1}{4} \text{Tr} F_R^2$ and the Pontryagin classes $p_1(T), p_2(T)$ of the tangent bundle TX_6 . For example, I_8 can contain

$$I_8 \supset \text{Tr}_{\mathfrak{f}_i} F_{\mathfrak{f}_i}^4, c_2(F_{\mathfrak{f}_i})c_2(R), c_2(F_{\mathfrak{f}_i})p_1(T), p_2(T). \quad (2.1.18)$$

How about the terms including the gauge field strength $F_{\mathfrak{g}_i}$? As already told, the pure gauge anomaly, namely the terms proportional to $\text{Tr}_{\mathfrak{g}_i} F_{\mathfrak{g}_i}^4$ or $c_2(F_{\mathfrak{g}_i})^2$ should vanish for the theory to be consistent. Further, the UV fixed point should be able to couple with gravity background, which requires that the gauge-gravity anomaly terms, namely $c_2(F_{\mathfrak{g}_i})p_1(T)$, in near IR effective theory should be absent. The mixed R-gauge anomaly $c_2(F_{\mathfrak{g}_i})c_2(R)$ should also vanish, since we require the UV fixed point has superconformal symmetry, which contains R-symmetry. Finally, as we will see in string construction, we are also going to assume all non-U(1) classical flavor symmetry exists after quantization, which requires $c_2(F_{\mathfrak{f}_i})c_2(\mathfrak{g}_i)$ to be absent. In summary, we require that all pure- and mixed- anomalies involving gauge field $F_{\mathfrak{g}_i}$ should vanish, and this is going to give strong constraints on the IR theory spectrum.

Fermions contained in various multiplets induce 't Hooft anomaly I_{naive} from their 1-loop 4-point Feynman diagram. In our notation, which is summarized in Appendix A, the anomaly polynomial of Weyl fermions in a representation ρ becomes

$$\hat{A}(T)\text{tr}_{\rho} e^{iF}, \quad (2.1.19)$$

where $\hat{A}(T)$ is the A-roof genus with respect to the tangent bundle TX_6 of the spacetime. For each $\mathcal{N}=(1,0)$ multiplet, the 1-loop contribution for the anomaly polynomial is also summarized in the Appendix. The important thing is that even for the vector multiplet with non-abelian gauge group, the gauge anomaly is present in 6d, and it is impossible to cancel the gauge anomaly by adding hypermultiplet. Thus, we need another source of anomaly that cancels this. This is completely the same situation as when considering the 10d vector multiplet. Therefore, we expect that the Green-Schwartz coupling induces additional anomaly I_{GS} , and in the total anomaly $I_8 = I_{\text{naive}} + I_{\text{GS}}$ all the anomalies involving gauge field strength might vanish.

As in the 10d Green-Schwartz mechanism, the modified Bianchi identity (2.1.14) requires that

⁷The descent equations should be regarded as equations on the universal line bundle.

the definition of the field strength should change into

$$H_i = dB_i - CS_k, \quad (2.1.20)$$

where CS_k is the Chern-Simons 3-form normalized by $dCS_k = c_2(F_k)$. To this H_i to be invariant, the tensor field B_i should vary under the gauge transformation as it cancels the variation of the Chern-Simons form. The variation of B induces variation of the pseudo-action (2.1.13), though it is not clear that variation calculates correct anomaly. Actually, in [26], using mathematical technique of differential cohomology, it was shown that the contribution to I_8 from the topological coupling is

$$\frac{1}{2} \eta^{ij} c_2(F_i) c_2(F_j). \quad (2.1.21)$$

This 6d version of anomaly contribution was also observed as a required consistency from string theory in [24].

For example, let us see the case where the number N of tensor multiplets is one, the gauge algebra is $\mathfrak{su}(3)$, and there is no hypermultiplet. As stated in Appendix A, the anomaly from fermions in a vector with gauge algebra $\mathfrak{su}(3)$ and a tensor multiplet is

$$I_{\text{naive}} = -\frac{3}{2} c_2(F)^2 - \frac{1}{4} c_2(F) p_1(T) - 3 c_2(R) c_2(F) - \frac{7}{24} c_2(R)^2 - \frac{7}{48} c_2(R) p_1(T) - \frac{11 p_1(T)^2}{1920} - \frac{7 p_2(T)}{480}. \quad (2.1.22)$$

The pure gauge contribution $-\frac{3}{2} c_2(F)^2$ can be canceled by the Green-Schwartz contribution (2.1.21) with $\eta = 3$.

The $\mathfrak{su}(3)$ pure SYM theory with one tensor is the only pure SYM theory allowed by the anomaly cancellation condition with an \mathfrak{su} gauge algebra. For $\mathfrak{su}(N)$, which have an independent quartic Casimir, the naive anomaly polynomial contains a term proportional to $\text{Tr} F^4$, which cannot be killed by the Green-Schwartz contribution composed of $c_2(F)$. For $\mathfrak{su}(2)$, the contribution for the pure gauge anomaly is $-\frac{4}{3} c_2(F)^2$ which is again unable to cancel by (2.1.21) because η should be an integer⁸.

Aside from $\mathfrak{su}(3)$, exceptional gauge algebras $\mathfrak{e}_{6,7,8}, \mathfrak{f}_4$ except for \mathfrak{g}_2 and $\mathfrak{so}(8)$ can form pure SYM theory with one tensor. For those algebras $\text{Tr} F^4$ is related to $c_2(F)^2$, because of non-existence of independent quartic Casimir for exceptional groups and just an accident for $\mathfrak{so}(8)$. Moreover, the coefficient η in I_{GS} is integer for those algebras, as listed in Table 2.2. We will see the UV SCFTs for all of those theories can be engineered in F-theory.

Along this line, one can classify possible gauge algebras and matter hypers with which the gauge anomaly canceled by the Green-Schwartz contribution [27]. The global gauge anomaly coming from the homotopy group $\pi_6(G)$ which exists for $G = \text{SU}(2), \text{SU}(3)$ and G_2 needs also to be considered, and it constrains the number of hypers charged under the gauge group⁹ We do not list up the allowed matter spectra, since we are rather interested in specific theories which can

⁸The global gauge anomaly also prohibits $\mathfrak{su}(2)$ without hypers.

⁹When only fundamental hypers are considered, the number of fundamentals should be $4, 0 \pmod{6}$ for $\text{SU}(2), \text{SU}(3)$, and $1 \pmod{3}$ for G_2 [28].

		$\mathfrak{su}(3)$		$\mathfrak{so}(8)$		\mathfrak{f}_4		\mathfrak{e}_6		\mathfrak{e}_7		\mathfrak{e}_8
η		3		4		5		6		8		12

Table 2.2.: Gauge algebras with which the pure SYM theory with one tensor is allowed by the anomaly can be condition. The number in the second row indicates the coefficient η in I_{GS} which should be an integer.

be engineered from M-theory. It is easy to check that the will-be-appeared tensor branch matter spectra satisfy the gauge anomaly cancellation.

As said, the gauge-gravity and gauge-R mixed anomalies should also vanish to have a UV SCFT. To achieve this, we generalize the Green-Schwartz coupling to include gravity background and R-symmetry background as

$$2\pi \int \eta^{ij} B_i \wedge I_j \quad (2.1.23)$$

with

$$I^i = \eta^{ij} I_j = \tilde{\eta}^{ij} c_2(F_j) + q_{\text{R}}^i c_2(R) + q_{\text{grav}}^j p_1(T). \quad (2.1.24)$$

For a theory which admits an F-theory construction (namely all known 6d $\mathcal{N}=(1,0)$ theories), the coefficient q_{grav}^j is calculated to be [4, 29]¹⁰

$$q_{\text{grav}}^j = \eta^{jj} - 2 \quad (\text{no sum in } j) \quad (2.1.25)$$

Then the Bianchi identity for the field strength H is modified as

$$dH_i = -I_i, \quad (2.1.26)$$

and the contribution to the anomaly I_{GS} from this modified tensor field strength is

$$I_{\text{GS}} = \frac{1}{2} \eta^{ij} I_i I_j. \quad (2.1.27)$$

Therefore, the whole anomaly polynomial I_{tot} is the sum of the naive one-loop contribution I_{naive} and the above Green-Schwartz contribution I_{GS} :

$$I_{\text{tot}} = I_{\text{naive}} + I_{\text{GS}} \quad (2.1.28)$$

For the case of pure $\mathfrak{su}(3)$ with one tensor (2.1.22), the cancellation of gauge anomalies requires

$$I = c_2(F) + c_2(R) + \frac{1}{12} p_1(T). \quad (2.1.29)$$

The total anomaly polynomial, which is equivalent to the anomaly polynomial of the UV SCFT

¹⁰ There are some theories dropped from the classification of [11, 12]. Such theories still can be constructed in F-theory when $O7^+$ orientifold is taken into account [30]. For such theories the calculation [4, 29] is not true because $-\eta^{ij}$ differs from the geometrically defined intersection form, but the result $q_{\text{grav}}^j = \eta^{jj} - 2$ still holds.

by 't Hooft anomaly matching, is

$$\begin{aligned} I_{\text{tot}} &= I_{\text{naive}} + I_{\text{GS}} \\ &= \frac{5}{48} c_2(R) p_1(T) + \frac{29}{24} c_2(R)^2 + \frac{3}{640} p_1(T)^2 - \frac{7p_2(T)}{480}. \end{aligned} \quad (2.1.30)$$

In general, when the number M of the simple components of the gauge algebra is maximal, i.e. is equal to the number N of tensor multiplet, the contribution I_{GS} is completely determined by the gauge anomaly cancellation condition, and the total anomaly polynomial can be obtained by square-completing I_{naive} and then subtracting the constant part. We are going to see other examples in the following. For the case of $M < N$, which include the most important $\mathcal{N} = (2, 0)$ case where $M = 0$, we need other information on 6d SCFT obtained e.g. from string realization to determine the total anomaly polynomial.

2.1.3.1. Notation

Here we would like to introduce a notation which appeared in [11, 13]. It often happens that the tensor branch theory is “linearly shaped”, namely

$$\eta^{ij} = \begin{cases} 1 & |i - j| = 1 \\ 0 & |i - j| > 1 \end{cases}. \quad (2.1.31)$$

In that case, we denote the tensor branch effective theory as

$$\begin{array}{ccccccc} & & [f_2] & \cdots & [f_{N-1}] & & \\ [f_1] & \mathfrak{g}_1 & \mathfrak{g}_2 & \cdots & \mathfrak{g}_{N-1} & \mathfrak{g}_N & [f_N] \\ & \eta^{11} & \eta^{22} & \cdots & \eta^{N-1, N-1} & \eta^{NN} & \end{array}. \quad (2.1.32)$$

The numbers under the i th gauge algebra denotes the diagonal component η^{ii} of the charge matrix, and the algebras f_i in square brackets mean flavor symmetries, which will often be abbreviated. \mathfrak{g}_i can be $\emptyset, \mathfrak{usp}(0)$ or $\mathfrak{su}(1)$. \emptyset and $\mathfrak{usp}(0)$ both means there is nothing other than a tensor multiplet, while $\mathfrak{su}(1)$ always neighbors a node with $\mathfrak{su}(2)$ and there is a “ $\mathfrak{su}(1) - \mathfrak{su}(2)$ bifundamental” which is actually a fundamental of $\mathfrak{su}(2)$ ¹¹. The off-diagonal component η^{ij} is considered 1 when i, j are adjacent and is zero otherwise. Typically, on a generic point of the tensor branch, there are bifundamental hypers between adjacent gauge or flavor algebras, otherwise it should be mentioned.

Further, generalizing the notation, if some of η^{ij} is not 1, we write as follows:

$$\begin{array}{ccccccc} [\mathfrak{g}_L] & \mathfrak{g}_1 & & \mathfrak{g}_2 & \cdots & \mathfrak{g}_N & [\mathfrak{g}_R] \\ & \eta^{11} & \langle \eta^{12} \rangle & \eta^{22} & \cdots & \eta^{NN} & \end{array}. \quad (2.1.33)$$

where abbreviated η^{ij} are still considered to be 1.

¹¹ $\mathfrak{usp}(0)$ is used as a special case of $\mathfrak{usp}(2N)$ with $N = 0$, and the meaning is the same as \emptyset . The notion $\mathfrak{su}(1)$ means the Kodaira type I_1 fiber in the F-theory literature. See [31] for more detail.

2.1.4. Non-generic point of tensor branch

At the origin of the tensor branch where $a^i = 0$ for all i , the UV SCFT \mathcal{T}_{UV} arises. Here we consider the subspace of the tensor branch where $a^k = 0$ for a certain k while $a^i \neq 0$ for $i \neq k$. We use the index \hat{i}, \hat{j} which runs the same region as i, j but $\hat{i}, \hat{j} \neq k$. On the subspace, a string with string charge $q_i = \delta_i^k$ becomes massless while other strings remain massive. Then the IR theory contains both a strongly coupled SCFT sector which we denote \mathcal{T}_k and a weakly coupled Lagrangian sector.

Since the tensor multiplet including a^k is contained in the strongly coupled SCFT sector \mathcal{T}_k , there are only $N - 1$ weakly coupled tensor mode out of N tensor modes at a generic point. The original kinetic term for tensor scalars is

$$\eta_{ij} da^i \wedge \star da^j = \hat{\eta}_{\hat{i}\hat{j}} da^{\hat{i}} \wedge \star da^{\hat{j}} + \text{terms including } a^k, \quad (2.1.34)$$

which implies the kinetic matrix $\hat{\eta}_{\hat{i}\hat{j}}$ for the remaining scalars $a^{\hat{i}}$ is obtained by just omitting k th row and column: $\hat{\eta}_{\hat{i}\hat{j}} = \eta_{ij}$. We define charge matrix $\hat{\eta}^{\hat{i}\hat{j}}$ by the inverse matrix of $\hat{\eta}_{\hat{i}\hat{j}}$. The new charge matrix $\hat{\eta}^{\hat{i}\hat{j}}$ with upper indices is

$$\hat{\eta}^{\hat{i}\hat{j}} = \eta^{ij} - \frac{\eta^{ik} \eta^{jk}}{\eta^{kk}}. \quad (2.1.35)$$

Note that when $\eta^{kk} \geq 2$, $\hat{\eta}^{ij}$ becomes fractional, meaning the gauge parameters $\hat{\lambda}_i$ for tensor fields $\hat{B}_j = \hat{\eta}_{j\hat{j}} B^{\hat{j}}$ satisfies $\int_{M_2} \hat{\lambda}_i \in \eta^{kk} \mathbb{Z}$ for $\eta^{kk} \neq 0$. Instead of re-normalizing \hat{B} , we rather keep this normalization.

Let us rephrase what was said using the notation introduced in the previous section for the case where (2.1.31) is satisfied. When a^k set to be zero, the tensor branch structure (2.1.32) reduces to

$$[\mathfrak{g}_L] \quad \mathfrak{g}_1 \quad \mathfrak{g}_2 \quad \cdots \quad \mathfrak{g}_{k-1} \quad \langle \hat{\eta}^{k-1, k+1} \rangle \quad \mathfrak{g}_{k+1} \quad \cdots \quad \mathfrak{g}_N \quad [\mathfrak{g}_R], \quad (2.1.36)$$

and the \mathfrak{g}_{k-1} and \mathfrak{g}_{k+1} vectors are coupled with the SCFT \mathcal{T}_k which should have $\mathfrak{g}_{k-1} \oplus \mathfrak{g}_{k+1}$ flavor. The most frequently seen case is when $\eta^{kk} = 1$ ¹². In this case the tensor branch structure reduces like

$$\begin{array}{cccc} \mathfrak{g}_{k-1} & \mathfrak{g}_k & \mathfrak{g}_{k+1} & \\ \eta^{k-1, k-1} & 1 & \eta^{k+1, k+1} & \end{array} \implies \begin{array}{cc} \mathfrak{g}_{k-1} & \mathfrak{g}_{k+1} \\ \eta^{k-1, k-1} - 1 & \eta^{k+1, k+1} - 1 \end{array}. \quad (2.1.37)$$

We name the subspace of the tensor branch where we can reach through the recursive uses of the operation (2.1.37) a contracted subspace. Further, we let the most singular subbranch in the contracted subspace called the endpoint (although it is not a point) according to [11]. On the endpoint no diagonal component of the kinetic matrix $\hat{\eta}^{\hat{i}\hat{j}}$ for not-shrunk tensors is 1.

After shrinking a^k , the remaining GS coupling is merely $\int B^i I_i$, and the contribution to the anomaly polynomial from this remaining GS coupling is $\hat{I}_{GS} = \frac{1}{2} \hat{\eta}^{\hat{i}\hat{j}} I_i I_j$. Using the tensor branch

¹²This is because in the F-theory language shrinking the cycle with self-intersection number $-\eta^{kk} = -1$ does not make singularity of the base geometry worse. Therefore, such contractions is convenient to classify possible singularity structure [11].

structure (2.1.36) after shrinking a^k , the total anomaly polynomial $I[\mathcal{T}_{UV}]$ is calculated as

$$I[\mathcal{T}_{UV}] = \hat{I}_{\text{naive}} + I[\mathcal{T}_k] + \hat{I}_{\text{GS}} \quad (2.1.38)$$

where \hat{I}_{naive} is the contribution from Lagrangian matters in (2.1.36). Compared with the original formula

$$I[\mathcal{T}_{UV}] = I_{\text{naive}} + I_{\text{GS}}, \quad (2.1.39)$$

from the tensor branch structure at a generic point, we have

$$\begin{aligned} I[\mathcal{T}_k] &= I_{\text{naive},k} + I_{\text{GS}} - \hat{I}_{\text{GS}} \\ &= I_{\text{naive},k} + \frac{1}{2} \frac{1}{\eta^{kk}} I^k I^k. \end{aligned} \quad (2.1.40)$$

with $I_{\text{naive},k}$ being the one-loop contribution from tensor including a^k , vector coupled with a^k , and hypers coupled with the vector. This means in the $a^i \rightarrow \infty$ keeping a^k finite, the remaining pseudo-action including B^k is

$$-\pi \int \frac{1}{\eta^{kk}} (H^k \wedge *H^k + 2B^k I^k). \quad (2.1.41)$$

2.2. Six dimensional $\mathcal{N} = (2, 0)$ theories

In the previous section we used a “bottom-up” approach, meaning that we searched consistency conditions for a Lagrangian IR theory to be UV-completed by an SCFT. From now on, we are going to use “top-down” approach, namely engineering 6d SCFT itself with branes/singularities in string/M/F-theory. In this section, we focus on 6d SCFTs with maximal supersymmetry $\mathcal{N}=(2, 0)$.

$\mathcal{N}=(2, 0)$ SCFTs are believed to be classified by $A_n, D_n, E_{6,7,8}$ root system. We denote the $\mathcal{N}=(2, 0)$ theory of type G by $\mathcal{T}_G^{(2,0)}$ where G specifies one of A, D, E root system. The IR effective theory should be $\mathcal{N}=(2, 0)$ tensor multiplets, and the kinetic matrix η^{ij} is thought to be the Cartan matrix of corresponding A, D, E . Actually the reference [32] argues that the matrix η^{ij} of a tensor branch kinematic matrix η^{ij} of an $\mathcal{N}=(2, 0)$ theory should be the Cartan matrix of one of A, D, E root systems, from anomaly cancellation with respect to the worldsheet theory of the massive strings in the tensor branch theory.

In the following we will remind M/string constructions of $\mathcal{N}=(2, 0)$ theories and important consequences from the constructions. The $\mathcal{N}=(2, 0)$ theory of type A_n or D_n can be constructed by branes in eleven-dimensional M-theory [2]. The $\mathcal{N}=(2, 0)$ theory of type $E_{6,7,8}$ cannot be engineered by branes in M-theory, but an orbifold singularity in Type IIB string allows us to construct them [1].

2.2.1. $\mathcal{N} = (2, 0)$ theories of type A, D from M5-branes

The M-theory is the (thought-to-exist) UV completion of the 11d supergravity. The 11d supergravity contains a three form field $C_{\mu\nu\rho}$, which is accompanied by two types of M-theory branes

each coupled to the 3-form field C or the dual 6-form field C^\vee with $dC^\vee = \star dC$. The former brane with three dimensions is called M2-brane and the latter brane with six dimension is called M5-brane.

We can decouple the $\mathcal{N}=(2,0)$ supersymmetric 6d worldvolume theory on M5 branes from the 11d supergravity sector of by taking the limit where the 11d Planck length ℓ_P goes to zero. The worldvolume theory on a single M5-brane is thought to be a free $\mathcal{N}=(2,0)$ tensor multiplet. When there are two parallel M5-branes at a distance of \tilde{a} , there can be an open M2-brane bridging two M5-branes which looks a massive string with tension \tilde{a}/ℓ_P^3 . Thus, if we take the $\ell_P \rightarrow 0$ limit with $a^1 = \tilde{a}/\ell_P^3$ fixed, the decoupled theory has massive strings with tension a^1 in its spectrum.

The scaled distance a^1 , which have the mass dimension of a 6d scalar, is nothing but the tensor branch vev of the decoupled theory. Note that this a^1 should be identified with a tensor scalar with upper index in our notation since the massive string tension is determined by a^i :(2.1.12). At the origin $a^1 = 0$ of the tensor branch, the string becomes massless. Correspondingly, the theory on coincident two M5-branes should be a non-free theory. Further, since there is no available scale after taking the $\ell_P \rightarrow 0$ limit when the two M5 collides, the worldvolume theory is expected to be an SCFT. Actually there is the rotational isometry $SO(5)$ emerges around M5-branes in the M-theory geometry, which is identified with $SO(5)_R$ symmetry of $\mathcal{N}=(2,0)$ supersymmetry, indicating restoration of the $\mathcal{N}=(2,0)$ superconformal symmetry. The SCFT on coincident two M5-branes is called $\mathcal{N}=(2,0)$ theory of type A_1 after ignoring the center-of-mass mode of the two M5s.¹³ This construction generalizes to the case of $\mathcal{T}_{A_N}^{(2,0)}$, namely the worldvolume theory on the coincident $N+1$ M5-branes up to the center-of-mass mode.

Let us determine the charge matrix η^{ij} . For simplicity, we consider the $\mathcal{T}_{A_1}^{(2,0)}$ case. The tensor branch theory is a $\mathcal{N}=(2,0)$ tensor multiplet whose scalar corresponds to the distance between two M5-branes scaled by ℓ_P^3 . As said, the massive dynamical string comes from an M2-brane suspended between the M5-branes, and a defect comes from a half-infinite M2-brane ending one of the M5-branes as depicted in Figure 2.1. From this picture, one can read off the coupling (2.1.12). When the vev a^1 increases by Δa^1 fixing the center of mass, the length of M2 bridging M5s increases by the same amount, while the length of a half-infinite M2 decreases only by $\frac{1}{2}\Delta a^1$. Therefore, the dynamical string charge is twice of negative of the defect charge, meaning $\eta = 2$. For $\mathcal{T}_{A_N}^{(2,0)}$, the same consideration reveals

$$\eta^{ij} = \begin{cases} 2 & i = j \\ -1 & |i - j| = 1, \\ 0 & \text{otherwise} \end{cases} \quad (2.2.1)$$

which is the Cartan matrix of A_N type. The non-diagonal component comes from the fact that the dynamical string coupled with a^{i+1} behaves as a defect charged under a^i when a^{i+1} goes infinite.

The important property of the theory $\mathcal{T}_{A_n}^{(2,0)}$ is that its compactification on S^1 is the 5d maximally super Yang-Mills(MSYM) with gauge group $G = A_N$. This fact comes from that an M5 brane

¹³Ignoring the center-of-mass mode makes the theory “meta”, meaning the theory gain discrete gravitational anomaly. For such a theory, background geometry is not enough to define its partition function, which is similar to 2d non-modular-invariant chiral CFTs [7].

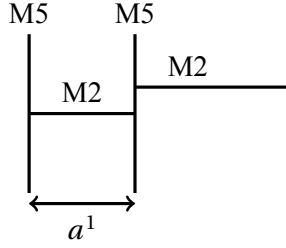

Figure 2.1.: The brane engineering of $\mathcal{F}_{A_1}^{(2,0)}$. The tensor vev corresponds to the distance between M5s and a string and a defect are created by M2.

wrapping the M-circle is identified with a D4-brane in the Type IIA string, and the worldvolume theory of coincident $N+1$ D4-branes is the 5d MSYM. The relation between the 5d gauge coupling g and the M-circle radius R_6 is

$$\frac{1}{R_6} = \frac{8\pi^2}{g^2}. \quad (2.2.2)$$

which identifies the KK-scale and the one-instanton action, since a D0-brane in Type IIA comes from a momentum along the M-circle.

The tensor branch of the 6d theory goes to the Coulomb branch of 5d MSYM, and a self-dual string on the tensor branch wrapping M-circle becomes a W-boson. Thus, the self-dual string charge matrix η^{ij} should be identified with the charge matrix of W-bosons under the $U(1)$ gauge symmetries remaining on the tensor branch, and thus η^{ij} should be the Cartan matrix of $G = A_N$, which is consistent with what we observed.

It is also possible to construct $\mathcal{F}_{D_N}^{(2,0)}$. M-theory admits a \mathbb{Z}_2 ‘‘orientifold’’ action which flips the 5 coordinates $x^{6\sim 10}$. It also flips the sign of the three form field $C = C_{\mu\nu\rho} dx^\mu dx^\nu dx^\rho$. The fixed plane of this action is called MO5-plane, and becomes $O4^-$ when compactified [33]. Therefore, N M5-branes stacked with MO5 the charge matrix η^{ij} equals the Cartan matrix of $G = D_N$, because when the branes and the plane wrapping the M-circle are identified with D4-branes and an $O4^-$ which produces 5d D_N MSYM. The relation (2.2.2) also holds for this $G = D_N$ case.

2.2.2. $\mathcal{N} = (2, 0)$ theories of type A, D, E from orbifold singularities in Type IIB string

One might wonder whether an $\mathcal{N}=(2,0)$ theory $\mathcal{F}_G^{(2,0)}$ for another root system G exists. The answer is that G should be simply-laced, and thus other possibilities are $G = E_{6,7,8}$. However, no method to engineer $G = E_{6,7,8}$ case in M-theory frame is known (so far). Therefore, we should go to another frame by string duality chain to generalize the above M-theory construction.

To do that, let us first play with $G = A_N$ case. We start from $N+1$ M5 branes occupying the directions $x^{0\sim 5}$. Compactifying x^{10} gives Type IIA string theory with $N+1$ NS5 branes occupying $x^{0\sim 5}$. We would like to further compactify x^9 and take T-dual with respect to that direction. It is known that an NS5-brane transforms into a KK monopole in the T-dualized frame, therefore after doing the described duality chain we obtain the Type IIB string on the multi-centered Taub-NUT space.

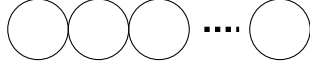

Figure 2.2.: The exceptional divisor of the singularity $\mathbb{C}^2/\mathbb{Z}_{N+1}$. It contains N irreducible components each isomorphic to $\mathbb{C}\mathbb{P}^1$, and they are linearly aligned so that an irreducible component intersects with neighbor components.

Colliding the centers of the Taub-NUT space gives a singular space, and the singularity structure is the same as the singularity of A_N -type ALE orbifold $\mathbb{C}^2/\mathbb{Z}_{N+1}$. Thus, we conclude the duality

$$N + 1 \text{ coincident M5-branes in M-theory} \stackrel{\text{duality}}{\Leftrightarrow} \text{Type IIB on } \mathbb{C}^2/\mathbb{Z}_{N+1} \quad (2.2.3)$$

after taking CFT-decoupling limits in both sides.

How are the tensor branch parameters realized in the Type IIB frame? The singularity of $\mathbb{C}^2/\mathbb{Z}_{N+1}$ admits blow-up resulting in a smooth space with the exceptional divisor consisting of N irreducible components C_i each isomorphic to $\mathbb{C}\mathbb{P}^1$ depicted in Figure 2.2. In the above duality (2.2.3), the distance between M5 branes, or the tensor branch vev a_i , is mapped to the sizes of irreducible components of the exceptional divisor. The kinetic matrix η^{ij} of the scalars a_i is related to that of scalars $b_i = i \int_{C_i} B_{10d}$ by supersymmetry with B_{10d} being the NSNS two-form field, which can be read from

$$\int_{X_6 \times \mathbb{C}^2/\mathbb{Z}_{N+1}} dB_{10d} \wedge \star dB_{10d} = \int_{X_6} \sum_{i,j} (-C_i \cdot C_j db_i \wedge \star db_j) \quad (2.2.4)$$

where $C_i \cdot C_j = \int_{C_i} \text{P.D.}[C_j]$ is the intersection form of the 2-cycles. Thus, for the duality to be consistent, $C_i \cdot C_j$ should be the minus of the Cartan matrix of A_N root system.

A massive string on the tensor branch is realized by a D3-brane wrapping the exceptional divisor in the Type IIB frame. A D3-brane filling 4-manifold M_4 has a charge for the anti-self-dual 5-form field strength F_5 so that the Bianchi identity becomes

$$dF_5 = -\text{P.D.}[M_4]. \quad (2.2.5)$$

Compactifying Type IIB string on the resolved $\mathbb{C}^2/\mathbb{Z}_N$, the localized modes of F_5 can be described by the self-dual 3-form field strengths H_i related to F_5 by

$$dF_5 = \sum_i H_i \wedge \text{P.D.}[C_i], \quad (2.2.6)$$

which mean a D3-brane wrapping C_i and filling two-dimensional subspace M transverse to the resolved $\mathbb{C}^2/\mathbb{Z}_N$ has H_i charge as

$$dH_i = \text{P.D.}[M], \quad (2.2.7)$$

as expected.

This Type IIB orbifold construction of $\mathcal{N}=(2,0)$ theories can be generalized to more general ALE orbifold \mathbb{C}^2/Γ_G where Γ_G is a finite subgroup of $SU(2)$ acting on \mathbb{C}^2 labeled by a simply-laced

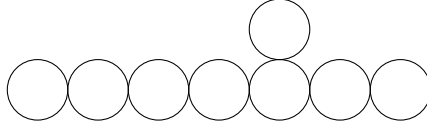

Figure 2.3.: The exceptional divisor of the singularity $\mathbb{C}^2/\Gamma_{E_8}$. The irreducible components are aligned along the E_8 Dynkin diagram. This pattern holds also for other ALE singularities.

root system via the McKay correspondence. Concretely, Γ_{A_N} is \mathbb{Z}_{N+1} , Γ_{D_N} is the binary dihedral group of order $4N-8$, and $\Gamma_{E_{6,7,8}}$ is binary tetrahedral, octahedral, icosahedral group, respectively. The intersection form of 2-cycles in resolved \mathbb{C}^2/Γ_G is known to be equal to minus of the Cartan matrix of the root system of type G , so is the charge matrix of corresponding $\mathcal{N}=(2,0)$ theory. For example, the exceptional divisor of $\mathbb{C}^2/\Gamma_{E_8}$ can be depicted as Figure 2.3.

For $G = D_N$, we have both M-theory brane construction and Type IIB orbifold construction and we expect those are dual:

$$N \text{ M5-branes stacked with OM5-plane in M-theory} \overset{\text{duality}}{\Leftrightarrow} \text{Type IIB on } \mathbb{C}^2/\Gamma_{D_N} \quad (2.2.8)$$

and actually the orientifold process in M-theory producing OM5 is mapped to orbifolding with respect to a \mathbb{Z}_2 isometry of the multi-centered Taub-NUT space resulting in a singularity isomorphic to the singularity of $\mathbb{C}^2/\Gamma_{D_N}$.

For $G = E_{6,7,8}$, we cannot go to the M-theory frame which was convenient to read off the S^1 compactified theory. However, we still expect that the compactified theory is the 5d MSYM with gauge group G , since D3-branes wrapping $C_i \times S^1$ have the same charge matrix as the W-bosons of gauge group G .

2.2.3. Anomaly polynomials for $\mathcal{N}=(2,0)$ theories

The anomaly polynomial for A -type $\mathcal{N}=(2,0)$ is first derived in [34,35] by calculating the anomaly-inflow into $N+1$ M5-branes filling X_6 of M-theory spacetime $X_{11} = X_6 \times \mathbb{R}^5$. In brief, the Chern-Simons coupling of the M-theory,

$$2\pi \int_{X_{11}} \left(\frac{1}{6} C \wedge G \wedge G - C \wedge I_8 \right), \quad I_8 = \frac{1}{48} \left(p_2(TX_{11}) - \frac{1}{4} (p_1(TX_{11}))^2 \right), \quad (2.2.9)$$

together with the coupling between $N+1$ M5-branes and the C field

$$2\pi N \int_{X_6} C^\vee \quad (2.2.10)$$

induces anomalous variation in terms of $SO(5)$ rotation symmetry of the transverse \mathbb{R}^5 , which should be the anomaly of the worldvolume theory of $N+1$ M5-branes. The resulting anomaly

8-form of $\mathcal{F}_{A_N}^{(2,0)}$ with the center-of-mass $\mathcal{N}=(2,0)$ tensor multiplet is

$$\begin{aligned} I[N+1 \text{ M5-branes}] &= I[\mathcal{F}_{A_N}^{(2,0)}] + I[\mathcal{N}=(2,0) \text{ tensor}] \\ &= \frac{(N+1)^3}{24} p_2(\text{SO}(5)_R) - (N+1)I_8 \end{aligned} \quad (2.2.11)$$

with identifying $p_i(TX_{11}) = p_i(TX_6) + p_i(\text{SO}(5)_R)$ where $p_i(\text{SO}(5)_R)$ is the Pontryagin class of the $\text{SO}(5)_R$ bundle coming from the transverse \mathbb{R}^5 . Note that the characteristic N^3 behavior cannot be reproduced by a gauge theory and therefore such contribution should come from intricate physics of massless strings.

The reference [36] conjectured the following formula for general $\mathcal{F}_G^{(2,0)}$:

$$I[\mathcal{F}_G^{(2,0)}] = \frac{h_G^\vee d_G}{24} p_2(\text{SO}(5)_R) + r_G I[\mathcal{N}=(2,0) \text{ tensor}]. \quad (2.2.12)$$

For $G = D_N$ this conjecture is confirmed by anomaly-inflow calculation in [37]. In the following we would like to derive this in an almost field-theoretical way, where the only information from string/M-theory is that the S^1 compactification is the 5d MSYM [4].

As we studied in the Subsection 2.1.3, the anomaly polynomial should decompose as

$$I[\mathcal{F}_G^{(2,0)}] = r_G I[\mathcal{N}=(2,0) \text{ tensors}] + I_{\text{GS}} \quad (2.2.13)$$

where the Green-Schwartz contribution is

$$I_{\text{GS}} = \frac{1}{2} \eta^{ij} I_i I_j. \quad (2.2.14)$$

Therefore, what we should know is the Green-Schwartz coupling I_i . Since the IR theory of an $\mathcal{N}=(2,0)$ theory does not contain any vector multiplet, we cannot determine I_i by gauge anomaly cancellation condition. Instead, we use the S^1 compactification as mentioned.

Upon S^1 compactification with radius R_6 , $\mathcal{F}_G^{(2,0)}$ becomes the 5d MSYM with gauge group G , and on its Coulomb branch, which comes from the 6d tensor branch, we have $U(1)^{r_G}$ vector multiplets and massive states with masses proportional to the Coulomb branch vev. The Coulomb branch vectors A_i^{5d} come from the 6d tensors with relation $A_{i,\mu}^{5d} = \frac{1}{R_6} B_{i,\mu 5}$. The Green-Schwartz coupling (2.1.23) turns into the 5d Chern-Simons coupling

$$2\pi \int \eta^{ij} A_i^{5d} \wedge I_j, \quad (2.2.15)$$

with unknown 4-forms I_j . The vev break the $\text{SO}(5)_R$ symmetry down to $\text{SU}(2)_R \times \text{SU}(2)_L$, and thus I_j depends on $\text{SU}(2)_R$ and $\text{SU}(2)_L$ backgrounds.

Since we have a Lagrangian UV description of the 5d theory which is MSYM as opposed to the 6d theory itself, the above CS coupling in the Coulomb branch IR theory is calculable from the UV MSYM. Actually, integrating out massive fermions creates CS terms through the triangle Feynman diagram [38]. A fermion with mass term coefficient m (with its sign meaningful), $U(1)$

charge q , and having the representation ρ under a background non-abelian field strength F_{BG} , which is now the $\text{su}(2)$ R-symmetry background, produces the CS term

$$2\pi \int \frac{1}{2}(\text{sign}m)qA^{5\text{d}} \wedge \left(\frac{1}{2}\text{tr}_\rho F_{\text{BG}}^2 + d_\rho \frac{1}{24}p_1(T) \right). \quad (2.2.16)$$

The characteristic class $\frac{1}{2}\text{tr}_\rho F_{\text{BG}}^2 + d_\rho \frac{1}{24}p_1(T)$ counts the number of zero modes of ϕ in the presence of the background instantons, and $\frac{1}{2}(\text{sign}m)q$ is the shift of $\text{U}(1)$ charge of the to instantons. (2.2.16) can also be recognized as the CS coupling in the instanton worldline action.

All the remaining things to do is enumerate massive fermions and their charges in the Coulomb branch theory. For each root α of the 5d gauge group G , there is a massive $\mathcal{N}=2$ vector multiplet with mass $|\nu \cdot \alpha|$ and charges under the unbroken $\text{U}(1)^{r_G}$ determined by α . To see the sign of the mass term of massive fermions in the multiplet, note that the Yukawa coupling of the $\mathcal{N}=2$ multiplet is

$$\psi \Gamma^I \phi^I \cdot \alpha \psi \quad (2.2.17)$$

where Γ^I is the Gamma matrices of $\text{SO}(5)_R$ symmetry with I being the index of it, and ψ is charged under the R-symmetry as a spinor. We give vev to only one of ϕ^I , say $\phi^{I=5} = \nu$, breaking $\text{SO}(5)_R$ into $\text{SO}(4) \simeq \text{SU}(2)_R \times \text{SU}(2)_L$. Then the components of ψ with $\text{SO}(5)_R$ -chirality-minus has mass coefficient $-\nu \cdot \alpha$ and forms a $\text{SU}(2)_R$ doublet, while those with $\text{SO}(5)_R$ -chirality-plus has mass coefficient $+\nu \cdot \alpha$ and forms a $\text{SU}(2)_L$ doublet. Under this identification of $\mathcal{N}=1$ subgroup of $\mathcal{N}=2$ supersymmetry algebra, the $\text{SO}(5)_R$ -chirality-minus fermions are considered to belong to $\mathcal{N}=1$ massive hypermultiplets since they are charged under $\text{SU}(2)_R$, while other fermions belong to massive vector multiplets.

Substituting these informations into (2.2.16), the CS coupling is

$$2\pi \int \eta^{ij} A_i^{5\text{d}} \wedge \sum_{\alpha:\text{root}} \frac{1}{4} \alpha_j \text{sign}(\nu \cdot \alpha) (c_2(L) - c_2(R)) \quad (2.2.18)$$

and from (2.2.17) the GS coupling is

$$\begin{aligned} I_i &= \sum_{\alpha:\text{root}} \frac{1}{4} \alpha_i \text{sign}(\nu \cdot \alpha) (c_2(L) - c_2(R)) \\ &= \sum_{\nu \cdot \alpha > 0} \frac{1}{2} \alpha_i (c_2(L) - c_2(R)) \\ &= \rho_i (c_2(L) - c_2(R)), \end{aligned} \quad (2.2.19)$$

with ρ_i being the Weyl vector. The last ingredient we need is ‘‘the strange formula of Freudenthal and de Vries’’:

$$\eta^{ij} \rho_i \rho_j = \frac{1}{12} h_G^\vee d_G, \quad (2.2.20)$$

which reproduces the formula (2.2.12) with identifying $(c_2(L) - c_2(R))^2$ with $p_2(\text{SO}(5))$. Note that this method using CS coupling induced by massive fermions is applicable even to $\mathcal{F}_{E_{6,7,8}}^{(2,0)}$.

2.3. E-string theory

From this section we start to generalize the construction of $\mathcal{N}=(2,0)$ theories into $\mathcal{N}=(1,0)$ by introducing additional orientifolds, orbifolds, or branes which preserve half of the supersymmetry. First, we consider the $\mathcal{N}=(1,0)$ theory called E-string theory and its higher rank generalization. The theory can be most simply defined as a worldvolume theory of a zero-sized E_8 instanton in $E_8 \times E_8$ heterotic string [39], though here other frames related by string duality chains are convenient. After explaining some duality frames, we generalize the calculation of the anomaly polynomial to the E-string case.

2.3.1. Heterotic M-theory description of E-string theory

It is hard to find the tensor branch mode of the E-string theory defined as a zero-sized instanton in the heterotic string theory frame. To detect the tensor branch, we go to the M-theory frame with two Hořava-Witten domain walls [40, 41] which is dual to $E_8 \times E_8$ heterotic string. The Hořava-Witten domain wall, also known as the M9-brane, is the ten-dimensional fixed plane of the orientifold action

$$x^{10} \rightarrow -x^{10}, \quad C \rightarrow -C. \quad (2.3.1)$$

Hořava and Witten argued that the M-theory CS coupling (2.2.9) induces anomaly localized on the fixed plane, and therefore the plane should support a 10d matter system. The anomaly-inflow into the M9-brane can be canceled by a 10d $\mathcal{N}=1$ vector multiplet with gauge group E_8 . When the x^{10} direction is compactified, there are two M9-branes both have E_8 vectors, and the system, which is called heterotic M-theory, is considered to be the strong coupling limit of the $E_8 \times E_8$ heterotic string.

In heterotic M-theory, we can consider an M5-brane localized along x^{10} direction near one of the M9-branes as pictured in Figure 2.4. Since the M5 brane can be incorporated into the M9 brane as an E_8 instanton, the world volume theory on the M5 probing M9 is identified with the E-string theory. The instanton moduli space which make the M5-brane non-zero size instanton is recognized as the Higgs branch of the E-string theory. When the M5-brane is separated from the M9-brane, an M2 brane suspended between the M5- and M9-brane behaves as a massive string with mass proportional to the distance between the M5- and M9-brane. When the M5 is attached to the M9, the string becomes massless and the nontrivial SCFT arises. Since the M9 brane supports 10d E_8 vector field, the SCFT potentially have E_8 flavor symmetry. In addition to that, the SCFT possesses $SO(4) \sim SU(2)_R \times SU(2)_L$ symmetry coming from rotation of directions transverse to both M9 and M5. The $SU(2)_R$ subgroup is regarded as the R-symmetry of $\mathcal{N}=(1,0)$ algebra, and the remaining $SU(2)$ is a (non-R) flavor.

This construction can easily be generalized to the higher rank case, namely multiple M5-branes probing M9. We denote the rank N E-string theory, which corresponds to N M5s on M9, by $\mathcal{F}_N^{\text{Est}}$. On the tensor branch, there are N tensor modes coming from positions of M5 transverse to M9, and $N - 1$ hyper modes coming from positions of M5 tangent to M9. The center of mass hyper mode tangent to M9 is decoupled from $\mathcal{F}_N^{\text{Est}}$.

The higher rank theory has various RG flows as shown in Figure2.5. When $N - i$ of total N M5-branes on the M9 are moved away from the M9, the theory flows into the sum of $\mathcal{F}_{A_{N-i-1}}^{(2,0)}$,

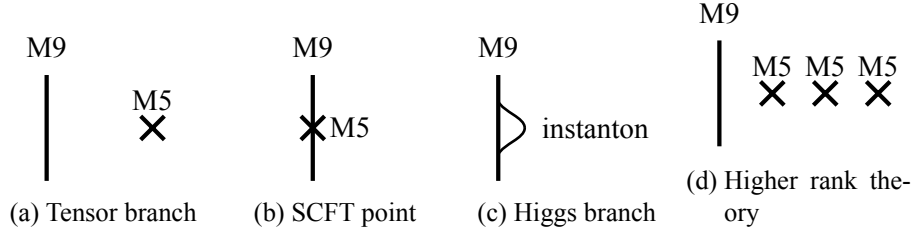

Figure 2.4.: The E-string theory is the worldvolume theory on an M5-brane probing an M9-brane. Higgs branch is identified with instanton moduli. The higher rank generalization refers to multiplet M5-branes probing M9.

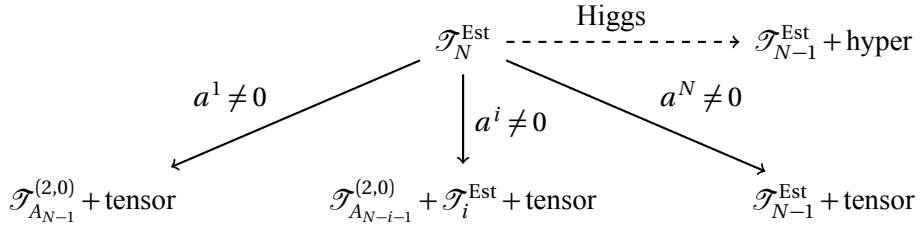

Figure 2.5.: RG flows from $\mathcal{T}_N^{\text{Est}}$. a_i denotes the tensor vev of i th tensor mode counting from the left of Figure 2.4d. On 1 dimensional subset of the tensor branch, the theory flows to sum of an $\mathcal{N}=(2,0)$ theory, an E-string theory and a Nambu-Goldstone tensor mode. On the Higgs branch, the theory flows to the E-string theory with less rank plus NG hyper modes.

$\mathcal{T}_i^{\text{Est}}$ and a Nambu-Goldstone tensor mode. For the Higgs branch, when one of M5s is dissolved into the M9, the theory flows into the E-string theory with one less rank accompanied by a NG hyper mode.

The charge matrix η^{ij} for $\mathcal{T}_N^{\text{Est}}$ is also determined by this M-theory construction as we did for $\mathcal{T}_{A_N}^{(2,0)}$. This time increasing the tensor branch parameter a^1 corresponds to moving M5 while fixing M9, not the middle point between M5 and M9. Thus, the dynamical string charge is the same as negative of the defect charge, namely $\eta = 1$. For higher rank theory, we have

$$\eta^{ij} = \begin{cases} 1 & i = j = 1 \\ 2 & i = j \neq 1 \\ -1 & |i - j| = 1 \\ 0 & \text{otherwise} \end{cases}. \quad (2.3.2)$$

Or, if we use the notation explained in Subsection 2.1.3.1 we have,

$$[\mathfrak{e}_8] \quad \emptyset \quad \mathfrak{su}(1) \quad \cdots \quad \mathfrak{su}(1) \\ 1 \quad 2 \quad \cdots \quad 2. \quad (2.3.3)$$

Let us determine the S^1 compactified theory of the rank N E-string theory. Upon compactifi-

cation, the M5 becomes D4 as before, and the M9 becomes $O8^-$ stacked with 7 D8-branes and 1 D8-brane separated from $O8^-$ so that the string coupling diverges at $O8^-$ [42]. When we introduce the Wilson line in terms of E_8 gauge field on M9 breaking E_8 down to $SO(16)$, in the Type IIA frame all the eight D8 branes are located on top of the $O8^-$. At the origin of the 5d Coulomb branch where the N D4-brane touches the $O8^-$ -D8 stack, the theory of the open strings on the D4-branes is the 5d $\mathcal{N}=1$ $USp(2N)$ gauge theory with 8 fundamental hypers charged under the $SO(16)$ flavor symmetry and a hyper in the irreducible antisymmetric representation of the gauge group. Thus, the potential E_8 flavor symmetry of the E-string theory cannot be trivial. The fundamentals come from D4-D8 strings, and the irreducible antisymmetric representation come from strings between D4 and themselves or their mirror.

2.3.2. Anomaly polynomials for E-string theories

The anomaly polynomial of the E-string theory is first obtained in [43] using anomaly inflow in the heterotic-M frame. The calculation is just a combination of the anomaly inflow for M5 and anomaly inflow for M9. Here, instead, we generalize the ‘‘field theoretical’’ method in 2.2.3.

In 2.2.3, we worked on a generic point of the tensor branch of $\mathcal{T}_G^{(2,0)}$. Here, since we already know $I[\mathcal{T}_{A_N}^{(2,0)}]$, it is enough to use the non-generic tensor branch flow $\mathcal{T}_N^{\text{Est}} \rightarrow \mathcal{T}_{A_N}^{(2,0)} + \text{tensor}$ with only a^1 having nonzero vev. Since the NG tensor mode have GS coupling with backgrounds, the total anomaly can be written as

$$I[\mathcal{T}_N^{\text{Est}}] = I[\mathcal{T}_{A_N}^{(2,0)}] + I[\text{tensor}] + I_{\text{GS}}. \quad (2.3.4)$$

Among the whole GS coupling $2\pi \int \eta^{ij} B_i \wedge I_j = 2\pi \int \eta_{ij} B^i \wedge I^j$ at a generic point, the contribution containing I^j , $j \neq 1$ is included in $I[\mathcal{T}_{A_N}^{(2,0)}]$, and therefore

$$I_{\text{GS}} = \frac{1}{2} \eta_{11} I^1 I^1 = \frac{N}{2} I^1 I^1. \quad (2.3.5)$$

Here we used the fact that the inverse matrix η_{ij} of the matrix (2.3.2) is

$$\eta_{ij} = N + 1 - \max(i, j). \quad (2.3.6)$$

To calculate I from 5d CS coupling induced by massive fermions, we compactify $\mathcal{T}_N^{\text{Est}}$ with Wilson line breaking flavor E_8 into its maximal rank subgroup $SO(16)$ so that we obtain the Lagrangian theory as explained. When compactified, the 6d flow induces the 5d Coulomb branch flow

$$USp(2N) \text{ with } 8 \text{ flavor} + 1 \text{ irred. antisymmetric} \rightarrow SU(N-1) \text{ MSYM} + \mathcal{N}=1 \text{ U}(1) \text{ vector}. \quad (2.3.7)$$

All the fundamental hypers becomes massive. They have $U(1)$ charge 1, and behaves as N copies of the vector representation of $SO(16)$. From the irreducible antisymmetric representation breaks down to the adjoint of $SU(N-1)$ leaving $N^2 - N$ massive hypers with $U(1)$ charge 2. There are also $N^2 + N$ massive vectors, also have $U(1)$ charge 2. As before, the fermions in massive hypers

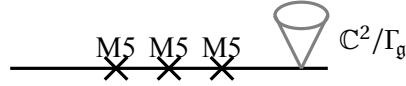

Figure 2.6.: M-theory brane construction of conformal matter $\mathcal{T}_N^{(\mathfrak{g},\mathfrak{g})}$. $N+1$ M5-branes are probing the singular locus of the ALE-orbifold.

are charged under $SU(2)_R$ and fermions in massive vectors are charged under $SU(2)_L$.

Collecting these informations and using the formula (2.2.16), one get

$$\eta_{11} I^1 = \frac{N^2}{2} \chi_4 + N I_4, \quad I_4 = c_2(F_{E_8}) + \frac{1}{4}(p_1(T) - 2(c_2(L) + c_2(R))) \quad (2.3.8)$$

with $\chi_4 = c_2(L) - c_2(R)$ being the Euler class of the $SO(4)$ bundle. We have used the fact that the embedding of $SO(16)$ into E_8 have the embedding index 1 and thus $c_2(F_{SO(16)}) = c_2(F_{E_8})$. Using (2.1.28), we get the anomaly polynomial

$$I[\mathcal{T}_N^{\text{Est}}] + I[\text{hyper}] = \frac{N^3}{6} \chi_4^2 + \frac{N^2}{2} \chi_4 I_4 + N \left(\frac{1}{2} I_4^2 - I_8 \right), \quad (2.3.9)$$

which agrees with the result of the anomaly inflow [43].

2.4. Conformal matters

To construct the E-string theory, we have considered the M-theory orientifold whose fixed-plane is 10-dimensional. Here, instead we would like to think on ALE-orbifold in M-theory, namely M-theory on $\mathbb{R}^{1,6} \times \mathbb{C}^2/\Gamma_{\mathfrak{g}}$ with Γ/\mathfrak{g} being the finite subgroup of $SU(2)$ labeled by a ADE root system \mathfrak{g} . In M-theory, an M2-brane can wrap a cycle of the resolved ALE-orbifold producing a 7d massive vector multiplet charged under the 7d $U(1)$ vector whose scalar superpartner is the size of the cycle. The charges of the massive vectors coming from M2-branes are determined by the Dynkin diagram associated to \mathfrak{g} , therefore in the limit where all cycles vanish there is the 7d \mathfrak{g} vector multiplet on the singular locus.

To construct 6d $\mathcal{N}=1$ SCFTs, we further introduce $N+1$ M5 branes as pictured in Figure. 2.6. The resulting SCFTs, after ignoring the center-of-mass tensor mode, are called conformal matters [13] and we call them $\mathcal{T}_N^{(\mathfrak{g},\mathfrak{g})}$. Each segment of the singular locus bounded by two M5-branes supports 6d dynamical \mathfrak{g} vector multiplet, and half-infinite singular loci support \mathfrak{g} flavor. Moving an M5 away from the singular locus corresponds to a Higgs vev. When all the M5-branes are located away from the singular locus, the theory flows into the $\mathcal{N}=(2,0)$ theory $\mathcal{T}_{A_N}^{(2,0)}$. The case with $N=0$, which is called minimal, the theory is very higgsable, meaning that it has a Higgs flow into some hypers. This property, which we call ‘‘higgsable to $\mathcal{T}_{A_N}^{(2,0)}$ ’’, become important in the next chapter. Consequently, the charge matrix η^{ij} should be the same as that of $\mathcal{T}_{A_N}^{(2,0)}$.

The finite group $\Gamma_{\mathfrak{g}}$ is a finite subgroup of the $SU(2)_L$ subgroup of the $SO(5)$ rotating transverse direction of M5s. When $\mathfrak{g} = A$, $U(1)$ subgroup of $SU(2)_L$ remains, though we will ignore it for simplicity in the following.

2.4.1.2. Anomaly polynomial

Since all tensor modes are coupled with vectors, the method in Subsection 2.1.3 can be applied. Just enumerating the naive contributions from the matter spectrum and doing square completion is needed, and the result agrees with (2.4.1).

For later use, we would like to determine each GS coupling I^i . Each I^i have the form

$$I^i = \tilde{\eta}^{iJ} c_2(F_J) + q_R^i c_2(R) + q_{\text{grav}}^i p_1(T). \quad (2.4.5)$$

where the index J runs both gauge and flavor algebras. Note that a gauge or flavor zero-sized instanton in the vectors on the singular locus can be regarded as an M2-brane inside the locus, and therefore q^{iJ} should be the charges of dynamical strings or defects corresponding to M2-branes. The charge can be read by the method we discussed in 2.2.1 and we get $\tilde{\eta}^{iJ} = \eta^{iJ}$ for gauge instantons and $\tilde{\eta}^{iJ} = -1$ for flavor instantons. Then, gauge anomaly cancellation condition forces $q_R^i = k, q_{\text{grav}}^i = 0$.

2.4.1.3. Weakly gauged Higgs branch of $\mathcal{F}_0^{(A_{k-1}, A_{k-1})}$

As said, the minimal conformal matter $\mathcal{F}_0^{(A_{k-1}, A_{k-1})}$, which is the worldvolume theory on an M5 probing $\mathbb{C}^2/\mathbb{Z}_k$, is just a bifundamental. How can we relate the mere bifundamental of $\mathfrak{su}(k)$ and the ALE $\mathbb{C}^2/\mathbb{Z}_k$ orbifold?

There are two different type of Higgs branchi of $\mathcal{F}_N^{(\mathfrak{g}, \mathfrak{g})}$: One is a Higgs vev preserving both $\mathfrak{g}_{L,R}$ flavors, and the other breaks. Then, the former corresponds to moving an M5 away from the singular locus, since the flavor gauge backgrounds living on the half-infinite singular locus as 7d vectors do not acquire masses in the process. This subbranch of the Higgs branch can be regarded as the Higgs branch of $\mathcal{F}_N^{(\mathfrak{g}, \mathfrak{g})}$ with both flavors infinitesimally weakly gauged. Therefore, when the number of M5s is one, the weakly gauged Higgs vev should be identified with position of the M5, and thus the weakly gauge Higgs branch of $\mathcal{F}_0^{(\mathfrak{g}, \mathfrak{g})}$ should be $\mathbb{C}^2/\Gamma_{\mathfrak{g}}$. For the $\mathfrak{su}(k)$ bifundamental $\mathcal{F}_0^{(A_{k-1}, A_{k-1})}$, this can be easily realized.

The scalars in the bifundamental are arranged into Q_a^i and \tilde{Q}_i^a each of which is in the representation $(\mathbf{k}, \bar{\mathbf{k}})$ and $(\bar{\mathbf{k}}, \mathbf{k})$ of the $\mathfrak{su}(k)^{\oplus 2}$ subalgebra of the whole flavor $\mathfrak{u}(2k)$. $\mathfrak{su}(k)^{\oplus 2}$ invariant combination of these scalars are

$$B = \det Q, \quad \tilde{B} = \det \tilde{Q}, \quad M = \frac{1}{k} \text{tr} Q \tilde{Q}. \quad (2.4.6)$$

The scalar components of each $\mathfrak{su}(k)$ flavor current multiplet, called moment maps, are

$$\mu_j^i = Q_j^a \tilde{Q}_a^i - M \delta_j^i, \quad \tilde{\mu}_b^a = Q_i^a \tilde{Q}_b^i - M \delta_b^a. \quad (2.4.7)$$

Since $\mu, \tilde{\mu}$ are charged under $\mathfrak{su}(k)^{\oplus 2}$, we would like to set $\mu = \tilde{\mu} = 0$, or $Q \tilde{Q} = M \mathbf{1}_{k \times k} = \tilde{Q} Q$ as an equation of $k \times k$ matrices with $\mathbf{1}_{k \times k}$ being the identity matrix. Taking determinant, we have

$$B \tilde{B} = M^k \quad (2.4.8)$$

which is the algebraic equation describing the singularity $\mathbb{C}^2/\mathbb{Z}_k$.

Instead, we can turn on the Higgs vev $\mu, \tilde{\mu}$ as

$$\mu = \tilde{\mu} = \text{diag}(m_1, \dots, m_k), \quad (2.4.9)$$

then the relation (2.4.8) becomes

$$B\tilde{B} = \prod_i^k (M + m_i), \quad (2.4.10)$$

which describes $\mathbb{C}^2/\mathbb{Z}_k$ with deformed complex structure. Therefore, the Higgs vev $\mu = \tilde{\mu}$ corresponds to the complex structure deformation of the M-theory geometry.

2.4.2. (D_k, D_k) conformal matter

2.4.2.1. Type IIA description and fractional M5

When $\mathfrak{g} = D_k$, we can still go to a Type IIA description. We again replace the ALE space with the ALF space of D_k type, which have the same singularity structure as the ALE space and asymptotically is $\mathbb{R}^3 \times S^1$. Since on the singular locus supports $\mathfrak{so}(2k)$ gauge group, in Type IIA frame we should see a stack of an $O6^-$ -plane and $2k$ D6-branes.

This time, an M5 brane probing the singular locus corresponds to *two* NS5 branes on the $O6^-$ -plane. The $O6$ -D6-NS5 system is known to engineer $\mathfrak{so}(2k)$ - $\text{usp}(2k-8)$ alternating quiver gauge theory, and therefore the type of $O6$ -plane should be different between left and right of an NS5. The number 8 comes from the D6-charge ± 4 of $O6^\pm$ -plane. Thus, one NS5 brane cannot escape from $O6$ -plane. On the other hand, in the M-theory frame an M5 brane can freely move away from the singularity, concluding that an M5 cannot be the M-theory uplifting of one NS5-brane trapped in an $O6$ -plane.

This fact implies that an M5 brane on the D-type ALE singularity can be fractionated; an M5-brane can split into two of half-M5-branes, each of which becomes an NS5-brane in the Type IIA frame: see Figure 2.8. A half of the segments of the singular locus of $\mathbb{C}^2/\Gamma_{D_k}$ should support $\text{usp}(2k-8)$ gauge rather than $\mathfrak{so}(2k)$. This is a ‘‘frozen’’ version of the $\mathbb{C}^2/\Gamma_{D_k}$ singularity, meaning that 8 of Kähler parameters are prohibited by a nontrivial discrete C -flux [44, 45]. The half-M5-brane is a domain wall between frozen and non-frozen singularities. We will see that this fractionation continues to the case with $\mathfrak{g} = \mathfrak{e}_{6,7,8}$.

We can also consider $N+1$ M5s probing $\mathbb{C}^2/\Gamma_{D_{k+8}}$ with the discrete C -flux. The theory has $\text{usp}(2k) \oplus \text{usp}(2k)$ flavor, and we denote it $\mathcal{F}_N^{(\text{usp}(2k), \text{usp}(2k))}$. It is also higgsable to $\mathcal{F}_{A_N}^{(2,0)}$.

2.4.2.2. Tensor branch structure

The vector and hyper matters are the $\mathfrak{so}(2k)$ - $\text{usp}(2k-8)$ quiver as said. The charge matrix η^{ij} can be read off from the Type IIA description, though a bit trickier than $\mathcal{F}_{A_N}^{(2,0)}$ case. Consider $\mathcal{F}_0^{(D_k, D_k)}$ case. In Type IIA frame, there are 2 NS5s that intersects with $O6$ -D6 stack. Between the NS5s, the type of the orientifold is $O6^+$ and the number of D6s is $2k-8$ (counting the mirror images), and outside the segment between NS5s the type of the orientifold is flipped to $O6^-$ and

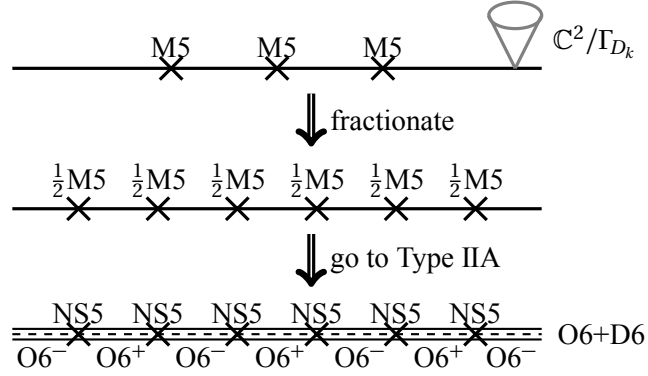

Figure 2.8.: M-theory and Type IIA brane construction of conformal matter $\mathcal{T}_N^{(D_k, D_k)}$. Since the D6 brane charges of $O6^\pm$ is different by eight, the number of D6 branes stacked with $O6^\pm$ should be adjusted so that the total D6 charge is the same between left and right side of each NS5 brane. Thus, the tensor branch theory is read to be an $\mathfrak{so}(2k)$ - $\mathfrak{usp}(2k-8)$ alternating quiver.

the number of D6s is $2k$. The point is that $O6^+$ -plane admits a half-D2-brane embedded within it while $O6^-$ does not¹⁴. Therefore, a minimal dynamical string corresponds to a half-D2-brane bridging NS5s while a minimal defect is created by half-infinite one (full) D2-brane, concluding $\eta^{11} = 1$. When $k = 4$, the gauge algebra is $\mathfrak{usp}(0) = \emptyset$, and thus the tensor branch structure of $\mathcal{T}_0^{(D_4, D_4)}$ is the same as that of $\mathcal{T}_1^{\text{Est}}$ therefore we might expect $\mathcal{T}_0^{(D_4, D_4)} = \mathcal{T}_1^{\text{Est}}$ identifying the $\mathfrak{so}(8) \oplus \mathfrak{so}(8)$ flavor of $\mathcal{T}_0^{(D_4, D_4)}$ as the subgroup of the \mathfrak{e}_8 flavor of $\mathcal{T}_1^{\text{Est}}$. Actually, both the $O6$ -NS5 system and the $O8$ -D8-NS5 system can be dualized into the same F-theory frame [13].

Next, let us think about $\mathcal{T}_0^{(\mathfrak{usp}(2k), \mathfrak{usp}(2k))}$. This time a defect comes from a half-infinite half-D2-brane, while a dynamical string does from a suspended full D2. The charge counting concludes $\eta^{11} = 4$. In the same manner, for general rank conformal matter $\mathcal{T}_N^{(D_k, D_k)}$, the tensor branch structure is

$$[\mathfrak{so}(2k)] \quad \mathfrak{usp}(2k-8) \quad \mathfrak{so}(2k) \quad \cdots \quad \mathfrak{usp}(2k-8) \quad \mathfrak{so}(2k) \quad \mathfrak{usp}(2k-8) \quad [\mathfrak{so}(2k)], \quad (2.4.11)$$

1 4 \cdots 1 4 1

and for $\mathcal{T}_N^{(\mathfrak{usp}(2k), \mathfrak{usp}(2k))}$ it is

$$[\mathfrak{usp}(2k)] \quad \mathfrak{so}(2k+8) \quad \mathfrak{usp}(2k) \quad \cdots \quad \mathfrak{so}(2k+8) \quad \mathfrak{usp}(2k) \quad \mathfrak{so}(2k+8) \quad [\mathfrak{usp}(2k)]. \quad (2.4.12)$$

4 1 \cdots 4 1 4

The Higgs branch to $\mathcal{T}_{A_N}^{(2,0)}$ is not open at a generic point of tensor branch of $\mathcal{T}_N^{(D_k, D_k)}$, but only where each half-M5 brane collides with another to form a full M5-brane, or in field theory language where $a^i = 0$ with $\mathfrak{g}_i = \mathfrak{usp}(2k-8)$. On that subbranch, which we call the “root to $\mathcal{T}_{A_N}^{(2,0)}$ ”,

¹⁴This can be understood from +-type orientifold projection realizes SO group on D2 branes while ---type projection does USp , and $USp(n)$ with odd n does not exist. Another reasoning can be found in the footnote in Subsection 2.4.3.

the tensor branch structure is

$$[\mathfrak{so}(2k)_L] \quad \mathfrak{so}(2k)_1 \quad \cdots \quad \mathfrak{so}(2k)_N \quad [\mathfrak{so}(2k)_L], \quad (2.4.13)$$

$\begin{matrix} 2 & \cdots & 2 \end{matrix}$

and between adjacent $\mathfrak{so}(2k)$ there are minimal conformal matters $\mathcal{F}_0^{(D_k, D_k)}$ behaving like “ $(\mathfrak{so}(2k), \mathfrak{so}(2k))$ bifundamentals”.

2.4.2.3. Anomaly polynomial

Calculating the anomaly polynomial for $\mathcal{F}_N^{(D_k, D_k)}$ from the tensor branch structure (2.4.11) and checking the agreement with (2.4.1) is easy. Instead, for $N \geq 1$, we can work on the subbranch (2.4.13) and calculate the anomaly polynomial as

$$I[\mathcal{F}_N^{(D_k, D_k)}] = \sum_{i=1}^N I[\mathfrak{so}(2k)_i \text{ vector}] + \sum_{i=0}^N I[\mathcal{F}_0^{(D_k, D_k)} \{\mathfrak{so}(2k)_i, \mathfrak{so}(2k)_{i+1}\}] + I_{\text{GS}} \quad (2.4.14)$$

where I_{GS} is the Green-Schwartz contribution only from the tensors remaining in (2.4.13). The bracket $\{\}$ specifies flavor or gauge algebras in (2.4.13) with $\mathfrak{so}(2k)_0 = \mathfrak{so}(2k)_L$, $\mathfrak{so}(2k)_{N+1} = \mathfrak{so}(2k)_R$. The Green-Schwartz coupled I_{GS} is identified to be $\frac{1}{2}\eta^{ij}I_iI_j$ with η^{ij} being the Cartan of A_N type and

$$\eta^{ij} = I^i = \tilde{\eta}^{iJ}c_2(F_J) + (2k-2)c_2(R), \quad (2.4.15)$$

where $\tilde{\eta}^{iJ}$ is the same as that in (2.4.5).

2.4.3. (E_k, E_k) conformal matter

The remaining conformal matters are of type E . As we have seen for the $\mathfrak{g} = D$ case, the tensor branch structure of $\mathcal{F}_0^{(\mathfrak{g}, \mathfrak{g})}$ encodes the fractionation of an M5 probing $\mathbb{C}^2/\Gamma_{\mathfrak{g}}$. Therefore studying $\mathcal{F}_0^{(E, E)}$ is interesting also from the M-theory perspective. Indeed, the fractionation pattern is much more complicated than $\mathfrak{g} = D$ case. We have investigated $\mathcal{F}_N^{(\mathfrak{g}, \mathfrak{g})}$ for $\mathfrak{g} = A, D$ using the Type IIA frame with which it is easy to read off the IR gauge theory description. For $\mathfrak{g} = E$, the generalization of the above Type IIA frame is not known, and therefore we should go along another way. In [13], the analysis was achieved by dualizing into the F-theory frame and blowing-up procedure. Here instead we insist on understanding in the M-theory frame.

2.4.3.1. Fractionation patterns and discrete C -flux on $\mathbb{C}^2/\Gamma_{E_{6,7,8}}$.

As said, an ALE singularity of type D, E can admit discrete C -flux, and we expect that a fractional M5-brane behaves as a domain wall between regions with different C -fluxes. The possible discrete C -flux is [44–46]

$$\int_{S^3/\Gamma_{\mathfrak{g}}} C = \frac{n}{d} =: r \pmod{1} \quad (2.4.16)$$

2. Six dimensional superconformal field theories

$$\begin{aligned}
 E_6: \frac{r}{\mathfrak{g}_r} & \parallel \begin{array}{c|c|c} \frac{1}{3}, \frac{2}{3} & & \frac{1}{2} \\ \hline \emptyset & & \mathfrak{su}(3) \end{array} & E_7: \frac{r}{\mathfrak{g}_r} & \parallel \begin{array}{c|c|c|c} \frac{1}{4}, \frac{3}{4} & & \frac{1}{3}, \frac{2}{3} & \frac{1}{2} \\ \hline \emptyset & & \mathfrak{su}(2) & \mathfrak{so}(7) \end{array} \\
 E_8: \frac{r}{\mathfrak{g}_r} & \parallel \begin{array}{c|c|c|c|c|c} \frac{1}{6}, \frac{5}{6} & & \frac{1}{5}, \frac{2}{5}, \frac{3}{5}, \frac{4}{5} & & \frac{1}{4}, \frac{3}{4} & \frac{1}{3}, \frac{2}{3} & \frac{1}{2} \\ \hline \emptyset & & \emptyset & & \mathfrak{su}(2) & \mathfrak{g}_2 & \mathfrak{f}_4 \end{array}
 \end{aligned}$$

Table 2.3.: Possible nontrivial values of discrete C -flux around $\mathbb{C}^2/\Gamma_{E_{6,7,8}}$ singularities and remaining gauge algebras after freezing.

where $S^3/\Gamma_{\mathfrak{g}}$ is an orbifolded unit sphere surrounding the singularity, d is one of the Dynkin label in the Dynkin diagram of type \mathfrak{g} and n is coprime with d . We refer the remaining gauge group after freezing with discrete C -flux r as \mathfrak{g}_r , and the singularity with the flux as \mathfrak{g}_r type singularity. We order the possible value of r by its value so that $r_0 = 0 < r_1 < r_2 < \dots < r_m = 1$ with m being the number of the possible r . The possible r and \mathfrak{g}_r are listed in Table 2.3 for $\mathfrak{g} = E_{6,7,8}$. Later we will give a derivation of this table.

Consider a domain wall between \mathfrak{g}_r and $\mathfrak{g}_{r'}$ type singularity. The M5-brane charge of the domain wall can be calculated by

$$\int_{S^4/\Gamma_{\mathfrak{g}}} dC = r' - r \pmod{1} \tag{2.4.17}$$

regarding the $S^4/\Gamma_{\mathfrak{g}}$ surrounding the domain wall as $S^3/\Gamma_{\mathfrak{g}}$ times an interval. Thus, we expect one M5 brane probing $\mathbb{C}^2/\Gamma_{\mathfrak{g}}$ split into n fractional branes with charge $r_i - r_{i-1}$. Therefore, the theory $\mathcal{T}_0^{(E_{6,7,8}, E_{6,7,8})}$ on a full M5-brane probing $\mathbb{C}^2/\Gamma_{E_{6,7,8}}$ has $m - 1$ tensor branch. The tensor branch structures for $\mathcal{T}_0^{(E_{6,7,8}, E_{6,7,8})}$ is

$$\mathcal{T}_0^{(E_6, E_6)}: [\mathfrak{e}_6] \ \emptyset \ \mathfrak{su}(3) \ \emptyset \ [\mathfrak{e}_6] \\
 \begin{array}{cccccc} & 6 & 1 & 3 & 1 & 6 \end{array}, \tag{2.4.18}$$

$$\mathcal{T}_0^{(E_7, E_7)}: [\mathfrak{e}_7] \ \emptyset \ \mathfrak{su}(2) \ \mathfrak{so}(7) \ \mathfrak{su}(2) \ \emptyset \ [\mathfrak{e}_8] \\
 \begin{array}{ccccccc} & 8 & 1 & 2 & 3 & 2 & 1 & 8 \end{array}, \tag{2.4.19}$$

$$\mathcal{T}_0^{(E_8, E_8)}: [\mathfrak{e}_8] \ \emptyset \ \emptyset \ \mathfrak{su}(2) \ \mathfrak{g}_2 \ \emptyset \ \mathfrak{f}_4 \ \emptyset \ \mathfrak{g}_2 \ \mathfrak{su}(2) \ \emptyset \ \emptyset \ [\mathfrak{e}_8] \\
 \begin{array}{ccccccccccc} & 12 & 1 & 2 & 2 & 3 & 1 & 5 & 1 & 3 & 2 & 2 & 1 & 12 \end{array}. \tag{2.4.20}$$

The numbers can be determined by F-theory technique [13] or can be read from M2-brane realization of strings/defects under an assumption about the minimal fractional M2-brane probing \mathfrak{g}_r singularity as we will see soon. Anomaly cancellation requires that between $\mathfrak{su}(2)$ and $\mathfrak{so}(7)$ there should be a $\frac{1}{2}(\mathbf{2}, \mathbf{8}_{\text{spin}})$ hyper, and between $\mathfrak{su}(2)$ and \mathfrak{g}_2 there should be a $\frac{1}{2}(\mathbf{2}, \mathbf{7} + \mathbf{1})$ hyper. The number under flavor algebras are used for generalization to $N \geq 1$. For example, the tensor branch structure of $\mathcal{T}_1^{(E_6, E_6)}$ is

$$\mathcal{T}_1^{(E_6, E_6)}: [\mathfrak{e}_6] \ \emptyset \ \mathfrak{su}(3) \ \emptyset \ \mathfrak{e}_6 \ \emptyset \ \mathfrak{su}(3) \ \emptyset \ [\mathfrak{e}_6] \\
 \begin{array}{cccccccc} & 1 & 3 & 1 & 6 & 1 & 3 & 1 \end{array}. \tag{2.4.21}$$

Though the anomaly cancellation also fixes the charge matrix η^{ij} , here we would like to read off from the M-theory brane physics. As we saw that for $\mathfrak{g} = D_k$ an M2-brane probing $\mathfrak{so}(2k)_{1/2} = \mathfrak{usp}(2k-8)$ singularity can be fractionated into half-M2-branes, it is also expected that an M2 probing \mathfrak{g}_r singularity with $r \neq 0$ is fractionated. Let us assume that the minimal charge of a fractional M2 is $\frac{1}{d}$ when $r = \frac{n}{d}$ ¹⁵. This assumption correctly reproduce the matrix η^{ij} .

For example, let us determine η^{22} of $\mathcal{F}_0^{(E_7, E_7)}$. $r_2 = \frac{1}{3}$, $\mathfrak{g}_2 = \mathfrak{su}(2)$, and the fractional M5-brane between r_1 and r_2 region have charge $\frac{1}{12}$, the one between r_2 and r_3 region have charge $\frac{1}{6}$. We call the former fractional M5 brane $M5_{12}$, and the latter $M5_{23}$. When the distance (normalized by ℓ_p^3) between $M5_{12}$ and $M5_{23}$ increases by Δa^2 fixing the center-of-mass of $M5_{12}$ and $M5_{23}$, $M5_{12}$ moves by $\frac{2}{3}\Delta a^2$ and $M5_{23}$ does $\frac{1}{3}\Delta a^2$, since the mass of a fractional M5-brane is proportional to its charge because of the supersymmetry. Therefore, while the change of the tension of a dynamical string coming from a fractional M2-brane with charge $\frac{1}{3}$ bridging $M5_{13}$ and $M5_{23}$ is $\frac{1}{3}\Delta a^2$, the tension of a defect coming from a half-infinite fractional M2-brane ending on $M5_{12}$ or $M5_{23}$ changes by $\frac{1}{4}\frac{2}{3}\Delta a^2 = \frac{1}{2}\frac{1}{3}\Delta a^2 = \frac{1}{6}\Delta a^2$, concluding $\eta^{22} = 2$.

2.4.3.2. Remarks on tensor branch physics

The tensor branch structures (2.4.18), (2.4.19), (2.4.20) contain tensor modes without a vector. As in the case of $\mathcal{F}_N^{(D_4, D_4)}$, those tensor modes are expected to become E-string theories when their vev are turned off keeping other vev non-zero. Therefore, the theory on that subbranch can be considered as a linear quiver gauge theory with non-perturbative E-string matters. Concretely, for $\mathcal{F}_0^{(E_6, E_6)}$, when vev without vector are deactivated, the structure (2.4.18) becomes

$$\mathcal{F}_0^{(E_6, E_6)} : \begin{array}{ccccccc} [\mathfrak{e}_6] & \emptyset & \mathfrak{su}(3) & \emptyset & [\mathfrak{e}_6] & \longrightarrow & [\mathfrak{e}_6] & \mathfrak{su}(3) & [\mathfrak{e}_6] \\ & & 1 & 3 & 1 & & & 1 & \end{array} . \quad (2.4.22)$$

The dynamical $\mathfrak{su}(3)$ couples with two $\mathcal{F}_1^{\text{Est}}$ through the embedding $\mathfrak{su}(3) \oplus \mathfrak{e}_6 \subset \mathfrak{e}_8$, and each remaining flavor \mathfrak{e}_6 becomes the left and right \mathfrak{e}_6 flavors. For $\mathcal{F}_0^{(E_7, E_7)}$ the same shrinking procedure gives

$$\mathcal{F}_0^{(E_7, E_7)} : \begin{array}{ccccccccccc} [\mathfrak{e}_7] & \emptyset & \mathfrak{su}(2) & \mathfrak{so}(7) & \mathfrak{su}(2) & \emptyset & [\mathfrak{e}_8] & \longrightarrow & [\mathfrak{e}_7] & \mathfrak{su}(2) & \mathfrak{so}(7) & \mathfrak{su}(2) & [\mathfrak{e}_8] \\ & & 1 & 2 & 3 & 2 & 1 & & & 1 & 3 & 1 & \end{array} . \quad (2.4.23)$$

The $\mathfrak{su}(2)$ gauges the subgroup of the flavor of a E-string theory $\mathcal{F}_1^{\text{Est}}$.

For $\mathcal{F}_0^{(E_8, E_8)}$, since the tensor branch structure (2.4.20) contains the substructure equivalent to that of $\mathcal{F}_2^{\text{Est}}$, after shrinking all the tensors without vectors we have

$$\begin{array}{ccccccc} [\mathfrak{e}_8] & \mathfrak{su}(2) & \mathfrak{g}_2 & \mathfrak{f}_4 & \mathfrak{g}_2 & \mathfrak{su}(2) & [\mathfrak{e}_8] \\ & & 1 & 2 & 3 & 2 & 1 \end{array} , \quad (2.4.24)$$

where each $\mathfrak{su}(2)$ vector couples with the $\mathfrak{su}(2)$ flavor of $\mathcal{F}_2^{\text{Est}}$, and between \mathfrak{g}_2 and \mathfrak{f}_4 there is an

¹⁵According to [46, 47], a frozen singularity in M-theory is dual to F-theory with \mathbb{Z}_d shift-orientifold, namely the \mathbb{Z}_d acts on a S^1 as $\frac{2}{d}\pi$ translation and on a plane as $\frac{2}{d}\pi$ rotation. A fractional M2 is dualized to a D3 wrapping $\frac{1}{d}$ of S^1 and trapped at the origin of the plane, which means that the fractional charge is $\frac{1}{d}$.

E-string theory $\mathcal{T}_1^{\text{Est}}$ with its $\mathfrak{g}_2 \oplus \mathfrak{f}_4 \subset \mathfrak{e}_8$ flavor subalgebra gauged.

A higher rank conformal matter $\mathcal{T}_N^{(\mathfrak{g},\mathfrak{g})}$ should be able to be Higgsed into $\mathcal{T}_{A_N}^{(2,0)}$ when the fractional branes are combined to form a full M5. This situation corresponds to all the tensor vev except for those coupled with \mathfrak{g} vectors are set to be zero. For the theory $\mathcal{T}_N^{(\mathfrak{g},\mathfrak{g})}$ to be higgsable to $\mathcal{T}_{A_N}^{(2,0)}$, the charge matrix should be the same as that of $\mathcal{T}_{A_N}^{(2,0)}$. To check this, an easy way is to recursively shrink down the tensor vev with $\eta^{ii} = 1$. For $\mathcal{T}_1^{(E_6, E_6)}$, this procedure goes

$$\begin{array}{cccccccccccccccc} [\mathfrak{e}_6] & \emptyset & \mathfrak{su}(3) & \emptyset & \mathfrak{e}_6 & \emptyset & \mathfrak{su}(3) & \emptyset & [\mathfrak{e}_6] & \longrightarrow & [\mathfrak{e}_6] & \mathfrak{su}(3) & \mathfrak{e}_6 & \mathfrak{su}(3) & \mathfrak{e}_6 & \longrightarrow & [\mathfrak{e}_6] & \mathfrak{e}_6 & [\mathfrak{e}_6] \\ & & 1 & 3 & 1 & 6 & 1 & 3 & 1 & & & 1 & 4 & 1 & & & & 2 & & \end{array} \quad (2.4.25)$$

One can also check that the similar but slightly longer procedure gives that the desired subbranch structures for $\mathcal{T}_1^{(E_{7,8}, E_{7,8})}$ are

$$\begin{array}{cccc} [\mathfrak{e}_7] & \mathfrak{e}_7 & [\mathfrak{e}_7] & [\mathfrak{e}_8] & \mathfrak{e}_8 & [\mathfrak{e}_8] \\ & 2 & & & 2 & \end{array}, \quad (2.4.26)$$

which are consistent with the fact that those theories are higgsable to $\mathcal{T}_{A_1}^{(2,0)}$. For $N \geq 2$, the same operation results in

$$\begin{array}{cccc} [\mathfrak{g}] & \mathfrak{g} & \cdots & \mathfrak{g} & [\mathfrak{g}] \\ & 2 & \cdots & 2 & \end{array}, \quad (2.4.27)$$

which is the root to $\mathcal{T}_{A_N}^{(2,0)}$.

2.4.3.3. T^3 compactification and frozen gauge algebras

Here we would like to understand the freezing pattern in Table 2.3 along the line of [14]. To do that, we consider T^3 compactification of $\mathcal{T}_0^{(\mathfrak{g},\mathfrak{g})}$. The M-theory space times is $\mathbb{R}^{1,2} \times T^3 \times \mathbb{R} \times \mathbb{C}^2 / \Gamma_{\mathfrak{g}}$, and an M5 wrapping T^3 probes the singularity. Regarding one dimension of T^3 as the M-circle, we get Type IIA on $\mathbb{R}^{1,2} \times T^2 \times \mathbb{R} \times \mathbb{C}^2 / \Gamma_{\mathfrak{g}}$ with a D4 wrapping T^2 on the singularity. After taking T-duality twice which transforms D4 into D2 and go up to M-theory, the space time becomes topologically the same as the starting point, but an M2 brane probing the singularity.

Since the singular locus filling $\mathbb{R}^{1,2} \times \mathbb{R} \times T^3$ supports the T^3 compactified 7d SYM with gauge group \mathfrak{g} , an M2 brane can be absorbed into the SYM as an instanton on $\mathbb{R} \times T^3$. We denote the coordinate on this \mathbb{R} by t (regarded as if it were ‘‘time’’). We can define the CS invariant $\text{CS}(t)$ along $\{t\} \times T^3$, and existence of an instanton requires $\text{CS}(\infty) - \text{CS}(-\infty) = 1$. If fractionation of an M5 in the original frame translated into that of a triply periodic instanton, the M5 charge in the original frame becomes the difference of the CS invariant. Thus, we expect a \mathfrak{g} -bundle on T^3 can admit fractional CS invariant.

Fractional CS invariant on T^3 can be realized by imposing nontrivial Wilson line along the three independent cycles of T^3 [48]. The Wilson line along T^3 determined by three elements $\vec{g} = (g_1, g_2, g_3)$ commuting each other of the Lie group G is, called a commuting triple. Let us denote the conjugacy class of \vec{g} by $[\vec{g}]$, and the set of $[\vec{g}]$ by $\mathcal{T}G$. We introduce an order into $\mathcal{T}G$ by the CS invariant $\text{CS}[\mathfrak{g}_i]$ modulo 1 on T^3 with Wilson line \vec{g} .

At $t = -\infty$, the Wilson line is trivial. Suppose that at $t = t_0$ a nontrivial Wilson line (g_1, g_2, g_3)

is suddenly turned on, then after shrinking T^3 the point $t = t_0$ looks to support and domain wall with charge $\text{CS}(t = t_0 + 0) - \text{CS}(t = t_0 - 0)$. At $t = t_0 + 0$, the gauge algebra \mathfrak{g} is broken to the commutant $\mathfrak{g}[\vec{g}]$ of $\vec{g} = (g_1, g_2, g_3)$. Therefore, at a generic point of the triply periodic instanton moduli, we have a 3d gauge theory with gauge algebra $\bigoplus_{[\vec{g}_i] \in \mathcal{T} \setminus \{(1,1,1)\}} \mathfrak{g}[\vec{g}_i]$.

From the data in [48], the possible values of $\text{CS}[\vec{g}_i]$ coincide with (2.4.16), and the corresponding remaining gauge algebra $\mathfrak{g}[\vec{g}_i]$ is the Langlands dual of algebra listed in Table 2.3 (though all algebras in Table 2.3 except for $\mathfrak{so}(7)$ are self-Langlands dual). This is because we did T-dual twice which effectively acts on the gauge algebra as an S-dual.

2.4.3.4. Anomaly and GS coupling

Using the tensor branch structures (2.4.22), (2.4.23), (2.4.24) after tensor vev in E-string subsystems are turned off and the information on $I[\mathcal{T}_N^{\text{Est}}]$ (2.3.9), it is tedious but straightforward to check (2.4.1) for $\mathcal{T}_0^{(E_{6,7,8}, E_{6,7,8})}$.

For general N , it is convenient to consider the configuration (2.4.27). As we saw in the case with $\mathfrak{g} = D_k$, the anomaly polynomial can be calculated by

$$I[\mathcal{T}_N^{(\epsilon_k, \epsilon_k)}] = \sum_{i=1}^N I[(\epsilon_k)_i \text{ vector}] + \sum_{i=0}^N I[\mathcal{T}_0^{(D_k, D_k)}\{(\epsilon_k)_i, (\epsilon_k)_j\}] + I_{\text{GS}} \quad (2.4.28)$$

with $(\epsilon_k)_i$ denoting the i th ϵ_k gauge algebra. One can also check that the GS coupling $I^i = \eta^{ij} I_j$ is

$$I^i = \eta^{ij} c_2(F_j) + h^\vee(\mathfrak{g}) c_2(R), \quad (2.4.29)$$

which is also valid for $\mathfrak{g} = A, D$.

2.4.4. Circle compactification and generalized base-fiber duality

Though a 6d $\mathcal{N}=(1,0)$ SCFT usually does not admit a Lagrangian description (at the origin of the tensor branch), its circle compactification into a 5d theory tends to have a Lagrangian even at the origin of the 5d Coulomb branch and can become weakly coupled on some parameter region. We have seen that $\mathcal{N}=(2,0)$ reduces to the MSYM, and an E-string theory reduces to a 5d $\mathcal{N}=1$ usp gauge theory with some matters when the flavor is appropriately broken by Wilson lines.

The conformal matters $\mathcal{T}_N^{(\mathfrak{g}, \mathfrak{g})}$ also have similar situation. Since all tensor modes are coupled with vectors on a generic point of the tensor branch, those vectors become strongly coupled at the origin and the compactified theory is expected to flow into a 5d fixed point ${}^{\text{5d}}\mathcal{T}_N^{(\mathfrak{g}, \mathfrak{g})}$. Thus, to have a 5d weakly coupled Lagrangian, all the gauge fields should become massive and decouple by introducing Wilson line.

The M-theory orbifold-brane construction again tells us about the 5d theory. Compactifying the M5s on a circle, we get the Type IIA configuration where $N+1$ D4 branes probing the orbifold singularity $\mathbb{C}^2/\Gamma_{\mathfrak{g}}$. This system is nothing but what considered in [49]. The Wilson line parameter corresponds to the expectation value of $b_i = \int_{\Sigma_i} B_{10d}$, the integration of the 10d NSNS 2-form B_{10d} over a vanishing cycle Σ_i . Their orbifold analysis concludes that the 5d theory is a quiver gauge theory whose quiver shape is the affine Dynkin diagram of type $\hat{\mathfrak{g}}$, with $\hat{\mathfrak{g}}$ being the affine

version of \mathfrak{g} . At each node of the affine Dynkin diagram there exists a 5d $\mathcal{N}=1$ vector multiplet with gauge algebra $\mathfrak{su}((N+1)d_i)$ where d_i is the Dynkin label corresponding to that node, and at each edge there sits a bifundamental. The gauge coupling $\frac{8\pi^2}{g_i^2}$ of the gauge group on the i th node is proportional to b_i , and the sum of the gauge couplings $\sum_i \frac{8\pi^2}{g_i^2}$ including the affine node is the inverse $\frac{1}{R_6}$ of the circle radius R_6 . A more detailed analysis will be made in Section 3.3.

2.4.5. Closing the flavors of $\mathcal{F}_N^{(\mathfrak{su}(k), \mathfrak{su}(k))}$

A conformal matter $\mathcal{F}_N^{(\mathfrak{g}, \mathfrak{g})}$ has two flavors $[\mathfrak{g}^{\oplus 2}]$ each of which couples with 7d \mathfrak{g} SYM. The boundary condition of the 7d SYM is the Dirichlet boundary condition, which preserves the \mathfrak{g} 7d gauge symmetry. Instead, we can impose a half-BPS Nahm-pole boundary condition which is specified by a nilpotent element μ of the complex algebra $\mathfrak{g}_{\mathbb{C}}$ [50]. The nilpotent orbits of left and right flavor algebras constitute a Higgs subbranch, and the Higgs flow defines a new 6d SCFT $\mathcal{F}_N^{(\mathfrak{g}, \mathfrak{g})}\{\mu_L, \mu_R\}$ after ignoring NG hyper modes. This operation is called (partial) closing.¹⁶ The theory only depends on the conjugacy classes of μ_L, μ_R . The flavor symmetries of this theory are commutants of μ_L, μ_R .

The tensor branch structure of $\mathcal{F}_N^{(\mathfrak{g}, \mathfrak{g})}\{\mu_L, \mu_R\}$ can also be determined using F-theory techniques, though we here analyze it using Type IIA brane construction for $\mathfrak{g} = A$ case along the line of [51–53]. For $\mathfrak{g} = D, E$ case, we will see some examples in Subsection 3.3.3. A systematic study is in [54].

A nilpotent orbit in $\mathfrak{su}(k)$ is determined by a $k \times k$ Jordan standard form, which is specified by a partition $Y = [y_1, y_2, \dots]$ of k with y_i being the size of the i th largest Jordan block. We also regard Y as a Young diagram whose i th column has height y_i . We denote the nilpotent orbit labeled by a Young diagram Y by \mathcal{O}_Y , and let $\mathcal{F}_N^{(A_{k-1}, A_{k-1})}\{Y_L, Y_R\}$ mean $\mathcal{F}_N^{(A_{k-1}, A_{k-1})}\{\mu_L, \mu_R\}$ with $\mu_{L,R} \in \mathcal{O}_{Y_{L,R}}$. A brane realization of the nilpotent Higgs vev can be achieved by introducing D8 branes into the Type IIA construction of $\mathcal{F}_N^{(A_{k-1}, A_{k-1})}$ as depicted in Figure 2.9.

The zero Higgs vev corresponds to $Y = [1^k]$, and we denote that Young diagram F . When μ is in the principal orbit, which is defined as the largest nilpotent orbit and corresponds to $Y = [k] =: C$, the flavor algebra is completely broken and the Higgsing is called the full-closing.

The situation is almost parallel to Type IIA brane construction of 4d $\mathcal{N}=2$ quiver gauge theory and its closing, and thus the tensor branch gauge theory can be identified using the Hanany-Witten effect as in 4d case¹⁷. A simple example is illustrated also in Figure 2.9. In general, the gauge groups can be calculated as follows. Let denote elements of the transpose Y^{\top} of Y as $Y^{\top} = [\ell_1, \dots, \ell_{y_1}]$ with $\ell_1 \geq \ell_2 \geq \dots \geq \ell_{y_1} > \ell_{y_1+1} := 0$, and define $m_i := \ell_i - \ell_{i+1}$, $L_i = \sum_{j=1}^i \ell_j$. Then when $N \geq y_1$, the tensor branch structure of $\mathcal{F}_N^{(\mathfrak{g}, \mathfrak{g})}\{F, Y\}$ is

$$\begin{array}{cccccccc} & & & [\mathfrak{su}(m_{y_1})] & [\mathfrak{su}(m_{y_1-1})] & \cdots & [\mathfrak{su}(m_2)] & \\ [\mathfrak{su}(k)_L] & \mathfrak{su}(k) & \cdots & \mathfrak{su}(k = L_{y_1}) & \mathfrak{su}(L_{y_1-1}) & \cdots & \mathfrak{su}(L_2) & \mathfrak{su}(L_1) & [\mathfrak{su}(m_1)], & (2.4.30) \\ & 2 & \cdots & 2 & 2 & \cdots & 2 & 2 & \end{array}$$

¹⁶This name is originally for flavors of 4d class S theories.

¹⁷One also can do a field theoretical analysis which we skip.

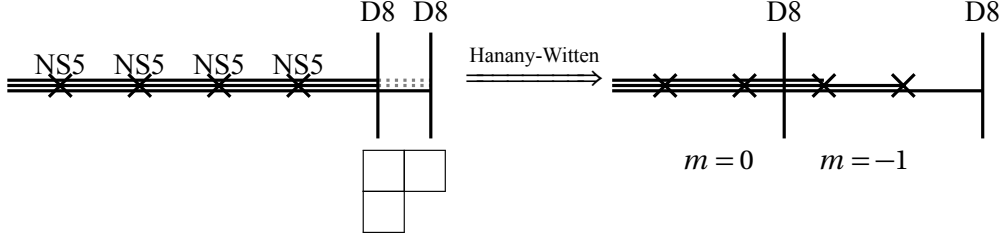

Figure 2.9.: Type IIA description of $\mathcal{F}_3^{(A_2, A_2)}\{F, Y_R\}$ with $F = [1, 1, 1]$, $Y_R = [2, 1]$. The right edge of the stack of D6s is ended on two D8s in the way specified by the Young diagram Y_R . The dotted lines represents D6 segments removed by the Higgsing operation. Moving the left D8 across two NS5 branes causes Hanany-Witten effect resulting in the left configuration. Between two D8s, the Romans mass m become -1 , meaning an NS5 tend to move to the right therefore balancing condition at the NS5 is changed as depicted. The tensor branch gauge theory can be read off from this configuration as an $\mathfrak{su}(3)_1$ - $\mathfrak{su}(3)_2$ - $\mathfrak{su}(2)$ quiver with 3 $\mathfrak{su}(3)_1$ fundamentals, one $\mathfrak{su}(3)_2$ fundamental and one $\mathfrak{su}(2)$ fundamental.

where $\mathfrak{su}(k)$ repeats $N + 1 - y_1$ times. When the charge matrix η^{ij} is an A -type Cartan, the gauge anomaly cancellation requires every $\mathfrak{su}(n)$ gauge algebras to have $2n$ flavors, and actually this condition is satisfied.

The gauge algebras near the right edge become smaller due to the Higgsing, and gradually becomes larger when going to the left. In particular, when $Y = C = [k]$ the above tensor branch structure is read as

$$\begin{array}{cccccccc} [\mathfrak{su}(k)] & \mathfrak{su}(k) & \cdots & \mathfrak{su}(k) & \mathfrak{su}(k-1) & \cdots & \mathfrak{su}(2) & \mathfrak{su}(1) \\ & 2 & \cdots & 2 & 2 & \cdots & 2 & 2 \end{array} . \quad (2.4.31)$$

Taking account of the $\mathfrak{u}(1)$ flavors ignored above, the total (non-anomalous) flavor algebra coming from the original $[\mathfrak{su}(k)_R]$ flavor before closing is the Levi subalgebra $\mathfrak{s}(\bigoplus_i \mathfrak{u}(m_i))$ of $\mathfrak{su}(k)$ whose element commutes with an element in \mathcal{O}_Y .

When both $[\mathfrak{su}(k)_{L,R}]$ are closed, the ‘‘ramp’’ structure appears on the both sides, and the total flavor algebra is the direct sum of two Levi subalgebras of $[\mathfrak{su}(k)_{L,R}]$ each specified by Y_L, Y_R , when $N + 1$ is larger than the sum of heights of two Young diagrams $Y_{L,R}$. Otherwise, the theory $\mathcal{F}_N^{(A_k, A_k)}\{\mu_L, \mu_R\}$ degenerates into $\mathcal{F}_N^{(A_{k'}, A_{k'})}\{Y'_L, Y'_R\}$ with some $k' < k$.

2.5. Higgsable to E-string theories

We have seen that an important class of theories $\mathcal{F}_N^{(\mathfrak{g}, \mathfrak{g})}$ which is higgsable to $\mathcal{N}=(2, 0)$ theories can be realized as $N + 1$ M5-branes probing $\mathbb{C}^2/\Gamma_{\mathfrak{q}}$ singularity. Here we introduce M9 in addition, constructing a class of theories higgsable to $\mathcal{F}_N^{\text{Est}}$ whose compactification will be investigated in 3.2. The system was studied in the reference [55] in the F-theory frame. The analysis here using M-theory and Type I' frames is motivated by (and most of them are essentially already presented

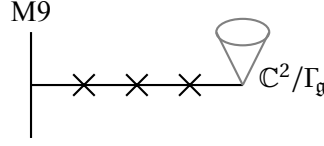

Figure 2.10.: M-theory construction of $\mathcal{T}_N^{(M9,g)}$ with $N = 3$.

in) [12, 13, 56].

2.5.1. M-theory construction

In [55], the theory of E_8 small instantons probing \mathbb{C}^2/Γ_g was investigated. Using the heterotic-M duality, the same system can be described as N M5 branes probing the intersection of M9 and the singular locus of \mathbb{C}^2/Γ_g as depicted in Figure 2.10. We call the theory $\mathcal{T}_N^{(M9,g)}$. The theory has $E_8 \oplus \mathfrak{g}$ flavor symmetry, where the former is charged under the 10d E_8 vector on M9 and the latter is charged under the 7d \mathfrak{g} vector of the half-infinite singular locus.

Moving N M5 branes away from the singularity along M9 we get the rank N E-string theory, which indicates that there is a Higgs branch flow

$$\mathcal{T}_N^{(M9,g)} \xrightarrow{\text{Higgs}} \mathcal{T}_N^{\text{Est}}. \quad (2.5.1)$$

Since $\mathcal{T}_N^{\text{Est}}$ is very-higgsable, $\mathcal{T}_N^{(M9,g)}$ is also very-higgsable.

Instead of the above Higgs branch flow, we can move N M5 branes away from M9 along the singular locus, which corresponds to a tensor branch flow. On the tensor branch, the M-theory system is very similar to that of the conformal matter $\mathcal{T}_{N-1}^{(g,g)}$. However, this time one side of the singular locus ends on M9, which might impose nontrivial boundary condition on the 7d SYM living on the singular locus. Therefore, supposing that boundary condition is the Nahm-pole boundary condition with nilpotent orbit \mathcal{O}_0 , the tensor branch flow is

$$\mathcal{T}_N^{(M9,g)} \xrightarrow{\text{tensor}} \mathcal{T}_{N-1}^{(g,g)}\{\mathcal{O}_0, F\}. \quad (2.5.2)$$

Then the tensor branch structure should look like

$$\begin{array}{cccc} [\mathfrak{e}_8] & \mathfrak{g}_1 & \mathfrak{g}_2 & \cdots \\ & 1 & \eta^{22} & \cdots \end{array} \quad (2.5.3)$$

with some subalgebra \mathfrak{g}_1 of \mathfrak{g} which commute with \mathcal{O}_0 , where the part

$$\begin{array}{ccc} [\mathfrak{g}_1] & \mathfrak{g}_2 & \cdots \\ & \eta^{22} & \cdots \end{array} \quad (2.5.4)$$

is the tensor branch structure of $[\mathcal{T}_{N-1}^{(\mathfrak{g},\mathfrak{g})}\{\mathcal{O}_0, F\}]$. In the following we denote this situation by

$$[\epsilon_8] \begin{array}{c} \mathfrak{g}_1 \\ 1 \end{array} [\mathcal{T}_{N-1}^{(\mathfrak{g},\mathfrak{g})}\{\mathcal{O}_0, F\}]. \quad (2.5.5)$$

To be consistent with the ϵ_8 flavor, the tensor mode with $\eta^{kk} = 1$ is supposed to produce the rank 1 E-string theory because we do not know another example of rank 1 6d SCFT with ϵ_8 flavor. Therefore, we conclude that $\mathfrak{g}_1 = \emptyset$ and the commutant of \mathcal{O}_0 does not contain non-abelian subgroup. Further, in [13, 55] the tensor branch structure is derived from the F-theory frame. From their result, the tensor branch structure of $\mathcal{T}_N^{(\text{M9}, \mathfrak{su}(k))}$ with $N \geq k$ is

$$[\epsilon_8] \begin{array}{cccccccc} \emptyset & \mathfrak{su}(1) & \mathfrak{su}(2) & \cdots & \mathfrak{su}(k) & \cdots & \mathfrak{su}(k) & [\mathfrak{su}(k)] \\ 1 & 2 & 2 & \cdots & 2 & \cdots & 2 & \end{array}, \quad (2.5.6)$$

which implies \mathcal{O}_0 is the maximal orbit meaning the full-closing of $[\mathfrak{g}_L]$. The result in the references are also consistent with \mathcal{O}_0 being the maximal orbit for $\mathfrak{g} = D_k, E_6$.¹⁸

As we did for $\mathcal{T}_N^{(\mathfrak{g},\mathfrak{g})}$, we can partially close the \mathfrak{g} flavor on the half-infinite singular locus. On the other hand, since the ϵ_8 flavor does not come from 7d SYM but 10d SYM on M9, the flavor admits different operation. In the M-theory construction, the M9 occupying $\mathbb{C}^2/\Gamma_{\mathfrak{g}}$ admits nontrivial E_8 flat bundle without breaking any supersymmetry. Those flat bundles are classified by homomorphisms

$$\rho_{E_8} : \Gamma_{\mathfrak{g}} \rightarrow E_8. \quad (2.5.7)$$

The ϵ_8 flavor is broken down to the subgroup commuting with the image of ρ_{E_8} . Therefore, we have defined a variant of $\mathcal{T}_N^{(\text{M9},\mathfrak{g})}$ labeled by a homomorphism ρ_{E_8} and a nilpotent orbit \mathcal{O} of \mathfrak{g} , and we denote it $\mathcal{T}_N^{(\text{M9},\mathfrak{g})}\{\rho_{E_8}, \mathcal{O}\}$. We abbreviate \mathcal{O} when \mathcal{O} is trivial. The flavor symmetry is $Z(\epsilon_8, \text{Im}\rho_{E_8}) \oplus Z(\mathfrak{g}, \mathcal{O})$, where $Z(\mathfrak{g}, \mathfrak{g}')$ is the subalgebra of \mathfrak{g} commuting with subspace $\mathfrak{g}' \subset \mathfrak{g}$.

A flat bundle with nontrivial ρ_{E_8} should also determine a certain boundary condition of the 7d \mathfrak{g} SYM at the intersection point, and therefore we expect there is a mysterious map

$$\{\text{hom. } \Gamma_{\mathfrak{g}} \rightarrow E_8\} \rightarrow \{\text{Nilpotent orbits of } \mathfrak{g}\}. \quad (2.5.8)$$

Denoting the image of ρ_{E_8} under the above map by $\mathcal{O}_{\rho_{E_8}}$, the tensor branch structure of $\mathcal{T}_N^{(\text{M9},\mathfrak{g})}\{\rho_{E_8}\}$ should be

$$[\mathfrak{f}] \begin{array}{c} \mathfrak{g}_1 \\ 1 \end{array} [\mathcal{T}_{N-1}^{(\mathfrak{g},\mathfrak{g})}\{\mathcal{O}_{\rho_{E_8}}, F\}], \quad (2.5.9)$$

with some flavor \mathfrak{f} and some gauge algebra \mathfrak{g}_1 . \mathfrak{f} should be a (possibly empty) subalgebra of $Z(\epsilon_8, \text{Im}\rho_{E_8})$, \mathfrak{g}_1 should be a simple subalgebra of $Z(\mathfrak{g}, \mathcal{O}_{\rho_{E_8}})$ or empty, and they should satisfy $Z(Z(\mathfrak{g}, \mathcal{O}_{\rho_{E_8}}), \mathfrak{g}_1) \oplus \mathfrak{f} = Z(\epsilon_8, \text{Im}\rho_{E_8})$.

The map (2.5.8) was investigated in [12], and determined for $\mathfrak{g} = \mathfrak{su}(k)$ with small k where $Z(\epsilon_8, \text{Im}\rho_{E_8})$ uniquely determines ρ_{E_8} , but in general it remains to be explored.

¹⁸The gauge algebras remaining in the ‘‘root to $\mathcal{T}_N^{\text{Est}}$ ’’ can be obtained by colliding simple punctures in class S of type D_k, E_6 . We do not have enough information about punctures in class S of type $\mathfrak{g} = E_{7,8}$.

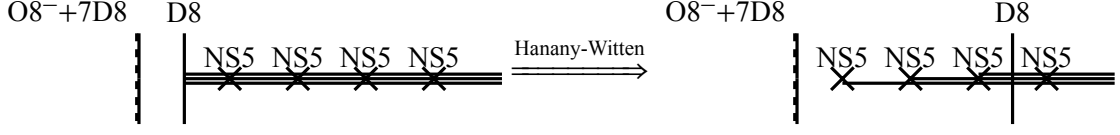

Figure 2.11.: Type I' brane construction of $\mathcal{T}_N^{(M9, su(k))}$ with $k=3, N=4$. After causing Hanany-Witten effect, the tensor branch structure (2.5.6) can be read off.

2.5.2. Type I' description for $\mathfrak{g} = \mathfrak{su}(k)$

Instead of directly determining the map (2.5.8), we can explore possible tensor branch structure for the case where $\mathfrak{g} = \mathfrak{su}$ which can be constructed in Type I' frame using the result of [51, 52], which is the strategy of [56].

2.5.2.1. $\mathfrak{g}_1 = \emptyset$ case with $O8^-$

First, we focus on the case with \mathfrak{g}_1 in (2.5.9) is empty, which was the interest of [15] and will be treated in 3.2. As said, the M9 in M-theory becomes the $O8^-$ -8D8 stack and the $\mathbb{C}^2/\Gamma_{\mathfrak{su}(k)}$ singularity becomes k of D6s in the Type I' frame. When ρ_{E_8} is trivial, the whole E_8 flavor should remain, and possible brane configuration with surviving E_8 symmetry constructed of by $O8^-$, 8D8s, k of D6s and NS5s is what is depicted in 2.11.

As a generalization, the k D6s can end on 8 D8-branes near the $O8^-$ with a pattern specified by a young diagram Y with no more than 8 columns, resulting in a theory $\mathcal{T}_N^{(M9, su(k))} \{\rho_{E_8}\}$ with a certain ρ_{E_8} which satisfies $\mathcal{O}_{\rho_{E_8}} = \mathcal{O}_Y$. The tensor branch structure is

$$[\mathfrak{e}_{9-\ell_1}] \quad \emptyset \quad \mathcal{T}_{N-1}^{(su(k), su(k))} \{Y, F\}. \quad (2.5.10)$$

where $[\mathcal{T}_{N-1}^{(su(k), su(k))} \{Y, F\}]$ is (2.4.30) (after flipping the left and the right). For small k , \mathfrak{e}_k means $\mathfrak{e}_5 = \mathfrak{so}(10)$, $\mathfrak{e}_4 = \mathfrak{su}(5)$, $\mathfrak{e}_3 = \mathfrak{su}(3) \oplus \mathfrak{su}(2)$, $\mathfrak{e}_2 = \mathfrak{su}(2) \oplus \mathfrak{su}(2)$, $\mathfrak{e}_1 = \mathfrak{su}(2)$. The \mathfrak{e}_8 flavor on M9 is broken down to

$$\mathfrak{e}_8 \supset \mathfrak{e}_{9-\ell_1} \oplus \mathfrak{su}(\ell_1) \supset \mathfrak{e}_{9-\ell_1} \oplus \mathfrak{s} \left(\bigoplus_{i=1}^{y_1} \mathfrak{u}(m_i) \right), \quad (2.5.11)$$

with $Y^\top = [\ell_1, \ell_2, \dots, \ell_{y_1}]$ and $m_i = \ell_i - \ell_{i+1}$. Note that the Levi subgroup which is the flavor of $\mathcal{T}_{N-1}^{(su(k), su(k))} \{Y, F\}$ also comes from the \mathfrak{e}_8 vector fields on M9 in the M-theory construction, not from the 7d vectors on $\mathbb{C}^2/\Gamma_{A_{k-1}}$ singular locus.

Combining with the closing of the $[\mathfrak{su}(k)]$ flavor, one can engineer a theory with tensor branch structure

$$[\mathfrak{e}_{9-u_1}] \quad \emptyset \quad \begin{array}{cccc} \mathfrak{su}(u_2) & \mathfrak{su}(u_3) & \cdots & \mathfrak{su}(u_N) \\ 1 & 2 & 2 & \cdots & 2 \end{array}, \quad (2.5.12)$$

where u_i satisfies $u_2 \leq 8$, $2u_i - u_{i-1} - u_{i+1} \geq 0$ ($u_1 = u_{N+1} := 0$). The Type I' construction is depicted in Figure 2.12. We call the theory $\mathcal{T}^{(M9, su)} \{u_i\}$. Their compactification will be investigated in Section 3.2.

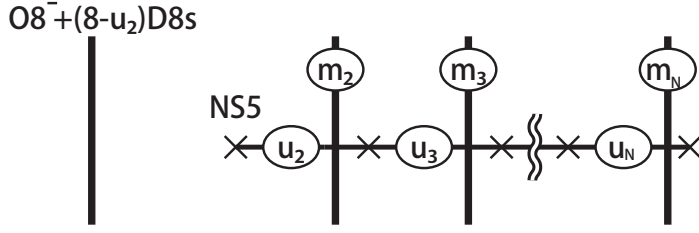

Figure 2.12.: Type I' brane construction of $\mathcal{T}_N^{(M9, su)}\{u_i\}$ [51, 52]. The \times mark represents an NS 5 brane, the horizontal line represents the stack of D6 branes, and the vertical lines represent D8 branes or the stack of $O8^-$ plane and D8 branes. The symbols in the circles are the numbers of the branes there. The m_i D8 branes intersecting with u_i D6 segments supports $su(m_i)$ flavor symmetry. The gauge anomaly cancellation requires $m_i = 2u_i - u_{i-1} - u_{i+1}$.

2.5.2.2. $O8^*$ -plane

In the discussion so far, we use the $O8^-$ plane in the brane construction. However, we can have an alternative orientifold 8-plane in Type I' brane engineering: $O8^*$ plane [42, 56, 57].

In [42, 57], the theory of a D4 brane probing the stack of $O8^-$ plane and $n \leq 8$ D8 branes was investigated. When the dilaton background at $O8^-$ diverges, the theory has su_{n+1} flavor symmetry and called E_{n+1} theory. Moreover, it was found that the E_2 theory has two distinct mass deformations which keep the dilaton background infinite; one is called E_1 theory with $\epsilon_1 = su(2)$ flavor symmetry and another is called \tilde{E}_1 theory with $\tilde{\epsilon}_1 = u(1)$ symmetry. The \tilde{E}_1 theory has further mass deformation to the E_0 theory which has no flavor symmetry.

This indicates that there are two distinct ways of splitting one D8 brane out of the stack of $O8^-$ plane and one D8 brane. They are realized using the different kind of orientifold 8-plane called $O8^*$ in [56] as follows:

$$\begin{aligned} O8^- + D8 &\rightarrow O8^-, D8 \\ &\searrow O8^* + D8, D8 \rightarrow O8^*, D8, D8. \end{aligned} \quad (2.5.13)$$

Here $+$ denotes the stack of two objects, while a comma means that the two objects exist separately. As a consequence, the flavor symmetry living on the $O8^-$ plane with the divergent dilaton background is ϵ_1 , while that for $O8^*+D8$ is $\tilde{\epsilon}_1$.

Using $O8^*$ -plane, we can engineer a theory with the tensor branch structure

$$[\tilde{\epsilon}_{9-u_1}] \quad \emptyset \quad su(u_2) \quad su(u_3) \quad \cdots \quad su(u_N) \\ 1 \quad 2 \quad 2 \quad \cdots \quad 2, \quad (2.5.14)$$

which we call $\mathcal{T}_*^{(M9, su)}\{u_i\}$. When $u_2 \leq 7$ the theory is identical to $\mathcal{T}^{(M9, su)}\{u_i\}$ since $O8^*+2D8=O8^-+D8$, therefore we impose $u_2 \geq 8$ when we write $\mathcal{T}_*^{(M9, su)}\{u_i\}$. Note that the two theories $\mathcal{T}^{(M9, su)}\{u_2 =$

$8, u_3 = 8, \dots\}$ and $\mathcal{F}_*^{(M9, su)}\{u_2 = 8, u_3 = 8, \dots\}$, which are

$$\begin{array}{ccccccccc} [\epsilon_1] & \emptyset & \mathfrak{su}(8) & \mathfrak{su}(8) & \cdots & [\tilde{\epsilon}_1] & \emptyset & \mathfrak{su}(8) & \mathfrak{su}(8) & \cdots \\ & & 1 & 2 & 2 & \cdots' & & 1 & 2 & 2 & \cdots' \end{array} \quad (2.5.15)$$

are different theories because the gauged $\mathfrak{su}(8)$ subalgebra of the ϵ_8 flavor of the E-string is different. In the former case the $\mathfrak{su}(8)$ subalgebra is embedded into ϵ_8 through the maximal subgroup $\mathfrak{su}(8) \oplus \mathfrak{su}(2)$, while in the later case the $\mathfrak{su}(8)$ subalgebra is embedded through the maximal subgroup $\mathfrak{su}(9)$.

2.5.2.3. $\mathfrak{g} = \mathfrak{su}, \mathfrak{g}_1 \neq \emptyset$ case

Here we will see some examples of the case with \mathfrak{g}_1 in (2.5.9) is not empty. To engineer such theories in Type I', D6 branes should intersect with the O8-plane. There are three distinct way of intersecting D6 with the O8:

1. Even number ($2k$) of D6 directly intersect with $O8^-$. The orientifold project the $\mathfrak{su}(2k)$ onto $\mathfrak{usp}(2k)$.
2. An NS5 brane sits on the intersecting point. The $\mathfrak{su}(k)$ gauge fields on the D6s ending on the $\frac{1}{2}$ NS5 possesses a rank 2 antisymmetric hyper.
3. D6 branes are intersecting with $O8^*$.

As an example of case 1., when $2k$ D6 intersect with $O8^-$ -8D8 stack coming from M9 and NS5 are probing the D6s, the theory looks

$$\begin{array}{ccccccc} [\mathfrak{so}(16)] & \mathfrak{usp}(2k) & \mathfrak{su}(2k) & \cdots & \mathfrak{su}(2k) & [\mathfrak{su}(2k)] & \\ & 1 & 2 & \cdots & 2 & & \end{array} \quad (2.5.16)$$

The $\mathfrak{usp}(2k)$ gauge group should have $2k + 8$ fundamental hypers because of the anomaly cancellation, with $2k$ of them being gauges by the neighboring $\mathfrak{su}(2k)$. When a $\frac{1}{2}$ NS5 is trapped at the intersection point (in this case the number of D6 can be odd), the theory becomes

$$\begin{array}{ccccccc} [\mathfrak{su}(8)] & \mathfrak{su}(k) & \mathfrak{su}(k) & \cdots & \mathfrak{su}(k) & [\mathfrak{su}(k)] & \\ & 1 & 2 & \cdots & 2 & & \end{array} \quad (2.5.17)$$

In this case the orientifold projection acts on a bifundamental hyper, therefore the leftmost $\mathfrak{su}(k)$ have $8 + k$ fundamental plus one rank-2 antisymmetric hyper. The gauge anomaly still cancels thanks to the element η^{11} of the charge matrix is 1.

The case 3. is intricate [56]. Here we only mention that using this configuration we can engineer, for example,

$$\begin{array}{cccc} [\mathfrak{su}(9)] & \mathfrak{su}(6) & \mathfrak{su}(6) & [\mathfrak{su}(6)] \\ & 1 & 2 & 2 \end{array} \quad (2.5.18)$$

where the leftmost $\mathfrak{su}(6)$ possesses 15 fundamentals and a half-hyper with rank-3 totally antisymmetric tensor representation.

Understanding those three cases from the M-theory point of view would be interesting. Those cases just come from different choices of the E_8 flat bundle ρ_{E_8} . The case 2. suggest that with some ρ_{E_8} the intersecting point of $\mathbb{C}^2/\mathbb{Z}_k$ singular locus and M9 have intrinsic M5 charge, but with other flat bundles realizing case 1. the intersection point does not have M5 charge.

3. Circle and torus compactifications

In Chapter 2, we have reviewed some basic properties of some examples of 6d SCFTs. In this chapter, we would like to investigate torus compactifications of the theories which appeared in the previous chapter.

As said in Chapter 1, the torus compactification of the $\mathcal{N}=(2,0)$ theory of type G gives 4d $\mathcal{N}=4$ SYM with gauge group G . In this case, two important properties are

1. The theory is superconformal at the origin of its moduli, and
2. the torus modulus τ is identified with the (exactly) marginal coupling τ of $\mathcal{N}=4$ SYM. In particular, the $SL(2, \mathbb{Z})$ modular group act as the S-duality on $\mathcal{N}=4$ SYM ¹.

It is not obvious these properties are universal for torus compactification of $\mathcal{N}=(1,0)$ theories.

Actually, in Section 3.1, for a very-higgsable theory, which is defined as a theory which is at a generic point of Higgs branch the system is gapped or hypers, we will find the following claim :

When a 6d $\mathcal{N}=(1,0)$ theory \mathcal{T} is very-higgsable, its torus compactification ${}^{4d}\mathcal{T}$ has a superconformal point on its moduli, and the torus modulus τ corresponds to an irrelevant operator on the superconformal fixed point. In particular, the $SL(2, \mathbb{Z})$ modular group acts trivially on the superconformal fixed point.

A well-known example is $\mathcal{T} = \mathcal{T}_N^{\text{Est}}$ [59]. In that case the compactified theory ${}^{4d}\mathcal{T}_N^{\text{Est}}$ is the higher rank generalization of the E_8 theory of Minahan-Nemeschansky, which does not have a marginal deformation. Another example of a very-higgsable theory is $\mathcal{T}_0^{(\mathfrak{g}, \mathfrak{g})}$, and we will observe that the torus compactified theory ${}^{4d}\mathcal{T}_0^{(\mathfrak{g}, \mathfrak{g})}$ can be identified with a class S theory of type \mathfrak{g} . Further, we study torus compactifications of theories which is higgsable to $\mathcal{T}_N^{\text{Est}}$ in Section 3.2 using web diagrams, and conclude the compactified theory can be also described as a class S theory of type A_{K-1} with some K when the theory satisfies certain additional conditions.

Finally, we will generalize the analysis for $\mathcal{T}_0^{(\mathfrak{g}, \mathfrak{g})}$ to general $\mathcal{T}_N^{(\mathfrak{g}, \mathfrak{g})}$ and its closing $\mathcal{T}_N^{(\mathfrak{g}, \mathfrak{g})} \{\mu_L, \mu_R\}$ in Section 3.3. Those theories are higgsable to $\mathcal{N}=(2,0)$ theory ²of type A_N , and the most of analysis will be also generalized to theories higgsable to $\mathcal{N}=(2,0)$ theories of D, E type. There, we will observe that:

¹ $\mathcal{N}=4$ SYM is not self-dual under the S-duality even when $G = SU(N)$ since its Langlands dual is $SU(N)/\mathbb{Z}_N$. The global data depends on choice of basis of cycle, and this is because the “meta”-ness of the A_{N-1} $\mathcal{N}=(2,0)$ theory [58]. This subtlety exists also for $\mathcal{N}=(1,0)$ theories which is not very-higgsable though we will not study further in this direction.

²Here, we focus on the case where we can go to the root to $\mathcal{N}=(2,0)$ theory by recursively shrinking tensor vev a^k with $\eta^{kk} = 1$. In other words, the root to $\mathcal{N}=(2,0)$ is the endpoint. A counterexample of this restriction is $\mathcal{T}_N^{(\text{usp}, \text{usp})}$.

when a 6d $\mathcal{N}=(1,0)$ theory \mathcal{T} is higgsable to $\mathcal{T}_G^{(2,0)}$, the torus compactification ${}^{4d}\mathcal{T}$ can be decomposed as

$${}^{4d}\mathcal{T} = {}^{4d}\mathcal{S}\{G\}/G_\tau \quad (3.0.1)$$

with some 4d $\mathcal{N}=2$ theory ${}^{4d}\mathcal{S}\{G\}$ with flavor G , where $/G_\tau$ denotes the 4d $\mathcal{N}=2$ gauging of the G flavor of ${}^{4d}\mathcal{S}\{G\}$ with marginal gauge coupling τ . The theory ${}^{4d}\mathcal{S}\{G\}$ is further decomposed as

$${}^{4d}\mathcal{S}\{G\} = ({}^{4d}\mathcal{U}\{G, H\} \times {}^{4d}\mathcal{V}\{H\})/H_{\text{IRF}} \quad (3.0.2)$$

where ${}^{4d}\mathcal{U}$, ${}^{4d}\mathcal{V}$ are certain 4d $\mathcal{N}=2$ SCFTs whose flavors are indicated in the bracket, and $/H_{\text{IRF}}$ denotes the gauging of the diagonal of H flavors of the two 4d SCFTs with an IR free gauge coupling. Therefore, in general, the 4d theory decouples into two SCFTs at the most singular point of the Coulomb moduli space³. When the tensor branch structure on the root to $\mathcal{T}_G^{(2,0)}$ includes $\mathfrak{su}(1)$ or \emptyset gauge algebra, ${}^{4d}\mathcal{V}\{H\} = \emptyset$ and $H = \emptyset$, and therefore ${}^{4d}\mathcal{S}\{G\} = {}^{4d}\mathcal{U}\{G\}$ is superconformal.

For $\mathcal{T}_N^{(A_k, A_k)}\{\mu_L, \mu_R\}$ and $\mathcal{T}_N^{(D_k, D_k)}\{\mu_L, \mu_R\}$, the theories ${}^{4d}\mathcal{U}$ and ${}^{4d}\mathcal{V}$ will be identified with certain class S theories, and in some cases we find that H and ${}^{4d}\mathcal{V}$ happens to be trivial. Therefore, in such cases, the two properties of compactification of $\mathcal{N}=(2,0)$ theories posed above are also satisfied and a generalization of Gaiotto's class S story to this case might be expected to exist.⁴

3.1. Compactification of very-higgsable theories: $\mathcal{T}_N^{\text{Est}}$ and $\mathcal{T}_0^{(g,g)}$

In this section, we investigate torus compactification ${}^{4d}\mathcal{T}$ of a 6d very-higgsable theory \mathcal{T} . Actually we would like to set a stronger condition than just being higgsable to free hypers, which is the following:

- All tensor vev can be turned off using only the procedure (2.1.37) recursively. Using the terminology introduced below (2.1.37), the endpoint is trivial.
- The charge matrix η^{ij} satisfies (2.1.31).

By the term very-higgsable, we mean these conditions in the following. An example with non-trivial defect group but being higgsable to a hyper is $\mathcal{T}_0^{(\text{usp}, \text{usp})}$. Further, we are going to use the empirical fact

- In the GS coupling $2\pi \int B_i \wedge I^i$ at a point in the contracted subspace of the tensor branch, the coefficient q_{grav}^i of $\frac{1}{4}p_1(T)$ in I^i is always $\eta^{ii} - 2$:

$$I^i \supset q_{\text{grav}}^i \frac{1}{4}p_1(T), \quad q_{\text{grav}}^i = \eta^{ii} - 2. \quad (3.1.1)$$

³Here we do not introduce Wilson lines along the torus. When generic Wilson lines are turned on, the situation is different [60].

⁴Instead, if we allow ourselves to turn on Wilson lines as we discussed in Subsection 2.4.4 for $\mathcal{T}_N^{(g,g)}$, the two properties are satisfied when compactified further to 4d, since the affine quiver is conformal in 4d. In fact the generalization to compactification by general Riemann surfaces with nontrivial flavor bundles gives 4d $\mathcal{N}=1$ SCFTs [61], and $g = A_{k-1}$ case which is called class S_k is somewhat extensively studied [60, 62].

which is derived from (2.1.31) and the empirical equation (2.1.25). As said there, this fact holds for all F-theory-constructible theories which includes all the known theories.

First, we study the torus compactification of a general very-higgsable theory \mathcal{T} , and prove

- The 4d theory has a superconformal point, and the SCFT does not have marginal coupling, and
- the 4d central charges a, c can be written as a linear combination of the coefficients of the 6d anomaly polynomial of \mathcal{T} .

In particular when $\mathcal{T} = \mathcal{T}_N^{\text{Est}}$, the formula obtained correctly recovers the known central charges of the rank N E_8 theory of Minahan and Nemeschansky.

Further, we consider the case of $\mathcal{T} = \mathcal{T}_0^{(\mathfrak{g}, \mathfrak{g})}$ and identify the compactified theory ${}^{4\text{d}}\mathcal{T}_0^{(\mathfrak{g}, \mathfrak{g})}$ as a class S theory of type \mathfrak{g} using string dualities in Subsection 3.1.2. We will also do consistency checks.

The contents of this section was originally appeared in [14] by the author of this thesis and his collaborators.

3.1.1. General properties and central charges of ${}^{4\text{d}}\mathcal{T}$

3.1.1.1. Subbranch \mathcal{H} of the 4d Coulomb branch

First we define a subbranch \mathcal{H} of the Coulomb branch of ${}^{4\text{d}}\mathcal{T}$. On the contracted subspace of the tensor branch of a very-higgsable theory \mathcal{T} , the tensor branch structure looks

$$\cdots \quad \mathfrak{g}_{k-1} \quad \mathfrak{g}_k \quad \mathfrak{g}_{k+1} \quad \cdots \quad (3.1.2)$$

$$\eta^{k-1, k-1} \quad 1 \quad \eta^{k+1, k+1} \quad \cdot$$

Between \mathfrak{g}_k and $\mathfrak{g}_{k\pm 1}$, there might be a Lagrangian or non-Lagrangian matter. For example, the structure expressed in the most right part of (2.4.22) is in the contracted space, and $\mathfrak{su}(3)$ and $[\mathfrak{e}_6]$ are coupled with an E-string through the embedding $\mathfrak{su}(3) \oplus \mathfrak{e}_6 \subset \mathfrak{e}_8$, which is non-Lagrangian.

Let us focus on the tensor mode a^k with $\eta^{kk} = 1$ associated with \mathfrak{g}_k . When compactified on T^2 , the tensor scalar a^k and the 4d scalar

$$b^k = \int_{T^2} B^k \quad (3.1.3)$$

coming from the 6d self-dual tensor field B^k forms a 4d Coulomb branch (complex) scalar

$$u \sim \exp(a^k + 2\pi i b^k). \quad (3.1.4)$$

This classical description of u is valid where $a^k \gg \text{vol}T^2$. The metric of the u -space is that of cylinder there, since b^k is identified with b^i by the 6d large gauge transformation. It is not obvious whether it is meaningful to talk about u where a^k is not large, because *a priori* the scalar

u can mix with the scalars coming from other tensors and scalars from 6d vector⁵. However, we will see later that the gauge algebra \mathfrak{g}_k is IR free in 4d, and thus we can separate u from other Coulomb parameters even quantum mechanically when the couplings of gauge fields with gauge algebra other than \mathfrak{g}_k are sufficiently weak. We let \mathcal{H} denote the complex one-dimensional subbranch spanned by u .

Further, the IR free-ness of \mathfrak{g}_k ensures that the structure of \mathcal{H} is invariant under the Higgs flow. Since Higgs branch does not admit quantum correction, the gauge field associated to \mathfrak{g}_k can be Higgsed. Then, the resulting theory is the T^2 compactified rank 1 E-string (plus other decoupled modes) [59]. Therefore, the special structure, in particular the positions of singularities, of the subbranch \mathcal{H} is the same as those of the Coulomb branch of the compactified E-string theory⁶.

3.1.1.2. Structure of \mathcal{H}

As said above, the structure of \mathcal{H} is universal among any tensor mode with $\eta^{kk} = 1$. Therefore, the problem of determining the structure of \mathcal{H} is reduced to the case of the rank 1 E-string theory $\mathcal{T}_1^{\text{Est}}$.

An easy way to capture the singularity structure of \mathcal{H} is to consider the brane construction of the E-string theory. The rank-1 E-string theory is the worldvolume theory on one M5 brane probing the M9. When compactified on S^1 , this M-theory system reduces to the Type IIA system with a stack of O8⁻ and eight of D8s coming from the M9 and one D4 coming from the M5. Further compactify and taking T-dual along that compactifying circle, we get a Type IIB system with 2 O7⁻, 8D7, one D3, which is depicted in Figure 3.1.

It is known from the F-theory analysis [63, 64] that 2 O7⁻-planes and 6 D7-branes can be combined to become an E_8 7-brane. Therefore, the restoration of the E_8 flavor of the E-string theory $\mathcal{T}_1^{\text{Est}}$ should correspond to this emergence of the E_8 -brane. As also illustrated in Figure 3.1, there are two additional D7-branes, and the position space of D3, which is identified with the Coulomb branch \mathcal{H} , is the cigar with one E_8 superconformal point and two of points where a D7-D3 free hyper emerges. We set the coordinates of those singular points to be $u = 0, 1, \lambda$ with a complex number λ by a linear fractional transformation on u fixing the infinity. Since the modulus τ of the torus is just related to the position λ of a D7 relative to the E_8 -brane, it does not affect the superconformal physics at the E_8 point.

Let us determine the special geometry of \mathcal{H} assuming that the associated Seiberg-Witten geometry is a torus fibration:

$$y^2 = x^3 + x f(u) + g(u). \quad (3.1.5)$$

The special coordinates a and its dual a_D are

$$\frac{da}{du} = \int_A \frac{dx}{y}, \quad \frac{da_D}{du} = \int_B \frac{dx}{y} \quad (3.1.6)$$

where A, B are cycles of the elliptic curve (3.1.5). Since the complex structure $\tau(u) = \frac{da_D}{da}$ should

⁵The Higgs branch is robust under the compactification thanks to eight supercharges, thus u does not mix with Higgs scalars.

⁶Instead, asymptotic behavior (3.1.4) is enough to constrain the special geometry as said in [14].

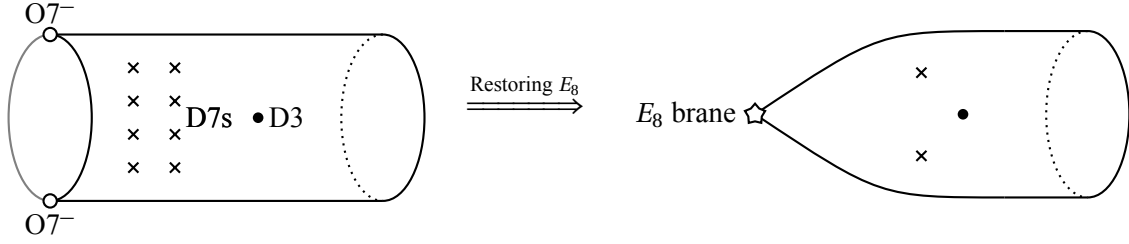

Figure 3.1.: Depiction of the brane realization of the Coulomb branch \mathcal{H} of rank 1 E-string theory. The left shows perturbative configuration where E_8 flavor is broken. The geometry depicted is a cylinder divided by the orientifold \mathbb{Z}_2 , and the gray curve between O7s are identified with the other curve between them. Colliding O7s and 6 D7, they non-perturbatively become an E_8 brane, and the Coulomb branch looks like the right picture. The position of the D3 corresponds to the Coulomb branch coordinate u , the E_8 -brane represents the superconformal point where the E_8 theory of Minahan and Nemeschansky is realized, and the remaining 2 D7-branes represents two free-hyper point in \mathcal{H} . Far away from the singular points, the Coulomb branch is a cylinder described by (3.1.4).

be asymptotically equal to the complex structure of the compactifying torus when $|u| \rightarrow \infty$, f, g behave as $f \rightarrow u^{4n}, g \rightarrow u^{6n}$ (ignoring the coefficient) with some integer n in the limit. The fact that the metric $ds^2 = \text{Im}(da^* da_D)$ on \mathcal{H} should be asymptotically cylinder, because of (3.1.4), determines n to be 1.

Therefore, $f(u), g(u)$ are polynomial of order 4, 6 respectively, and thus the discriminant $\Delta = 27f^2 + 4g^2$ has generically 12 zeros.⁷ However, when the E_8 flavor restores, we expect only three zeros are separated, and at the two hyper points the order of vanishing of Δ should be one. Imposing that the worst singularity sits at $u = 0$, the only possibility is

$$f(u) = u^4, \quad g(u) = u^5 + u^6, \quad (3.1.7)$$

up to coefficients.

The R-charge $R[u]$ of u at the superconformal point $u = 0$ can also be determined. From (3.1.5) and (3.1.7), the R-charge of x, y are

$$R[x] = \frac{5}{3}R[u], \quad R[y] = \frac{5}{2}R[u]. \quad (3.1.8)$$

The Seiberg differential λ is determined by $\frac{\partial \lambda}{\partial u} = \frac{dx}{y}$, and has R-charge 2. Thus, we have $2 - R[u] = R[x] - R[y] = -\frac{5}{6}R[u]$, and conclude $R[u] = 12$.

⁷ This number is related to the fact that an $O7^-$ is actually a non-perturbative bound-state of (1, 1) and (1, -1) 7-branes and thus there are 12 branes in the left of Figure 3.1. We are going to heavily use this fact in Section 3.2.

3.1.1.3. Method to calculating central charges

Here we briefly describe the method of calculating the 4d central charges of a 4d $\mathcal{N}=2$ SCFT with one-dimensional Coulomb branch, that was developed in [65]. The generalization to theories with multi dimensional Coulomb branch is straightforward and can be found in the reference. The method relies on the topological twisting of 4d $\mathcal{N}=2$ with (topologically nontrivial) background metric and flavor fields [66]. After twisting and integrating out massive modes, the partition function should look like

$$Z = \int_{\text{Coulomb branch}} [d\mu] A(u)^\chi B(u)^\sigma \prod_i C_i(u)^{n_i} Z_{\text{gen}}(\mu), \quad (3.1.9)$$

where $[d\mu]$ is the measure for the vector multiplet μ to which u belongs, $Z_{\text{gen}}(u)$ is the contribution coming from integrating out all modes but the multiplet μ , and topological invariants χ, σ, n_i are the Euler number, the signature $\frac{1}{3} \int p_1(T)$ and the instanton number $\int c_2(F_{\mathfrak{f}_i})$ with respect to the i th flavor \mathfrak{f}_i . $Z_{\text{gen}}(u)$ is calculated using the spectrum away from singular points in the Coulomb moduli. Other terms depending on backgrounds are prohibited by the topological invariance, and, to keep the twisted BRST invariance, the “functions” $A(u), B(u), C_i(u)$ of the Coulomb branch modulus u should be holomorphic. The reason of the quotation mark is explained just below.

As said in [66], the measure $[d\mu]$ is not invariant under the S-duality that maps the special coordinate a to a_D and vector multiplet fields μ to μ_D , but

$$[d\mu] = \tau^{-\frac{\chi}{2}} [d\mu_D], \quad \tau = \frac{da_D}{da}. \quad (3.1.10)$$

For the partition function Z to be invariant, the “function” $A(u)^\chi$ should absorb this modular anomaly, therefore $A(u)$ is actually a function on the $\text{SL}(2, \mathbb{Z})$ cover of the Coulomb branch determined by the torus fibration on it (B, C are also not single valued, but still functions on a finite cover). Therefore, we can write $A(u)$ as

$$A(u) = \hat{A}(u) \left(\frac{d\tau}{du} \right)^{\frac{1}{4}} \quad (3.1.11)$$

with $\hat{A}(u)$ being invariant under the S-duality, since

$$\left(\frac{d\tau_D}{du} \right)^{\frac{1}{4}} = \tau^{-\frac{1}{2}} \left(\frac{d\tau}{du} \right)^{\frac{1}{4}} \quad (3.1.12)$$

where $\tau_D = -\frac{1}{\tau}$.⁸

At a superconformal point $u = u_*$, the $\mathcal{N}=2$ $\text{U}(1)_R$ and $\text{SU}(2)_R$ symmetries should restore, and their (non-gauge) ’t Hooft anomalies are known to be related to conformal central charges a, c and flavor levels k_i with respect to flavor algebras \mathfrak{f}_i [67–69]. For $\mathcal{N}=2$ theories, the $\text{U}(1)_R$ -grav²,

⁸In fact, in general $A(u)$ though to be equal to $(\frac{\partial u}{\partial a})^{\frac{1}{2}}$. The later calculation will be simplified when this formula is assumed [65].

$U(1)_R$ - $SU(2)_R^2$ and $U(1)_R$ - f_i^2 't Hooft anomalies is related to the a, c, k_i as

$$d \star J_{U(1)_R} = 2(c - a)p_1(T) + 4(c - 2a)c_2(R) + \sum_i k_i c_2(F_i). \quad (3.1.13)$$

This equation is for the untwisted theory, and the twisting forces

$$c_2(R) = -\frac{1}{2}\chi_4 - \frac{1}{4}p_1(T) \quad (3.1.14)$$

with χ_4 being the Euler density. Therefore, after twisting, the anomaly (3.1.13) becomes

$$d \star J_{U(1)_R} = 2(2a - c)\chi_4 + c p_1(T) + \sum_i k_i c_2(F_i). \quad (3.1.15)$$

Comparing the variation $\delta \log Z$ obtained from this anomaly equation and from the equation (3.1.9) around the considered superconformal point, we obtain

$$a = \frac{1}{4}R[A|u_*] + \frac{1}{6}R[B|u_*] + a_{\text{gen}} \quad (3.1.16)$$

$$c = \frac{1}{3}R[B|u_*] + c_{\text{gen}} \quad (3.1.17)$$

$$k_i = R[C|u_*] + k_{i,\text{gen}} \quad (3.1.18)$$

where $a_{\text{gen}}, c_{\text{gen}}, k_{i,\text{gen}}$ are contribution from $Z_{\text{gen}}(u)$ and $R[A, B, C|u_*]$ are the charges of A, B, C with respect to the $U(1)_R$ restored at $u = u_*$. We define $\delta a_p, \delta c_p, \delta k_{i,p}$ by the difference between the central charges of the CFT arises at $u = p$ and $a_{\text{gen}}, c_{\text{gen}}, k_{i,\text{gen}}$.

3.1.1.4. Central charges of the E_8 theory of Minahan and Nemeschansky

Next, let us derive the central charges of the superconformal point of T^2 compactified $\mathcal{F}_1^{\text{Est}}$, as a warming up, by investigating the behaviors of the functions A, B, C defined above. We will almost repeat the calculation appeared in [65] though slightly change it to fit with the later calculation. We let A_E, B_E, C_E denote the functions A, B, C for the case of $4d \mathcal{F}_1^{\text{Est}}$. Soon we generalize this analysis to general very-higgsable theories. Note that since the $U(1)_R$ symmetry at the superconformal point is emergent at low-energy, we cannot obtain the 4d anomaly polynomial just integrating the 6d anomaly polynomial. However, the method we have reviewed above enables us to calculate 4d central charges a, c , which are linearly related with coefficients of the 4d anomaly polynomial by supersymmetry. The necessary ingredients are using the SW geometry of \mathcal{H} and the 6d GS coupling

$$2\pi \int B \wedge I, \quad I = c_2(F_{E_8}) - c_2(R) + \frac{1}{4}p_1(T). \quad (3.1.19)$$

The asymptotic behavior of the functions A_E, B_E, C_E around $|u| \sim \infty$ can be easily read from the GS coupling (3.1.19). Upon compactification and twisting the GS coupling becomes the 4d

coupling

$$\int I \log u, \quad I = \frac{1}{2} \chi_4 + \frac{1}{2} p_1(T) + c_2(F_{E_8}) \quad (3.1.20)$$

where $|u| \sim \infty$, and therefore the asymptotic behaviors of the functions A, B, C are determined to be

$$A_E \sim u^{\frac{1}{2}}, \quad B_E \sim u^{\frac{3}{2}}, \quad C_E \sim u \quad (\text{where } |u| \sim \infty). \quad (3.1.21)$$

Since B_E, C_E are free from modular anomaly, it is easy to determine their behaviors around the superconformal point from the argument principle. At $u = p = 1, \lambda$, just a massless hyper arises; therefore, we have $\delta_p a = \frac{1}{24}$, $\delta_p c = \frac{1}{12}$, $\delta_p k = 0$, $R[u] = 2$. From (3.1.16),(3.1.17),(3.1.18), we get

$$\text{ord}_p A_E = 0, \quad \text{ord}_p B_E = \frac{1}{8}, \quad \text{ord}_p C_E = 0 \quad (3.1.22)$$

for the hyper points $p = 1, \lambda$ with ord_p meaning the order of the zero at p . Thus, from (3.1.21), the argument principle says

$$\text{ord}_0 B_E = \frac{5}{4}, \quad \text{ord}_0 C_E = 1. \quad (3.1.23)$$

Then, from (3.1.17),(3.1.18) and the fact $R[u|0] = 12$, we have

$$\delta_0 c = 5, \quad \delta_0 k = 12. \quad (3.1.24)$$

To use the argument principle for $A_E(u)$, we should know the behavior of $\frac{d\tau}{du}$ around $u = 0, 1, \lambda, \infty$ which can be determined only by the special geometry of \mathcal{H} . Around the infinity, the j -invariant $j = \frac{4f^3}{\Delta}$ behaves like $j \sim 1 + u^{-1}$ (ignoring coefficients), and the function $\tau(u)$ goes to the non-singular $\tau(\infty)$ which is equal to the modulus of the compactifying torus; therefore the asymptotic behavior of $\frac{d\tau}{du}$ is

$$\frac{d\tau}{du} = \frac{d\tau}{dj} \frac{dj}{du} \sim u^{-2}, \quad (u \sim \infty). \quad (3.1.25)$$

Around the hyper points $u \sim p = 1, \lambda$, $\tau \sim \log(u - p)$ [70] from the one-loop computation. Near the E_8 superconformal point $u \sim 0$, the j invariant behaves $j \sim u^2$. There is a formula for τ :

$$\tau \propto \frac{{}_2F_1(\frac{1}{6}, \frac{5}{6}, 1; 1 - \alpha)}{{}_2F_1(\frac{1}{6}, \frac{5}{6}, 1; \alpha)} \quad (3.1.26)$$

with $j = \frac{1}{4\alpha(1-\alpha)}$ and the hypergeometric function ${}_2F_1$. Using the asymptotic behavior of the hypergeometric function which is ${}_2F_1(a, b, c; z) \sim z^{-a} + z^{-b}$ where $z \sim \infty$, we have

$$\frac{d\tau}{du} \sim u^{-\frac{1}{3}}, \quad (u \sim 0). \quad (3.1.27)$$

Then it is straightforward to find the orders of the function $\hat{A}_E(u) = A_E(\frac{d\tau}{du})^{-\frac{1}{4}}$. From (3.1.21),(3.1.22)

and the behavior of $\frac{d\tau}{du}$, we have

$$\hat{A}_E \sim u, \quad (u \sim \infty), \quad \text{ord}_p \hat{A}_E = \frac{1}{4}, \quad (p = 1, \lambda), \quad (3.1.28)$$

concluding

$$\text{ord}_0 \hat{A}_E = \frac{1}{2}, \quad \text{ord}_0 A_E = \frac{5}{12}, \quad R[A_E|0] = 5. \quad (3.1.29)$$

Substituting obtained R-charges $R[A_E, B_E, C_E|0]$ and $a_{\text{gen}} = \frac{5}{24}, c_{\text{gen}} = \frac{1}{12}$ coming from the vector multiplet μ , which is the only massless modes at a generic point, into (3.1.16),(3.1.17),(3.1.18), we obtain the central charges of the superconformal point of ${}^{\text{4d}}\mathcal{T}_1^{\text{Est}}$, which is thought to be the E_8 theory of Minahan and Nemeschansky, as

$$a = \frac{95}{24}, \quad c = \frac{31}{6}, \quad k_{E_8} = 12. \quad (3.1.30)$$

This agrees with the holographic calculation [71], although it is not completely sure that the holographic calculation is valid for $N = 1$.

3.1.1.5. Recursive calculation of 4d central charges

Now, we are ready to compute the central charges a, c, k_i for general T^2 compactified very-higgsable theory ${}^{\text{4d}}\mathcal{T}$. We are going to recursively prove the following proposition $P[N]$:

- $P[N]$: For any very-higgsable theory \mathcal{T} with rank (the number of tensor modes) less than or equal to N , the 4d central charges of the compactified theory ${}^{\text{4d}}\mathcal{T}$ is

$$\begin{aligned} a &= 24\alpha - 12\beta - 18\gamma \\ c &= 64\alpha - 12\beta - 8\gamma \\ k_i &= 48\kappa_i, \end{aligned} \quad (3.1.31)$$

where $\alpha, \beta, \gamma, \kappa_i$ are the coefficients of the 6d anomaly polynomial $I[\mathcal{T}]$ defined as

$$I[\mathcal{T}] \supset \alpha p_1(T)^2 + \beta p_1(T)c_2(R) + \gamma p_2(T) + \sum_i \kappa_i p_1(T)c_2(F_i). \quad (3.1.32)$$

The (3.1.31) can be directly checked for free hypers, tensors, vectors. In particular, the proposition $P[0]$ holds, since a free hyper is the very-higgsable theory.

To prove $P[N + 1]$ with assuming $P[N]$, we consider a rank $N + 1$ very-higgsable theory \mathcal{T}_+ . Because of being very-higgsable, there is a one-dimensional subspace of the tensor branch of \mathcal{T}_+ where the theory looks like

$$[\text{f}] \quad \mathfrak{g} \quad \mathcal{T} \\ 1 \quad (3.1.33)$$

with some (possibly empty) gauge algebra \mathfrak{g} and a rank N very-higgsable theory \mathcal{T} (possibly consists of multiple coupled component) coupled with the tensor mode (a^k, B^k) with $\eta^{kk} = 1$. When $\mathfrak{g} \neq \emptyset$ the rank N theory \mathcal{T} should have \mathfrak{g} flavor and gauged by the dynamical vector

multiplet, while if $\mathfrak{g} = \emptyset$ a defect of \mathcal{T} should be charged under the tensor mode B^k so that after shrinking a^k we get the coupled SCFT \mathcal{T}_+ .

Then, first we prove that \mathfrak{g} is IR free in 4d when $\mathfrak{g} \neq \emptyset$, which was postponed to prove, using the formula (3.1.31) for \mathcal{T} . The GS coupling of B^k is

$$2\pi \int B^k \wedge I, \quad I = -c_2(F_{\mathfrak{g}}) + c_2(F_{\mathfrak{f}}) + d c_2(R) + \frac{1}{4} p_1(T) \quad (3.1.34)$$

from (2.1.16) and the empirical assumption (3.1.1). The 6d gauge anomaly cancellation condition for \mathfrak{g} tells that

$$I[\mathfrak{g}] + I[\mathcal{T}] + \frac{1}{2} I^2 \supset \left(-\frac{h_{\mathfrak{g}}^{\vee}}{48} + \kappa_{\mathfrak{g}} - \frac{1}{16}\right) p_1(T) c_2(F_{\mathfrak{g}}) = 0. \quad (3.1.35)$$

Using $P[N]$, the 4d flavor central charge $k_{\mathfrak{g}}^{4d\mathcal{T}}$ of $4d\mathcal{T}$ is $k_{\mathfrak{g}}^{4d\mathcal{T}} = 4h_{\mathfrak{g}}^{\vee} + 12$ therefore the beta function of \mathfrak{g} in 4d on a generic point is (positively) proportional to

$$k_{\mathfrak{g}}^{4d\mathcal{T}} - 4h_{\mathfrak{g}}^{\vee} = 12 \geq 0, \quad (3.1.36)$$

and thus the gauge field with algebra \mathfrak{g} is IR free in 4d.

Knowing that \mathfrak{g} is IR free if not empty, we can isolate the subbranch \mathcal{H} of the 4d Coulomb branch spanned by the complex Coulomb scalar u coming from (a^k, B^k) , and the SW structure of \mathcal{H} is identified with that of $4d\mathcal{T}_1^{\text{Est}}$, as seen in the previous part of this subsection. Therefore, we can repeat the analysis for $4d\mathcal{T}_1^{\text{Est}}$ that we have already done. The only deference here from the previous case is that the coefficient of $c_2(R)$ in I can be different from that in (3.1.19). The values $\delta_0 a, \delta_0 c, \delta_0 k$ are now

$$\delta_0 a = \frac{3}{4} - 3d, \quad \delta_0 c = 2 - 3d, \quad \delta_0 k_{\mathfrak{f}} = 12, \quad \delta_0 k_{\mathfrak{g}} = -12. \quad (3.1.37)$$

The total $k_{\mathfrak{g}}$ is 0 at the superconformal point, which is consistent with the fact that at the point the R-symmetry should be non-anomalous. The difference of anomaly polynomials of \mathcal{T} and \mathcal{T}_+ is

$$\begin{aligned} I[\mathcal{T}_+] - I[\mathcal{T}] &= I[\mathfrak{g}] + I[\text{tensor}] + \frac{1}{2} I^2, \\ \frac{1}{2} I^2 &\supset \frac{1}{32} p_1(T)^2 + \frac{1}{4} d p_1(T) c_2(R) + \frac{1}{4} c_2(F_{\mathfrak{f}}), \\ &=: \delta\alpha p_1(T)^2 + \delta\beta p_1(T) c_2(R) + \delta\kappa_{\mathfrak{f}} c_2(F_{\mathfrak{f}}). \end{aligned} \quad (3.1.38)$$

Using the fact that (3.1.31) holds also for free tensor and vector multiplets and

$$\begin{aligned} \delta_0 a &= 24\delta\alpha - 12\delta\beta, \\ \delta_0 c &= 64\delta\alpha - 12\delta\beta, \\ \delta_0 k_{\mathfrak{f}} &= 48\delta\kappa_{\mathfrak{f}}, \end{aligned} \quad (3.1.39)$$

one can completes the proof of $P[N+1]$.

3.1.1.6. Example: $\mathcal{T}_N^{\text{Est}}$

Let us apply the formula (3.1.31) to the case with $\mathcal{T} = \mathcal{T}_N^{\text{Est}}$. Substituting the 6d anomaly polynomial (2.3.9), the 4d central charges are

$$\begin{aligned} a &= \frac{3}{2}N^2 + \frac{5}{2}N - \frac{1}{24}, & c &= \frac{3}{2}N^2 + \frac{15}{4}N - \frac{1}{12}, \\ k_{E_8} &= 12N, & k_{\text{SU}(2)_L} &= 6N^2 - 5N - 1, \end{aligned} \quad (3.1.40)$$

which agree with the result of [65] for the rank N E_8 theory⁹.

3.1.2. ${}^{\text{4d}}\mathcal{T}_0^{(\mathfrak{g},\mathfrak{g})}$ and Class S

In this subsection we will find that the torus compactification of a minimal conformal matter $\mathcal{T}_0^{(\mathfrak{g},\mathfrak{g})}$ ($\mathfrak{g} = A, D, E$) can be identified with a Class S theory by using the brane construction of the conformal matters and string dualities, and do some consistency checks utilizing methods developed in the previous part of this section.

3.1.2.1. String duality to Class S theory

We start from the M-theory realization of $\mathcal{T}_0^{(\mathfrak{g},\mathfrak{g})}$ which is one M5-brane probing the $\mathbb{C}^2/\Gamma_{\mathfrak{g}}$ singularity with trivial discrete C -flux. Compactifying on a torus, going down to the Type IIA and taking T-dual to the Type IIB frame, the 4d theory ${}^{\text{4d}}\mathcal{T}_0^{(\mathfrak{g},\mathfrak{g})}$ can be described by a D3-brane probing the same $\mathbb{C}^2/\Gamma_{\mathfrak{g}}$ singularity in Type IIB on $\mathbb{R}^{1,3} \times \mathbb{R} \times S^1 \times \mathbb{C}^2/\Gamma_{\mathfrak{g}}$. The geometry of the singular locus is $\mathbb{R}^{1,3} \times \mathbb{R} \times S^1$ and it shares the flat 4d space $\mathbb{R}^{1,3}$ with the D3.

Since the position modulus of the D3 is decoupled as the center of mass mode, the D3 probing $\mathbb{C}^2/\Gamma_{\mathfrak{g}}$ should behave as a codimension-2 defect of the $\mathcal{N}=(2,0)$ theory of type \mathfrak{g} , which lives on the singular locus. Regarding two infinities of $R \times S^1$ as full punctures, we predict the 4d theory is a class S theory, namely

$${}^{\text{4d}}\mathcal{T}_0^{(\mathfrak{g},\mathfrak{g})} = \mathbb{T}_{\mathfrak{g}}\{F, X, F\} \quad (3.1.41)$$

where $\mathbb{T}_{\mathfrak{g}}\{\mathcal{O}_1, \mathcal{O}_2, \mathcal{O}_3\}$ means the class S theory with \mathbb{CP}^1 with 3 punctures each labeled by a nilpotent orbit \mathcal{O}_i of \mathfrak{g} , F is the full puncture corresponding to the trivial orbit, and X is a certain puncture coming from the D3. Determining X is the remaining task.

When $\mathfrak{g} = A_{k-1}$, we know $\mathcal{T}_0^{(A_{k-1}, A_{k-1})}$ is a 6d $\mathfrak{su}(k)^{\oplus 2}$ bifundamental hyper, therefore ${}^{\text{4d}}\mathcal{T}_0^{(A_{k-1}, A_{k-1})}$ is the 4d version of that. It is known that $\mathbb{T}_{A_{k-1}}\{F, S, F\}$ with S being the simple puncture corresponding to the subregular (the second largest) orbit $[k-1, 1]$ is the bifundamental hyper, therefore (3.1.41) is true with $\mathfrak{g} = A_{k-1}$, $X = S$. Also, for general $\mathfrak{g} = A, D, E$, we are tempted to conjecture that

$${}^{\text{4d}}\mathcal{T}_0^{(\mathfrak{g},\mathfrak{g})} = \mathbb{T}_{\mathfrak{g}}\{F, S, F\}. \quad (3.1.42)$$

In the following we would like to do some consistency checks listed below:

- the 4d central charges,

⁹The method here is never independent of the method of [65]. This is just a consistency check.

- the dimension of the Coulomb branch, and
- the geometry of the Higgs branch.

In [72], the statement (3.1.42) is verified using an F-theory construction of $\mathcal{T}_N^{(g,g)}$ and the mirror maps.

As a corollary of (3.1.42), since the closing of $g^{\oplus 2}$ flavors in 6d should result in the same closing in 4d, we have

$${}^{4d}\mathcal{T}_0^{(g,g)}\{\mathcal{O}_L, \mathcal{O}_R\} = \mathbb{T}_g\{\mathcal{O}_L, S, \mathcal{O}_R\}. \quad (3.1.43)$$

3.1.2.2. 4d central charges

Using the formulas (2.4.1) and (3.1.31), the 4d central charges of ${}^{4d}\mathcal{T}_0^{(g,g)}$ are

$$a = \frac{1}{24}(1 + 6\chi_{\Gamma_g}|\Gamma_g| - 5d_g), \quad c = \frac{1}{12}(1 + 3\chi_{\Gamma_g}|\Gamma_g| - 2d_g), \quad k_g = 2h_g^\vee, \quad (3.1.44)$$

with $\chi_{\Gamma_g} = 1 + r_g - \frac{1}{|\Gamma_g|}$. To compare, the formula of 4d central charges a, c for $\mathbb{T}_g\{\mathcal{O}_1, \mathcal{O}_2, \mathcal{O}_3\}$ can be found in [73], which are

$$a = -\frac{1}{3}h_g^\vee d_g - \frac{5}{24}r_g + \sum_{i=1,2,3} a(\mathcal{O}_i) \quad (3.1.45)$$

$$c = -\frac{1}{3}h_g^\vee d_g - \frac{1}{6}r_g + \sum_{i=1,2,3} c(\mathcal{O}_i) \quad (3.1.46)$$

with $a(\mathcal{O}_i), c(\mathcal{O}_i)$ being contributions from the puncture \mathcal{O}_i , given by

$$a(F) = \frac{1}{24}(4h_g^\vee d_g - \frac{5}{2}d_g + \frac{5}{2}r_g), \quad a(S) = \frac{1}{24}(6|\Gamma_g|\chi_{\Gamma_g} + 1), \quad (3.1.47)$$

$$c(F) = \frac{1}{12}(2h_g^\vee d_g - d_g + r_g), \quad c(S) = \frac{1}{12}(3|\Gamma_g|\chi_{\Gamma_g} + 1) \quad (3.1.48)$$

for $\mathcal{O} = F, S$. The flavor central charge for the g flavor associated to the full puncture is

$$k_g = 2h_g^\vee. \quad (3.1.49)$$

It is straightforward to check the agreement between the central charges calculated from the description ${}^{4d}\mathcal{T}_0^{(g,g)}$ and from the class S description.

3.1.2.3. Coulomb branch dimension

The 4d Coulomb branch (complex) dimension d of ${}^{4d}\mathcal{T}_0^{(g,g)}$ can be directly calculated from the tensor branch quiver of $\mathcal{T}_0^{(g,g)}$. Instead, it is convenient to further compactify the theory and take the mirror. The 3d theory is identified with the worldvolume theory of an instanton in the 7d SYM theory on $\mathbb{R} \times T^3$ as we have seen in Subsection 2.4.3. The Higgs branch of the 3d mirror theory is thus the g one-instanton moduli on $\mathbb{R} \times T^3$ modulo center of mass mode whose quaternionic

dimension is calculated by the Atiyah-Patodi-Singer index theorem [45] as

$$d = h_{\mathfrak{g}}^{\vee} - r_{\mathfrak{g}} - 1. \quad (3.1.50)$$

Therefore, the complex dimension of the 4d Coulomb branch is equal to this d .

The Coulomb branch dimension formula for the class S theory $\mathbb{T}_{\mathfrak{g}}\{\mathcal{O}_1, \mathcal{O}_2, \mathcal{O}_3\}$ is also in [73], which is

$$d = \sum_{i=1,2,3} \dim d(\mathcal{O}_i) - d_{\mathfrak{g}} \quad (3.1.51)$$

where $d(\mathcal{O}_i)$ is the Spaltenstein dual of \mathcal{O}_i . For $\mathcal{O} = F, S$, we have

$$\dim d(F) = d_{\mathfrak{g}} - r_{\mathfrak{g}}, \quad \dim d(S) = 2(h_{\mathfrak{g}}^{\vee} - 1). \quad (3.1.52)$$

Substituting these, we recover (3.1.50).

3.1.2.4. Higgs branch geometry

As the final check, we match the complex geometry of weakly gauged Higgs branch, which is introduced in 2.4.1, of both side in (3.1.42). The weakly gauged Higgs branch of $\mathcal{F}_0^{(\mathfrak{g}, \mathfrak{g})}$ is $\mathbb{C}^2/\Gamma_{\mathfrak{g}}$ which is manifest from the M-theory brane construction. Thus, our task is to determine the complex geometry of the weakly gauged Higgs branch of $\mathbb{T}_{\mathfrak{g}}\{F, S, F\}$. We have already done that for $\mathfrak{g} = A$ in 2.4.1 when the class S theory is merely hypers. Let $X_{\mathfrak{g}}$ denote the full Higgs branch of $\mathbb{T}_{\mathfrak{g}} = \mathbb{T}\{F, F, F\}$ acted by the flavor groups $G^3 =: G_1 \times G_2 \times G_3$. The Higgs branch $X_{\mathfrak{g}}$ is equipped with three corresponding holomorphic moment maps

$$\mu_{1,2,3} : X_G \rightarrow \mathfrak{g}_{\mathbb{C}}. \quad (3.1.53)$$

The key relation among them is [74, 75]

$$\mathrm{tr}\mu_1^k = \mathrm{tr}\mu_2^k = \mathrm{tr}\mu_3^k \quad (3.1.54)$$

for any positive integer k . Further, the index analysis in [74] shows that all the G_3 invariant Higgs branch operators are generated by μ_1 and μ_2 . Weakly gauging in terms of $G_1 \times G_3$ corresponds to the hyperKähler quotient by the groups, where μ_1, μ_3 are imposed to be zero $\mu_1 = \mu_3 = 0$. This operation forces $\mu_2 \in \mathcal{N}$ where \mathcal{N} is the total nilpotent orbit in $\mathfrak{g}_{\mathbb{C}}$. Therefore, the weakly gauged Higgs branch of $\mathbb{T}_{\mathfrak{g}}$ is the nilpotent orbit \mathcal{N} .

Then we partially close one of F by a nilpotent vev $e \in \mathcal{O}_S$ where \mathcal{O}_S is the subregular orbit corresponding to the puncture S and e should be a generic element of \mathcal{O}_S . e can be represented as $\rho(\sigma^+)$ with some homomorphism $\rho : \mathfrak{su}(2) \rightarrow \mathfrak{g}$ and the ladder operator σ^+ of $\mathfrak{su}(2)$. In the partial closure operation we remove NG hyper modes which are of the form $[e, x]$ with some $x \in \mathfrak{g}_{\mathbb{C}}$. The remaining modes of the image of the moment map μ_2 is

$$S_e := \{x + e \mid [x, \rho(\sigma^-)] = 0\} \quad (3.1.55)$$

which is called the Slodowy slice. Therefore, the weakly gauged Higgs branch of $\mathbb{T}_{\mathfrak{g}}\{F, S, F\}$ is

$S_e \cap \mathcal{N}$. Then the theorem in [76, 77] concludes

$$S_e \cap \mathcal{N} = \mathbb{C}^2 / \Gamma_{\mathfrak{g}} \quad (3.1.56)$$

as a complex geometry when e is a generic element of \mathcal{O}_S , which is what we wanted to prove.

3.2. Compactification of theories higgsable to $\mathcal{T}_N^{\text{Est}}$

In this section, which is devoted to explain the paper [15], we investigate circle/torus compactification of a class of 6d SCFTs $\mathcal{T}^{(\text{M9}, \text{su})}\{u_i\}$, $\mathcal{T}_*^{(\text{M9}, \text{su})}\{u_i\}$ introduced in Subsection 2.5.2 whose tensor branch quivers are

$$[\mathfrak{f}_1] \quad \emptyset \quad \mathfrak{su}(u_2) \quad \mathfrak{su}(u_3) \quad \cdots \quad \mathfrak{su}(u_N) \\ \quad \quad \quad 1 \quad \quad 2 \quad \quad 2 \quad \quad \cdots \quad \quad 2 \quad \quad . \quad (3.2.1)$$

u_2 should be no more than 8 for $\mathcal{T}^{(\text{M9}, \text{su})}\{u_i\}$ and no more than 9 for $\mathcal{T}_*^{(\text{M9}, \text{su})}\{u_i\}$, and the flavor \mathfrak{f}_1 is \mathfrak{e}_{9-u_2} for $\mathcal{T}^{(\text{M9}, \text{su})}\{u_i\}$ and $\tilde{\mathfrak{e}}_{9-u_2}$ for $\mathcal{T}_*^{(\text{M9}, \text{su})}\{u_i\}$. For other theories which is higgsable to E-string theories with \mathfrak{su} gauge groups briefly examined in the last part of Subsection 2.5.2, basically the same method is applied in [78].¹⁰

Our main claim here for the S^1/T^2 compactification ${}^{5d}\mathcal{T}^{(\text{M9}, \text{su})}\{u_i\}$, ${}^{4d}\mathcal{T}^{(\text{M9}, \text{su})}\{u_i\}$ is

$${}^{5d}\mathcal{T}^{(\text{M9}, \text{su})}\{u_i\} = \widehat{\mathbb{T}}_K\{Y_1, Y_2, Y_3\}, \quad (3.2.2)$$

where $\widehat{\mathbb{T}}_K\{Y_1, Y_2, Y_3\}$ is the 5d uplifting of the 4d Class S theory $\mathbb{T}_K\{Y_1, Y_2, Y_3\}$ of type A_{K-1} , whose UV curve is the sphere with three punctures Y_1 , Y_2 , and Y_3 .

K denotes $6N + n_7 + n_8$, where $n_I = \#\{i = 2, 3, \dots, N \mid u_{i+1} - u_i \geq I\}$. Y_2 and Y_3 are the partitions of K defined by $Y_2 = [2N + n_7 + n_8, 2N, 2N]$ and $Y_3 = [3N + n_7, 3N + n_8]$. Let $Y_1^T = [\ell_1, \dots, \ell_N]$ be the partition of K obtained by taking the transpose of the Young diagram Y_1 , then

$$\begin{cases} \ell_i = 0 & (i \geq N - n_6 + 1) \\ \ell_{N-i+2} = 6 - u_i + u_{i-1} & (i = 2, \dots, N - n_6) \\ \ell_1 = 6 + u_N. \end{cases} \quad (3.2.3)$$

The 4d version of the statement

$${}^{4d}\mathcal{T}^{(\text{M9}, \text{su})}\{u_i\} = \mathbb{T}_K\{Y_1, Y_2, Y_3\} \quad (3.2.4)$$

automatically follows.

When $u_i = 0$ for all $i = 2, \dots, N$, $\mathcal{T}^{6d}\{u_i = 0\}$ is the rank N E-string theory, and the corresponding class S theory is $\widehat{\mathbb{T}}_{6N}\{[N^6], [2N, 2N, 2N], [3N, 3N]\}$ which is proposed in [18] as the S^1 compact-

¹⁰The paper [78] coincidentally appeared on arXiv with [15]. The basic strategy is almost the same, and the former covers more general cases than the latter.

ification of the rank N E-string theory.¹¹ Thus, our claim generalizes the result of them. For the compactifications of $\mathcal{T}_*^{6d}\{u_i\}$, the claim is

$${}^{5d}\mathcal{T}_*^{(M9, su)}\{u_i\} = \widehat{T}_{K_*}\{Y_1, Y_2^*, Y_3^*\}, \quad (3.2.5)$$

$${}^{4d}\mathcal{T}_*^{(M9, su)}\{u_i\} = T_{K_*}\{Y_1, Y_2^*, Y_3^*\}, \quad (3.2.6)$$

where $K_* = 6N + n_7 + n_8 + n_9$, $Y_2^* = [2N + n_7, 2N + n_8, 2N + n_9]$, and $Y_3^* = [3N + n_7 + n_8 + n_9, 3N]$. Y_1 is defined by the same equations as the former case. When $u_2 \leq 7$, $K_* = K$, $Y_2^* = Y_2$ and $Y_3^* = Y_3$ holds.

Note that a single 4d SCFT might admit multiple class S constructions, and thus the above class S descriptions are not necessarily unique.

In Subsection 3.2.1.3, by T-dualizing the Type I' brane construction, we will find the 5-brane web describing the 5d SCFT obtained by the S^1 compactification. The resulting web has three external legs of 5-branes terminated at 7-branes [18], and from the webs we will show the results (3.2.2) and (3.2.5). Then, it follows that the T^2 compactification is given by the A-type 6d $\mathcal{N}=(2, 0)$ theory on a sphere with three punctures, confirming (3.2.4) and (3.2.6).

In section 3.2.2.2, we will provide further evidence for the 4d version of our main claims (3.2.4) and (3.2.6) by calculating 4d conformal and flavor central charges in two ways. First the charges are obtained from the 6d tensor branch structure and the formula (3.1.31) we derived, and then we get the same quantities from the corresponding class S description by using the methods developed in [73, 80]

3.2.1. IIB web diagrams

In this section, we establish the dualities (3.2.2), (3.2.4), (3.2.5) and (3.2.6). First of all, we briefly recall a class of 5d SCFTs introduced in [18] as 5d uplifts of some class S theories. Each of them is engineered by a junction of 5-branes with three legs which consist of K 5-branes with charges $(1, 0)$, $(0, 1)$ and $(1, -1)$ respectively, as illustrated in Figure 3.2. They are terminated at 7-branes of type $(1, 0)$, $(0, 1)$ and $(1, -1)$, respectively. The ending pattern of the 5-branes at the 7-branes specifies a partition of K and then we associate a Young diagram Y_i ($i = 1, 2, 3$) for each leg.

When we shrink the internal part of the web to a single point, we obtain the 5d SCFT $\widehat{T}_K\{Y_1, Y_2, Y_3\}$, the right hand side of (3.2.2). Upon further reduction to 4d, this 5d theory becomes the class S theory $T_K\{Y_1, Y_2, Y_3\}$ in (3.2.4).

To connect this 5-brane web construction of the 5d SCFT $\widehat{T}_K\{Y_1, Y_2, Y_3\}$ with the Type I' brane engineering in Section 2.5, we utilize T-duality and Hanany-Witten effect. This proceeds as follows. First, we T-dualize the Type I' brane configuration in Sec 2.5 to obtain the Type IIB brane configuration with 5-branes and 7-branes, which corresponds to the S^1 compactification of $\mathcal{T}_{(*)}^{(M9, su)}\{u_i\}$. Second, by taking a mass decoupling limit, we find the web configuration which

¹¹ When $u_i = 1$ for $i = 2, \dots, N$, $\mathcal{T}^{6d}\{u_i = 1\}$ is the rank N E-string theory plus a decoupled hyper, and the corresponding theory is $\widehat{T}_{6N}\{[N^5, N-1, 1], [2N, 2N, 2N], [3N, 3N]\}$, which was firstly observed by the index calculation [79].

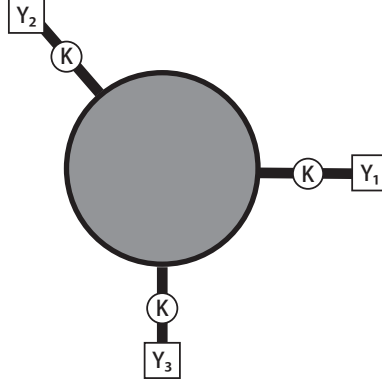

Figure 3.2.: The 5-brane web configuration introduced in [18]. It has three legs made up of K 5-branes of type $(1, 0)$, $(0, 1)$ and $(1, -1)$ respectively. The 5-branes in each leg terminate on 7-branes of the same type. The ending pattern of each leg at the 7-branes determines the Young diagram Y_i . Since the internal 5-brane web configuration is determined (up to flop transitions) by the boundary data K and Y_i ($i = 1, 2, 3$), we do not write it explicitly. The 5d SCFT from this web is the 5d uplift $\widehat{\mathbb{T}}_K\{Y_1, Y_2, Y_3\}$ of the class S theory $\mathbb{T}_K\{Y_1, Y_2, Y_3\}$.

describes the 5d SCFT ${}^{5d}\mathcal{T}_{(*)}^{(M9, su)}\{u_i\}$ obtained by the zero radius limit $R_6 \rightarrow 0$. This mass deformation is achieved by moving one 7-brane toward the infinity without creating 5-branes due to Hanany-Witten effect.

Finally, we move the remaining 7-branes toward the infinity. During the process, Hanany-Witten effect creates additional 5-branes. We find that the resulting 5-brane web configuration is that of Figure 3.2, a three pronged junction of 5-branes terminated at 7-branes. Thus, we establish the results (3.2.2), (3.2.4), (3.2.5) and (3.2.6). In the rest of this section, we explain the strategy outlined above more concretely.

3.2.1.1. Notations on 7-branes

Before moving to the concrete process, we summarize notations and conventions we use in the rest of this section about 7-branes in Type IIB [17, 18, 81–83]. Let $\mathbf{X}_{[P, Q]}$ denotes the 7-brane with charge $[P, Q]$ where P, Q are coprime. We use the following aliases $\mathbf{A} = \mathbf{X}_{[1, 0]}$, $\mathbf{B} = \mathbf{X}_{[1, -1]}$, $\mathbf{C} = \mathbf{X}_{[1, 1]}$, and $\mathbf{N} = \mathbf{X}_{[0, 1]}$. The monodromy matrix $K(\mathbf{X}_{[P, Q]}) = K_{[P, Q]}$ of the 7-brane $\mathbf{X}_{[P, Q]}$ is

$$K_{[P, Q]} = \begin{pmatrix} 1 + PQ & -P^2 \\ Q^2 & 1 - PQ \end{pmatrix}. \quad (3.2.7)$$

A 5-brane with charge (p, q) , when anti-clockwise crossing the branch cut of the 7-brane $\mathbf{X}_{[P, Q]}$, becomes a (p', q') 5-brane where

$$\begin{pmatrix} p' \\ q' \end{pmatrix} = K_{[P, Q]} \begin{pmatrix} p \\ q \end{pmatrix} = \begin{pmatrix} p \\ q \end{pmatrix} - (Pq - Qp) \begin{pmatrix} P \\ Q \end{pmatrix}. \quad (3.2.8)$$

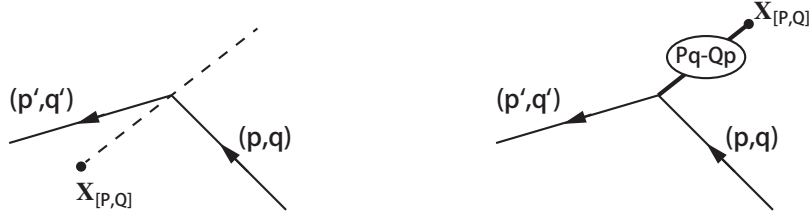

Figure 3.3.: The Hanany-Witten effect between a 7-brane and a 5-brane.

When a 7-brane $\mathbf{X}_{[P,Q]}$ crosses a (p, q) 5-brane as in the Figure 3.3, the Hanany-Witten effect attaches (P, Q) 5-branes to the 7-brane. The number of the emergent (P, Q) 5-branes should be $|Pq - Qp|$ so that the tension balances at the trivalent point.

When there are some 7-branes $\mathbf{X}_{[P_1, Q_1]}, \mathbf{X}_{[P_2, Q_2]}, \dots, \mathbf{X}_{[P_n, Q_n]}$ arranged anti-clockwise in this ordering, we denote the configuration by just writing them as

$$\mathbf{X}_{[P_1, Q_1]} \mathbf{X}_{[P_2, Q_2]} \cdots \mathbf{X}_{[P_n, Q_n]}, \quad (3.2.9)$$

and the corresponding monodromy matrix as

$$K(\mathbf{X}_{[P_1, Q_1]} \mathbf{X}_{[P_2, Q_2]} \cdots \mathbf{X}_{[P_n, Q_n]}) = K_{[P_n, Q_n]} K_{[P_{n-1}, Q_{n-1}]} \cdots K_{[P_1, Q_1]}. \quad (3.2.10)$$

We can rearrange two 7-branes $\mathbf{X}_{[P_1, Q_1]}, \mathbf{X}_{[P_2, Q_2]}$ by the following rule:

$$\mathbf{X}_{[P_1, Q_1]} \mathbf{X}_{[P_2, Q_2]} = \mathbf{X}_{[P_2, Q_2]} \mathbf{X}_{[P'_1, Q'_1]} = \mathbf{X}_{[P'_2, Q'_2]} \mathbf{X}_{[P_1, Q_1]}, \quad (3.2.11)$$

where

$$\begin{pmatrix} P'_1 \\ Q'_1 \end{pmatrix} = K_{[P_2, Q_2]} \begin{pmatrix} P_1 \\ Q_1 \end{pmatrix}, \quad \begin{pmatrix} P'_2 \\ Q'_2 \end{pmatrix} = K_{[P_1, Q_1]} \begin{pmatrix} P_2 \\ Q_2 \end{pmatrix}. \quad (3.2.12)$$

We name some important 7-brane configurations such as

$$\mathbf{E}_N = \mathbf{A}^{N-1} \mathbf{BCC} = \mathbf{A}^N \mathbf{X}_{[3, -1]} \mathbf{N}, \quad (3.2.13)$$

$$\widehat{\mathbf{E}}_N = \mathbf{E}_N \mathbf{X}_{[3, 1]} = \mathbf{A}^{N-1} \mathbf{BCBC} = \mathbf{A}^N \mathbf{BX}_{[1, 2]} \mathbf{X}_{[2, 1]}. \quad (3.2.14)$$

Here we assume that $N \geq 2$. When $N = 1$, we cannot equate $\mathbf{E}_1 = \mathbf{BCC}$ to $\mathbf{AX}_{[3, -1]} \mathbf{N}$ by the operations (3.2.11); therefore, the latter is an inequivalent configuration which is denoted as $\tilde{\mathbf{E}}_1$. We define \mathbf{E}_0 by $\mathbf{X}_{[3, -1]} \mathbf{N}$. The configuration $\widehat{\mathbf{E}}_1$ and $\widehat{\mathbf{E}}_0$ is again given by $\tilde{\mathbf{E}}_1 \mathbf{X}_{[3, 1]}$ and $\mathbf{E}_0 \mathbf{X}_{[3, 1]}$ respectively.

3.2.1.2. Warm up: T-dual of E-string theory

To begin with, we start from the case where all the gauge algebras are empty in (3.2.1), where the 6d theory is now the rank- N E-string theory. While the result of this section was first obtained in [18], we adopt the T-duality argument from [84].

We start from the Type I' brane configuration where we have seven D8 branes on top of the

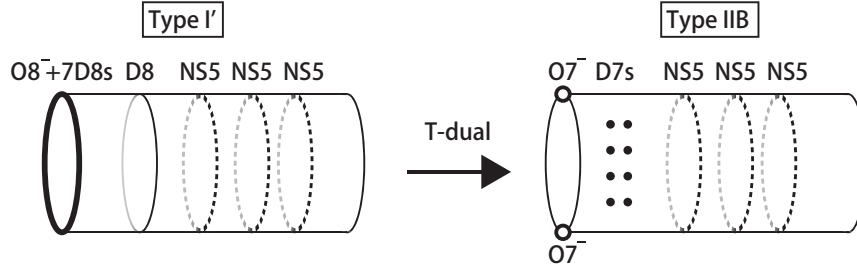

Figure 3.4.: T-dual of the Type I' brane configuration realizing S^1 compactified higher rank E-string theory. The $O8^-$ plane wrapping S^1 becomes two $O7^-$ planes and the eight D8s become eight D7 branes, while the NS5 branes in type I' remain to be NS5.

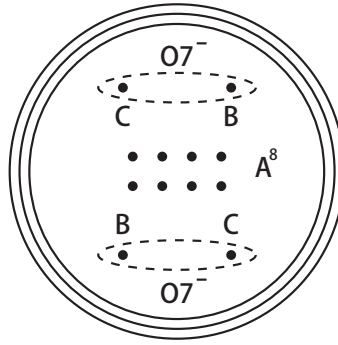

Figure 3.5.: The Type IIB brane configuration in Figure 3.4 seen from the left. The $O7^-$ planes splits into **B** and **C** branes, therefore there are twelve 7-branes wrapped by the N circles of 5-branes.

$O8^-$ plane and one D8 brane slightly away from the $O8^-$ plane. There are also N NS5 branes away from that $O8^-$ -D8 system where the Romans mass is 0.

After the S^1 compactification, we can take the T-dual of the brane system to obtain the Type IIB $O7^-$ -D7-NS5 system, as illustrated in Figure 3.4. Note that this T-dual is valid because in the Type I' configuration, the Romans mass is 0 far from the $O8^-$ plane, and thus the dual Type IIB geometry should asymptotically be the cylinder.

Since the $O7^-$ plane is the bound state of two 7-branes of type **B** and **C** [85] and the D7 brane is of type **A**, the system is equivalent to N 5-branes encircling twelve 7-branes $\widehat{\mathbf{E}}_9 = \mathbf{A}^8 \mathbf{B} \mathbf{C} \mathbf{B} \mathbf{C}$ as shown in Figure 3.5, which is considered in [86]. Note that since each 7-brane has deficit angle $\frac{1}{6}\pi$, the total deficit angle of twelve 7-branes is 2π , and therefore the metric of the diagram Figure 3.5 is that of the cylinder outside of where 7 branes sit. The same fact is also related to the fact $K(\widehat{\mathbf{E}}_9) = 1$.

Mass decoupling of Kaluza-Klein modes. The configuration in Figure 3.5 engineers the theory with Kaluza-Klein modes [86]. To obtain the 5d SCFT with $\epsilon_8 \times su(2)$ global symmetry from the E-string theory on S^1 , we need to decouple the Kaluza-Klein modes by taking $R^6 \rightarrow 0$ preserving the global symmetry.

This can be achieved by rearranging the 7-branes by $\mathbf{BCBC} = \mathbf{BCCX}_{[3,1]}$ and moving $\mathbf{X}_{[3,1]}$ toward the infinity, leaving the \mathbf{E}_9 7-brane inside the circles of 5-branes. Here we show that we can make this decoupling without introducing additional 5-branes coming from the Hanany-Witten effect.

To this end, we note that each 7-brane inside the circle has a branch cut that runs toward the infinity. When the circle of 5-brane crosses the cut, the (p, q) charge of the 5-brane which makes up the circle changes to (p', q') according to the formula (3.2.12). The fact $K(\widehat{\mathbf{E}}_9) = 1$ ensures that the charge of the 5-brane comes back to its original value after crossing all the cuts from the 7-branes, as required by the consistency. We can choose the charge at a small segment in the circle to be $(3, 1)$. Then, we can move the 7-brane $\mathbf{X}_{[3,1]}$ to the infinity through that segment without Hanany-Witten effect.

Pulling out 7-branes. In order to obtain the 5-brane web as in Figure 3.2, we rearrange the 7-branes and pull them out from the circles. We rearrange the five 7-branes $\mathbf{E}_3 = \mathbf{A}^2\mathbf{BCC}$ in the remaining 7-branes \mathbf{E}_9 inside the circles as

$$\mathbf{E}_3 = \mathbf{A}^2\mathbf{BCC} = \mathbf{BN}^2\mathbf{C}^2 = \mathbf{BNA}^2\mathbf{N} = \mathbf{B}^3\mathbf{N}^2, \quad (3.2.15)$$

where we used $\mathbf{AB} = \mathbf{BN}, \mathbf{NC} = \mathbf{AN}$ and $\mathbf{NA} = \mathbf{BN}$. Note that this rearrangement is nothing but moving two \mathbf{A} branes from the leftmost to the rightmost in \mathbf{E}_3 .

Then, we move the three types of 7-branes \mathbf{A} , \mathbf{B} and \mathbf{N} toward the infinity. To count the number of additional 5-branes created by Hanany-Witten effect, we concretely keep track of the charges of the circle of 5-brane. When decoupling the 7-brane $\mathbf{X}_{[3,1]}$, we take the charge in the segment of the circle to be $(3, 1)$. Then, using (3.2.12) the change of the charge is given as

$$\begin{aligned} (3, 1) \xrightarrow{\mathbf{A}} (2, 1) \xrightarrow{\mathbf{A}} \cdots \xrightarrow{\mathbf{A}} (-3, 1) \xrightarrow{\mathbf{B}} (-1, -1) \xrightarrow{\mathbf{B}} (1, -3) \\ \xrightarrow{\mathbf{B}} (3, -5) \xrightarrow{\mathbf{N}} (3, -2) \xrightarrow{\mathbf{N}} (3, 1), \end{aligned} \quad (3.2.16)$$

where the symbols on top of the arrows represents the fact that 5-brane crosses the cut emanating from the 7-brane of the corresponding type. The 5-brane charge goes back to the initial value $(3, 1)$, as already mentioned.

Then, we pull out the 7-branes from the inside of the circle along the cut. The formula (3.2.8) and the change in the 5-brane charge (3.2.16) give the number of 5-branes created by Hanany-Witten effect when the 7-brane crosses the circle of 5-brane. We have one extra $(1, 0)$ 5-brane attached to \mathbf{A} , extra two $(1, -1)$ 5-branes attached to \mathbf{B} , and extra three $(0, 1)$ 5-branes attached to \mathbf{N} respectively after crossing a circle of 5-brane.

Finally, we have a three-pronged junction of 5-branes where each legs have $6N$ 5-branes terminated at 7-branes as shown in Fig 3.6. The patterns of terminations correspond to the Young diagrams $Y_1 = [N^6]$, $Y_2 = [2N, 2N, 2N]$ and $Y_3 = [3N, 3N]$. For example, N $(1, 0)$ 5-branes are grouped into a bunch and are terminated at a single \mathbf{A} .

This 5-brane web describes the 5d theory $\widehat{\mathcal{T}}_K\{Y_1, Y_2, Y_3\}$ [18]. Thus, we have shown using T-duality and Hanany-Witten effect that the S^1 compactification of rank- N E-string theory is the 5d uplift of the class S theory.

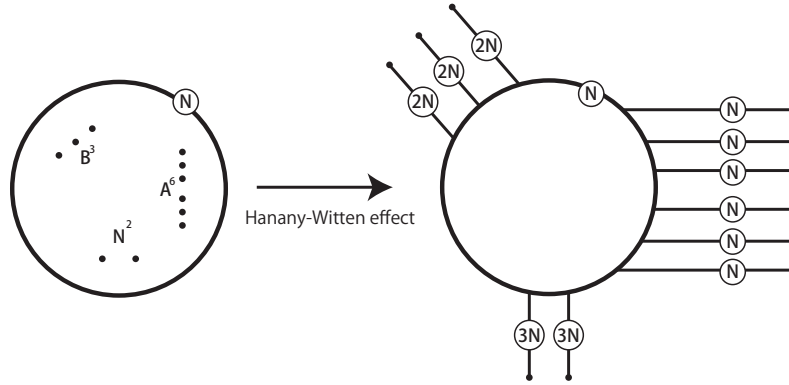

Figure 3.6.: Pulling out eleven 7-branes $\mathbf{A}^6\mathbf{B}^3\mathbf{N}^2$ from the inside of the N circles of 5-brane creates the 5-brane junction with three legs due to Hanany-Witten effect. Each leg consists of $6N$ 5-branes. These 5-branes are grouped as shown in the right hand side of the figure and each group is terminated at a 7-brane.

3.2.1.3. T-dual of 6d theory $\mathcal{T}_{(*)}^{(M9,su)}\{u_i\}$

Next we would like to generalize the result of Sec 3.2.1.2 to $\mathcal{T}^{(M9,su)}\{u_i\}$. To this end, we take T-dual of the Type I' brane configuration we studied in Subsection 2.5.2. Before taking T-dual, it is (just technically) convenient to cause Hanany Witten transitions as depicted in Figure 3.7. Then, after taking T-dual, the resulting Type IIB configuration is illustrated in Figure 3.8. We note that the case considered in Sec 3.2.1.2 corresponds to $n_7 = n_8 = 0$ and $Y_1 = [N^6]$.

The $O8^-$ plane and two D8 branes at $x^6 = 0$ become six 7-branes $\widehat{\mathbf{E}}_3 = \mathbf{A}^2\mathbf{BCBC}$. The NS5 branes become the N circles of 5-branes wrapping the six 7-branes $\widehat{\mathbf{E}}_3 = \mathbf{A}^2\mathbf{BCBC}$. We also have D6 branes in the Type I' configuration, which become extra $(1,0)$ 5-branes in the Type IIB setup. n_7 and n_8 $(1,0)$ 5-branes are attached to two \mathbf{A} 7-branes wrapped by the N circles of 5-branes respectively. These extra 5-branes extend toward the infinity and we have $6N + n_7 + n_8$ 5-branes out of the circles due to Hanany-Witten effect. They are terminated at \mathbf{A} type 7-branes, which come from $6 + u_N$ D8 branes sitting where x^6 is very large in the Type I' configuration. The ending pattern is specified by the Young diagram Y_1 in (3.2.3).

The setup in Figure 3.8 includes the Kaluza-Klein modes. The decoupling of these modes can be done as in Sec 3.2.1.2 by rewriting $\widehat{\mathbf{E}}_3 = \mathbf{E}_3\mathbf{X}_{[3,1]}$ and moving $\mathbf{X}_{[3,1]}$ toward the infinity. Again, no additional 5-branes are created during the decoupling and we have five 7-branes $\mathbf{E}_3 = \mathbf{A}^2\mathbf{BCC}$ inside the circles.

Pulling out 7-branes. In order to obtain the 5-brane web as in Figure 3.2, we rearrange the 7-branes inside the circles and pull them out toward the infinity. The rearrangement can be done by moving the 7-branes as in (3.2.15). We carefully keep track the effect from the extra n_7 and n_8 $(1,0)$ 5-branes attached to the two \mathbf{A} type 7-branes in Figure 3.9. After the rearrangement, one of the three \mathbf{B} s has new $n_7 + n_8$ 5-branes and the two \mathbf{N} s have new n_7 and n_8 5-branes attached to it respectively.

Then, we pull all the 7-branes out of the circles. As in Sec 3.2.1.2, we have one extra $(1,0)$

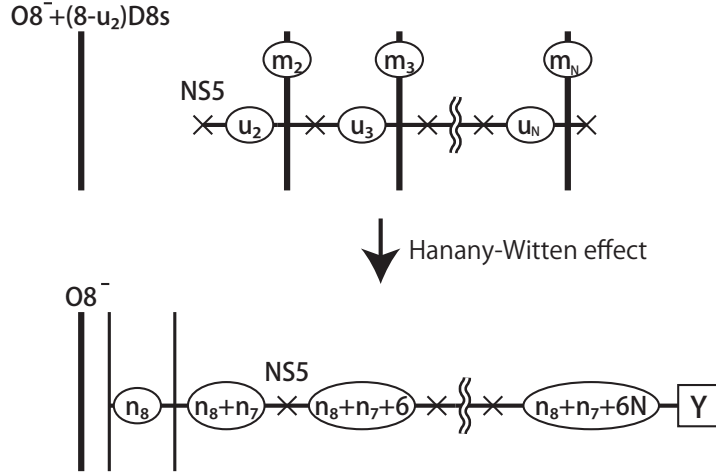

Figure 3.7.: Upper: The same as Figure 2.12. Lower: Type I' configuration after the pre-processing Hanany-Witten transitions. There are two D8 branes near the $O8^-$ plane, each has n_7 and n_8 D6 branes ending on it, and $u_N + 6$ D8 branes on the right side of the N th NS5 brane. The $K = n_8 + n_7 + 6N$ D6 branes end on the stack of $u_N + 6$ D8 branes, and the pattern of the ending is specified by the Young diagram Y_1 (3.2.3) [53].

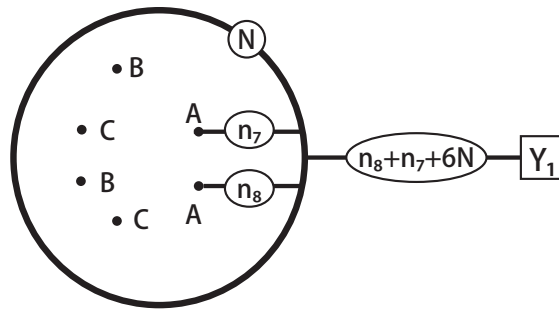

Figure 3.8.: The Type IIB web for the 6d theory $\mathcal{T}^{(M9, su)}\{u_i\}$ on S^1 with Kaluza-Klein modes. We have N circles of 5-branes. Outside the circles, we have a leg of $6N + n_7 + n_8$ 5-branes terminated at 7-branes as specified by the partition Y_1 . Inside the circle, we have six 7-branes A^2BCBC . n_7 and n_8 5-branes are attached to the two A 7-branes respectively.

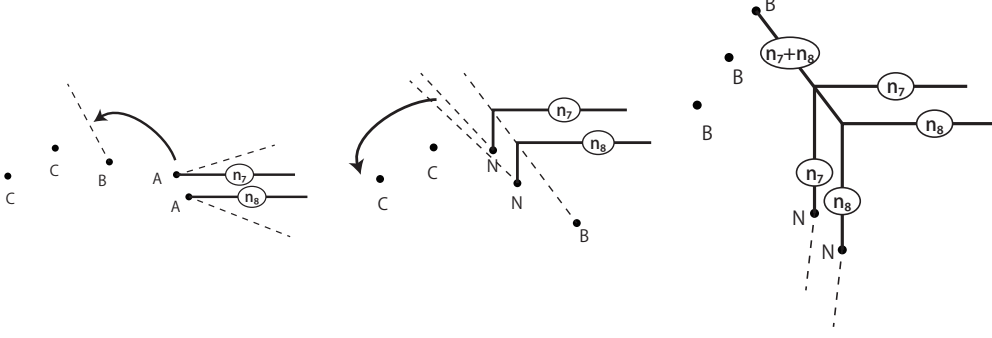

Figure 3.9.: The 7-brane rearrangement inside the circle of 5-branes. Extra n_7 and n_8 5-branes attached to two **A** create the junction of 5-branes due to the Hanany-Witten effect. First, we move two **A** across the cut of **B**. **A** becomes **N** and we obtain the middle configuration. Second, we move two **C**s through the branch cuts of **N**s. After that process, \mathbf{C}^2 becomes \mathbf{B}^2 since they cross the cuts from two **N**. Finally, by moving one **B** along its cut, we obtain the configuration in right.

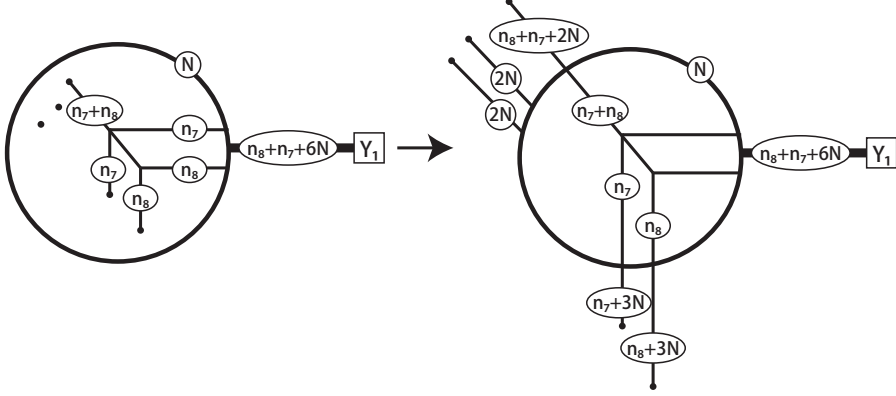

Figure 3.10.: Pulling the eleven 7-branes from the inside of the circles of 5-branes, we again obtain the junction of 5-branes with three external legs.

5-brane attached to **A**, extra two $(1, -1)$ 5-branes attached to **B**, and extra three $(0, 1)$ 5-branes attached to **N** respectively after crossing a circle of 5-brane. The result is shown in Figure 3.10. We again have a three-pronged junction of 5-branes where each leg has $K = 6N + n_7 + n_8$ 5-branes terminated at 7-branes. The patterns of terminations are given by the Young diagrams Y_1 , $Y_2 = [2N + n_7 + n_8, 2N, 2N]$ and $Y_3 = [3N + n_7, 3N + n_8]$.

This is the 5-brane web which describes the 5d uplift $\widehat{T}_K\{Y_1, Y_2, Y_3\}$ of the class S theory $T_K\{Y_1, Y_2, Y_3\}$. Thus we have shown (3.2.2) using T-duality and Hanany-Witten effect.

Case with $O8^*$ plane. Next we consider the S^1 compactification of the 6d theory $\mathcal{T}_*^{(M9, su)}\{u_i\}$ whose Type I' brane engineering uses the $O8^*$ plane. To begin with, let us consider the T-dual of the $O8^*$ plane. As in Eq. (2.5.13), the $O8^*$ can be obtained by pulling two D8 branes from $O8^-+D8$. Noting that the T-dual of $O8^-+D8$ is \widehat{E}_2 , the operation corresponding to $(O8^-+D8 \rightarrow$

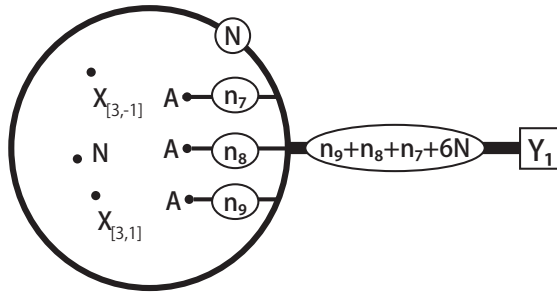

Figure 3.11.: The Type IIB web for the 6d theory $\mathcal{T}_*^{(M9, su)}\{u_i\}$ on S^1 with Kaluza-Klein modes. We have N circles of 5-brane. Outside the circles, we have a leg of $6N + n_7 + n_8 + n_9$ 5-branes terminated at 7-branes. Inside the circles, we have six 7-branes $A^3 X_{[3,-1]} N X_{[3,1]}$. n_7 , n_8 and n_9 5-branes are attached to three A 7-branes respectively.

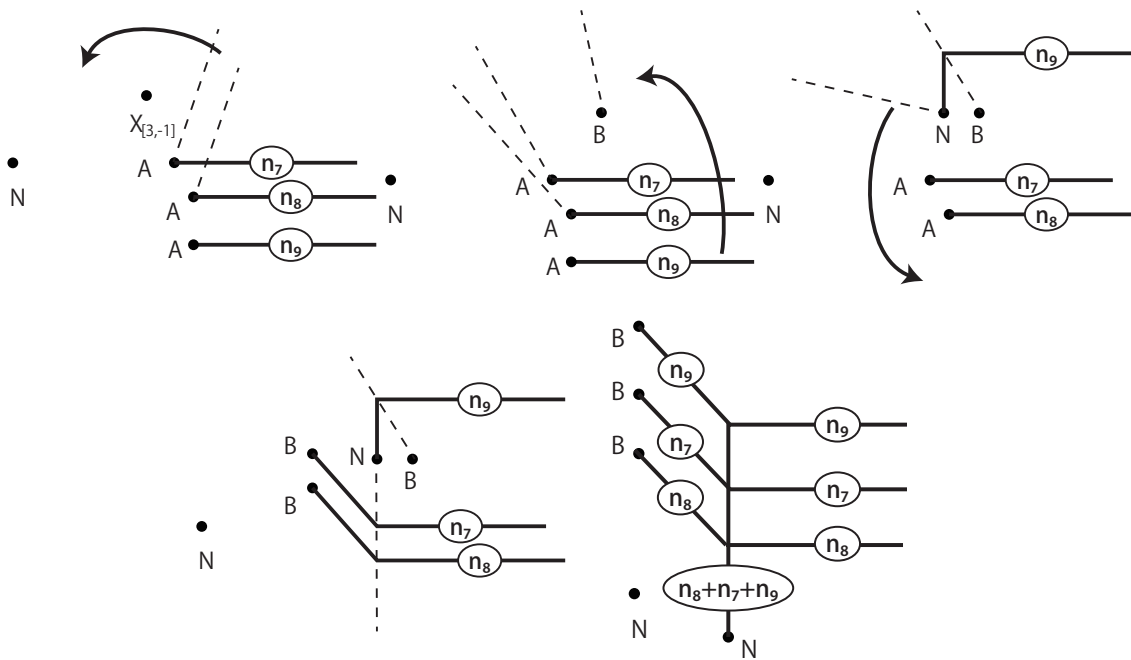

Figure 3.12.: The 7-brane rearrangement inside the circle of 5-branes. Extra 5-branes attached to the three A branes create the junction of 5-branes due to the Hanany-Witten effect.

O8*, 2D8) in the Type IIB frame should be

$$\widehat{\mathbf{E}}_2 = \mathbf{A}\widehat{\mathbf{E}}_1 = \mathbf{A}^2\widehat{\mathbf{E}}_0. \quad (3.2.17)$$

Therefore, we conclude that the T-dual of the O8* plane is $\widehat{\mathbf{E}}_0$.

It is now straightforward to take T-dual of the 6d theory $\mathcal{T}_*^{(M9, su)}\{u_i\}$. The configuration is illustrated in Fig 3.11. There are N circles of 5-brane and there is a leg of $6N + n_7 + n_8 + n_9$ 5-branes outside the circles. The six 7-branes inside the circles are now $\mathbf{A}^3\widehat{\mathbf{E}}_0$ where $\widehat{\mathbf{E}}_0 = \mathbf{X}_{[3,-1]}\mathbf{N}\mathbf{X}_{[3,1]}$.

The decoupling of Kaluza-Klein modes can be done by moving $\mathbf{X}_{[3,1]}$ toward the infinity. Again, no additional 5-branes are created during the decoupling and we have $\mathbf{A}\mathbf{A}\mathbf{A}\mathbf{E}_0$ where $\mathbf{E}_0 = \mathbf{X}_{[3,-1]}\mathbf{N}$ inside the circles.

In order to obtain the 5-brane web as in Figure 3.2, we rearrange the 7-branes and pull them out from the circles. The required rearrangement is given as

$$\mathbf{A}\mathbf{A}^2\mathbf{X}_{[3,-1]}\mathbf{N} = \mathbf{A}\mathbf{B}\mathbf{A}^2\mathbf{N} = \mathbf{B}\mathbf{N}\mathbf{A}^2\mathbf{N} = \mathbf{B}^3\mathbf{N}^2. \quad (3.2.18)$$

Taking account for the fact that there are extra $n_{7,8,9}$ 5-branes attached to the three \mathbf{A} s in Eq. (3.2.18), the brane rearrangement is illustrated in Fig 3.12.

By pulling all the 7-branes out of the circles, we again have a three-pronged junction of 5-branes where each leg has $K_* = 6N + n_7 + n_8 + n_9$ 5-branes. Now we have three Young diagrams Y_1 , $Y_2^* = [2N + n_7, 2N + n_8, 2N + n_9]$ and $Y_3^* = [3N + n_7 + n_8 + n_9, 3N]$. Therefore, we have shown the result (3.2.5).

3.2.2. 4d conformal anomalies

In this section we compute the conformal and flavor central charges for the 4d theories $\mathcal{T}^{4d}\{u_i\}$ and $\mathbb{T}_K\{Y_1, Y_2, Y_3\}$, and find the agreement. This provides another evidence for our claims (3.2.4) and (3.2.6).

In this section we assume $u_i \geq 1$ for $i = 2, \dots, N$. Otherwise, the 6d theory is the higher rank E-string theory and the agreement of the central charges was already checked in [14, 18].

3.2.2.1. Central charges of $\mathcal{T}_{(*)}^{4d}\{u_i\}$ from 6d anomaly polynomial

The conformal anomalies a , c and the flavor central charge k_i for the flavor symmetry \mathfrak{f}_i were calculated in [14] for the 4d $\mathcal{N}=2$ theory $\mathcal{T}^{4d}\{u_i\}$. They are given as

$$a = 24\alpha - 12\beta - 18\gamma, \quad c = 64\alpha - 12\beta - 8\gamma, \quad k_i = 48\sigma_i, \quad (3.2.19)$$

where α, β, γ and σ_i are the coefficients of the anomaly polynomial 8-form I^{6d} of the 6d theory $\mathcal{T}^{6d}\{u_i\}$, defined by¹²

$$I^{6d} \supset \alpha p_1(T)^2 + \beta p_1(T)c_2(F_R) + \gamma p_2(T) + \sum_i \sigma_i p_1(T)c_2(F_i). \quad (3.2.20)$$

¹²Our normalizations for central charges and anomaly polynomial are those of [14, 16]

Here, $p_i(T)$ is the i th Pontryagin class of the tangent bundle and $c_2(F) = \frac{1}{4}\text{Tr}F^2$ is the second Chern class of the R - or flavor symmetry bundle, where F_i is the background field strength for the global symmetry \mathfrak{f}_i . It is convenient to define the effective numbers n_v and n_h of vector and hypermultiplets by

$$n_v = 8a - 4c = -16(4\alpha + 3\beta + 7\gamma), \quad n_h = 20c - 16a = 16(56\alpha - 3\beta + 8\gamma). \quad (3.2.21)$$

The algorithm for computing I^{6d} was provided in [4]. The anomaly polynomial I^{6d} splits into two parts as

$$I^{6d} = I^{\text{one-loop}} + I^{\text{GS}}, \quad (3.2.22)$$

where $I^{\text{one-loop}}$ is the naive one-loop contribution from the massless matter contents at a generic point on the tensor branch. I^{GS} is the contribution from the 6d Green-Schwarz term given by

$$I^{\text{GS}} = \frac{1}{2}\eta^{ij}I_iI_j, \quad (3.2.23)$$

where I_i are 4-forms topologically coupled to the self-dual two forms B_i by the action

$$\eta^{ij} \int B_i I_j. \quad (3.2.24)$$

Here η^{ij} is the kinetic matrix in the effective Lagrangian for the tensor multiplet scalars a_i and the gauge field strengths $F_{\mathfrak{g}_i}$;

$$2\pi \int \eta^{ij} \left(\frac{1}{4} a_i \text{Tr} F_j \wedge \star F_j - \frac{1}{2} da_i \wedge \star da_j \right). \quad (3.2.25)$$

For our case, η^{ij} is determined to be

$$\eta^{ij} = \begin{pmatrix} 1 & -1 & & & \\ -1 & 2 & -1 & & \\ & -1 & 2 & -1 & \\ & & & \ddots & -1 \\ & & & -1 & 2 \end{pmatrix} \quad (3.2.26)$$

by the F-theory construction [11, 13] or the anomaly cancellation.

Using the formulas in [4, 29], we can determine the Green-Schwarz coupling I_i and the kinetic matrix η^{ij} for the 6d theory $\mathcal{T}_{(*)}^{6d}\{u_i\}$, which is given as

$$I^i = \eta^{ij} I_j = \eta^{ij} c_2(F_{\mathfrak{g}_j}) - \frac{1}{4} K^i p_1(T) + h^\vee(\mathfrak{g}_i) c_2(F_R) - c_2(F_{\mathfrak{f}_i}). \quad (3.2.27)$$

In our case, $K^i = 2 - \eta^{ii}$ is given as $K^1 = 1, K^i = 0$ ($i \geq 2$) and $h^\vee(\mathfrak{g}_i)$ is $h^\vee(\mathfrak{g}_1) = 1, h^\vee(\mathfrak{g}_i) = h^\vee(\mathfrak{su}(u_i)) = u_i$ ($i \geq 2$).

Then the relevant part of the Green-Schwarz contribution I^{GS} is

$$\begin{aligned}
 I^{\text{GS}} &\supset \frac{1}{32} \eta_{ij} K^i K^j p_1(T)^2 - \frac{1}{4} \eta_{ij} K^i h^\vee(\mathfrak{g}_j) p_1(T) c_2(F_R) + \frac{1}{4} \eta_{ij} K^i c_2(F_{\mathbb{F}_j}) \\
 &= \frac{N}{32} p_1(T)^2 - \frac{1}{4} \left(N + \sum_{i=2}^N (N+1-i) u_i \right) p_1(T) c_2(F_R) \\
 &\quad + \frac{1}{4} \sum_{i=1}^N (N+1-i) p_1(T) c_2(F_{\mathbb{F}_i}).
 \end{aligned} \tag{3.2.28}$$

Here we have used the explicit form of the inverse η_{ij} of the matrix η^{ij} ;

$$\eta_{ij} = \begin{pmatrix} N & N-1 & N-2 & \cdots & 1 \\ N-1 & N-1 & N-2 & \cdots & 1 \\ N-2 & N-2 & N-2 & \cdots & 1 \\ \vdots & \vdots & \vdots & \ddots & \vdots \\ 1 & 1 & 1 & \cdots & 1 \end{pmatrix}. \tag{3.2.29}$$

Therefore, the Green-Schwarz contribution to the 4d conformal anomalies are

$$\delta n_v = -2N + 12 \left(N + \sum_{i=2}^N (N+1-i) u_i \right), \tag{3.2.30}$$

$$\delta n_h = 28N + 12 \left(N + \sum_{i=2}^N (N+1-i) u_i \right), \tag{3.2.31}$$

$$\delta k_i = 12(N+1-i). \tag{3.2.32}$$

Adding the contribution from the massless multiplets, the total 4d conformal anomalies are

$$n_v = 11N + \sum_{i=2}^N (u_i^2 - 1 + 12(N+1-i) u_i), \tag{3.2.33}$$

$$n_h = 40N + \sum_{i=2}^N (2u_i^2 + 12(N+1-i) u_i) - \sum_{i=2}^{N-1} u_i u_{i+1}, \tag{3.2.34}$$

$$k_i = 12(N+1-i) + 2u_i \quad (i = 1, \dots, N). \tag{3.2.35}$$

Additionally, the complex dimension of the Coulomb branch of $\mathcal{T}^{\text{4d}}\{u_i\}$ is just the sum of the number of 6d tensors and the ranks of the gauge groups;

$$\dim_{\mathbb{C}} \text{Coulomb} = \sum_{i=2}^N (u_i - 1) + N = 1 + \sum_{i=2}^N u_i. \tag{3.2.36}$$

3.2.2.2. Central charges of $\mathbb{T}_K\{Y_1, Y_2, Y_3\}$ from class S formulas

In this subsection we calculate the conformal anomalies of the class S theory $\mathbb{T}_K\{Y_1, Y_2, Y_3\}$. First, we briefly recall the central charge formulas in [73, 80].

Let $Y^\top = [\ell_1, \dots, \ell_N]$ be the partition of K obtained by taking the transpose of the Young diagram Y . The pole structure $\{p_k\}$, $k = 1, \dots, Y - m$ of Y is defined by

$$\begin{cases} p_1 = 0, \\ p_{k+1} - p_k = 0 & \text{if } k \text{ is equal to } \ell_i \text{ for some } i, \\ p_{k+1} - p_k = 1 & \text{otherwise,} \end{cases} \quad (3.2.37)$$

which can be summarized as

$$\{p_k\} = \{0, 1, 2, \dots, \ell_1 - 1, \ell_1 - 1, \ell_1, \dots, \ell_1 + \ell_2 - 2, \dots, K - m\}. \quad (3.2.38)$$

For the class S theory $\mathbb{T}_K\{Y_1, Y_2, Y_3\}$, the number d_k of the Coulomb branch operators with dimension k is given as¹³

$$d_k = 1 - 2k + \sum_{i=1}^3 p_k^{(i)} \quad (3.2.39)$$

where $\{p_k^{(i)}\}$ is the pole structure of Y_i . The effective number of vectors n_v is

$$n_v = \sum_{k=2}^K (2k - 1) d_k, \quad (3.2.40)$$

and the formula for n_h is

$$n_h = -\frac{4}{3}(K^3 - K) + \sum_{n=1}^3 f(Y_n), \quad (3.2.41)$$

$$f(Y) = \frac{1}{2} \left(-K + \sum_i \ell_i^2 \right) + \sum_{k=2}^K (2k - 1) p_k. \quad (3.2.42)$$

Let us apply the formulas (3.2.39), (3.2.40) and (3.2.41) to the class S theory $\mathbb{T}_K\{Y_1, Y_2, Y_3\}$ where $K = 6N + n_7 + n_8$, Y_1 is defined by (3.2.3), $Y_2 = [2N + n_7 + n_8, 2N, 2N]$ and $Y_3 = [3N +$

¹³The formulas below are valid only when $\sum_i p_k^{(i)} \geq 2k - 1$. When $u_i = 0$ which corresponds to the higher rank E_6 Minahan-Nemeschansky theory, the pole structure for the class S description violates this bound. That case was studied well in [18] as already mentioned.

$n_7, 3N + n_8]$. After some calculation, we obtain

$$n_v = 10N + 1 + \sum_{i=2}^N (u_i^2 + 12(N+1-i)u_i), \quad (3.2.43)$$

$$n_h = 40N + \sum_{i=2}^N (2u_i^2 + 12(N+1-i)u_i) - \sum_{i=2}^{N-1} u_i u_{i+1}, \quad (3.2.44)$$

$$\dim_{\mathbb{C}} \text{Coulomb} = \sum_{k=2}^K d_k = 1 + \sum_{i=2}^N u_i, \quad (3.2.45)$$

which agree with the results (3.2.33), (3.2.34) and (3.2.36).

We can also check the agreement of flavor groups and their central charges. As explained in [73], the theory $\mathbb{T}_K\{Y_1, Y_2, Y_3\}$ has the flavor group (up to $u(1)$ factors)

$$\mathfrak{su}(\ell_1 - \ell_2)_{2\ell_1} \times \mathfrak{su}(\ell_2 - \ell_3)_{2L_2} \times \cdots \times \mathfrak{su}(\ell_{N-n_6})_{12N} \times \mathfrak{su}(2)_{12N}, \quad (3.2.46)$$

where the subscripts denote the flavor central charges and L_i is defined by $L_i = \sum_{j=1}^i \ell_j$. There is an additional $\mathfrak{su}(2)_{2K}$ when $n_7 = n_8$, and moreover $\mathfrak{su}(2)_{12N}$ enhances to $\mathfrak{su}(3)_{12N}$ when $n_7 = n_8 = 0$. When $n_8 \neq n_7 \neq 0$, $\mathfrak{su}(\ell_{N-i+1} - \ell_{N-i+2})_{2L_{N-i+1}} = \mathfrak{su}(2u_i - u_{i+1} - u_{i-1})_{12(N+1-i)+2u_i}$ is nothing but the flavor group \mathfrak{f}_i and its central charge of $\mathcal{F}^{4d}\{u_i\}$, and $\mathfrak{su}(2)_{12N}$ should be identified with \mathfrak{f}_1 . One can also match the flavor groups and central charges for other cases.

In the discussion so far, we only considered the 4d theory $\mathbb{T}_K\{Y_1, Y_2, Y_3\}$. It is straightforward to compute those quantities for the 4d theory $\mathbb{T}_{K^*}\{Y_1, Y_2^*, Y_3^*\}$ and check the agreement with the results in Sec 3.2.2.1.

3.3. Compactification of theories higgsable to $\mathcal{F}_G^{(2,0)}$

In this section, we investigate S^1 and T^2 compactification of a 6d SCFT \mathcal{T} higgsable to $\mathcal{F}_G^{(2,0)}$ with some A, D, E root system G . At first, we will make a claim about compactifications of a general theory higgsable to $\mathcal{F}_G^{(2,0)}$:

When a 6d $\mathcal{N}=(1,0)$ theory \mathcal{T} is higgsable to $\mathcal{F}_G^{(2,0)}$, the circle compactification ${}^{5d}\mathcal{T}$ can be decomposed as

$${}^{5d}\mathcal{T} = {}^{5d}\mathcal{S}\{G\}/G_{R_6} \quad (3.3.1)$$

where ${}^{5d}\mathcal{S}\{G\}$ is a 5d $\mathcal{N}=1$ SCFT with G (or larger) flavor, and $/G_{R_6}$ denotes the $\mathcal{N}=1$ gauging with coupling $\frac{8\pi^2}{g^2} = \frac{1}{R_6}$ with R_6 being the circle radius. On the torus compactification, we have

$${}^{4d}\mathcal{T} = {}^{4d}\mathcal{S}\{G\}/G_{\tau} \quad (3.3.2)$$

with ${}^{4d}\mathcal{S}\{G\}$ being the circle compactification of the 5d SCFT ${}^{5d}\mathcal{S}\{G\}$, and $/G_{\tau}$ denotes 4d $\mathcal{N}=2$ gauging with marginal coupling τ .

At this stage we do not know whether ${}^{4d}\mathcal{S}$ is superconformal or not.

Further, for conformal matter $\mathcal{T}_{N-1}^{(g,g)}$, we observe

The theory ${}^{4d}\mathcal{S}\{G\}$ can be further decomposed as

$${}^{4d}\mathcal{S}\{G\} = ({}^{4d}\mathcal{U}\{G, H\} \times {}^{4d}\mathcal{V}\{H\})/H_{\text{IRF}} \quad (3.3.3)$$

with a certain 4d $\mathcal{N}=2$ SCFTs ${}^{4d}\mathcal{U}$ and ${}^{4d}\mathcal{V}$ whose flavors are indicated in the bracket, and the gauging $/H_{\text{IRF}}$ with respect to a certain IR free gauge group H .

We expect that this property is common for general theories higgsable to $\mathcal{T}_G^{(2,0)}$. An important consequence is

The 4d theory ${}^{4d}\mathcal{T}$ flows to a fixed point composed of two SCFTs:

$${}^{4d}\mathcal{T} \xrightarrow{\text{flow}} {}^{4d}\mathcal{U}\{G, H\}/G_\tau \times {}^{4d}\mathcal{V}\{H\} \text{ plus free matters} \quad (3.3.4)$$

at the most singular point of the Coulomb branch, when none of Wilson lines are introduced, if ${}^{4d}\mathcal{V}$ is not empty.

For the (A, A) conformal matter $\mathcal{T}_{N-1}^{(\mathfrak{su}(k), \mathfrak{su}(k))}$, the SCFTs ${}^{4d}\mathcal{U}$, ${}^{4d}\mathcal{V}$ are identified with certain class S SCFTs:

When the 6d theory \mathcal{T} is the (A, A) conformal matter $\mathcal{T}_{N-1}^{(\mathfrak{su}(k), \mathfrak{su}(k))}$ with $k < N$, the 4d SCFTs ${}^{4d}\mathcal{U}$, ${}^{4d}\mathcal{V}$ are

$${}^{4d}\mathcal{U} = \mathbb{T}_k\{F, F, F\}, \quad {}^{4d}\mathcal{V} = \mathbb{T}_N\{[N-k, 1^N], F, F\}. \quad (3.3.5)$$

Therefore, the 4d theory ${}^{4d}\mathcal{T}_{N-1}^{(\mathfrak{su}(k), \mathfrak{su}(k))}$ is

$${}^{4d}\mathcal{T}_{N-1}^{(\mathfrak{su}(k), \mathfrak{su}(k))} = \frac{\mathbb{T}_k\{F, F, F\} \times S_N\langle T_\tau^2 \rangle\{[N-k, 1^N]\}}{\text{diag. of } \text{SU}(k)}, \quad (3.3.6)$$

where $S_N\langle C \rangle\{\emptyset\}$ denotes the class S theory whose Gaiotto curve is C with puncture \emptyset .

Also for $k = N$ and $k > N$ cases, the 4d theories are determined. Further, the (D, D) conformal matter case will be also studied in detail.

Closing one of the $\mathfrak{su}(k)$ flavors of both side of (3.3.6), one obtain

$${}^{4d}\mathcal{T}_{N-1}^{(\mathfrak{su}(k), \mathfrak{su}(k))} = S_N\langle T_\tau^2 \rangle\{[N-k, 1^N]\} \quad (3.3.7)$$

since the class S theory $\mathbb{T}\{F, F\}$, whose Gaiotto curve is a sphere with only two punctures, is gapped. This result leads us to the observation:

When the endpoint tensor branch quiver contains a tensor mode (a^k, B^k) which is not coupled with any vector fields by the coupling $a^k \text{Tr} F \wedge \star F$, then the torus compactified theory ${}^{4d}\mathcal{T}$ flow into a fixed point composed of a single 4d SCFT.

Actually this is shown for 6d theories higgsable to $\mathcal{T}_G^{(2,0)}$ with $G = A, D$ in [16], although the proof will not be exposed in this thesis.

3.3.1. General structure of theories higgsable to $\mathcal{T}_G^{(2,0)}$

In this subsection, we explain the structure of 6d $\mathcal{N}=(1,0)$ theories we want to compactify and give general arguments for the S^1/T^2 compactification of these theories. The results in this section will be checked using several examples in the following sections.

3.3.1.1. 6d SCFTs higgsable to $\mathcal{T}_G^{(2,0)}$

We have seen concrete examples of 6d SCFTs Higgsable to $\mathcal{T}_G^{(2,0)}$ with $G = A_k$ in Section 2.4, which was the conformal matters $\mathcal{T}_N^{(\mathfrak{g},\mathfrak{g})}$ and their variant $\mathcal{T}_N^{(\mathfrak{g},\mathfrak{g})}\{\mathcal{O}_L, \mathcal{O}_R\}$. Here we briefly summarize general properties of a 6d SCFT \mathcal{T} higgsable to $\mathcal{T}_G^{(2,0)}$. Most of them have already been recognized in the concrete cases in Section 2.4.

First of all, by the term a 6d SCFT \mathcal{T} higgsable to $\mathcal{T}_G^{(2,0)}$, we mean that at the most singular point of the contracted subspace (where one can reach from a generic point by shrinking only the tensor modes with $\eta^{kk} = 1$) of the tensor branch, which we call the endpoint according to [11], the charge matrix η^{ij} in terms of the remaining (not shrunken) tensor modes is the Cartan matrix of type $G = A, D, E$. For example, the endpoint configuration of the conformal matter $\mathcal{T}_N^{(\mathfrak{g},\mathfrak{g})}$ is (2.4.27) with N remaining tensor modes. Between two nodes of (2.4.27), a minimal conformal matter $\mathcal{T}_0^{(\mathfrak{g},\mathfrak{g})}$ exists as a generalized bifundamental matter. The charge matrix is the Cartan of A_N type. We can Higgs all the flavor and gauge algebras \mathfrak{g} obtaining the $\mathcal{N}=(2,0)$ theory $\mathcal{T}_{A_N}^{(2,0)}$.

As a technical assumption, we do not consider theories like $\mathcal{T}_N^{(\text{usp},\text{usp})}$, which is supposed to have a Higgs flow into $\mathcal{T}_{A_N}^{(2,0)}$, although the endpoint configuration is not (2.4.27).

There is also theories higgsable to $\mathcal{N}=(2,0)$ theory $\mathcal{T}_G^{(2,0)}$ with $G = D, E$ [11, 12]. When all gauge algebras are \mathfrak{su} type and the charge matrix η^{ij} is a Cartan matrix, the gauge anomaly cancellation condition requires that every $\mathfrak{su}(k)$ gauge algebra should have $2k$ fundamentals.¹⁴ Therefore, for example, there is a theory whose tensor branch structure is

$$\begin{array}{cccccc} \mathfrak{su}(k) & \mathfrak{su}(2k) & \mathfrak{su}(2k) & \mathfrak{su}(2k) & [\mathfrak{su}(2k)] & \\ 2 & 2 & 2 & 2 & & \\ & 2 & & & & \\ & \mathfrak{su}(k) & & & & \end{array}, \quad (3.3.8)$$

which is higgsable to $\mathcal{T}_{D_5}^{(2,0)}$. There are also $E_{6,7,8}$ shaped quivers which are higgsable to $\mathcal{T}_{E_{6,7,8}}^{(2,0)}$.

If we allow ourselves to use gauge algebras other than \mathfrak{su} , one example of solutions for the

¹⁴This condition is the same as the conformality condition of 4d $\mathcal{N}=2$ quiver theory with \mathfrak{su} gauge algebras. Intuitive understanding of this coincidence seems to be absent.

anomaly cancellation is

$$\begin{array}{cccccc}
\mathfrak{su}(2) & \mathfrak{so}(7) & \mathfrak{usp}(0) & \mathfrak{so}(9) & \mathfrak{usp}(2) & [\mathfrak{so}(11)] \\
2 & 3 & 1 & 4 & 1 & \\
& 2 & & & & \\
& \mathfrak{su}(2) & & & &
\end{array} \tag{3.3.9}$$

where the $\mathfrak{su}(2) \oplus \mathfrak{so}(7) \oplus \mathfrak{su}(2)$ gauge subalgebra has a half-hyper with the representation $(\mathbf{2}, \mathbf{8}, \mathbf{1}) \oplus (\mathbf{1}, \mathbf{8}, \mathbf{2})$ with $\mathbf{8}$ being the spin representation of $\mathfrak{so}(7)$. The endpoint configuration is

$$\begin{array}{cccc}
\mathfrak{su}(2) & \mathfrak{so}(7) & \mathfrak{so}(9) & [\mathfrak{so}(11)] \\
2 & 2 & 2 & \\
& 2 & & \\
& \mathfrak{su}(2) & &
\end{array}, \tag{3.3.10}$$

which indicates the theory is higgsable to $\mathcal{T}_{D_4}^{(2,0)}$. Note that in this case between $\mathfrak{so}(2k-1)$ and $\mathfrak{so}(2k+1)$ gauge of flavor algebra with $k=4,5$ there are minimal conformal matters $\mathcal{T}_0^{(\mathfrak{so}(2k), \mathfrak{so}(2k))}$ behave as generalized bifundamentals.

In general, the endpoint configuration of a theory \mathcal{T} which is higgsable to $\mathcal{T}_G^{(2,0)}$ can be recognized as G -shaped generalized quiver with gauge groups \mathfrak{g}_i with generalized bifundamental matter \mathcal{H}_{ij} charged under $\mathfrak{g}_i \oplus \mathfrak{g}_j$ and generalized matters \mathcal{H}_i charged under \mathfrak{g}_i . Since at the endpoint the tensor modes of those generalized matters should be completely shrunk, those are very-higgsable. The generalized matter theories can be determined using F-theory [12, 13], and a (not necessarily complete) list of possible combinations $(\mathfrak{g}_i, \mathfrak{g}_j, \mathcal{H}_{ij})$ is given in Table 3.1. A generalized singly charged matter \mathcal{H}_i can be either fundamental hypers or E-string theories.

\mathfrak{g}_i	\mathfrak{g}_j	\mathcal{H}_{ij}
$\mathfrak{su}(k_1)$	$\mathfrak{su}(k_2)$	$(\mathbf{k}_1, \mathbf{k}_2)$
$\mathfrak{so}(2k_1)$	$\mathfrak{so}(2k_2)$	$\mathcal{T}_0^{(\mathfrak{so}(2k), \mathfrak{so}(2k))}$ ($k = \lfloor (k_1 + k_2)/2 \rfloor$)
$\mathfrak{su}(2)$	\mathfrak{g}_2	$\frac{1}{2}(\mathbf{2}, \mathbf{7} \oplus \mathbf{1})$
$\mathfrak{su}(2)$	$\mathfrak{so}(7)$	$\frac{1}{2}(\mathbf{2}, \mathbf{8})$
\mathfrak{e}_k	\mathfrak{e}_k	$\mathcal{T}_0^{(\mathfrak{e}_k, \mathfrak{e}_k)}$

Table 3.1.: The generalized hyper \mathcal{H}_i . The boldface number means a hyper with the representation with the specified dimension, and $\frac{1}{2}$ before the representation mean a half-hyper. Maybe only a subalgebra of $\mathfrak{g}_i \oplus \mathfrak{g}_j$ is gauged by dynamical vector multiplets, and in that case the commutant of the gauged subalgebra behave as a flavor algebra. Note that the minimal conformal matters $\mathcal{T}_0^{(\mathfrak{su}(k), \mathfrak{su}(k))}$ and $\mathcal{T}_0^{(\mathfrak{so}(2k), \mathfrak{so}(2k))}$ has flavor symmetry $\mathfrak{su}(2k)$ and $\mathfrak{so}(4k)$ respectively which are larger than what is obvious from the M-theory construction (but still obvious from the tensor branch structure at a generic point), therefore the first two lines are possible when $k_1 \neq k_2$.

3.3.1.2. Non-higgsable component and non-renormalization

If we go to the Higgs branch of the theory as far as possible from the endpoint configuration, we get a non-higgsable theory which is the $\mathcal{N}=(2,0)$ theory of the type G . The Higgs branch is the same in any dimensions, and the Higgs moduli fields and the tensor/Coulomb moduli fields do not mix with each other in the effective action. We can consider a subspace \mathcal{C}_T of the tensor/Coulomb moduli space where only the moduli which originate from the tensor multiplets of the 6d theory get vev.¹⁵ Then, the effective action (or more specifically the kinetic terms) of moduli fields parameterizing \mathcal{C}_T in 6d/5d/4d is the same as that of the $\mathcal{N}=(2,0)$ theory in 6d/5d/4d because these two theories are smoothly connected by a Higgs deformation which does not affect the tensor/Coulomb effective action.

The difference between the general theory we are considering and the $\mathcal{N}=(2,0)$ theory is that the general theory contains more massless degrees of freedom other than the moduli fields of \mathcal{C}_T . However, we emphasize again that the effective action of \mathcal{C}_T moduli fields and in particular the position of the singular loci on \mathcal{C}_T are the same as in the $\mathcal{N}=(2,0)$ theory. In other words, the moduli fields of \mathcal{C}_T are not renormalized by the existence of additional massless degrees of freedom. Due to $\mathcal{N}=(2,0)$ supersymmetry of the Higgsed theory, they are not renormalized at all. This is quite similar situation to what we saw about very-higgsable theories in Subsection 3.1.1.

3.3.1.3. S^1 compactification to five dimensions at the origin

Let us fix a 6d theory \mathcal{T}^{6d} that can be Higgsed to an $\mathcal{N}=(2,0)$ theory of type G , and consider its S^1 compactification. We go to the origin of the moduli space of the 6d theory at which we get the 6d SCFT, and compactify it on a circle with radius R . We do not include any Wilson lines on S^1 which correspond to mass deformations in 5d. In this setup, our conjecture is the following:

The 5d theory ${}^{5d}\mathcal{T}$ obtained by the S^1 compactification at the most singular point of the moduli and parameter space is given by an $\mathcal{N}=1$ vector multiplet of gauge group G which is coupled to a 5d SCFT we denote as ${}^{5d}\mathcal{S}\{G\}$, whose G symmetry is gauged by the vector multiplet:

$${}^{5d}\mathcal{T} = {}^{5d}\mathcal{S}/G_R. \quad (3.3.11)$$

The gauge coupling of the vector multiplet is given by $8\pi^2/g_G^2 = R^{-1}$.

Here, the groups listed inside $\{\dots\}$ are the flavor symmetries, and our normalization of the gauge coupling is such that $8\pi^2/g_G^2$ is the one-instanton action. We also note here that, when all \mathfrak{g}_i are \mathfrak{su} gauge algebras and all matters connecting \mathfrak{su} gauge algebras are hypers, ${}^{5d}\mathcal{S}\{G\}$ actually has $G \times G$ symmetry. In that case, the G flavor symmetry in the notation ${}^{5d}\mathcal{S}\{G\}$ denotes the diagonal subgroup of the $G \times G$ symmetry.

The main reason behind this conjecture is the following. In 6d, we can higgs the theory to obtain the $\mathcal{N}=(2,0)$ theory of type G . If we compactify it on this Higgs branch, we get $\mathcal{N}=2$

¹⁵ Since the 6d theory has the Higgs branch on which the theory flows to the $\mathcal{N}=(2,0)$ theory along \mathcal{C}_T , there is also a subspace of the 5d/4d Coulomb branch where the corresponding branch opens. This clearly defines the subspace \mathcal{C}_T in 5d/4d.

super Yang-Mills in 5d with gauge group G , and in particular, we get a vector multiplet with gauge coupling $8\pi^2/g_G^2 = R^{-1}$. Now we slowly turn off the Higgs vev. The important point is that the Higgs moduli and Coulomb moduli do not mix with each other. Then the existence of the vector multiplet with the gauge coupling $8\pi^2/g_G^2 = R^{-1}$ does not change in the process of turning off the Higgs vev, and hence the vector multiplet exists even at the origin of the moduli space. This establishes the fact that the vector multiplet with gauge group G and gauge coupling $8\pi^2/g_G^2 = R^{-1}$ exists in the 5d theory after compactification of the 6d SCFT.

The existence of the vector multiplet can be regarded as a kind of no-go theorem; the 5d theory cannot be completely superconformal, because we always have the IR free vector multiplet. Our conjecture is that this vector multiplet is the only non-SCFT component in 5d, and the rest of the theory is really an SCFT which we denoted as ${}^{5d}\mathcal{S}\{G\}$. When G is trivial, that is, when there are no (-2) -curves in the endpoint, the 6d theory is very higgsable. In this case, our conjecture above says that the 5d theory obtained by S^1 compactification of a 6d very higgsable theory is really a 5d SCFT. This statement has been indeed established in the previous section.¹⁶

In the case of the $\mathcal{N}=(2,0)$ theory, our 5d SCFT is just a hypermultiplet in the adjoint representation of G . The story of the general case is quite similar to the case of the $\mathcal{N}=(2,0)$ theory by replacing the adjoint hypermultiplet with a strongly coupled 5d SCFT ${}^{5d}\mathcal{S}\{G\}$. For example, instantons of the G vector field is expected to correspond to the Kaluza-Klein modes of the S^1 compactification as in [87, 88].

Tensor branch effective action in 5d We want to discuss the consequences of our conjecture. Before doing that, we mention the 5d effective action on the endpoint configuration.

In 6d, the tensors and vectors remaining in the endpoint configuration have the effective (pseudo-)action (2.1.16) with η^{ij} being the Cartan matrix of G . After dimensional reduction to 5d, we define $\Phi_i = Ra_i$ and $F_{i,\mu\nu}^{\text{tens}} = RH_{i,\mu\nu 5}$ and obtain

$$\int \eta^{ij} \left(-\frac{4\pi^2}{2R} (d\Phi_i \wedge \star d\Phi_j + F_i^{\text{tens}} \wedge \star F_j^{\text{tens}}) + 2\pi\Phi_i \left(\frac{1}{4} \text{Tr} F_j \wedge \star F_j \right) + 2\pi A_i^{\text{tens}} c_2(F_j) \right). \quad (3.3.12)$$

where A_i^{tens} is the vector potential of F_i^{test} . Do not confuse the field strength F_i the non-abelian gauge algebra \mathfrak{g}_i which exists in 6d with the abelian field strength F_i^{tens} coming from the 6d tensor H_i .

The configuration of (-2) -curves defines a Dynkin diagram. Let H^i be the Cartan element of the $SU(2)$ subalgebra of the node i normalized as $\text{tr}(H^i H^j) = \eta^{ij}$, where tr is normalized in such a way that it coincides with the trace in the fundamental representation in $SU(2)$ subalgebras. Then Φ_i and F_i^{tens} can be identified as the Cartan part of the vector multiplet of the 5d gauge group G

¹⁶There, it was shown that the T^2 compactification of very higgsable theory is a 4d SCFT, and the structure of the singularities on its Coulomb branch was also completely fixed. Taking the limit of very thin T^2 , we can obtain the singularity structure of the Coulomb branch of the 5d theory, which shows that the origin of the 5d theory is superconformal.

as $\Phi_G = H^i \Phi_i$ and $F_G = 2H^i F_i^{\text{tens}}$. Then the above action can be rewritten as

$$\int \left(-\frac{4\pi^2}{g_G^2} \text{tr}(d\Phi_G \wedge \star d\Phi_G + F_G \wedge \star F_G) + 2\pi \text{tr}(H^j \Phi_G) \left(\frac{1}{4} \text{Tr} F_j \wedge \star F_j \right) + 2\pi \text{tr}(H^j A_G) c_2(F_j) \right), \quad (3.3.13)$$

where $8\pi^2/g_G^2 = R^{-1}$. This action is valid when the Coulomb vev of Φ_G is generic. The first two terms are the action of the vector multiplet for the gauge group G (on the Coulomb branch), while the last two terms are the action of the gauge groups \mathfrak{g}_i exist in the endpoint configuration.

Mass deformation of 5d SCFT and 5d quiver. Now let us see the implication of our conjecture. On the 6d tensor branch, we have a quiver gauge theory with gauge groups \mathfrak{g}_i . Bifundamentals and fundamentals \mathcal{H}_{ij} are generalized matters which are very higgsable. If we compactify this tensor branch theory to 5d, we get the same quiver theory in 5d plus $U(1)^{r_G}$ vectors. The gauge couplings are determined by the vev of Φ_G as in (3.3.13). The bifundamentals and fundamentals are 5d version of the very higgsable theories.

On the other hand, we conjectured that the 5d theory at the origin of the moduli space is a system in which a 5d SCFT ${}^{5d}\mathcal{S}\{G\}$ is coupled to the G gauge field. Going to the tensor branch in 6d corresponds to giving vev to the adjoint scalar Φ_G of the vector multiplet. The adjoint vev gives mass deformation of this 5d SCFT ${}^{5d}\mathcal{S}\{G\}$. If we take $R \rightarrow 0$ limit, the remaining 5d $U(1)^{r_G}$ vectors just decouples. Therefore, our conjecture requires that the mass deformation of the ${}^{5d}\mathcal{S}\{G\}$ flows under RG flow to the 5d quiver,

$${}^{5d}\mathcal{S}\{G\} \xrightarrow{\text{mass deformation}} \text{the 5d quiver theory}, \quad (3.3.14)$$

where the quiver theory is the one obtained from the 6d tensor branch. Furthermore, (3.3.13) tells us that the gauge coupling of the gauge field with gauge algebra \mathfrak{g}_i at the quiver node i is given by the mass deformation $\langle \Phi_G \rangle = m_G$ as

$$\frac{8\pi^2}{g_i^2} = \text{tr}(H^i m_G), \quad (3.3.15)$$

where we have used the fact that our normalization is such that $\frac{1}{4} \text{Tr} F^2$ is 1 in one-instanton.

Let us state the above process in the opposite direction of RG flows. Our conjecture requires that the 5d quiver gauge theory must have a UV fixed point. Furthermore, there must be an enhanced global G symmetry in the UV fixed point whose Cartan part is identified with the topological $U(1)$ symmetries associated to instantons of gauge groups in the IR quiver.

Let us focus our attention to the case in which the gauge group \mathfrak{g}_i on the i th node of the endpoint quiver is $\mathfrak{su}(N_i)$ where the rank N_i can take arbitrary values as long as anomaly cancellation condition is satisfied. In this case, the corresponding 5d quiver theory is expected to have a UV fixed point. The enhanced global symmetry in the UV fixed point is actually two copies of G [89, 90]. We can take the diagonal subgroup G_{diag} , and deform the UV SCFT by mass deformation of G_{diag} by m_G . One of G flavor comes from instanton $U(1)$ symmetries as mentioned above, and the other comes from the $U(1)$ symmetries that act on bifundamental matters between

adjacent \mathfrak{su} gauge groups in the quiver. Then the IR gauge coupling of the quiver is really given by the equation (3.3.15)¹⁷ Therefore, our conjecture works very well in this class of theories.

More general case involves strongly interacting generalized matters. Then, it is not straightforward to study their 5d quivers. Nevertheless, as we will discuss examples of $\mathcal{T}_N^{(g,g)}$ in Subsection 3.3.3.3, such a quiver theory with generalized bifundamentals is dual to more conventional $SU(N)$ quiver gauge theories with ordinary hypermultiplets. Existence of such examples supports our general conjecture.

3.3.1.4. T^2 compactification to four dimensions

Let us denote by ${}^{4d}\mathcal{S}\{G\}$ the theory which is obtained by the S^1 compactification of the 5d SCFT ${}^{5d}\mathcal{S}\{G\}$. This 4d theory ${}^{4d}\mathcal{S}\{G\}$ may be an SCFT or may contain IR free gauge groups; we will discuss this point in detail later. Then, by compactifying the 5d theory of the previous subsection further on S^1 , we get a theory in which the 4d vector multiplet of the gauge group G is coupled to ${}^{4d}\mathcal{S}\{G\}$. This is the theory we obtain by T^2 compactification. Therefore, the problem of T^2 compactification of the 6d SCFT is reduced to the problem of S^1 compactification of the 5d SCFT ${}^{5d}\mathcal{S}\{G\}$.

Let us determine the gauge coupling of the G gauge field. For this purpose, we again use the reasoning of the previous subsections. We can higgs the theory to obtain $\mathcal{N}=4$ super Yang-Mills in 4d. The Higgs and Coulomb moduli do not mix, so the higgsing does not affect the gauge coupling of the G gauge field. The gauge field of $\mathcal{N}=4$ super Yang-Mills is conformal with the gauge coupling given by the complex modulus τ of the T^2 . Therefore, the G gauge group before higgsing must also be conformal (i.e., has vanishing beta function) with the gauge coupling τ . The $SL(2, \mathbb{Z})$ of the T^2 acts on τ , so the 4d theory has a nontrivial $SL(2, \mathbb{Z})$ S-duality group. The fact that G gauge group is conformal means that the theory ${}^{4d}\mathcal{S}\{G\}$ contributes to the beta function by the same amount as that of one adjoint hypermultiplet.

Quiver on the tensor branch. By going to the tensor branch in 6d and compactifying it on T^2 , or equivalently by giving a vev to the adjoint scalar of the G vector multiplet and mass-deforming ${}^{4d}\mathcal{S}\{G\}$ by that vev, we get a quiver gauge theory with generalized matters. The Cartan of the G gauge field becomes $U(1)^{\text{rank } G}$ free vector fields.

We now show that gauge groups of the quiver are conformal. For this purpose, it is enough to concentrate on a single tensor mode and the gauge field coupled to it in the endpoint. A little more generally, let \mathfrak{g} be a gauge group supported on a tensor mode (a^k, B^k) with $\eta^{kk} = n$. The generalized matters coupled to this gauge group is very-higgsable, and we denote the 6d anomaly polynomial of this very-higgsable theory as $I[\text{gen. matter}]$. Then the part of the anomaly polynomial of the total system containing the field strength of \mathfrak{g} is given as

$$I[\text{gen. matter}] + I[\mathfrak{g} \text{ vector}] + I_{GS}, \quad (3.3.16)$$

¹⁷See the last equation in section 3.4 of [90]. The m_{\pm} in that paper is taken to be m_G here, and H_i there is $\frac{1}{2}H^i$ here.

I^{GS} is the Green-Schwarz contribution. From (A.0.3),(2.1.24),(2.1.25),(2.1.40) they contain

$$I[\mathfrak{g} \text{ vector}] \supset -\frac{h_{\mathfrak{g}}^{\vee}}{12} p_1(T) c_2(F_{\mathfrak{g}}), \quad (3.3.17)$$

$$I_{\text{GS}} \supset \frac{1}{2n} \left(\frac{2-n}{4} p_1(T) - n c_2(F_{\mathfrak{g}}) \right)^2 \supset -\frac{2-n}{4} p_1(T) c_2(F_{\mathfrak{g}}). \quad (3.3.18)$$

The terms containing $c_2(F_{\mathfrak{g}})$ must be cancelled in the total anomaly, so we get

$$I[\text{gen. matter}] \supset \frac{1}{48} (4h_{\mathfrak{g}}^{\vee} + 12(2-n)) p_1(T) c_2(F_{\mathfrak{g}}). \quad (3.3.19)$$

Using (3.1.31), 4d \mathfrak{g} flavor central charge of the compactified very-higgsable generalized matter is $k_{\mathfrak{g}} = 4h_{\mathfrak{g}}^{\vee} + 12(2-n)$. This $k_{\mathfrak{g}}$ is the contribution of the generalized matter theory to the 4d beta function of the \mathfrak{g} gauge group, in the normalization that the vector multiplet contribution is $-4h_{\mathfrak{g}}^{\vee}$. Therefore, the beta function of \mathfrak{g} is proportional to $k_{\mathfrak{g}} - 4h_{\mathfrak{g}}^{\vee} = 12(2-n)$.

From this we find the following fact: pick a tensor mode (a_k, B_k) with $\eta^{kk} = n$, supporting a gauge multiplet \mathfrak{g} which is coupled to very-higgsable matters. In the 4d theory obtained by the T^2 reduction, this gauge multiplet is

- IR free when $n = 1$,
- conformal when $n = 2$, and
- asymptotic free when $n > 2$.

The $n = 1$ case was already shown in Subsection 3.1.1. The $n = 2$ case which is relevant to us here means the gauge groups on the endpoint tensor branch quiver are all conformal in 4d.

The gauge couplings of these conformal gauge groups are determined by the vev of the adjoint scalar Φ_G . When this vev is turned off, we get a more singular theory ${}^{\text{4d}}\mathcal{S}\{G\}$ coupled to the non-abelian G group. We stress that the flow from ${}^{\text{4d}}\mathcal{S}\{G\}$ to the quiver is mass deformation rather than exactly marginal deformation, and hence some information is lost in the quiver theory because massive degrees of freedom are integrated out.

3.3.2. Conformal matters and class S theories: type A

In this subsection and the next, we give concrete examples of the general discussions of the previous section. We focus on conformal matters $\mathcal{F}_N^{(\mathfrak{g}, \mathfrak{g})}$ and their deformation $\mathcal{F}_N^{(\mathfrak{g}, \mathfrak{g})}\{\mathcal{O}_L, \mathcal{O}_R\}$. Some properties of the circle compactified theory ${}^{\text{5d}}\mathcal{F}_N^{(\mathfrak{g}, \mathfrak{g})}$ is already mentioned in Subsection 2.4.4.

3.3.2.1. Conformal matter of A-type

As said in Subsection 2.4.4, if we compactify the conformal matter $\mathcal{F}_N^{(\mathfrak{g}, \mathfrak{g})}$ on S^1 with generic Wilson lines in the diagonal subgroup of the flavor symmetry $\mathfrak{g}_L \times \mathfrak{g}_R$, we get the quiver gauge theory [49] whose nodes form an affine Dynkin diagram of type $\widehat{\mathfrak{g}}$ and each node k of the affine Dynkin diagram has the gauge group $\text{SU}(d_k^{\mathfrak{g}} N)$, where $d_k^{\mathfrak{g}}$ are the so-called marks of the Dynkin

diagram such that the highest root is given by $\sum_k d_k^{\mathfrak{g}} \alpha_k$ where α_k is the k -th simple root. However, our main focus in this paper is to study the most singular theory obtained without flavor Wilson lines.

Here we first consider the A-type conformal matter $\mathcal{T}_{N-1}^{(\mathfrak{su}(k), \mathfrak{su}(k))}$ whose tensor branch structure is

$$\begin{array}{ccccccc} [\mathfrak{su}(k)_L] & \mathfrak{su}(k) & \cdots & \mathfrak{su}(k) & [\mathfrak{su}(k)_R] & & \\ & 2 & \cdots & 2 & & & \end{array} . \quad (3.3.20)$$

The theory is higgsable to $\mathcal{T}_G^{(2,0)}$ with $G = \mathrm{SU}(N)$.

Five dimensions. Following our general discussions of the previous section, we consider a 5d version of the quiver gauge theory of the form (3.3.20). This is a 5d $\mathrm{SU}(k)^{N-1}$ quiver theory with k flavors at each end, and the properties of this theory can be easily read off from the brane web construction of this theory [17, 83, 91] as a D5-NS5 system. The theory has a UV fixed point which we denote as ${}^{\mathrm{5d}}\mathcal{S}_{k,N}$. This 5d theory has global symmetry $\mathrm{SU}(k)_L \times \mathrm{SU}(k)_R \times \mathrm{SU}(N)_L \times \mathrm{SU}(N)_R$, where $\mathrm{SU}(N)_L \times \mathrm{SU}(N)_R$ is the enhanced symmetry.

The theory ${}^{\mathrm{5d}}\mathcal{S}_{k,N}$ itself is an SCFT, but by deforming it by mass term $m_{\mathrm{SU}(N)}$ in the Cartan of the diagonal subgroup of $\mathrm{SU}(N)_L \times \mathrm{SU}(N)_R$, we get the IR $\mathrm{SU}(k)^{N-1}$ quiver theory

$${}^{\mathrm{5d}}\mathcal{S}_{k,N} \xrightarrow{\mathrm{SU}(N) \text{ mass deform}} [\mathrm{SU}(k)_L] - \mathrm{SU}(k) - \cdots - \mathrm{SU}(k) - [\mathrm{SU}(k)_R]. \quad (3.3.21)$$

The gauge coupling is determined by the general formula (3.3.15) which in this case is given by $8\pi^2/g_i^2 = m_{\mathrm{SU}(N),i} - m_{\mathrm{SU}(N),i+1}$ ($i = 1, \dots, N-1$), where $m_{\mathrm{SU}(N)} = \mathrm{diag}(\dots, m_{\mathrm{SU}(N),i}, \dots)$. This is precisely as expected from the brane construction of this theory. Furthermore, this theory has a duality $k \leftrightarrow N$ which can be readily seen from the brane construction. Therefore, if we deform the theory by masses in the Cartan of the diagonal subgroup of $\mathrm{SU}(k)_L \times \mathrm{SU}(k)_R$, we get the IR $\mathrm{SU}(N)^{k-1}$ quiver theory,

$${}^{\mathrm{5d}}\mathcal{S}_{k,N} \xrightarrow{\mathrm{SU}(k) \text{ mass deform}} [\mathrm{SU}(N)_L] - \mathrm{SU}(N) - \cdots - \mathrm{SU}(N) - [\mathrm{SU}(N)_R], \quad (3.3.22)$$

where $\mathrm{SU}(N)_{L,R}$ are flavor symmetries, and there are $k-1$ $\mathrm{SU}(N)$ gauge groups.

Now, our claim is that the compactification of the conformal matter $\mathcal{T}_{N-1}^{(\mathfrak{su}(k), \mathfrak{su}(k))}$ on S^1 is given by the theory ${}^{\mathrm{5d}}\mathcal{S}_{k,N}$ with the diagonal subgroup of $\mathrm{SU}(N)_L \times \mathrm{SU}(N)_R$ gauged,

$$\mathcal{T}_{N-1}^{(\mathfrak{su}(k), \mathfrak{su}(k))} \xrightarrow{S^1} {}^{\mathrm{5d}}\mathcal{S}_{k,N} \{ \mathrm{SU}(k)_L, \mathrm{SU}(k)_R, \mathrm{SU}(N)_L, \mathrm{SU}(N)_R \} / \mathrm{SU}(N)_{\mathrm{diag}} \quad (3.3.23)$$

where the notation of the right hand side means that we are gauging the diagonal subgroup $\mathrm{SU}(N)_{\mathrm{diag}} \subset \mathrm{SU}(N)_L \times \mathrm{SU}(N)_R$ by the $\mathrm{SU}(N)$ vector multiplet.

Let us consider two types of deformation of this 5d theory. The first one is to go to the Coulomb branch of the $\mathrm{SU}(N)$ gauge group by giving a vev to the adjoint scalar $\Phi_{\mathrm{SU}(N)}$. Then, this gives mass deformation of the theory ${}^{\mathrm{5d}}\mathcal{S}_{k,N}$, and we exactly get the dimensional reduction of the 6d quiver (3.3.20).

Next, let us consider mass deformation of the diagonal subgroup of the flavor symmetry $\mathrm{SU}(k)_L \times$

$SU(k)_R$ at the origin of the Coulomb moduli space. This corresponds to introducing flavor Wilson lines on S^1 . In this case, the mass deformation of ${}^{5d}\mathcal{S}_{k,N}$ is given by (3.3.22), but the diagonal subgroup of $SU(N)_L \times SU(N)_R$ is gauged by the gauge group $SU(N)$ as in (3.3.23). Therefore, we get an $SU(N)^k$ necklace quiver theory. This is exactly the one obtained by putting N D4-branes on the A_{k-1} singularity with generic B -flux. In this way, two different 5d IR theories follow from the single strongly interacting 5d SCFT ${}^{5d}\mathcal{S}_{k,N}$.

Four dimensions. The T^2 compactification of the conformal matter $\mathcal{F}_{N-1}^{(su(k),su(k))}$ is now given as

$$\mathcal{F}_{N-1}^{(su(k),su(k))} \xrightarrow{T^2} {}^{4d}\mathcal{S}_{k,N}\{SU(k)_L, SU(k)_R, SU(N)_L, SU(N)_R\}/SU(N)_{\text{diag}}^\tau \quad (3.3.24)$$

where ${}^{4d}\mathcal{S}_{k,N}$ is the 4d theory obtained by the S^1 compactification of ${}^{5d}\mathcal{S}_{k,N}$, and the notation of the right hand side means that we are gauging the diagonal subgroup $SU(N)_{\text{diag}} \subset SU(N)_L \times SU(N)_R$ by the $SU(N)$ vector multiplet with gauge coupling τ . Thus, the problem of T^2 compactification of the conformal matter $\mathcal{F}_{N-1}^{(su(k),su(k))}$ is reduced to the problem of S^1 compactification of ${}^{5d}\mathcal{S}_{k,N}$.

Because of the symmetry $k \leftrightarrow N$ of this theory, we assume $N \geq k$ for the moment. For the purpose of studying ${}^{4d}\mathcal{S}_{k,N}$, we consider the mass deformation (3.3.21) and (3.3.22) in 4d. The right hand side of (3.3.21) is a class S theory of A_{k-1} type on a Riemann sphere with two full punctures and N simple punctures. As discussed above, the gauge couplings are determined by the mass deformation. Then, by tuning the $SU(N)$ mass deformation, we can collide the N simple punctures at a single point and obtain [6],

$$\mathbb{T}_k\{[1^k], [1^k], [1^k]\} - SU(k) - \cdots - SU(k) - SU(k-1) - \cdots - SU(1), \quad (N \geq k) \quad (3.3.25)$$

where there are $N - k + 1$ $SU(k)$'s, and each gauge group is coupled to additional fundamentals if necessary so that the gauge group becomes conformal. The $SU(1)$ is introduced formally. The leftmost $SU(k)$ is coupled to one of the full punctures of $\mathbb{T}_k\{[1^k], [1^k], [1^k]\}$. On the other hand, the right hand side of (3.3.22) is a class S theory of type A_{N-1} on a Riemann sphere with two full punctures and k simple punctures. Then, by tuning the $SU(k)$ masses so that colliding simple punctures, we get (when $N \geq k$),

$$\mathbb{T}_N\{[1^N], [1^N], [N-k, 1^k]\} - SU(k) - SU(k-1) - \cdots - SU(1), \quad (N \geq k) \quad (3.3.26)$$

where $SU(k)$ is coupled to the puncture $[N-k, 1^k]$.

From the above results, we expect that the theory ${}^{4d}\mathcal{S}_{k,N}$ contains both of the theories $\mathbb{T}_k\{[1^k], [1^k], [1^k]\}$ and $\mathbb{T}_N\{[1^N], [1^N], [N-k, 1^k]\}$ when $N \geq k$. We propose that this theory is given by

$${}^{4d}\mathcal{S}_{k,N} = \begin{cases} \mathbb{T}_N\{[1^N], [1^N], [N-k, 1^k]\} - SU(k) - \mathbb{T}_k\{[1^k], [1^k], [1^k]\} & (N > k) \\ \mathbb{T}_N\{[1^N], [1^N], [1^N]\} - [SU(N) + \text{one fund.}] - \mathbb{T}_N\{[1^N], [1^N], [1^N]\} & (N = k) \\ \mathbb{T}_N\{[1^N], [1^N], [1^N]\} - SU(N) - \mathbb{T}_k\{[1^k], [1^k], [k-N, 1^N]\} & (N < k) \end{cases} \quad (3.3.27)$$

where in the $N = k$ case there is one fundamental representation coupled to the middle $SU(N)$

gauge group.

The contribution of the $\mathbb{T}_N\{[1^N], [1^N], [N-k, 1^k]\}$ theory to the beta function of the $SU(k)$ is the same as that of $k+1$ fundamentals when $k < N$. So in each case, the gauge group $SU(k)$ or $SU(N)$ appearing in the above equation has IR free beta function. We will give other justifications of the appearance of the IR free gauge group later in this paper.

We will give more checks of (3.3.27) below, but before doing that, let us complete our task of determining the 4d theory obtained by compactification of the 6d conformal matter $\mathcal{F}_{N-1}^{(su(k), su(k))}$. The 4d theory is obtained by gauging the diagonal subgroup $SU(N)_{\text{diag}} \subset SU(N)_L \times SU(N)_R$ of the 4d $\mathcal{S}_{k,N}$. This can be easily done in the class S theory. We just need to replace $\mathbb{T}_N\{[1^N], [1^N], Y\}$ ($Y = [N-k, 1^k]$ or $[1^N]$) by the theory on a torus $S_N\langle T_\tau^2 \rangle\{Y\}$, where $S_N\langle T_\tau^2 \rangle\{Y\}$ means the class S theory of type A_{N-1} whose Gaiotto curve is a torus with modulus τ and a puncture labeled by Y . Therefore, the final result is

$$\mathcal{F}_{N-1}^{(su(k), su(k))} \xrightarrow{T^2} \begin{cases} S_N\langle T_\tau^2 \rangle\{[N-k, 1^k]\} - SU(k) - \mathbb{T}_k\{[1^k], [1^k], [1^k]\} & (N > k) \\ S_N\langle T_\tau^2 \rangle\{[1^N]\} - [SU(N) + \text{one fund.}] - \mathbb{T}_N\{[1^N], [1^N], [1^N]\} & (N = k) \\ S_N\langle T_\tau^2 \rangle\{[1^N]\} - SU(N) - \mathbb{T}_k\{[1^k], [1^k], [k-N, 1^N]\} & (N < k) \end{cases} \quad (3.3.28)$$

This theory has the $SL(2, \mathbb{Z})$ S-duality group acting on $S_N\langle T_\tau^2 \rangle\{[1^N]\}$, and has manifest $SU(k)_L \times SU(k)_R$ flavor symmetry from the two full punctures $[1^k]$.

To give further checks of the above proposal, we need a mass deformation of the theory $\mathbb{T}_N\{[1^N], [1^N], Y\}$. The following facts, which hold in both 4d and 5d versions of the theory $\mathbb{T}_N\{[1^N], [1^N], Y\}$, are known [92, 93].

Let us give generic masses to the diagonal subgroup of $SU(N)_L \times SU(N)_R$ of the full punctures. Then this theory flows in the IR to a linear quiver

$$\mathbb{T}_N\{[1^N], [1^N], Y\} \xrightarrow{SU(N)_{\text{diag}} \text{ mass deform}} SU(\nu_1) - SU(\nu_2) - \cdots - SU(\nu_{N-1}) \quad (3.3.29)$$

In this quiver, each gauge group is coupled to additional fundamentals if necessary so that each gauge group becomes conformal. The ν_i are determined as follows. The Y is specified by a partition of N as $Y = [m_1, m_2, \dots, m_\ell]$. This partition Y defines a Young diagram. Then we can consider the transpose of the Young diagram Y , which we denote as $Y^T = [n_1, \dots, n_k]$ where $n_1 \geq \dots \geq n_k$. We also define $n_i = 0$ for $i > k$. Then ν_i is determined by

$$\nu_{i-1} - \nu_i = 1 - n_i, \quad \nu_{N-1} = 1. \quad (3.3.30)$$

If Y is given by $Y = [N-k, 1^k]$ with $N > k$, then $Y^T = [k+1, 1^{N-k-1}]$ and hence $n_1 = k+1$, $n_i = 1$ for $2 \leq i \leq N-k$ and $n_i = 0$ for $i > N-k$. Then $\nu_i = k$ for $i \leq N-k$ and $\nu_i = N-i$ for $N-k \leq i \leq N-1$, and the quiver becomes

$$[SU(k)] - SU(k) - \cdots - SU(k) - SU(k) - \cdots - SU(1). \quad (3.3.31)$$

The $[SU(k)]$ is a flavor symmetry coming from the fundamentals coupled to the leftmost $SU(k)$. This $[SU(k)]$ is identified with the flavor symmetry of the puncture $Y = [N-k, 1^k]$. There are

$N - k$ $SU(k)$ gauge groups. Similarly, if $Y = [1^N]$ we get

$$[SU(N)] - SU(N - 1) - SU(N - 2) - \cdots - SU(1). \quad (3.3.32)$$

Now we can discuss mass deformation of ${}^{\text{4d}}\mathcal{S}_{k,N}$ in (3.3.27). Let us mass-deform the diagonal subgroup of $SU(N)_L \times SU(N)_R$ in (3.3.27). When $N \geq k$, by using (3.3.31) one can see that we precisely get the theory (3.3.25). Similarly, if we deform the $SU(k)_L \times SU(k)_R$ in (3.3.27), then by using (3.3.32) with N replaced by k , we precisely get the theory (3.3.26). This gives a strong check of our proposal (3.3.27). In particular, note that the IR free gauge group appearing in (3.3.27) becomes conformal after the mass deformation of either $SU(N)$ or $SU(k)$. The conformality of gauge groups after the deformation of $SU(N)$ was indeed shown in our general discussion of the previous section from the 6d point of view.

We have seen that (3.3.25) and (3.3.26) can be obtained by mass deformation of $SU(N)$ and $SU(k)$ in (3.3.27), respectively. By going back the duality, we can also get the 4d version of the right hand side of (3.3.21) and (3.3.22), respectively. In the compactification of $\mathcal{T}_{N-1}^{(\text{su}(k), \text{su}(k))}$, the diagonal subgroup of $SU(N)_L \times SU(N)_R$ is gauged. In this way, we get two theories; one is a linear $SU(k)^{N-1}$ quiver with the gauge coupling determined by the vev of $\Phi_{SU(N)}$, and the other is a necklace $SU(N)^k$ quiver. These are the theories discussed in [72]. Now we can see that these two theories flow from the single 4d theory (3.3.28) which has manifest $SL(2, \mathbb{Z})$ S-duality and $SU(k)_L \times SU(k)_R$ flavor symmetry.

3.3.2.2. M-theory interpretation

Here we try to understand (3.3.28) in terms of M5 branes in M-theory. As mentioned above, the A-type conformal matter is realized in M-theory by putting N coincident M5 branes on A_{k-1} singularity. If we realize this A_{k-1} singularity by Taub-NUT space and go to type IIA string theory, we get a system of N coincident NS5 branes and k coincident D6 branes intersecting with each other. The A-type conformal matter is realized on the intersection.

Now we compactify the theory on T^2 so that we get a T^2 compactification of the conformal matter. Taking T-dual twice, we get N coincident NS5 branes and k coincident D4 branes. Uplifting to M-theory, we get N coincident M5 branes and k coincident M5 branes intersecting on 4-dimensional subspace.

The directions in which M5 branes are extending after the above duality chain are listed in table 3.2. They are intersecting on the space $\mathbb{R}^{1,3}$. Furthermore, N M5 branes are compactified on T^2 , and k M5 branes are compactified on $S^1 \times \mathbb{R}$.

Let us focus on the N M5 branes. This is compactified on T^2 , so it is a class S theory of A_{N-1} type on T^2 . From the point of view of this N M5 branes, the k M5 branes look like a codimension 2 defect, and hence it is a kind of puncture. So it is natural to obtain a theory $S_N \langle T^2 \rangle \{Y\}$, where Y is specified by the k M5 branes. Next, let us focus on the k M5 branes. This is compactified on $S^1 \times \mathbb{R}$, but this space can be regarded as a sphere with two full punctures in class S theory. So this is a class S theory of type A_{k-1} on a Riemann sphere with two full punctures and one puncture Y' specified by the N M5 branes which look like a puncture from the point of view of the k M5 branes. Hence, we get the theory $T_k \{[1^k], [1^k], Y'\}$. These observations partly explain

	$\mathbb{R}^{1,3}$	T^2 (or $S^1 \times \mathbb{R}$)	$S^1 \times \mathbb{R}$	\mathbb{R}^3
N M5 branes	•	•		
k M5 branes	•		•	

Table 3.2.: Directions in which M5 branes extend.

the structure of (3.3.28). Conversely, our results tell us what exactly happens in this setup of M5 branes.

When $N = 1$, one M5 brane is a simple puncture from the point of view of the k M5 branes [94]. This was also found in minimal conformal matters of general ADE type [14]. Our result is consistent with this because in this case $[k - N, 1^N] = [k - 1, 1]$ is a simple puncture.

It is also clear that if we replace the T^2 of table 3.2 by $S^1 \times \mathbb{R}$, the theory we obtain from the M5 branes' intersection should be ${}^{\text{4d}}\mathcal{S}_{k,N}$ in (3.3.27). This is a little progress in the understanding of M-theory and $\mathcal{N}=(2,0)$ theory. In general, it is very interesting to study what happens when two bunches of M5 branes intersect with each other along 4-dimensional subspace. This is a difficult problem to answer if the M5 branes are intersecting in flat $\mathbb{R}^{1,10}$ space, because the $\mathcal{N}=(2,0)$ theory is intrinsically strongly coupled and hence there is no clear separation between the bulk $\mathcal{N}=(2,0)$ theory and the 4d theory living on the intersection. However, if we compactify the M5 branes on S^1 , we get 5d $\mathcal{N}=2$ super Yang-Mills which is weakly coupled in the IR limit. Then it becomes a well-defined question to ask what theory is living on the intersection. If we compactify the system on S^1 which is common to both N M5 branes and k M5 branes, the system is reduced to a well-known situation in which D4 branes are intersecting and we just get free hypermultiplets in 3d. Instead, if we compactify the system on two S^1 's as in table 3.2 with the replacement $T^2 \rightarrow S^1 \times \mathbb{R}$, the intersection looks like a codimension-one domain wall from the point of view of each of the 5d $\mathcal{N}=2$ super Yang-Mills theories. What we found is that the theory living on this domain wall is the 4d theory ${}^{\text{4d}}\mathcal{S}_{k,N}$ in (3.3.27). Flavor symmetries $SU(N)_L \times SU(N)_R$ and $SU(k)_L \times SU(k)_R$ are naturally coupled to the gauge groups of 5d $SU(N)$ and $SU(k)$ $\mathcal{N}=2$ super Yang-Mills theories on the two sides of the domain walls, respectively.

3.3.2.3. Nilpotent vev

It is obvious to generalize the above result to the case of $\mathcal{F}_{N-1}^{(\text{su}(k), \text{su}(k))} \{Y_L, Y_R\}$ introduced in Subsection 2.4.5. The tensor branch quiver is exposed in (2.4.30) for the case where Y_L is full $F = [1^k]$, and it is straightforward to generalize it for the case with general Y_L and Y_R as mentioned below the equation.

As already discussed in the general arguments of the previous section, the 5d version of the quiver (2.4.30) is expected to have a UV fixed point ${}^{\text{5d}}\mathcal{S}_{k,N} \{Y_L, Y_R\}$ with enhanced $SU(N)_L \times SU(N)_R$ symmetry. Then the S^1 compactification of $\mathcal{F}_{k,N}^{6d} \{Y_L, Y_R\}$ is given by this ${}^{\text{5d}}\mathcal{S}_{k,N} \{Y_L, Y_R\}$ with the diagonal subgroup of $SU(N)_L \times SU(N)_R$ gauged.

It is also easy to determine the 4d theory. We just need to higgs the moment maps μ_L and μ_R

of the theory (3.3.28) by nilpotent vev. The result is

$$\mathcal{T}_{N-1}^{(\mathfrak{su}(k), \mathfrak{su}(k))} \{Y_L, Y_R\} \xrightarrow{T^2} \begin{cases} \mathbb{S}_N \langle T_\tau^2 \rangle \{[N-k, 1^k]\} - \text{SU}(k) - \mathbb{T}_k \{[1^k], Y_L, Y_R\} & (N > k) \\ \mathbb{S}_N \langle T_\tau^2 \rangle \{[1^N]\} - [\text{SU}(N) + \text{one fund.}] - \mathbb{T}_N \{[1^N], Y_L, Y_R\} & (N = k) \\ \mathbb{S}_N \langle T_\tau^2 \rangle \{[1^N]\} - \text{SU}(N) - \mathbb{T}_k \{[k-N, 1^N], Y_L, Y_R\} & (N < k) \end{cases} \quad (3.3.33)$$

3.3.2.4. Cases without IR-free gauge group

There is actually a special subclass of theories in which the IR free gauge group does not appear. We take $k = N$ and $Y_L = [N]$ ($Y_L^T = [1^N]$). For simplicity, let us first consider the case $Y_R = [1^N]$ ($Y_R^T = [N]$). Then the 6d theory is given by

$$\begin{array}{cccc} \mathfrak{su}(N-1) & \cdots & \mathfrak{su}(2) & \mathfrak{su}(1) \\ 2 & \cdots & 2 & 2 \end{array} + \text{one fund. of flavor } \mathfrak{su}(N), \quad (3.3.34)$$

where additional free hypermultiplet can be seen from the type IIA construction. Such a non-interacting hypermultiplet charged under the remaining flavor symmetry exists for any Y_R , and we call the interacting part $\mathcal{T}_{N,N}^{6d} \{[N], Y_R\}_{\text{int}}$. In the 4d theory, one of the punctures Y_L is completely higgsed and this puncture disappears. It is called the closing of the puncture. After this, we get a theory $\mathbb{T}_N[[1^N], [1^N]]$ with two full punctures, or equivalently a theory on a tube (with Dirichlet boundary conditions at the two ends when the $\mathcal{N}=(2,0)$ theory is reduced to 5d $\mathcal{N}=2$ super Yang-Mills). This theory is actually not an interacting SCFT. The $\text{SU}(N) \times \text{SU}(N)$ symmetries associated to the full punctures are automatically broken down to the diagonal subgroup [95]. Then, when the $\text{SU}(N)$ is gauged, the gauge group is completely higgsed by this theory $\mathbb{T}_N[[1^N], [1^N]]$ and only the flavor $\text{SU}(N)_R$ survives by mixing with the gauge group. By applying these facts to (3.3.33), we get

$$\mathcal{T}_{N,N}^{6d} \{[N], [1^N]\} \xrightarrow{T^2} \mathbb{S}_N \langle T_\tau^2 \rangle \{[1^N]\} + \text{one fund.} \quad (3.3.35)$$

Here, one can check that there are N free decoupled hypermultiplets in 4d after the process of nilpotent higgsing as can be checked by the method of [96], and these decoupled hypermultiplets are identified with the additional hypermultiplets in (3.3.33) in the fundamental representation of $\text{SU}(N)$ which is higgsed. Subtracting the hypermultiplets from both side, we get

$$\begin{array}{cccc} \mathfrak{su}(N-1) & \cdots & \mathfrak{su}(2) & \mathfrak{su}(1) \\ 2 & \cdots & 2 & 2 \end{array} \xrightarrow[\text{point}]{\text{conformal}} \mathcal{T}_{N,N}^{6d} \{[N], [1^N]\}_{\text{int}} \xrightarrow{T^2} \mathbb{S}_N \langle T_\tau^2 \rangle \{[1^N]\}. \quad (3.3.36)$$

In the same way, we can also consider general $Y_R := Y$. The interacting part of the 6d theory is

$$\begin{array}{cccc} \mathfrak{su}(v_1) & \cdots & \mathfrak{su}(v_{N-1}) \\ 2 & \cdots & 2 \end{array} \quad (3.3.37)$$

where v_i are defined by (3.3.30). Note that $v_{N-1} = 1$. We can simply partially close $[1^N]$ in the

above equation to obtain

$$\begin{array}{ccc} \mathfrak{su}(\nu_1) & \cdots & \mathfrak{su}(\nu_{N-1}) \\ 2 & \cdots & 2 \end{array} \xrightarrow[\text{point}]{\text{conformal}} \mathcal{T}_{N,N}^{6d} \{[N], Y\}_{\text{int}} \xrightarrow{T^2} S_N \langle T_\tau^2 \rangle \{Y\} \quad (3.3.38)$$

for arbitrary Y . In this class of theories, the corresponding 4d theory is conformal without any IR free gauge group.

We can also derive the above results much more directly. As already described in Sec. 3.3.2.1, the 5d version of the quiver (3.3.37) has a fixed point which is a 5d version of the T_N -like theory, $T_N^{5d} \{[1^N], [1^N], Y\}$. Thus, in our notation above, we find that ${}^{5d}\mathcal{S}_{N,N} \{[N], Y\} = T_N^{5d} \{[1^N], [1^N], Y\}$. The S^1 compactification of $\mathcal{T}_{N,N}^{6d} \{[N], Y\}_{\text{int}}$ is thus the $T_N^{5d} \{[1^N], [1^N], Y\}$ theory with the diagonal subgroup of $SU(N)_L \times SU(N)_R$ coming from the full punctures gauged. By reducing this theory further to 4d, we immediately get (3.3.38).

3.3.3. Conformal matters and class S theories, general type

Next, let us discuss the 6d theory $\mathcal{T}_{N-1}^{(\mathfrak{g}, \mathfrak{g})}$ on the worldvolume of N M5-branes on $\mathbb{C}^2/\Gamma_{\mathfrak{g}}$ singularity, where \mathfrak{g} can be D_k or E_k . The author have not been able to obtain as full an answer for $\mathfrak{g} = E_k$ case, as in the case of $\mathfrak{g} = A_{k-1}$, but we can still understand quite a lot¹⁸. Also, even for $\mathfrak{g} = A_{k-1}$, the analysis in this section sheds some new light.

3.3.3.1. Structure of the 5d reduction

On the tensor branch in 6d, the quiver is of the form

$$\begin{array}{ccccc} [\mathfrak{g}] & \mathfrak{g} & \cdots & \mathfrak{g} & [\mathfrak{g}] \\ & 2 & \cdots & 2 & \end{array} \quad (3.3.39)$$

where the bifundamental ‘matter’ of $\mathfrak{g} \times \mathfrak{g}$ is a nontrivial 6d very-higgsable SCFT.

First let us compactify on S^1 without any Wilson line. From our general discussion, its S^1 compactification is given by a 5d $SU(N)$ gauge theory coupled to a strongly-coupled SCFT ${}^{5d}\mathcal{S} \{ \mathfrak{g}, \mathfrak{g}, SU(N) \}$, which is the strongly-coupled SCFT limit of the 5d quiver

$$[\mathfrak{g}_L] - \mathfrak{g} - \cdots - \mathfrak{g} - [\mathfrak{g}_R], \quad (3.3.40)$$

where bifundamentals are nontrivial 5d conformal theories. To the knowledge of the authors, no study has been done on such quivers with generalized matters in 5d, but our general discussion in Sec 3.3.1 requires that there is an enhancement of the flavor symmetry of (3.3.40) from $U(1)^{N-1}$ instanton symmetries to $SU(N)$, just as in the case when \mathfrak{g} is of type A where the matter fields are free bifundamental hypermultiplets.

The same 5d SCFT ${}^{5d}\mathcal{S} \{ \mathfrak{g}, \mathfrak{g}, SU(N) \}$ can be identified as follows. If we instead compactify the 6d theory on S^1 with generic Wilson lines in the diagonal subgroup of the flavor symmetry $\mathfrak{g}_L \times \mathfrak{g}_R$, we get a 5d ordinary quiver theory whose nodes form the affine Dynkin diagram of type

¹⁸The full answer for $\mathfrak{g} = D_k$ case was obtained after publishing [16], and appears nowhere in the literature.

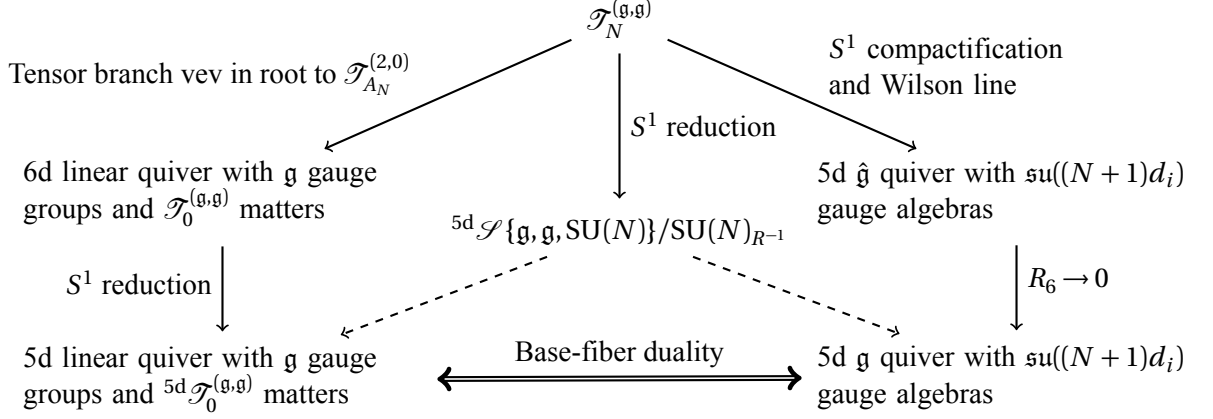

Figure 3.13.: Relation between $\mathcal{T}_N^{(g,g)}$ and 6d and 5d gauge theories. After taking $R_6 \rightarrow 0$ limit and decoupling the 5d $G = \text{SU}(N)$ vector, Wilson line and tensor vev becomes different mass deformations (denoted by dashed lines) of the 5d SCFT ${}^{5d}\mathcal{T}_N^{(g,g)}$, and this relation is nothing but the base-fiber duality when $g = A$.

g as seen in Subsection 2.4.4. The gauge group is

$$\prod_{a=0}^{\text{rank } g} \text{SU}(d_a N) \quad (3.3.41)$$

where $d_0 = 1$ corresponds to the affine node and the vector (d_a) is in the kernel of the affine Cartan matrix. There is as always the bifundamental matter fields for the edges of the Dynkin diagram. The $\text{SU}(N)$ at the extended node is our G vector multiplet of the general discussion.

In summary, we have two theories. One is the theory (3.3.40) and the other is the theory

$$\text{finite Dynkin quiver of type } g \text{ with the gauge group } \prod_{a=1}^{\text{rank } g} \text{SU}(d_a N). \quad (3.3.42)$$

These theories (3.3.40) and (3.3.42) should have a common UV fixed point $\mathcal{S}^{5d}\{g, g, \text{SU}(N)\}$, with the flavor symmetry $g_L \times g_R \times \text{SU}(N)$. Only $g_L \times g_R$ is manifest in (3.3.40), which is obtained by mass deformation in $\text{SU}(N)$ of $\mathcal{S}^{5d}\{g, g, \text{SU}(N)\}$, while only $\text{SU}(N)$ is manifest in (3.3.42) which is obtained by mass deformation in the diagonal subgroup of $g_L \times g_R$. In this sense, these two IR theories (3.3.40) and (3.3.42) are dual to each other. This is the precise version of the “novel 5d duality” of [13]. The case of $N = 1$ and $g = D_n$ was studied explicitly in [14].

Summarizing, the compactification on S^1 of the 6d theory $\mathcal{T}_N^{6d}\{g, g\}$ has the structure shown in Fig. 3.13. The 5d theory becomes a generalized quiver on the part of the 5d Coulomb branch that corresponds to the 6d tensor branch, and becomes a standard affine quiver when mass deformed.

3.3.3.2. Structure of the 4d reduction

Now let us compactify one further dimension and identify ${}^{4d}\mathcal{S}\{\mathfrak{g}, \mathfrak{g}, \text{SU}(N)\}$. The question can be approached either from the point of view of the theory (3.3.40) or (3.3.42). Here we choose to use (3.3.40).

The deformation of ${}^{4d}\mathcal{S}\{\mathfrak{g}, \mathfrak{g}, \text{SU}(N)\}$ by the mass parameter for $\text{SU}(N)$ is the 4d quiver

$$[\mathfrak{g}_L] - \mathfrak{g} - \cdots - \mathfrak{g} - [\mathfrak{g}_R]. \quad (3.3.43)$$

where the generalized bifundamental $B_{\mathfrak{g}}$ of $\mathfrak{g} \times \mathfrak{g}$ comes from the T^2 reduction of the very higgsable SCFT in 6d. As studied Section 3.1, this generalized bifundamental is given by a class S theory $B_{\mathfrak{g}} := T_{\mathfrak{g}}\{\mathfrak{g}, Y_{\text{simple}}, \mathfrak{g}\}$, i.e. the class S theory of type \mathfrak{g} on a sphere with two full punctures and a simple puncture. Therefore, the quiver (3.3.43) theory itself is a class S theory of type \mathfrak{g} on a sphere with two full punctures and N simple punctures, which we denote as

$$T_{\mathfrak{g}}\{F, S, \dots, S, F\}, \quad (3.3.44)$$

where F, S denote full and simple punctures. The $N - 1$ cross ratios are the IR remnant of the mass parameters of the $\text{SU}(N)$ flavor symmetry ${}^{4d}\mathcal{S}\{\mathfrak{g}, \mathfrak{g}, \text{SU}(N)\}$.

$$T_{\mathfrak{g}}\{S, \dots, S, F, F\}, \quad (3.3.45)$$

meaning the simple punctures are near to each other while the two full punctures are apart from them. In Sec. 3.3.3.3 below, we will determine the resulting quiver for $\mathfrak{g} = A_{k-1}, D_k, E_6$ using the known data, and we will find that the outcome has the form, when N is sufficiently large,

$$\text{a 4d generalized quiver} - \mathfrak{g} - T_{\mathfrak{g}} \quad (3.3.46)$$

where the 4d quiver part on the left turns out to be exactly the T^2 reduction of the quiver theory of the 6d conformal matter with a full-closing: $\mathcal{T}_{N-1}^{(\mathfrak{g}, \mathfrak{g})}\{C, F\}$.

Let us denote the 6d theory as $\mathcal{T}_{N-1}^{(\mathfrak{g}, \emptyset)}$ for short. Its T^2 reduction is, from the general discussion in Sec. 3.3.1, given by a 4d theory ${}^{4d}\mathcal{T}_{N-1}^{(\mathfrak{g}, \emptyset)}\{\text{SU}(N), \mathfrak{g}\}$ whose $\text{SU}(N)$ flavor symmetry is gauged by an $\text{SU}(N)$ multiplet with $\text{SL}(2, \mathbb{Z})$ duality symmetry.

Therefore, we conclude that the T^2 compactification of the theory $\mathcal{T}_{N-1}^{(\mathfrak{g}, \mathfrak{g})}$, i.e. the theory on N M5-branes probing the $\mathbb{C}^2/\Gamma_{\mathfrak{g}}$ singularity, has the structure

$${}^{4d}\mathcal{T}_{N-1}^{(\mathfrak{g}, \mathfrak{g})} = \frac{{}^{4d}\mathcal{T}_{N-1}^{(\mathfrak{g}, \emptyset)}\{\text{SU}(N), \mathfrak{g}_T\} \times T_{\mathfrak{g}}\{\mathfrak{g}_B, \mathfrak{g}_L, \mathfrak{g}_R\}}{\text{SU}(N)_{\tau} \times (\text{diag. of } \mathfrak{g}_T \times \mathfrak{g}_B)} \quad (3.3.47)$$

where $\text{SU}(N)$ is conformal, when N is sufficiently large.¹⁹ For smaller N , one of the punctures and its symmetry \mathfrak{g}_B of the second factor $T_{\mathfrak{g}}$ become smaller.

For $\mathfrak{g} = \mathfrak{su}(k)$ case, the first component ${}^{4d}\mathcal{T}_{N-1}^{(\mathfrak{su}(k), \emptyset)}$ was conformal and the $\mathfrak{g} = \mathfrak{su}(k)$ gauge group was IR-free. In Subsection 3.3.3.4 we will see these properties also holds for $\mathfrak{g} = D_k$, and

¹⁹Note that we have $\mathfrak{g}_T = \mathfrak{g}_B = \mathfrak{g}_L = \mathfrak{g}_R = \mathfrak{g}$ here. The subscripts are there to distinguish various factors.

therefore we expect this structure of the 4d theory

$${}^{4d}\mathcal{S}\{G\} = \frac{({}^{4d}\mathcal{U}\{G, H\} \times {}^{4d}\mathcal{V}\{H\})}{G_\tau \times H_{\text{IRF}}} \quad (3.3.48)$$

with ${}^{4d}\mathcal{U}$, ${}^{4d}\mathcal{V}$ both being 4d SCFTs and H_{IRF} being a IR-free gauge multiplet is universal for any 6d theory \mathcal{T} higgsable to $\mathcal{T}_G^{(2,0)}$. Actually, in the paper [16] it is shown for $G = A, D$ case, though the proof is not contained in this thesis. The paper [16] also provides the way of calculating the 4d central charges of $\mathcal{T}_{N-1}^{(\mathfrak{g}, \emptyset)}$ from the 6d anomaly polynomial which is similar recursive calculation we did in Subsection 3.1.1, though much complicated.

3.3.3.3. Detailed class S analysis

Now what is left is to present a class S analysis for the (3.3.45) for $\mathfrak{g} = A_{k-1}, D_k$, and E_6 .

When $\mathfrak{g} = A_{k-1}$, the resulting quiver is

$$\mathfrak{su}(1) - \mathfrak{su}(2) - \mathfrak{su}(3) - \cdots - \mathfrak{su}(k-1) - \mathfrak{su}(k) - \mathfrak{su}(k) - \cdots - \mathbb{T}_k \quad (3.3.49)$$

where we have bifundamentals between neighboring groups and one additional fundamental at the leftmost $\mathfrak{su}(k)$, as by now well-known and originally derived in [6]. This is indeed the T^2 reduction of the $(\emptyset, \mathfrak{su}(k))$ matter, see (6.5) of [13].

When $\mathfrak{g} = D_k$, the resulting quiver can be found by the data compiled in [97]. We find

$$\mathfrak{su}(1) - \mathfrak{usp}(2) - \mathfrak{g}_2 - \mathfrak{so}(9) - \mathfrak{so}(11) - \cdots - \mathfrak{so}(2k-1) - \mathfrak{so}(2k) - \mathfrak{so}(2k) - \cdots - \mathbb{T}_{D_k} \quad (3.3.50)$$

where the matters are, from the left,

- a half-hyper in the doublet,
- a half-hyper in $\mathbf{2} \otimes \mathbf{7}$,
- the E_8 Minahan-Nemeschansky theory whose $\mathfrak{g}_2 \times \mathfrak{so}(9) \subset \mathfrak{g}_2 \times \mathfrak{f}_4 \subset \mathfrak{e}_8$ is gauged,
- the D_5 generalized bifundamental B_{D_5} whose $\mathfrak{so}(9) \times \mathfrak{so}(11) \subset \mathfrak{so}(20)$ symmetry is gauged,
...
- the D_k generalized bifundamental B_{D_k} whose $\mathfrak{so}(2k-1) \times \mathfrak{so}(2k)$ symmetry is gauged, etc.

This is indeed the T^2 reduction of the $(\emptyset, \mathfrak{so}(2k))$ matter, see the un-numbered equation at the top of p. 34 of [13]. Note that the theory $B_{D_k} = \mathbb{T}_{D_k}\{\mathfrak{so}(2k), \mathfrak{so}(2k), Y_{\text{simple}}\}$ has an enhanced flavor symmetry $\mathfrak{so}(4k)$ compared to what is apparent in the class S description, and its subgroup $\mathfrak{so}(2k-1) \times \mathfrak{so}(2k+1)$ is gauged in this construction.

When $\mathfrak{g} = E_6$, the resulting quiver can be found by the data compiled in [98]: we find

$$\mathfrak{su}(1) - \mathfrak{usp}(2) - \mathfrak{g}_2 - \mathfrak{f}_4 - \mathfrak{e}_6 - \mathfrak{e}_6 \cdots \cdots - \mathbb{T}_{E_6} \quad (3.3.51)$$

where the matters are, from the left,

- a half-hyper in the doublet,
- a half-hyper in $\mathbf{2} \otimes \mathbf{7}$,
- the E_8 Minahan-Nemeschansky theory whose $\mathfrak{g}_2 \times \mathfrak{f}_4 \subset \mathfrak{e}_8$ is gauged,
- the E_6 generalized bifundamental B_{E_6} whose $\mathfrak{f}_4 \times \mathfrak{e}_6$ symmetry is gauged.

This is indeed the T^2 reduction of the $(\emptyset, \mathfrak{e}_6)$ matter, see (6.7) of [13].

When $\mathfrak{g} = E_7$ and E_8 , the class S data for $\mathfrak{g} = E_7$ and E_8 are not yet available. Nonetheless, we consider the agreement we found so far is convincing enough that this correspondence works for all \mathfrak{g} . This can also be considered as a prediction for the repeated collision of the simple punctures in the class S theory of type E_7 and E_8 . From the structure of $(\emptyset, E_{n=7,8})$ conformal matters given in (6.8) and (6.9), our prediction is that the class S theories of type $E_{n=7,8}$ with multiple simple punctures and two full punctures have a duality frame of the form

$$\mathfrak{su}(1) - \mathfrak{usp}(2) - \mathfrak{g}_2 - \mathfrak{f}_4 - \mathfrak{e}_n - \mathfrak{e}_n \cdots \cdots - \mathbb{T}_{E_n} \quad (3.3.52)$$

where the matters are, from the left,

- a half-hyper in the doublet,
- a half-hyper in $\mathbf{2} \otimes \mathbf{7}$,
- the E_8 Minahan-Nemeschansky theory whose $\mathfrak{g}_2 \times \mathfrak{f}_4 \subset \mathfrak{e}_8$ is gauged,
- a certain SCFT with $E_4 \times E_n$ flavor symmetry, which comes from the 6d very higgsable theory with the structure

$$\begin{array}{ccccccc} [\mathfrak{f}_4] & \mathfrak{g}_2 & \mathfrak{su}_2 & & [\mathfrak{e}_7] & & \\ 1 & 3 & 2 & 1 & & & \\ & & & & \text{for } E_7, & & \end{array} \quad \begin{array}{ccccccc} [\mathfrak{f}_4] & \mathfrak{g}_2 & \mathfrak{sp}_1 & & & & [\mathfrak{e}_8] \\ 1 & 3 & 2 & 2 & 1 & & \\ & & & & & & \text{for } E_8, \end{array} \quad (3.3.53)$$

- and the E_n generalized bifundamentals B_{E_n} which is the class S theory on a sphere with two full punctures and a simple puncture.

3.3.3.4. Determining the 4d theory for $\mathfrak{g} = D_k$

Here, as a final part of the body of this thesis, we determine the 4d theory ${}^{4d}\mathcal{T}_{N-1}^{(\mathfrak{g}, \mathfrak{g})}$ for $\mathfrak{g} = D_k$. To do this, we remind ourselves that when S^1 compactified with Wilson lines the theory becomes the

5d D_k -shaped Dynkin quiver

$$\begin{array}{ccccccc} \text{SU}(N) & - & \text{SU}(2N) & - & \cdots & - & \text{SU}(2N) & - & \text{SU}(N) \\ & & | & & & & | & & \\ & & [\text{SU}(N)] & & & & \text{SU}(N) & & \end{array} . \quad (3.3.54)$$

The point is that the 4d version of this quiver admits a class S construction with \mathbb{Z}_2 twisted punctures²⁰ [99]:

$$\mathbb{T}_{2N}\{[2^N], S, \cdots, S, \underline{TM}, \underline{TM}\} \quad (3.3.55)$$

where \underline{TM} is the twisted minimal puncture and the number of simple punctures S is k . We denote a twisted puncture with a symbol dressed by an underline. Tuning the couplings of the SU gauge groups to be strong corresponds to pushing simple punctures S towards one of \underline{TM} . The resulting configuration is

$$\text{a 4d (generalized) quiver} - \mathbb{T}_{2N}\{\underline{\mathcal{O}}_k, [2^N], \underline{TM}\} \quad (3.3.56)$$

where $\underline{\mathcal{O}}_k$ is the twisted puncture obtained by colliding k simple punctures S and one twisted minimal puncture \underline{TM} ²¹. When $k \geq N \geq 3$, $\underline{\mathcal{O}}_k$ is the twisted full puncture \underline{TF} which have a $\text{SO}(2N+1)$ symmetry.

Therefore, we can identify the ${}^{4d}\mathcal{F}_{N-1}^{(\mathfrak{g}, \emptyset)}$ in (3.3.47) with $\mathbb{T}_{2N}\{\underline{\mathcal{O}}_k, [2^N], \underline{TM}\}$:

$${}^{4d}\mathcal{F}_{N-1}^{(\mathfrak{g}, \mathfrak{g})} = \frac{\mathbb{T}_{2N}\{\underline{\mathcal{O}}_k, [2^N], \underline{TM}\} \times \mathbb{T}_{\mathfrak{g}}\{\mathfrak{g}_B, \mathfrak{g}_L, \mathfrak{g}_R\}}{\text{SU}(N)_\tau \times (\text{diag. of } \mathfrak{g}_T \times \mathfrak{g}_B)}, \quad (3.3.57)$$

where \mathfrak{g}_T is the symmetry of $\underline{\mathcal{O}}_k$ and $(\text{diag. of } \mathfrak{g}_T \times \mathfrak{g}_B)$ means the diagonal of maximal common subgroups of the two algebras. The superconformal $\text{SU}(N)_\tau$ gauge field can be absorbed into the twisted class S theory and giving

$${}^{4d}\mathcal{F}_{N-1}^{(\mathfrak{g}, \mathfrak{g})} = \frac{\mathbb{T}_{2N}\{\underline{\mathcal{O}}_k, \underline{TM}, \underline{TM}, \underline{TM}\} \times \mathbb{T}_{\mathfrak{g}}\{\mathfrak{g}_B, \mathfrak{g}_L, \mathfrak{g}_R\}}{(\text{diag. of } \mathfrak{g}_T \times \mathfrak{g}_B)}. \quad (3.3.58)$$

The torus modulus τ becomes the cross ratio of four twisted punctures of the class S theory $\mathbb{T}_{2N}\{\underline{\mathcal{O}}_k, \underline{TM}^3\}$.

²⁰A puncture of class S of type G theory can be twisted by a nontrivial outer-automorphism of G .

²¹When $N = 2$, since the puncture given by colliding $[2, 2]$ and \underline{TM} is $[\underline{2}^2, 1]$ in the notation of [99] which is smaller than the twisted full puncture \underline{TF} , $\underline{\mathcal{O}}_k = [\underline{2}^2, 1]$. When $N \geq 3$ the puncture arising from $[2, 2]$ and \underline{TM} is the twisted full puncture \underline{TF} , so the statement of the main text is correct.

4. Conclusion

4.1. Recapitulation and summary

As a conclusion, we would like to summarize what we have seen.

In Chapter 3, we investigated torus compactifications of 6d SCFTs which are very-higgsable, or higgsable to $\mathcal{N}=(2,0)$. When the considered 6d theory \mathcal{T} is an $\mathcal{N}=(2,0)$ theory $\mathcal{T}_G^{(2,0)}$, the 4d theory ${}^{4d}\mathcal{T}$ is (in IR) the 4d $\mathcal{N}=4$ SYM, and important properties are

1. ${}^{4d}\mathcal{T}$ (which is $\mathcal{N}=4$ SYM) is conformal (and coupled), and
2. the modulus τ of compactifying torus is the marginal coupling of ${}^{4d}\mathcal{T}$.

We wanted to know these properties were common in 6d SCFTs. We found that

1. is true but 2. is false for very-Higgsable theories, and 1. is false in general for higgsable to $\mathcal{N}=(2,0)$ theories.

In section 3.2, the 4d theories are identified with class S theories without a marginal deformation for a large class of very-higgsable theories

However, we also observe that

When the endpoint tensor branch quiver contains a tensor mode (a^k, B^k) which is not coupled with any vector field by the coupling $a^k \text{Tr} F \wedge \star F$, then the torus compactified theory ${}^{4d}\mathcal{T}$ satisfies both above properties 1. and 2.

When the 6d theory is $\mathcal{T}_{N-1}^{(\text{su}(k), \text{su}(k))} \{C, F\}$, whose tensor branch quiver is

$$\begin{array}{ccccccc} \text{su}(1) & \text{su}(2) & \cdots & \text{su}(k) & \cdots & \text{su}(k) & [\text{su}(k)] \\ 2 & 2 & \cdots & 2 & \cdots & 2 & \end{array}, \quad (4.1.1)$$

the 4d theory is a class S theory:

$${}^{4d}\mathcal{T}_{N-1}^{(\text{su}(k), \emptyset)} = \frac{\mathbb{T}_N \{F, F, F\}}{\text{SU}(N)_\tau} = \text{S}_N \langle T_\tau^2 \rangle \{F\}. \quad (4.1.2)$$

In summary, torus compactifications of 6d SCFTs do not always satisfies the conditions 1. and 2. posed above, and the behavior under the torus compactifications is more-or-less characterized by the 6d fixed point of the flow triggered by a generic Higgs vev.

4.2. Future directions

As emphasized in Chapter 1, our motivation to study compactifications of 6d theories is to generalize the story of class S theory [6] to less supersymmetric situation. To this objective, considering putting $\mathcal{T}_{N-1}^{(\mathfrak{su}(k), \emptyset)}$ on a general Riemann surface might look attracting. Nevertheless, the torus compactified theory (4.1.2) is already non-Lagrangian, therefore it is hard to naively generalize the analysis of class S theory to this case.

There is another way found by Gaiotto himself and his collaborator: [60]. Consider an (A, A) conformal matter, and introduce Wilson lines in terms of the diagonal of flavor groups $\mathfrak{su}(k)^{\oplus 2}$ breaking them down to $\mathfrak{u}(1)^{\oplus (2k-2)}$. Then the torus compactified theory is the affine quiver as we reviewed, and therefore that compactification satisfies above properties 1. and 2. Putting on a general Riemann surface with generic $\mathfrak{su}(k)$ flat bundle, the theory is expected to define a 4d $\mathcal{N}=1$ theory. Pursuing this direction [62, 100] is definitely interesting. In addition, what happens when the $\mathfrak{su}(k)$ flat bundle tuned to be trivial might also be interesting, from the point of view of this thesis.

In this thesis we focus on compactifications of subclasses of 6d SCFTs. Others, including $\mathcal{T}_{N-1}^{(\mathfrak{usp}(2k), \mathfrak{usp}(2k))}$ case should also be studied. Some cases are already investigated in [72] using the mirror symmetry technique, and recast their result into the language we have been using might be helpful.

Aside from issues of compactifications, it is also intriguing to study 6d theories itself, in particular as a probe of M-theory. We saw some intricate M-theory physics is encoded in the consistency conditions of 6d SCFTs. There should be other facts about M-theory which can be observed from relationships between M-theory and 6d SCFTs like the unknown map (2.5.8).

Acknowledgement

The author would like to express his most his deepest gratitude to his (virtual) advisor Prof. Yuji Tachikawa, for encouraging him with patience, introducing to me the subject of 6d SCFTs, and everyday frank discussions¹. The author cannot come alone where he is standing, and who mainly have been pulling him up was Tachikawa-san. The time he spent with Tachikawa-san chatting about physics, or something else, was precious.

Next, the author thanks to Kazuya Yonekura and Hiroyuki Shimizu, who were collaborators of the works which is used in this thesis. Without their brilliant insights, the works could not come out. He is also grateful to wonderful people in the theoretical particle physics group, in particular Prof. Yutaka Matsuo, who is the author's official advisor for allowing him to joint the distinguished group and giving him various precious advises.

Last but not the least, the author must express his gratitude to his parents and his fiancée for giving me continuous and encouraging support throughout his years of study, research and writing this thesis. All the author's works including this thesis cannot be accomplished without their cheerful assistance.

¹In addition, correcting the author's poor English.

A. Group theory constants and notations

In this Appendix we summarize the anomaly polynomials for multiplets of 6d $\mathcal{N}=(1,0)$ supersymmetry, and other group theoretic notations. In this paper we do not concern about subtleties arise from global structures of gauge groups and be careless about whether we are talking about groups or algebras.

In this paper we use the notation in which the anomaly polynomials of Weyl fermions in a representation ρ becomes

$$\hat{A}(T)\text{tr}_\rho e^{iF}. \quad (\text{A.0.1})$$

where $\hat{A}(T)$ is the A-roof genus. In particular, F is anti-Hermitican and include a $(2\pi)^{-1}$ factor in its definition compared to the usual one. The anomaly polynomials for $\mathcal{N}=(1,0)$ multiplets are the following:

- Hypermultiplet with representation ρ

$$I[\rho \text{ hyper}] = \frac{\text{tr}_\rho F^4}{24} + \frac{\text{tr}_\rho F^2 p_1(T)}{48} + d_\rho \frac{7p_1^2(T) - 4p_2(T)}{5760} \quad (\text{A.0.2})$$

- Vector multiplet with group G

$$I[G \text{ vector}] = -\frac{\text{tr}_{\text{adj}} F^4 + 6c_2(R)\text{tr}_{\text{adj}} F^2 + d_G c_2(R)^2}{24} - \frac{(\text{tr}_{\text{adj}} F^2 + d_G c_2(R))p_1(T)}{48} - d_G \frac{7p_1^2(T) - 4p_2(T)}{5760}$$

- Tensor multiplet

$$I[\text{tensor}] = \frac{c_2(R)^2}{24} + \frac{c_2(R)p_1(T)}{48} + \frac{23p_1(T)^2 - 116p_2(T)}{5760} \quad (\text{A.0.3})$$

where d_ρ and d_G are the dimensions of representation ρ and group G , respectively.

It is convenient to define the symbol Tr_G to be the trace in the adjoint representation divided by the dual Coxeter number h_G^\vee of the gauge group G , listed in Table A.1. One of the properties of Tr is that $\frac{1}{4} \int \text{Tr} F^2$ is one when there is one instanton on a four-manifold. Moreover, if we have subgroup G' in a group G with Dynkin index of embedding 1, for an element f of universal enveloping algebra of Lie algebra of G' , the following equation holds:

$$\text{Tr}_{G'} f = \text{Tr}_G f. \quad (\text{A.0.4})$$

G	$SU(k)$	$SO(k)$	$USp(2k)$	G_2	F_4	E_6	E_7	E_8
r_G	$k-1$	$\lfloor k/2 \rfloor$	k	2	4	6	7	8
h_G^\vee	k	$k-2$	$k+1$	4	9	12	18	30
d_G	k^2-1	$k(k-1)/2$	$k(2k+1)$	14	52	78	133	248
d_{fund}	k	k	$2k$	7	26	27	56	248
s_G	$\frac{1}{2}$	1	$\frac{1}{2}$	1	3	3	6	30
t_G	$2k$	$k-8$	$2k+8$	0	0	0	0	0
u_G	2	4	1	$\frac{10}{3}$	5	6	8	12

Table A.1.: Group theoretical constants defined for all G . Those constants are also listed in Appendix of [101].

G	$SU(2)$	$SU(3)$	G_2	F_4	E_6	E_7	E_8
w_G	$\frac{8}{3}$	3	$\frac{10}{3}$	5	6	8	12
x_G	$\frac{1}{6}$	$\frac{1}{6}$	$\frac{1}{3}$	1	1	2	12

Table A.2.: Group theoretical constants defined only for G without independent quartic Casimir.

All the embeddings we consider in this paper have the embedding index 1, so we always omit the subscription G in Tr_G . Further, we define a characteristic class $c_2(F)$ by

$$c_2(F) = \frac{1}{4} \text{Tr} F^2, \quad (\text{A.0.5})$$

which is the second Chern class when the gauge group of the considered bundle is SU .

To convert the above anomaly polynomials to a convenient form, we define some constants and write those values in Table A.1. We define the constant s_G which relates the trace of F^2 in the fundamental representation ¹ and $\text{Tr} F^2$ as $\text{tr}_{\text{fund}} F^2 = s_G \text{Tr} F^2$. Then we have

$$\text{tr}_{\text{adj}} F^2 = h_G^\vee \text{Tr} F^2 = 4h^\vee c_2(F), \quad \text{tr}_{\text{fund}} F^2 = 4s_G c_2(F), \quad (\text{A.0.6})$$

where the first equation is just the definition of Tr . For trace of F^4 , we define t_G and u_G by

$$\text{tr}_{\text{adj}} F^4 = t_G \text{tr}_{\text{fund}} F^4 + 12u_G c_2(F)^2 \quad (\text{A.0.7})$$

For gauge groups $G = SU(2), SU(3)$ and all exceptional groups, there are no independent quartic Casimir operators, so we can relate $\text{tr}_\rho F^4$ and $(\text{Tr} F^2)^2$ by

$$\text{tr}_{\text{adj}} F^4 = 12w_G c_2(F)^2, \quad \text{tr}_{\text{fund}} F^4 = 12x_G c_2(F)^2 \quad (\text{A.0.8})$$

These constants are tabulated in Table A.2. Note that because $t_{SO(8)} = 0$, we can also relate $\text{tr}_{\text{adj}} F^4$ to $(\text{Tr} F^2)^2$ for $G = SO(8)$.

All representations we use in this paper are fundamental or adjoint, except for the spin repre-

¹Here, fundamental representation mean the defining representation for classical groups, and **7, 26, 27, 56** and **248** for G_2, F_4, E_6, E_7 and E_8 , respectively.

sentation **8** of $\text{SO}(7)$. The conversion constant for this representation is

$$\begin{aligned}\text{tr}_8 F^2 &= \text{Tr } F^2 = 4c_2(F), \\ \text{tr}_8 F^4 &= -\frac{1}{2}\text{tr}_{\text{fund}} F^4 + 6c_2(F)^2.\end{aligned}\tag{A.0.9}$$

Finally, let us note that the finite subgroup Γ_G of $\text{SU}(2)$ of type $G = A_n, D_n$ and E_n has the following order:

$$|\Gamma_{\text{SU}(k)}| = k, \quad |\Gamma_{\text{SO}(2k)}| = 4k - 8, \quad |\Gamma_{E_6}| = 24, \quad |\Gamma_{E_7}| = 48, \quad |\Gamma_{E_8}| = 120.\tag{A.0.10}$$

Bibliography

- [1] E. Witten, “Some comments on string dynamics,” in *Future perspectives in string theory. Proceedings, Conference, Strings’95, Los Angeles, USA, March 13-18, 1995*. 1995. arXiv:hep-th/9507121 [hep-th].
- [2] A. Strominger, “Open p-branes,” *Phys. Lett.* **B383** (1996) 44–47, arXiv:hep-th/9512059 [hep-th].
- [3] J. Polchinski, *String theory. Vol. 2: Superstring theory and beyond*. Cambridge University Press, 2007.
- [4] K. Ohmori, H. Shimizu, Y. Tachikawa, and K. Yonekura, “Anomaly polynomial of general 6d SCFTs,” *PTEP* **2014** no. 10, (2014) 103B07, arXiv:1408.5572 [hep-th].
- [5] W. Nahm, “Supersymmetries and their Representations,” *Nucl. Phys.* **B135** (1978) 149.
- [6] D. Gaiotto, “ $N = 2$ dualities,” *JHEP* **08** (2012) 034, arXiv:0904.2715 [hep-th].
- [7] E. Witten, “Geometric Langlands From Six Dimensions,” arXiv:0905.2720 [hep-th].
- [8] C. Montonen and D. I. Olive, “Magnetic Monopoles as Gauge Particles?,” *Phys. Lett.* **B72** (1977) 117–120.
- [9] A. Sen, “Dyon - monopole bound states, selfdual harmonic forms on the multi - monopole moduli space, and $SL(2, Z)$ invariance in string theory,” *Phys. Lett.* **B329** (1994) 217–221, arXiv:hep-th/9402032 [hep-th].
- [10] E. P. Verlinde, “Global aspects of electric - magnetic duality,” *Nucl. Phys.* **B455** (1995) 211–228, arXiv:hep-th/9506011 [hep-th].
- [11] J. J. Heckman, D. R. Morrison, and C. Vafa, “On the Classification of 6D SCFTs and Generalized ADE Orbifolds,” *JHEP* **05** (2014) 028, arXiv:1312.5746 [hep-th]. [Erratum: JHEP06,017(2015)].
- [12] J. J. Heckman, D. R. Morrison, T. Rudelius, and C. Vafa, “Atomic Classification of 6D SCFTs,” *Fortsch. Phys.* **63** (2015) 468–530, arXiv:1502.05405 [hep-th].
- [13] M. Del Zotto, J. J. Heckman, A. Tomasiello, and C. Vafa, “6d Conformal Matter,” *JHEP* **02** (2015) 054, arXiv:1407.6359 [hep-th].

- [14] K. Ohmori, H. Shimizu, Y. Tachikawa, and K. Yonekura, “6d $\mathcal{N}=(1,0)$ theories on T^2 and class S theories: Part I,” *JHEP* **07** (2015) 014, arXiv:1503.06217 [hep-th].
- [15] K. Ohmori and H. Shimizu, “ S^1/T^2 compactifications of 6d $\mathcal{N}=(1,0)$ theories and brane webs,” *JHEP* **03** (2016) 024, arXiv:1509.03195 [hep-th].
- [16] K. Ohmori, H. Shimizu, Y. Tachikawa, and K. Yonekura, “6d $\mathcal{N}=(1,0)$ theories on S^1/T^2 and class S theories: part II,” *JHEP* **12** (2015) 131, arXiv:1508.00915 [hep-th].
- [17] O. Aharony, A. Hanany, and B. Kol, “Webs of (p,q) five-branes, five-dimensional field theories and grid diagrams,” *JHEP* **01** (1998) 002, arXiv:hep-th/9710116 [hep-th].
- [18] F. Benini, S. Benvenuti, and Y. Tachikawa, “Webs of five-branes and $N=2$ superconformal field theories,” *JHEP* **09** (2009) 052, arXiv:0906.0359 [hep-th].
- [19] C. Cordova, T. T. Dumitrescu, and K. Intriligator, “Deformations of Superconformal Theories,” arXiv:1602.01217 [hep-th].
- [20] P. Pasti, D. P. Sorokin, and M. Tonin, “Note on manifest Lorentz and general coordinate invariance in duality symmetric models,” *Phys. Lett.* **B352** (1995) 59–63, arXiv:hep-th/9503182 [hep-th].
- [21] D. Belov and G. W. Moore, “Holographic Action for the Self-Dual Field,” arXiv:hep-th/0605038 [hep-th].
- [22] S. Deser, A. Gomberoff, M. Henneaux, and C. Teitelboim, “Duality, selfduality, sources and charge quantization in Abelian N form theories,” *Phys. Lett.* **B400** (1997) 80–86, arXiv:hep-th/9702184 [hep-th].
- [23] E. Bergshoeff, E. Sezgin, and E. Sokatchev, “Couplings of selfdual tensor multiplet in six-dimensions,” *Class. Quant. Grav.* **13** (1996) 2875–2886, arXiv:hep-th/9605087 [hep-th].
- [24] A. Sagnotti, “A Note on the Green-Schwarz mechanism in open string theories,” *Phys. Lett.* **B294** (1992) 196–203, arXiv:hep-th/9210127 [hep-th].
- [25] M. B. Green and J. H. Schwarz, “Anomaly Cancellation in Supersymmetric $D=10$ Gauge Theory and Superstring Theory,” *Phys. Lett.* **B149** (1984) 117–122.
- [26] S. Monnier, “The global anomaly of the self-dual field in general backgrounds,” arXiv:1309.6642 [hep-th].
- [27] L. Bhardwaj, “Classification of 6d $\mathcal{N}=(1,0)$ gauge theories,” *JHEP* **11** (2015) 002, arXiv:1502.06594 [hep-th].
- [28] M. Bershadsky and C. Vafa, “Global anomalies and geometric engineering of critical theories in six-dimensions,” arXiv:hep-th/9703167 [hep-th].

- [29] V. Sadov, “Generalized Green-Schwarz mechanism in F theory,” *Phys. Lett.* **B388** (1996) 45–50, arXiv:hep-th/9606008 [hep-th].
- [30] L. Bhardwaj, D. R. Morrison, Y. Tachikawa, and T. Alessandro, “Frozen Phases of F-theory.” work in progress.
- [31] D. R. Morrison and T. Rudelius, “F-theory and Unpaired Tensors in 6D SCFTs and LSTs,” arXiv:1605.08045 [hep-th].
- [32] M. Henningson, “Self-dual strings in six dimensions: Anomalies, the ADE-classification, and the world-sheet WZW-model,” *Commun. Math. Phys.* **257** (2005) 291–302, arXiv:hep-th/0405056 [hep-th].
- [33] K. Hori, “Consistency condition for five-brane in M theory on $R^{*5} / Z(2)$ orbifold,” *Nucl. Phys.* **B539** (1999) 35–78, arXiv:hep-th/9805141 [hep-th].
- [34] J. A. Harvey, R. Minasian, and G. W. Moore, “NonAbelian tensor multiplet anomalies,” *JHEP* **09** (1998) 004, arXiv:hep-th/9808060 [hep-th].
- [35] D. Freed, J. A. Harvey, R. Minasian, and G. W. Moore, “Gravitational anomaly cancellation for M theory five-branes,” *Adv. Theor. Math. Phys.* **2** (1998) 601–618, arXiv:hep-th/9803205 [hep-th].
- [36] K. A. Intriligator, “Anomaly matching and a Hopf-Wess-Zumino term in 6d, $N=(2,0)$ field theories,” *Nucl. Phys.* **B581** (2000) 257–273, arXiv:hep-th/0001205 [hep-th].
- [37] P. Yi, “Anomaly of $(2,0)$ theories,” *Phys. Rev.* **D64** (2001) 106006, arXiv:hep-th/0106165 [hep-th].
- [38] F. Bonetti, T. W. Grimm, and S. Hohenegger, “One-loop Chern-Simons terms in five dimensions,” *JHEP* **07** (2013) 043, arXiv:1302.2918 [hep-th].
- [39] N. Seiberg and E. Witten, “Comments on string dynamics in six-dimensions,” *Nucl. Phys.* **B471** (1996) 121–134, arXiv:hep-th/9603003 [hep-th].
- [40] P. Hořava and E. Witten, “Heterotic and type I string dynamics from eleven-dimensions,” *Nucl. Phys.* **B460** (1996) 506–524, arXiv:hep-th/9510209 [hep-th].
- [41] P. Hořava and E. Witten, “Eleven-dimensional supergravity on a manifold with boundary,” *Nucl. Phys.* **B475** (1996) 94–114, arXiv:hep-th/9603142 [hep-th].
- [42] D. R. Morrison and N. Seiberg, “Extremal transitions and five-dimensional supersymmetric field theories,” *Nucl. Phys.* **B483** (1997) 229–247, arXiv:hep-th/9609070 [hep-th].
- [43] K. Ohmori, H. Shimizu, and Y. Tachikawa, “Anomaly polynomial of E-string theories,” *JHEP* **08** (2014) 002, arXiv:1404.3887 [hep-th].

- [44] J. de Boer, R. Dijkgraaf, K. Hori, A. Keurentjes, J. Morgan, D. R. Morrison, and S. Sethi, “Triples, fluxes, and strings,” *Adv. Theor. Math. Phys.* **4** (2002) 995–1186, arXiv:hep-th/0103170 [hep-th].
- [45] M. Atiyah and E. Witten, “M theory dynamics on a manifold of G(2) holonomy,” *Adv. Theor. Math. Phys.* **6** (2003) 1–106, arXiv:hep-th/0107177 [hep-th].
- [46] Y. Tachikawa, “Frozen,” arXiv:1508.06679 [hep-th].
- [47] Y. Tachikawa. Private communication, 2016.
- [48] A. Borel, R. Friedman, and J. W. Morgan, “Almost commuting elements in compact Lie groups,” arXiv:math/9907007 [math].
- [49] M. R. Douglas and G. W. Moore, “D-branes, quivers, and ALE instantons,” arXiv:hep-th/9603167 [hep-th].
- [50] D. Gaiotto and E. Witten, “Supersymmetric Boundary Conditions in N=4 Super Yang-Mills Theory,” *J. Statist. Phys.* **135** (2009) 789–855, arXiv:0804.2902 [hep-th].
- [51] I. Brunner and A. Karch, “Branes and six-dimensional fixed points,” *Phys. Lett.* **B409** (1997) 109–116, arXiv:hep-th/9705022 [hep-th].
- [52] A. Hanany and A. Zaffaroni, “Branes and six-dimensional supersymmetric theories,” *Nucl. Phys.* **B529** (1998) 180–206, arXiv:hep-th/9712145 [hep-th].
- [53] D. Gaiotto and A. Tomasiello, “Holography for (1,0) theories in six dimensions,” *JHEP* **12** (2014) 003, arXiv:1404.0711 [hep-th].
- [54] J. J. Heckman, T. Rudelius, and A. Tomasiello, “6D RG Flows and Nilpotent Hierarchies,” arXiv:1601.04078 [hep-th].
- [55] P. S. Aspinwall and D. R. Morrison, “Point - like instantons on K3 orbifolds,” *Nucl. Phys.* **B503** (1997) 533–564, arXiv:hep-th/9705104 [hep-th].
- [56] E. Gorbatov, V. S. Kaplunovsky, J. Sonnenschein, S. Theisen, and S. Yankielowicz, “On heterotic orbifolds, M theory and type I-prime brane engineering,” *JHEP* **05** (2002) 015, arXiv:hep-th/0108135 [hep-th].
- [57] M. R. Douglas, S. H. Katz, and C. Vafa, “Small instantons, Del Pezzo surfaces and type I-prime theory,” *Nucl. Phys.* **B497** (1997) 155–172, arXiv:hep-th/9609071 [hep-th].
- [58] Y. Tachikawa, “On the 6d origin of discrete additional data of 4d gauge theories,” *JHEP* **05** (2014) 020, arXiv:1309.0697 [hep-th].

- [59] O. J. Ganor, D. R. Morrison, and N. Seiberg, “Branes, Calabi-Yau spaces, and toroidal compactification of the N=1 six-dimensional E(8) theory,” *Nucl. Phys.* **B487** (1997) 93–127, arXiv:hep-th/9610251 [hep-th].
- [60] D. Gaiotto and S. S. Razamat, “ $\mathcal{N} = 1$ theories of class \mathcal{S}_k ,” *JHEP* **07** (2015) 073, arXiv:1503.05159 [hep-th].
- [61] D. R. Morrison and C. Vafa, “F-Theory and N=1 SCFTs in Four Dimensions,” arXiv:1604.03560 [hep-th].
- [62] S. Franco, H. Hayashi, and A. Uranga, “Charting Class \mathcal{S}_k Territory,” *Phys. Rev.* **D92** no. 4, (2015) 045004, arXiv:1504.05988 [hep-th].
- [63] D. R. Morrison and C. Vafa, “Compactifications of F theory on Calabi-Yau threefolds. 1,” *Nucl. Phys.* **B473** (1996) 74–92, arXiv:hep-th/9602114 [hep-th].
- [64] D. R. Morrison and C. Vafa, “Compactifications of F theory on Calabi-Yau threefolds. 2.,” *Nucl. Phys.* **B476** (1996) 437–469, arXiv:hep-th/9603161 [hep-th].
- [65] A. D. Shapere and Y. Tachikawa, “Central charges of N=2 superconformal field theories in four dimensions,” *JHEP* **09** (2008) 109, arXiv:0804.1957 [hep-th].
- [66] E. Witten, “On S duality in Abelian gauge theory,” *Selecta Math.* **1** (1995) 383, arXiv:hep-th/9505186 [hep-th].
- [67] D. Anselmi, D. Z. Freedman, M. T. Grisaru, and A. A. Johansen, “Nonperturbative formulas for central functions of supersymmetric gauge theories,” *Nucl. Phys.* **B526** (1998) 543–571, arXiv:hep-th/9708042 [hep-th].
- [68] D. Anselmi, J. Erlich, D. Z. Freedman, and A. A. Johansen, “Positivity constraints on anomalies in supersymmetric gauge theories,” *Phys. Rev.* **D57** (1998) 7570–7588, arXiv:hep-th/9711035 [hep-th].
- [69] S. M. Kuzenko and S. Theisen, “Correlation functions of conserved currents in N=2 superconformal theory,” *Class. Quant. Grav.* **17** (2000) 665–696, arXiv:hep-th/9907107 [hep-th].
- [70] N. Seiberg and E. Witten, “Electric - magnetic duality, monopole condensation, and confinement in N=2 supersymmetric Yang-Mills theory,” *Nucl. Phys.* **B426** (1994) 19–52, arXiv:hep-th/9407087 [hep-th]. [Erratum: Nucl. Phys.B430,485(1994)].
- [71] O. Aharony and Y. Tachikawa, “A Holographic computation of the central charges of d=4, N=2 SCFTs,” *JHEP* **01** (2008) 037, arXiv:0711.4532 [hep-th].
- [72] M. Del Zotto, C. Vafa, and D. Xie, “Geometric engineering, mirror symmetry and $6d_{(1,0)} \rightarrow 4d_{(\mathcal{N}=2)}$,” *JHEP* **11** (2015) 123, arXiv:1504.08348 [hep-th].

- [73] O. Chacaltana, J. Distler, and Y. Tachikawa, “Nilpotent orbits and codimension-two defects of 6d $N=(2,0)$ theories,” *Int. J. Mod. Phys. A* **28** (2013) 1340006, arXiv:1203.2930 [hep-th].
- [74] K. Maruyoshi, Y. Tachikawa, W. Yan, and K. Yonekura, “ $N=1$ dynamics with T_N theory,” *JHEP* **10** (2013) 010, arXiv:1305.5250 [hep-th].
- [75] Y. Tachikawa, “A review of the T_N theory and its cousins,” *PTEP* **2015** no. 11, (2015) 11B102, arXiv:1504.01481 [hep-th].
- [76] E. Brieskorn, “Singular elements of semi-simple algebraic groups,” in *Actes du Congrès International des Mathématiciens (Nice, 1970), Tome 2*, pp. 279–284. Gauthier-Villars, Paris, 1971.
- [77] P. Slodowy, *Simple singularities and simple algebraic groups*, vol. 815 of *Lecture Notes in Mathematics*. Springer, Berlin, 1980.
- [78] G. Zafrir, “Brane webs, 5d gauge theories and 6d $\mathcal{N}=(1,0)$ SCFT’s,” *JHEP* **12** (2015) 157, arXiv:1509.02016 [hep-th].
- [79] D. Gaiotto and S. S. Razamat, “Exceptional Indices,” *JHEP* **05** (2012) 145, arXiv:1203.5517 [hep-th].
- [80] O. Chacaltana and J. Distler, “Tinkertoys for Gaiotto Duality,” *JHEP* **11** (2010) 099, arXiv:1008.5203 [hep-th].
- [81] O. DeWolfe, T. Hauer, A. Iqbal, and B. Zwiebach, “Uncovering the symmetries on $[p, q]$ seven-branes: Beyond the Kodaira classification,” *Adv. Theor. Math. Phys.* **3** (1999) 1785–1833, arXiv:hep-th/9812028 [hep-th].
- [82] O. DeWolfe, “Affine Lie algebras, string junctions and seven-branes,” *Nucl. Phys.* **B550** (1999) 622–637, arXiv:hep-th/9809026 [hep-th].
- [83] O. DeWolfe, A. Hanany, A. Iqbal, and E. Katz, “Five-branes, seven-branes and five-dimensional $E(n)$ field theories,” *JHEP* **03** (1999) 006, arXiv:hep-th/9902179 [hep-th].
- [84] H. Hayashi, S.-S. Kim, K. Lee, M. Taki, and F. Yagi, “A new 5d description of 6d D-type minimal conformal matter,” *JHEP* **08** (2015) 097, arXiv:1505.04439 [hep-th].
- [85] A. Sen, “F theory and orientifolds,” *Nucl. Phys.* **B475** (1996) 562–578, arXiv:hep-th/9605150 [hep-th].
- [86] S.-S. Kim, M. Taki, and F. Yagi, “Tao Probing the End of the World,” *PTEP* **2015** no. 8, (2015) 083B02, arXiv:1504.03672 [hep-th].
- [87] M. R. Douglas, “On D=5 super Yang-Mills theory and (2,0) theory,” *JHEP* **02** (2011) 011, arXiv:1012.2880 [hep-th].

- [88] N. Lambert, C. Papageorgakis, and M. Schmidt-Sommerfeld, “M5-Branes, D4-Branes and Quantum 5D super-Yang-Mills,” *JHEP* **01** (2011) 083, arXiv:1012.2882 [hep-th].
- [89] Y. Tachikawa, “Instanton operators and symmetry enhancement in 5d supersymmetric gauge theories,” *PTEP* **2015** no. 4, (2015) 043B06, arXiv:1501.01031 [hep-th].
- [90] K. Yonekura, “Instanton operators and symmetry enhancement in 5d supersymmetric quiver gauge theories,” *JHEP* **07** (2015) 167, arXiv:1505.04743 [hep-th].
- [91] O. Aharony and A. Hanany, “Branes, superpotentials and superconformal fixed points,” *Nucl. Phys.* **B504** (1997) 239–271, arXiv:hep-th/9704170 [hep-th].
- [92] O. Bergman and G. Zafrir, “Lifting 4d dualities to 5d,” *JHEP* **04** (2015) 141, arXiv:1410.2806 [hep-th].
- [93] H. Hayashi, Y. Tachikawa, and K. Yonekura, “Mass-deformed T_N as a linear quiver,” *JHEP* **02** (2015) 089, arXiv:1410.6868 [hep-th].
- [94] D. Gaiotto and J. Maldacena, “The Gravity duals of $N=2$ superconformal field theories,” *JHEP* **10** (2012) 189, arXiv:0904.4466 [hep-th].
- [95] D. Gaiotto, G. W. Moore, and Y. Tachikawa, “On 6d $\mathcal{N}=(2,0)$ theory compactified on a Riemann surface with finite area,” *PTEP* **2013** (2013) 013B03, arXiv:1110.2657 [hep-th].
- [96] Y. Tachikawa, “ $N=2$ supersymmetric dynamics for pedestrians,” in *Lecture Notes in Physics, vol. 890, 2014*, vol. 890, p. 2014. 2013. arXiv:1312.2684 [hep-th].
<https://inspirehep.net/record/1268680/files/arXiv:1312.2684.pdf>.
- [97] O. Chacaltana and J. Distler, “Tinkertoys for the D_N series,” *JHEP* **02** (2013) 110, arXiv:1106.5410 [hep-th].
- [98] O. Chacaltana, J. Distler, and A. Trimm, “Tinkertoys for the E_6 theory,” *JHEP* **09** (2015) 007, arXiv:1403.4604 [hep-th].
- [99] O. Chacaltana, J. Distler, and Y. Tachikawa, “Gaiotto duality for the twisted A_{2N-1} series,” *JHEP* **05** (2015) 075, arXiv:1212.3952 [hep-th].
- [100] A. Hanany and K. Maruyoshi, “Chiral theories of class \mathcal{S} ,” *JHEP* **12** (2015) 080, arXiv:1505.05053 [hep-th].
- [101] J. Erler, “Anomaly cancellation in six-dimensions,” *J. Math. Phys.* **35** (1994) 1819–1833, arXiv:hep-th/9304104 [hep-th].