

Fermionic rational conformal field theories and modular linear differential equations

Jin-Beom Bae¹, Zhihao Duan², Kimyeong Lee^{2,*}, Sungjay Lee², and Matthieu Sarkis^{2,†}

¹*Mathematical Institute, University of Oxford, Andrew Wiles Building, Radcliffe Observatory Quarter, Woodstock Road, Oxford, OX2 6GG, UK*

²*Korea Institute for Advanced Study, 85 Hoegiro, Dongdaemun-Gu, Seoul 02455, Korea*

*E-mail: klee@kias.re.kr

The authors contributed equally to this work.

Received December 28, 2020; Revised February 15, 2021; Accepted February 17, 2020; Published March 10, 2021

.....
 We define modular linear differential equations (MLDE) for the level-two congruence subgroups Γ_θ , $\Gamma^0(2)$ and $\Gamma_0(2)$ of $SL_2(\mathbb{Z})$. Each subgroup corresponds to one of the spin structures on the torus. The pole structures of the fermionic MLDEs are investigated by exploiting the valence formula for the level-two congruence subgroups. We focus on the first- and second-order holomorphic MLDEs without poles and use them to find a large class of “fermionic rational conformal field theories” (fermionic RCFTs), which have non-negative integer coefficients in the q -series expansion of their characters. We study the detailed properties of these fermionic RCFTs, some of which are supersymmetric. This work also provides a starting point for the classification of the fermionic modular tensor category.

Subject Index B16, B24, B34

1. Introduction and concluding remarks

The classification of all unitary conformal field theories in two dimensions certainly plays a key role in our understanding of the critical phenomena. Utilizing the conformal and modular bootstraps, the unitary conformal field theories with $c < 1$ in particular can be solved and classified completely [1]. They are called minimal models and obey the so-called ADE classification. One of the important features of minimal models is that they have finitely many conformal primaries. This admits a generalization that leads to a very rich class of two-dimensional conformal field theories, namely rational conformal field theories. A rational conformal field theory (RCFT) refers to a conformal field theory whose torus partition function can be expressed as a finite sum of products of holomorphic and anti-holomorphic functions. Such holomorphic functions can be understood as characters with respect to an extended chiral algebra that includes Virasoro algebra. It is well-known that, in a given RCFT, the central charge as well as conformal weights are rational numbers [2,3]. One prominent example of an RCFT is the Wess–Zumino–Witten (WZW) model where the extended chiral algebra is the current algebra.

A few approaches based on chiral algebras and lattices have been proposed to solve a more tractable problem of the classification of RCFTs [4–7]. Since there are RCFTs that fit into neither of those approaches, the classification however remains incomplete. On the other hand, the authors of Ref. [8] have proposed a rather different approach based on the modular invariant linear differential equations (MLDEs).

Let us first briefly explain how an MLDE can provide a systematic procedure to classify the RCFTs. Suppose that a given RCFT has N independent characters. From the modular invariance of the torus partition function, one can see that the holomorphic characters transform as a vector-valued modular form under $SL_2(\mathbb{Z})$. This implies that the N characters can be regarded as independent solutions to an N th order differential equation invariant under $SL_2(\mathbb{Z})$. This method is particularly useful to obtain a complete list for RCFTs with small numbers of characters, which was studied extensively in Ref. [8]. The classification of the super-characters in $\mathcal{N} = 1$ superconformal field theory (SCFT) is considered in Ref. [9]. Readers can also find a recent status on this programme in Ref. [10] and the references therein.

Rational conformal field theories are also closely related to the modular tensor categories (MTC) that have extensive applications to the study of anyonic systems and topological quantum computation [11–13]. When two different RCFTs are related to two MTCs conjugate to each other, it turns out that they satisfy a certain bilinear relation studied recently in Refs. [14–17]. Given that the MTCs of low rank are only classified in Refs. [18,19], we expect that the classification of RCFTs based on the MLDE sheds new light on the problem of the classification of MTCs. Recently the classification of fermionic MTCs was considered as a view toward the three-dimensional topological field theories [20,21].

In the present work, we extend the MLDE method to classify the fermionic rational conformal field theories (CFTs), some of which appear to be supersymmetric. A fermionic CFT refers to a conformal field theory which contains operators of half-integer spin. To define a fermionic CFT on a manifold, one has to choose a spin structure. On a torus, there are four different spin structures, (NS, NS), (R, NS), (NS, R) and (R, R). For later convenience, we use the shorthand notation NS, $\widetilde{\text{NS}}$, R and $\widetilde{\text{R}}$ for those spin structures. A fermionic CFT in our study is further restricted to have a certain extended chiral algebra that includes conserved currents of half-integer weight. In other words, there are half-integer spin descendants of the vacuum in the NS sector.

It is well-known that the Jordan–Wigner transformation maps the critical Ising model to a theory of free Majorana fermions. Since that discovery, the Jordan–Wigner transformation was revisited to fermionize a given bosonic CFT with a non-anomalous \mathbb{Z}_2 to a fermionic CFT [22–24]. Along the way, the “Beauty and the Beast” $\mathcal{N} = 1$ superconformal theory [25] can be reinterpreted as a fermionization of the Monster CFT [26], and the fermionic minimal models are constructed in Refs. [27–29]. The goal of this paper is to classify such fermionic RCFTs with small numbers of conformal characters systematically via the MLDE method. The classification of fermionic RCFTs will provide the classification of the fermionic modular tensor category that characterizes the fermionic topological phases of matter, modulo the fact that two different fermionic RCFTs sharing the same fusion-rule algebra are related to a single fermionic MTC.

In order to discuss the extension of the MLDE method, let us note that the characters of a given fermionic RCFT in NS, $\widetilde{\text{NS}}$, and R sectors become vector-valued modular functions for the level-two congruence subgroups Γ_θ , $\Gamma^0(2)$ and $\Gamma_0(2)$ of the modular group. This is because each of these congruence subgroups is associated to a specific spin structure on the torus, i.e., NS, $\widetilde{\text{NS}}$, and R sectors. Hence each of the “fermionic” MLDEs associated to them transform into each other under $SL_2(\mathbb{Z})$ transformations.

The first step consists of understanding the relation between the pole structure of the coefficients of the MLDE and the set of zeros of the characters which are solutions to the MLDE. This was neatly understood in the case of $SL_2(\mathbb{Z})$ (see for instance Ref. [8]) in terms of the zeros of the Wronskian associated to the MLDE. Having automorphic properties, the Wronskian happens to be subject to the

so-called valence formula, a classical result in the theory of modular forms constraining the possible set of zeros (together with their multiplicity) in terms of the weight of the automorphic form. This allows the reduction of the choice of the pole structure characterizing the order N MLDE down to the choice of a single integer ℓ . In this paper, we introduce the equivalent of the valence formula for various relevant level-two congruence subgroups of $\mathrm{SL}_2(\mathbb{Z})$. Equipped with this tool, we generalize the MLDE to the case of level-two congruence subgroups Γ_θ , $\Gamma^0(2)$ and $\Gamma_0(2)$ of the modular group. The level-two valence formula boils down to the following relation between the central charge c , the conformal weights in the NS and R sectors h^{NS} and h^{R} , N and ℓ :

$$-\frac{Nc}{8} + 2 \sum_j h_j^{\mathrm{NS}} + \sum_j h_j^{\mathrm{R}} + \frac{\ell}{2} = \frac{N(N-1)}{4}. \quad (1)$$

After discussing the possible poles structures for a fermionic MLDE in terms of the level-two congruence subgroups valence formula, we focus on the second-order fermionic MLDE in the simplest case; that of a trivial pole structure. In this context, we classify the possible values of the central charge and conformal weights corresponding to some fermionic RCFT for which there exist character-like solutions to the fermionic MLDE. More precisely, we consider the solutions with the property that all the coefficients are non-negative integers in q -series. We classify the solutions using six classes, which can be found later in Table 4. In particular, we also derive a closed-form expression of the S -matrix of these fermionic RCFTs and investigate their fusion coefficients. We discard the solutions of the second-order fermionic MLDE when they do not yield a consistent fusion rule algebra. For the solutions with consistent fusion rule algebra, we find the identifications in terms of the $\mathcal{N} = 1$ supersymmetric minimal models or the WZW models.

One can construct the partition function of individual spin structures using the solutions of the second-order fermionic MLDE. The sum of four partition functions defines an $\mathrm{SL}_2(\mathbb{Z})$ invariant partition function of a certain bosonic CFT, and this procedure is often referred to as the Gliozzi-Scherk-Olive (GSO) projection [30], or, equivalently, bosonization. In some of the cases we study below, we find that the bosonization works with the assumption that the torus partition function for the spin structure \tilde{R} becomes constant; $Z_{\tilde{R}} = \text{const}$. In particular, when the following three conditions are satisfied,

- (1) a vacuum descendant of weight $3/2$ is present,
- (2) the supersymmetric unitarity bound $h^{\mathrm{R}} \geq c/24$ is obeyed,
- (3) $Z_{\tilde{R}} = \text{constant}$,

then we suggest interpreting the corresponding solutions as the characters of unitary supersymmetric RCFT. For instance, we will show that the fermionization of $su(2)_6$ and a $(\epsilon_6)_3$ WZW model could potentially be understood as a supersymmetric RCFT, as they satisfy the above three conditions. More examples will be discussed in the main context.

We also notice that some solutions can be combined into known partition functions, e.g., the Conway extremal CFT [31] or the $\mathcal{N} = 1$ extension of the $(\epsilon_8)_1$ WZW model. This will be referred to as a bilinear relation in what follows. When such a bilinear relation is satisfied for the characters of two different RCFTs, these two theories ought to share the same fusion rule algebra. Therefore, we expect that our classification will provide new insight into fermionic MTCs. On the one hand, some bilinear relations are known to appear as evidence of deconstruction of the Monster group [16,17]. In a similar way, we test the splitting of the supersymmetric vertex operator algebra (VOA) for the Conway

group Co_0 with $c = 12$. Specifically, the solution with $c = 11$ exhibits moonshine phenomena for the Suzuki group, as shown in Ref. [32]. Further examples of fermionic deconstructions will be discussed in an upcoming paper [33].

In a separate upcoming paper [34], we generalize the work of the present paper to the case of a third-order fermionic MLDE. There, we focus on a subfamily of solutions for which the BPS bound is saturated in the Ramond sector. We provide a closed-form expression of the characters and the S -matrix for these solutions.

This article is organized as follows. In Sect. 2, we review some mathematical facts concerning the modular group $SL_2(\mathbb{Z})$ and the well-known classification of second-order MLDEs by Ref. [8]. In Sect. 3, we introduce some standard results of three level-two congruence subgroups and propose MLDEs with holomorphic coefficients, to which we also refer as (holomorphic) fermionic MLDEs. Then we move on to finding solutions that can possibly be identified as characters of fermionic RCFTs. In Sect. 4, we classify all possible solutions of fermionic first-order MLDEs, which turn out to consist of products of Majorana–Weyl fermions. In Sect. 5, we study fermionic second-order MLDEs with trivial pole structures and find six families of solutions, listed later in Table 4. We are able to express all the consistent solutions in terms of the characters of some known RCFT.

We would like to dedicate this article to the memory of Professor Tohru Eguchi. We notice that other articles dedicated to Prof. Eguchi in PTEP also has the dedication at the last paragraph of the introduction. It is conventional in our community, who passed away last year. K.L. recalls a personal meeting with him about 20 years ago during his visit to Tokyo University and many more wonderful interactions later on. Many of our works got influenced by Prof. Eguchi's works. In relation to this article, we note that in Ref. [35] Eguchi and Ooguri derived the third-order MLDE for conformal characters of the Ising model as well as the exact form of the characters. This is the first place that the MLDE made its appearance in the study of conformal field theories. Anderson and Moore wrote a general MLDE and used it to show the rationality of c and h for rational conformal field theories [2]. Afterwards, Mathur, Mukhi and Sen (MMS) [8] expanded and established the MLDE and utilized it as a tool for the classification of RCFTs. They found the famous MMS series of theories discussed in Sect. 2.2.

2. Modular linear differential equation for $SL_2(\mathbb{Z})$

2.1. $SL_2(\mathbb{Z})$ group and its valence formula

It is natural to consider RCFTs on a torus. The partition function of the theory is required to be modular-invariant. Thus, the modular group $SL_2(\mathbb{Z})$ plays an essential role in our understanding of the conformal field theory. Here we review its important features relevant to our analysis.

The modular group $SL_2(\mathbb{Z})$ is a group of invertible 2×2 matrices with integer coefficients and unit determinant:

$$SL_2(\mathbb{Z}) = \left\{ \gamma = \begin{pmatrix} a & b \\ c & d \end{pmatrix} \mid a, b, c, d \in \mathbb{Z}, ad - bc = 1 \right\}. \quad (2)$$

The modular group is generated by $S = \begin{pmatrix} 0 & -1 \\ 1 & 0 \end{pmatrix}$ and $T = \begin{pmatrix} 1 & 1 \\ 0 & 1 \end{pmatrix}$. The modular parameter $\tau \in \mathbb{H} = \{\tau \in \mathbb{C} \mid \text{Im}(\tau) > 0\}$ transforms by fractional linear transformations as $\gamma\tau = (a\tau + b)/(c\tau + d)$. The fundamental domain $\mathcal{D} = SL_2(\mathbb{Z}) \backslash \mathbb{H}$ for the modular group $SL_2(\mathbb{Z})$ is given as

$$\mathcal{D}(SL_2(\mathbb{Z})) = \left\{ \tau \in \mathbb{H} \mid |\text{Re}(\tau)| \leq \frac{1}{2}, |\tau| \geq 1 \right\}, \quad (3)$$

with additional identification of the boundaries by $T : \tau \rightarrow \tau + 1$ and $S : \tau \rightarrow -1/\tau$. The fundamental domain is drawn in Fig. 1. The term $\tau = i$ is an orbifold point of order two and $\tau = \omega \equiv e^{2\pi i/3}$ is an orbifold point of order three. The topology of the fundamental domain is a sphere with a single puncture, the *cusp* at $i\infty$.

Given an element $\gamma \in \text{SL}_2(\mathbb{Z})$, one defines the following action on functions $f(\tau)$ from \mathbb{H} to \mathbb{C} :

$$(f|_k\gamma)(\tau) \equiv \rho(\gamma)^{-1}(c\tau + d)^{-k}f(\gamma\tau), \tag{4}$$

where $\rho(\gamma)$ is a possibly non-trivial γ -dependent phase, and k is an integer called the weight of f . If the function f is periodic under $T : \tau \rightarrow \tau + 1$ so that $\rho(T) = 1$, we can have a Fourier expansion:

$$f(\tau) = \sum_{k=-\infty}^{\infty} a_k q^k, \quad q \equiv e^{2\pi i\tau}. \tag{5}$$

The function f is *meromorphic* at $i\infty$ if only a finite number of negative powers of q appears in the above expansion, *holomorphic* at $i\infty$ if there is no negative power of q , and *vanishes* at $i\infty$ if only positive powers of q appear.

Let us first focus on the $\text{SL}_2(\mathbb{Z})$ weight k forms which have the following property:

$$(f|_k\gamma)(\tau) = f(\tau) \text{ with } \rho(\gamma) = 1, \text{ for all } \gamma \in \text{SL}_2(\mathbb{Z}) \text{ and for all } \tau \in \mathbb{H}. \tag{6}$$

These functions f can be extended to maps $f : \overline{\mathbb{H}} \rightarrow \mathbb{C}$ where $\overline{\mathbb{H}} = \mathbb{H} \cup \{i\infty\}$. Depending on the pole structures of these weight k forms, we call them *automorphic* forms if they have poles in \mathbb{H} , *weakly holomorphic* forms if they are holomorphic on \mathbb{H} and have poles at $i\infty$, *modular* forms if they are holomorphic on $\overline{\mathbb{H}}$, and *cusp* forms if they are holomorphic in \mathbb{H} and vanish at $i\infty$. The Klein $j(\tau)$ -invariant is a weakly holomorphic function, that is, a form of weight zero with simple pole $\tau = i\infty$. Eisenstein series E_4, E_6 are the only modular forms of weight 4 and 6, respectively. The modular discriminant $\Delta = E_4^3 - E_6^2 = 1728\eta^{24}$ is the only cusp form of weight 12. The detailed definitions of these functions are given in Appendix A.

In this work we are interested in the function space M_k of modular forms of weight k mainly. It is generated by E_4, E_6 Eisenstein series as follows:

$$\mathcal{M}_k(\text{SL}_2(\mathbb{Z})) = \bigoplus_{\substack{4a+6b=k \\ a,b \geq 0}} \mathbb{C}E_4^a E_6^b.$$

The dimension of M_k for $k \geq 2$ are well-known to satisfy

$$\sum_{k \in \mathbb{Z}} \dim(M_k)t^k = \frac{1}{(1-t^4)(1-t^6)}. \tag{7}$$

The space \mathcal{S}_k of cusp forms of weight k is related to the space of the modular forms as follows:

$$\mathcal{S}_k(\text{SL}_2(\mathbb{Z})) = \Delta(\tau)\mathcal{M}_{k-12}(\text{SL}_2(\mathbb{Z})). \tag{8}$$

For the class of functions $f : \mathbb{H} \rightarrow \mathbb{C}$ which satisfy $f|_k\gamma = f$ for any $\gamma \in \text{SL}_2(\mathbb{Z})$ of given weight k (4), holomorphic in \mathbb{H} and possibly meromorphic at $i\infty$, there exists a so-called valence formula relating the number of zeros in the fundamental domain $\text{SL}_2(\mathbb{Z}) \backslash \mathbb{H}$ to the weight k . Although it is a standard textbook material [36,37], let us review the derivation briefly, as we want to extend it to the case of level-two congruent subgroups later.

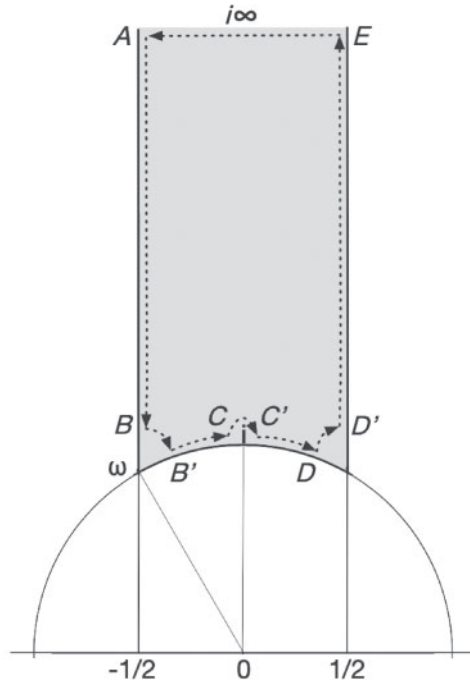

Fig. 1. Fundamental domain of $SL_2(\mathbb{Z})$ and the contour for the valence formula.

To get the valence formula, we use the Cauchy formula on the integration of $(\partial\tau f)/f$ along the contour given in Fig. 1, which is inside the fundamental domain $SL_2(\mathbb{Z}) \setminus \mathbb{H}$. The resulting integral can be evaluated in two ways;

$$\begin{aligned}
 -\frac{1}{2\pi i} \oint d\tau \frac{\frac{d}{d\tau} f(\tau)}{f(\tau)} &= - \sum_{\substack{p \in SL_2(\mathbb{Z}) \setminus \mathbb{H} \\ p \neq i, \omega, i\infty}} v_p(f) \\
 &= v_\infty(f) + \frac{1}{2}v_i(f) + \frac{1}{3}v_\omega(f) - \frac{k}{12},
 \end{aligned} \tag{9}$$

where $\omega = e^{2\pi i/3}$. For the first equality, the contour integration is split into integrals surrounding all the zeros in the interior of \mathbb{H} and becomes $-\sum_{\text{interior } p} v_p(f)$. The second equality comes from the contour integration along the boundary. One can read off the origin of each term in the right-hand side of the above equation from the dashed lines in Fig. 1. The contribution from each segment is

$$\begin{aligned}
 C_{EA} : v_\infty(f), \quad C_{CC'} : \frac{1}{2}v_i(f), \quad C_{BB'} + C_{DD'} : \frac{1}{3}v_\omega(f), \\
 C_{AB} + C_{D'E} : 0, \quad C_{B'C} + C_{C'D} : -\frac{k}{12}.
 \end{aligned} \tag{10}$$

The order $v_p(f) = n$ if $f(\tau)$ near $\tau = p$ has a Laurent expansion with leading term $f(\tau) \sim (\tau - p)^n$. For $f \sim q^n$ near $i\infty$, $\log(f) \sim 2\pi in \log \tau$ and so $v_\infty(f) = n$. At orbifold points i and ω , the contribution gets only $1/2$ and $1/3$ fractions, respectively, as one integrates over one-half or one-third of 2π integration. On the arc $C_{B'C}$ and $C_{C'D}$, a point τ and its S-dual points $-\tau^{-1}$ are matched. One changes the variable $\tau \rightarrow -1/\tau$ on $C_{B'C}$ and uses the fact $f(-1/\tau) = \rho(S) \tau^k f(\tau)$ to get that the contribution from the contour $C_{B'C}$ is minus of that from the contour $C_{C'D}$ together with $-k/12$. The factor $1/12$ is due to the fact that the angle between $\omega = e^{2\pi i/3}$ and i is $2\pi/12$.

Table 1. Weight k (weak) modular forms of $SL_2(\mathbb{Z})$.

$f(\tau)$	$\frac{k}{12}$	ν_∞	$\frac{1}{2}\nu_i$	$\frac{1}{3}\nu_\omega$
E_4	$\frac{1}{3}$	0	0	$\frac{1}{3}$
E_6	$\frac{1}{2}$	0	$\frac{1}{2}$	0
j	0	-1	0	1
Δ	1	1	0	0

In short, the valence formula for weight k form of $SL_2(\mathbb{Z})$ is

$$\nu_\infty(f) + \frac{1}{2}\nu_i(f) + \frac{1}{3}\nu_\omega(f) + \sum_{\substack{p \in SL_2(\mathbb{Z}) \setminus \mathbb{H} \\ p \neq i, \omega, i\infty}} \nu_p(f) = \frac{k}{12}. \tag{11}$$

Table 1 shows the validity of the valence formula for well-known modular forms which have no zeros or poles besides $i\infty, i$ and ω .

2.2. Modular linear differential equation

A two-dimensional rational conformal field theory of central charge c has a finite number of primary operators. Its modular invariant partition function on a torus can thus be expressed as

$$Z(\tau, \bar{\tau}) = \sum_{a,b=0}^{N-1} \mathcal{M}_{ab} \bar{\chi}_a(\bar{\tau}) \chi_b(\tau), \tag{12}$$

where χ_a ($\bar{\chi}_a$) denote left-moving (right-moving) characters with respect to an extended chiral algebra including the Virasoro algebra. The modular invariance of Eq. (12) implies that the characters $\chi_a(\tau)$ transform as a finite-dimensional representation of $SL_2(\mathbb{Z})$, i.e, they transform under S and T as follows:

$$\chi_a(-1/\tau) = \sum_{b=0}^{N-1} S_{ab} \chi_b(\tau), \quad \chi_a(\tau + 1) = \sum_{b=0}^{N-1} T_{ab} \chi_b(\tau), \tag{13}$$

where the modular matrices S_{ab} and T_{ab} are symmetric and satisfy the relations below

$$(S^\dagger \mathcal{M} S)_{ab} = \mathcal{M}_{ab}, \quad T_{ab} = q^{2\pi i h_a} \delta_{ab}, \tag{14}$$

where h_a is the conformal weight for χ_a . Note also that S_{ab} and T_{ab} should satisfy

$$S^2 = (ST)^3 = C, \tag{15}$$

where C is the charge conjugation matrix.

One can see from Eq. (13) that the characters of the RCFT constitute a vector-valued modular form of weight zero and thus satisfy an MLDE of order N where N is the number of linearly independent characters. Let us review the argument for the derivation of the MLDE in Refs. [8,38]. We start with an $(N + 1)$ -dimensional square matrix made of $\chi_0, \chi_1, \dots, \chi_{N-1}, f$ and their derivatives with the Ramanujan–Serre covariant derivative,

$$\mathcal{D} = \frac{1}{2\pi i} \frac{d}{d\tau} - \frac{r}{12} E_2(\tau), \tag{16}$$

acting on a weight r modular form, up to the N th power. This covariant derivative transforms a weight r modular form to weight $r + 2$ modular form. (See Appendix B for details.) If the function f is a linear combination of N characters, the determinant of this $(N + 1)$ -dimensional matrix vanishes, implying that

$$\sum_{k=0}^N (-1)^k W_k \mathcal{D}^k f = 0, \tag{17}$$

where each coefficient W_k is given by

$$W_k = \det \begin{pmatrix} \chi_0 & \cdots & \chi_{N-1} \\ \mathcal{D}\chi_0 & \cdots & \mathcal{D}\chi_{N-1} \\ \vdots & & \vdots \\ \mathcal{D}^{k-1}\chi_0 & \cdots & \mathcal{D}^{k-1}\chi_{N-1} \\ \mathcal{D}^{k+1}\chi_0 & \cdots & \mathcal{D}^{k+1}\chi_{N-1} \\ \vdots & & \vdots \\ \mathcal{D}^N\chi_0 & \cdots & \mathcal{D}^N\chi_{N-1} \end{pmatrix}. \tag{18}$$

One can recast Eq. (17) into

$$\left[\mathcal{D}^N + \sum_{k=0}^{N-1} \phi_k(\tau) \mathcal{D}^k \right] f(\tau) = 0, \tag{19}$$

where the coefficients $\phi_k(\tau) = (-1)^{N-k} W_k / W_N$ are automorphic forms of weight $2N - 2k$ for $SL_2(\mathbb{Z})$. These forms $\phi_k(\tau)$ could have poles at zeros of the Wronskian $W_N(\tau)$.

Let us first apply the valence formula (11) to the Wronskian $W_N(\tau)$, which transforms under S as a modular form of weight $N(N - 1)$ and is invariant under T up to a constant phase $\rho(T)$. At $\tau = i\infty$, the Wronskian has the asymptotic expansion

$$W_N(\tau) \sim q^{-\frac{Nc}{24} + \sum_a h_a} (1 + \mathcal{O}(q)), \tag{20}$$

because each character χ_a is asymptotic to

$$\chi_a \sim q^{-\frac{c}{24} + h_a} (1 + \mathcal{O}(q)) \quad \text{at } \tau = i\infty. \tag{21}$$

This implies that

$$v_{i\infty} = -\frac{Nc}{24} + \sum_{i=a}^{N-1} h_a, \tag{22}$$

and the valence formula (11) becomes

$$-\frac{Nc}{24} + \sum_a h_a + \frac{\ell}{6} = \frac{N(N - 1)}{12}, \tag{23}$$

where

$$\frac{\ell}{6} = \frac{1}{2} v_i + \frac{1}{3} v_\omega + \sum_{\text{interior}} v_\tau. \tag{24}$$

Table 2. c and h for the Mathur–Mukhi–Sen series.

	LY	α_1	α_2	\mathfrak{g}_2	\mathfrak{d}_4	\mathfrak{f}_4	\mathfrak{e}_6	\mathfrak{e}_7	$\mathfrak{e}_{7\frac{1}{2}}$	\mathfrak{e}_8
c	$-\frac{22}{5}$	1	2	$\frac{14}{5}$	4	$\frac{26}{5}$	6	7	$\frac{38}{5}$	8
h	$-\frac{1}{5}$	$\frac{1}{4}$	$\frac{1}{3}$	$\frac{5}{5}$	$\frac{1}{2}$	$\frac{3}{5}$	$\frac{2}{3}$	$\frac{3}{4}$	$\frac{4}{5}$	$[\frac{5}{6}]$
\mathcal{M}	1	1	2	1	3	1	2	1	1	[0]

The zeros of the Wronskian W_N become the poles of the coefficient functions ϕ_k . As the modular forms are covariant under the modular transformation, the coefficient ϕ_k of weight $2N - 2k$ can be expressed as rational functions of E_4 and E_6 , whose denominator is constrained by the parameter ℓ .

The second-order MLDE with $n = 2$ has been studied extensively in Refs. [8,38]. For the simple case without poles $\ell = 0$, the MLDE becomes

$$\left[\mathcal{D}^2 + \mu E_4 \right] f(\tau) = 0. \tag{25}$$

Note that the coefficient of the first derivative vanishes as there exists no modular form of weight 2, and E_4 is the unique modular form of weight 4 up to a constant factor. Two independent solutions to the above equation can be regarded as two characters that can be expanded in powers of q as follows:

$$\chi_0 \sim q^{-\frac{c}{24}}, \quad \chi_1 \sim q^{-\frac{c}{24} + h}. \tag{26}$$

Since the valence formula (23) says $h = (c + 2)/12$, the free parameter μ of Eq. (25) can be determined as $\mu = -[c(c + 4)]/576 = [(1 + 6h)(1 - 6h)]/144$. It has been shown in Ref. [8] that there exist only 10 values of allowed central charges,

$$c = \left\{ \frac{2}{5}, 1, 2, \frac{14}{5}, 4, \frac{26}{5}, 6, 7, \frac{38}{5}, 8 \right\}, \tag{27}$$

such that the solution of Eq. (26) has all q -expansion coefficients given by non-negative integers. Although the first case with $c = 2/5$ and $h = 1/5$ appears to be consistent, it has negative fusion coefficients. To resolve this, one interchanges the two characters and obtains a theory with $c = -22/5$ and $h = -1/5$. As discussed in Refs. [8,38], the above 10 solutions provide the characters for the Lee–Yang edge singularity and level-one WZW models for $\alpha_1, \alpha_2, \mathfrak{g}_2, \mathfrak{d}_4, \mathfrak{f}_4, \mathfrak{e}_6, \mathfrak{e}_7, \mathfrak{e}_{7\frac{1}{2}}, \mathfrak{e}_8$, respectively. This series of Lie groups is known as the Deligne–Cvitanovic series [39]. The explicit solutions to Eq. (19) as well as their S -matrix for each central charge c can be found in Ref. [40]. One can also show that the modular invariant partition function on the torus is diagonal, i.e.,

$$Z = |\chi_0|^2 + \mathcal{M} |\chi_1|^2, \tag{28}$$

where \mathcal{M} is a certain non-negative integer. We present the central charge c , and corresponding values of h and multiplicity \mathcal{M} , in Table 2.

As a remark, the WZW model for \mathfrak{e}_8 at level one appears in Table 2, but in fact it is a single-character RCFT. The vacuum character which is its unique character is given by

$$\chi_0^{\mathfrak{e}_8} = \frac{E_4(\tau)}{\eta(\tau)^8} = j(\tau)^{\frac{1}{3}}. \tag{29}$$

The characters of the above series also satisfy the bilinear relations

$$\chi_0^{\mathfrak{e}_8} = \chi_0^c \chi_0^{8-c} + \mathcal{M} \chi_1^c \chi_1^{8-c}. \tag{30}$$

This shows multiple ways to divide the ϵ_8 level-one WZW model into two pairs of complementary CFTs.

In the following sections, we generalize MLDEs to the fermionic theories including supersymmetric theories by considering the modular forms and the valence formula for the related congruence groups $\Gamma_\theta, \Gamma^0(2)$ and $\Gamma_0(2)$.

3. Congruence subgroups $\Gamma_\theta, \Gamma^0(2)$ and $\Gamma_0(2)$

3.1. $\Gamma_\theta, \Gamma^0(2), \Gamma_0(2), \Gamma(2)$ modular subgroups and forms

The level-two congruence subgroups $\Gamma_\theta, \Gamma^0(2)$ and $\Gamma_0(2)$ are related to the modular symmetry group of the fermionic conformal field theories in the NS-NS, R-NS and NS-R spin structure sectors of the partition functions, respectively. We will also refer to these three spin structures as NS, $\widetilde{\text{NS}}$ and R sectors, respectively. Their study provides a good starting point for building up fermionic MLDEs.

The principal congruence subgroup of $\text{SL}_2(\mathbb{Z})$ of level two, $\Gamma(2)$, is defined as follows:

$$\Gamma(2) = \left\{ \gamma \in \text{SL}_2(\mathbb{Z}) \mid \gamma \equiv \begin{pmatrix} 1 & 0 \\ 0 & 1 \end{pmatrix} \pmod{2} \right\}. \tag{31}$$

It is generated by $S^2 = -1, T^2, ST^2S$. Note that $S^2 = (ST)^2 = -1$. The weight two $\Gamma(2)$ modular forms, $\vartheta_a^4(\tau), a = 2, 3, 4$, are built out of the Jacobi theta functions and transform under S and T as

$$\begin{aligned} (\vartheta_2^4, \vartheta_3^4, \vartheta_4^4)|_2 S &= -(\vartheta_4^4, \vartheta_3^4, \vartheta_2^4), \\ (\vartheta_2^4, \vartheta_3^4, \vartheta_4^4)|_2 T &= (-\vartheta_2^4, \vartheta_4^4, \vartheta_3^4). \end{aligned} \tag{32}$$

We refer the reader to Appendix A for the definition and properties of various modular objects used in the core of this article.

The quotient group $\text{SL}_2(\mathbb{Z})/\Gamma(2)$ is isomorphic to the permutation group S_3 , which acts on modular forms permutes $\vartheta_2^8, \vartheta_3^8$ and ϑ_4^8 . The Hauptmodul of $\Gamma(2)$, the Picard lambda function (which has weight zero), is given in terms of the Jacobi theta functions by

$$\lambda(\tau) = \frac{\vartheta_2^4(\tau)}{\vartheta_3^4(\tau)}. \tag{33}$$

The lambda function $\lambda(\tau)$ transforms under $\gamma \in \text{SL}_2(\mathbb{Z})$ as follows:

$$\begin{array}{c|cccccc} \gamma & 1 & S & T & ST & (ST)^2 & TST \\ \hline \lambda(\gamma\tau) & \lambda & 1-\lambda & \frac{\lambda}{\lambda-1} & \frac{\lambda-1}{\lambda} & \frac{1}{1-\lambda} & \frac{1}{\lambda} \end{array}. \tag{34}$$

The above transformations of the λ functions indeed show that the congruence group $\Gamma(2)$ decomposes the $\text{SL}_2(\mathbb{Z})$ group to the permutation group S_3 :

$$\text{SL}_2(\mathbb{Z})/\Gamma(2) = \langle 1, S, T, ST, (ST)^2, TST \rangle. \tag{35}$$

The fundamental domain $\Gamma(2)\backslash\mathbb{H}$ is made of the sum of the S_3 transformations of the fundamental domain $\mathcal{F}_{\text{SL}_2(\mathbb{Z})} = \text{SL}_2(\mathbb{Z})\backslash\mathbb{H}$:

$$\mathcal{F}_{\Gamma(2)} = \langle 1, S, T, ST, (ST)^2, TST \rangle \cdot \mathcal{F}_{\text{SL}_2(\mathbb{Z})}. \tag{36}$$

A representative of the six regions of the fundamental domain $\mathcal{F}_{\Gamma(2)}$ are given in Fig. 2 where they are labelled as (1, 6, 2, 3, 5, 4). The theta subgroup Γ_θ of $\text{SL}_2(\mathbb{Z})$ is defined as follows:

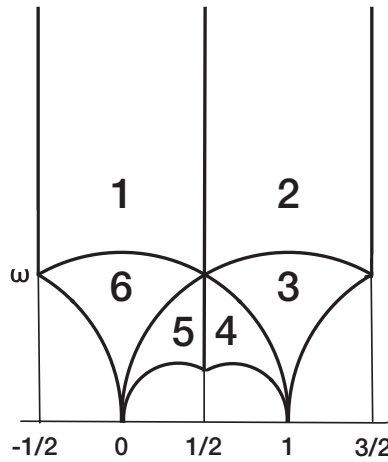

Fig. 2. Fundamental domain of $\Gamma(2)$.

$$\Gamma_\theta = \left\{ \gamma \in \text{SL}_2(\mathbb{Z}) \mid \gamma \equiv \begin{pmatrix} 1 & 0 \\ 0 & 1 \end{pmatrix} \text{ or } \begin{pmatrix} 0 & 1 \\ 1 & 0 \end{pmatrix} \pmod{2} \right\}. \tag{37}$$

The Hecke congruence subgroups of level two are defined as

$$\Gamma_0(2) = \left\{ \gamma \in \text{SL}_2(\mathbb{Z}) \mid \gamma \equiv \begin{pmatrix} * & * \\ 0 & * \end{pmatrix} \pmod{2} \right\}, \tag{38}$$

$$\Gamma^0(2) = \left\{ \gamma \in \text{SL}_2(\mathbb{Z}) \mid \gamma \equiv \begin{pmatrix} * & 0 \\ * & * \end{pmatrix} \pmod{2} \right\}. \tag{39}$$

One can easily see that at level two these coincide with the subgroups of unipotent elements modulo 2, namely $\Gamma_1(2)$ and $\Gamma^1(2)$. $\Gamma(2)$ is obviously a subgroup of $\Gamma_\theta, \Gamma^0(2), \Gamma_0(2)$. The index of $\Gamma_\theta, \Gamma_0(2)$ and $\Gamma^0(2)$ in $\text{SL}_2(\mathbb{Z})$ is 3. Moreover, one has the following indices:

$$\left[\text{SL}_2(\mathbb{Z}) : \Gamma_\theta \right] = 3, \quad \left[\Gamma_\theta : \Gamma(2) \right] = 2, \quad \left[\text{SL}_2(\mathbb{Z}) : \Gamma(2) \right] = 6. \tag{40}$$

We have the following quotients:

$$\begin{aligned} \text{SL}_2(\mathbb{Z})/\Gamma_\theta &= \langle 1, T, ST \rangle, & \Gamma_\theta/\Gamma(2) &= \langle 1, S \rangle, \\ \text{SL}_2(\mathbb{Z})/\Gamma^0(2) &= \langle 1, T, S \rangle, & \Gamma^0(2)/\Gamma(2) &= \langle 1, TST \rangle, \\ \text{SL}_2(\mathbb{Z})/\Gamma_0(2) &= \langle 1, S, (ST)^2 \rangle, & \Gamma_0(2)/\Gamma(2) &= \langle 1, T \rangle. \end{aligned} \tag{41}$$

The fundamental domains for these congruence subgroups are given by acting with the generators of the quotient spaces on the fundamental domain of $\text{SL}_2(\mathbb{Z})$, up to a proper identification of boundaries. A connected representative of these fundamental domains is drawn in Fig. 3. The spaces of the modular forms for these groups are simply spanned by combinations of Jacobi theta functions:

$$\begin{aligned} \mathcal{M}_{2k}(\Gamma_\theta) &= \text{span}\{(-\vartheta_2^4)^r \vartheta_4^{4s} + (-\vartheta_2^4)^s \vartheta_4^{4r}, r \leq s, r + s = k\}, \\ \mathcal{M}_{2k}(\Gamma^0(2)) &= \text{span}\{(-1)^{r+s} (\vartheta_3^{4r} \vartheta_4^{4s} + \vartheta_3^{4s} \vartheta_4^{4r}), r \leq s, r + s = k\}, \\ \mathcal{M}_{2k}(\Gamma_0(2)) &= \text{span}\{\vartheta_2^{4r} \vartheta_3^{4s} + \vartheta_2^{4s} \vartheta_3^{4r}, r \leq s, r + s = k\}. \end{aligned} \tag{42}$$

From the $\Gamma(2)$ weight 0 modular function $\lambda(\tau)$, one can form the Γ_θ Hauptmodul:

$$K(\tau) = \frac{16}{\lambda(1-\lambda)} - 24 = \frac{\vartheta_2^{12} + \vartheta_3^{12} + \vartheta_4^{12}}{2\eta^{12}} = \frac{\vartheta_3^{12}}{\eta^{12}} - 24$$

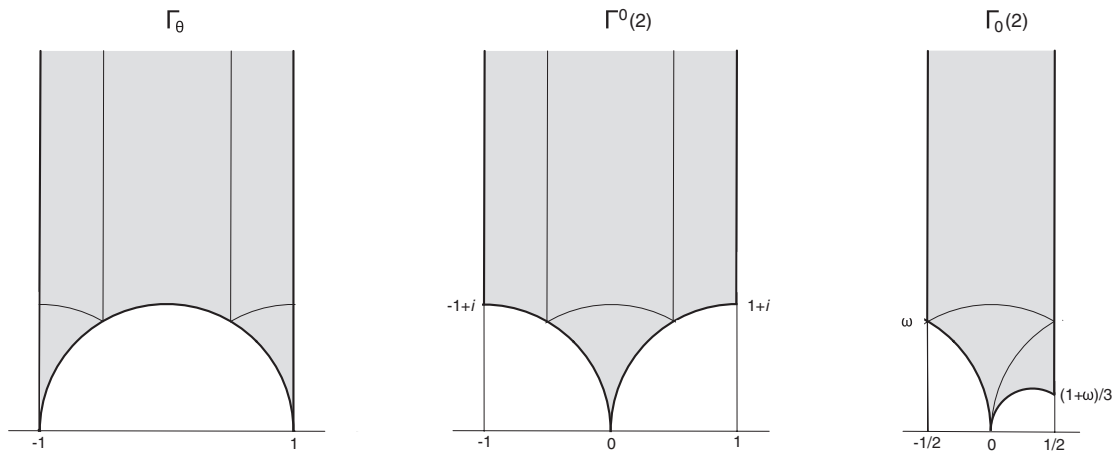

Fig. 3. Fundamental domains of $\Gamma_\theta, \Gamma^0(2)$ and $\Gamma_0(2)$.

$$= q^{-\frac{1}{2}} + 276q^{\frac{1}{2}} + 2048q + 11202q^{\frac{3}{2}} + 49152q^2 + 184024q^{\frac{5}{2}} + 614400q^3 + \dots \quad (43)$$

It is indeed invariant under S and T^2 and has played a fundamental role in the moonshine phenomena for the sporadic group Co_0 as the vacuum character of an $\mathcal{N} = 1$ supersymmetric conformal field theory (super VOA) [31].

The various modular functions λ, j, K satisfy the following simple identities:

$$\begin{aligned} \frac{1}{2\pi i} \frac{d}{d\tau} \lambda(\tau) &= \frac{1}{2} \vartheta_4^4 \lambda, \\ \frac{1}{2\pi i} \frac{d}{d\tau} K(\tau) &= -\frac{1}{2} (\vartheta_4^4 - \vartheta_2^4) (K(\tau) + 24), \\ \frac{1}{2\pi i} \frac{d}{d\tau} j(\tau) &= \frac{1}{2} (\vartheta_4^4 - \vartheta_2^4) \left(1 - \frac{3}{1 - \lambda(1 - \lambda)} \right) j(\tau). \end{aligned} \quad (44)$$

We will use the λ function to re-express the MLDEs in terms of the new variable $\tau \rightarrow \lambda(\tau)$. It so happens that in some nice situations, doing so will allow us to explicitly solve the ODE, hence providing a closed form expression of the characters. For instance, it is known that the MLDE (25) can be written in terms of λ and take the form

$$\left[\frac{d^2}{d\lambda^2} + \frac{2(1 - 2\lambda)}{3\lambda(1 - \lambda)} \frac{d}{d\lambda} + \frac{4\mu(1 - \lambda + \lambda^2)}{\lambda^2(1 - \lambda)^2} \right] f = 0. \quad (45)$$

which then can explicitly be solved in terms of the hypergeometric function ${}_2F_1$.

3.2. Valence formula for Γ_θ

Let us consider the Γ_θ valence formula for definiteness. The valence formula for $\Gamma_0(2)$ and $\Gamma^0(2)$ could be found similarly. The fundamental domain for Γ_θ is depicted in Fig. 3. With the S, T^2 generators leaving the fundamental domain invariant, one has to fold along the $\tau = 0$ vertical line, identifying the $\text{Re}(\tau) = \pm 1$ vertical line by T^2 transformation and the left and right half of the semicircle by S transformation. The fundamental domain $\mathcal{D}_{\Gamma_\theta}$ has two cusp points, at $i\infty$ and 1, and a single orbifold point $\tau = i$ of order two.

Table 3. Weight k (weak) modular forms of Γ_θ .

$f(\tau)$	$\frac{k}{4}$	$2v_\infty$	v_1	$\frac{1}{2}v_i$	v_{interior}
$\vartheta_4^4 - \vartheta_2^4$	$\frac{1}{2}$	0	0	$\frac{1}{2}$	0
ϑ_3^8	1	0	1	0	0
$\vartheta_2^4 \vartheta_4^4$	1	1	0	0	0
E_4	1	0	0	0	1 (at ω)
E_6	$\frac{3}{2}$	0	0	$\frac{1}{2}$	1 (at $1+i$)
$\vartheta_2^4 \vartheta_3^8 \vartheta_4^4$	2	1	1	0	0
$K(\tau) + 24$	0	-1	1	0	0
$K(\tau) - 40$	0	-1	0	1	0
$\Delta(\tau)$	3	2	1	0	0

Analogous to the $SL_2(\mathbb{Z})$ case, we consider a class of the functions $f : \mathbb{H} \rightarrow \mathbb{C}$ that f are holomorphic inside \mathbb{H} , at worst meromorphic at the cusps $i\infty$ and 1, and satisfy

$$(f|_k \gamma)(\tau) = \rho(\gamma)^{-1} (c\tau + d)^{-k} f(\gamma\tau) = f(\tau), \quad \forall \gamma \in \Gamma_\theta. \tag{46}$$

where $\rho : \Gamma_\theta \rightarrow U(1)$ is a possible phase. To derive a valence formula for Γ_θ , we are interested in the integration of df/f along the contour in the fundamental domain of Γ_θ as shown in Fig. 4. We follow the argument in the derivation of the valence formula for $SL_2(\mathbb{Z})$ in Sect. 2. The contour integration leads to the equalities

$$\begin{aligned}
 -\frac{1}{2\pi i} \oint d\tau \frac{\frac{d}{d\tau} f(\tau)}{f(\tau)} &= - \sum_{\substack{p \in SL_2(\mathbb{Z}) \setminus \mathbb{H} \\ p \neq i, 1, i\infty}} v_p(f) \\
 &= 2v_\infty(f) + v_1(f) + \frac{1}{2}v_i(f) - \frac{k}{4}.
 \end{aligned} \tag{47}$$

When the contour gets shrunk, it receives contributions only from the zeros of f lying on the interior region, that is, not a orbifold point or cusps. This is the first equality. The second one comes from the contour contributions. One can read off the origin of each term in the right-hand side of the above equation from the dashed line in Fig. 4. The contributions from the contour segments are as follows:

$$\begin{aligned}
 C_{EA} : 2v_\infty(f), \quad C_{BB'} + C_{DD'} &= v_1(f), \quad C_{CC'} : \frac{1}{2}v_i(f), \\
 C_{AB} + C_{D'E} : 0, \quad C_{BC} + C_{C'D} &: -\frac{k}{4},
 \end{aligned} \tag{48}$$

For $f \sim q^n$ near $i\infty$, $\log(f) \sim 2\pi in \log \tau$. The integration length of C_{EA} is two and so its contribution is $2v_\infty(f) = 2n$. At another cusp 1, the contribution becomes just v_1 . The structure of the zero and the contour at 1 just comes from the ST transformation of the $i\infty$ contour integration in $SL_2(\mathbb{Z})$. On orbifold points i the contribution gets only 1/2 fraction of $v_i(f)$ as one integrates over one half of 2π integration. On the arc C_{BC} and $C_{C'C}$, a point τ and its S-dual points $-\tau^{-1}$ are matched. One changes the variable $\tau \rightarrow -1/\tau$ on $C_{B'C}$ and uses the fact $f(-1/\tau) = \rho(S) \tau^k f(\tau)$ to get that the contribution from the contour $C_{B'C}$ is minus of that from the contour $C_{C'D}$ and $-k/4$. The factor 1/4 arises because the angle between 1 and i is one-fourth of 2π .

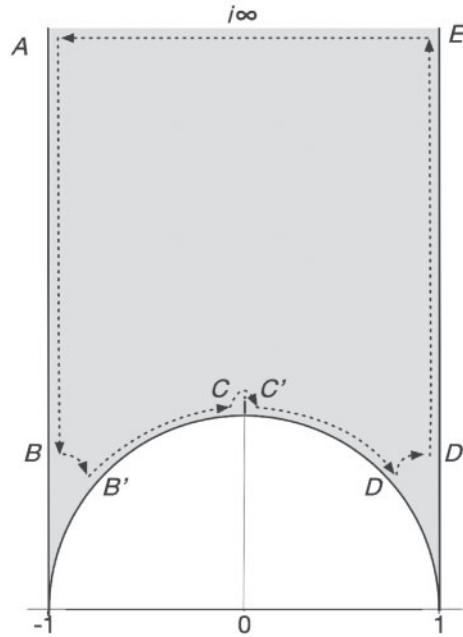

Fig. 4. Integration contour along the boundary of the fundamental domain of Γ_θ .

In short, we obtain the valence formula for Γ_θ as follows:

$$2v_{i\infty}(f) + v_1(f) + \frac{v_i(f)}{2} + \sum_{\substack{\tau \in \Gamma_\theta \setminus \mathbb{H} \\ \tau \neq i}} v_\tau(f) = \frac{k}{4}. \tag{49}$$

Table 3 is a check for the valence formula for modular forms of Γ_θ . As studied in Sect. 3.1, the space $M_k(\Gamma_\theta)$ of modular forms is generated by $(-\vartheta_2^4)^r \vartheta_4^{4s} + (-\vartheta_2^4)^s \vartheta_4^{4r}$, $0 \leq r \leq s$, $r + s = k$. The space $S_k(\Gamma_\theta)$ of cusp forms for Γ_θ is made of the modular forms of Γ_θ which vanish at cusps, $i\infty$ and 1, given by

$$S_{2k}(\Gamma_\theta) = \vartheta_2^4 \vartheta_3^8 \vartheta_4^4 M_{2k-8}(\Gamma_\theta). \tag{50}$$

The dimensions of M_{2k} and S_{2k} are given as follows:

$$\begin{aligned} \dim M_{2k}(\Gamma_\theta) &= \begin{cases} 1 + \lfloor \frac{k}{2} \rfloor, & k \geq 0 \\ 0, & k < 0, \end{cases} \\ \dim S_{2k}(\Gamma_\theta) &= \begin{cases} -1 + \lfloor \frac{k}{2} \rfloor, & k \geq 4 \\ 0, & k < 4. \end{cases} \end{aligned} \tag{51}$$

3.3. Modular linear differential equation for Γ_θ

Let us now see how to use the above valence formula in the context of fermionic RCFTs. For that purpose, we consider a fermionic RCFT which has a finite number of characters χ_i^{NS} , $i = 0, 1, \dots, N-1$ with conformal weight h_i . We repeat the argument for an MLDE of $\text{SL}_2(\mathbb{Z})$ in Sect. 2.2 for these N

characters in the NS sector to get the MLDE for Γ_θ :

$$\left[\mathcal{D}^N + \sum_{k=0}^{N-1} \phi_k \mathcal{D}^k \right] f^{\text{NS}} = 0. \tag{52}$$

The coefficient functions $\phi_k = (-1)^{N-k} W_k/W_N$ are the weight $2N - 2k$ rational functions of modular forms of Γ_θ . The Wronskian W_k here is given in terms of the NS sector characters χ_i^{NS} . We adopt the same strategy as in, e.g., studying or classifying MLDEs based on the order of poles of $\phi_k = (-1)^{N-k} W_k/W_N$. Since the characters χ_i^{NS} and hence W_k are always holomorphic inside the fundamental domain, the only possibility of introducing a pole is through the zeros of the denominator W_N . It is easy to check that W_N transforms as a (meromorphic) weight $N(N - 1)$ modular form of Γ_θ up to a possible overall phase. Therefore, we can safely apply the valence formula (49) to W_N .

Due to the very nature of characters, we are able to further simplify the formula. Notice that at $\tau = i\infty$, by definition χ_j^{NS} has the following asymptotic expansion:

$$\chi_j^{\text{NS}}|_{i\infty} = q^{-c/24+h_j^{\text{NS}}} (\text{const.} + \mathcal{O}(q)). \tag{53}$$

Taking the Serre derivative on χ_j^{NS} does not change their order at $i\infty$, so we learn that

$$W_N|_{i\infty} = q^{-Nc/24+\sum_j h_j^{\text{NS}}} (\text{const.} + \mathcal{O}(q)). \tag{54}$$

In other words, we have

$$v_{i\infty}(W_N) = -\frac{Nc}{24} + \sum_j h_j^{\text{NS}}. \tag{55}$$

Concerning the cusp at 1, a priori we need to find a suitable local coordinate to extract the leading order. However, there is a way to bypass this problem by noting the fact that 1 is mapped to $i\infty$ under the (ST^{-1}) transform. Then the local behaviour of χ_j^{NS} around 1 is equivalent to that of $ST^{-1}(\chi_j^{\text{NS}}) \sim \chi_j^{\text{R}}$ around $i\infty$. Thus the Wronskian of NS characters near $\tau = 1$ becomes that of R characters near $\tau = i\infty$:

$$W_N|_1 \sim q^{-Nc/24+\sum_j h_j^{\text{R}}} (1 + \mathcal{O}(q)). \tag{56}$$

Immediately, we see that

$$v_1(W_N) = -\frac{Nc}{24} + \sum_j h_j^{\text{R}}. \tag{57}$$

Mimicking what was done in Ref. [8] and also in Eq. (24), if we define $l/2$ to be the ‘‘number’’ of zeros inside the fundamental domain, the valence formula (49) gives us then the following relation:

$$-\frac{Nc}{8} + 2 \sum_j h_j^{\text{NS}} + \sum_j h_j^{\text{R}} + \frac{\ell}{2} = \frac{N(N - 1)}{4}, \tag{58}$$

where the contribution from zeros is given as

$$\frac{\ell}{2} \equiv \frac{1}{2} v_i(W) + \sum_{\substack{\tau \in \Gamma_\theta \backslash \mathbb{H} \\ \tau \neq i}} v_\tau(W). \tag{59}$$

For a given fermionic RCFT with known c, h_j^{NS} and h_j^{R} , the value of the zero determines the structure of the MLDE satisfied by the characters in the NS sector. In this work, we will focus on the case where $\ell = 0$. In this case, the coefficient functions ϕ_k of the MLDE for Γ_θ become the modular functions of $M_{2N-2k}(\Gamma_\theta)$. We explore the possible values of c, h_j^{NS} and h_j^{R} , whose characters have the non-negative integer $q^{1/2}$ -expansion coefficient. For the conformal characters in the NS sector, there always exists the unique *vacuum* character with zero conformal weight $h = 0$ and $q^{1/2}$ expansion:

$$\begin{aligned} \chi_0^{\text{NS}} &= q^{-\frac{c}{24}} \left(1 + a_1 q^{\frac{1}{2}} + a_2 q + a_3 q^{\frac{3}{2}} + a_4 q^2 + \dots \right) \\ &= q^{-\frac{c}{24}} \left[1 + \sum_{n=1}^{\infty} a_n q^{\frac{n}{2}} \right]. \end{aligned} \tag{60}$$

The MLDE for $\widetilde{\text{NS}}, \text{R}$ sectors can be obtained by just making a T and S transformation of the MLDE for the NS sector. The modular forms ϕ_k would transform accordingly.

Before exploring the solutions of MLDE, let us compare the bosonic and fermionic valence formulas (23) and (58). If we start with N characters in the NS sector, we can bosonize and get $3N$ characters by combining all NS, $\widetilde{\text{NS}}$, and R characters. By a linear combination of χ_a^{NS} and $\chi_a^{\widetilde{\text{NS}}}$ we get two characters with conformal weight h_a for the sum and $h_a + s_a$ for the difference, where s_a is a positive half-integer, say, $1/2$ or $3/2$, in our case. Thus we could use the bosonic MLDE for the $3N$ characters with $h_a^{\text{NS}}, h_a^{\text{NS}} + s_a$ and h_a^{R} with the number of zeros ℓ_b . For simplicity, we are assuming that all $3N$ characters are linearly independent. Then two valence formulas imply a consistency condition,

$$\frac{\ell_b}{6} = \frac{\ell_f}{2} + \frac{N^2}{2} - \sum_a s_a. \tag{61}$$

As we consider the solutions of MLDE for the fermionic RCFT in the q -expansion, we can read s_a trivially. The above relation then provides the information on the ℓ_b , i.e., the pole structure of the coefficient functions for MLDE of bosonic $3N$ characters.

4. Fermionic first-order MLDE

As a warm-up exercise, we consider the fermionic RCFT whose torus partition function for each spin structure can be holomorphically factorized. That is to say, the theory has a single character in each sector. For convenience, let us focus on the NS sector. The vacuum character $f_0^{\text{NS}}(\tau) \sim q^{-c/24}(1 + \dots)$ then becomes a solution to the first-order MLDE below

$$\left[\mathcal{D} + \phi_0(\tau) \right] f^{\text{NS}}(\tau) = 0, \tag{62}$$

where $\phi_0(\tau)$ is the Γ_θ modular form of weight two. Restricting our attention to the case $l = 0$, $\phi_0(\tau)$ can be generated by $(-\vartheta_2^4(\tau) + \vartheta_4^4(\tau))$ since the space $M_2(\Gamma_\theta)$ is one-dimensional. Therefore the first-order MLDE of our interest takes the form of

$$\left[D_\tau + \mu (-\vartheta_2^4(\tau) + \vartheta_4^4(\tau)) \right] f^{\text{NS}} = 0. \tag{63}$$

Note that its T and S transformations lead to the first-order MLDE for $\Gamma^0(2)$ and $\Gamma_0(2)$:

$$\left[D_\tau - \mu (\vartheta_3^4(\tau) + \vartheta_4^4(\tau)) \right] f^{\widetilde{\text{NS}}} = 0,$$

$$\left[D_\tau + \mu (\vartheta_2^4(\tau) + \vartheta_3^4(\tau)) \right] f^R = 0. \tag{64}$$

To have a conformal character $f_0^{\text{NS}} \sim q^{-c/24}(1 + \dots)$, one can determine the coefficient μ to be $\mu = c/12$. With the help of (44), Eq. (63) can be rewritten in terms of the $\lambda(\tau)$ variable as

$$\left[\frac{d}{d\lambda} + \frac{c}{12} \frac{1 - 2\lambda}{\lambda(1 - \lambda)} \right] f^{\text{NS}} = 0. \tag{65}$$

The solution is simply given by

$$f_0^{\text{NS}}(\lambda) = \left[\frac{16}{\lambda(1 - \lambda)} \right]^{\frac{c}{12}} = (K + 24)^{\frac{c}{12}}. \tag{66}$$

Demanding the solution to have non-negative integer coefficients for the q -expansion leads to $c = N/2$ for a positive integer N . This is consistent with the fact that the chiral central charge of a fermionic CFT has to be half-integral. This is because the $(2 + 1)$ -dimensional fermionic gravitational Chern–Simons coupling can cancel certain (anomalous) $U(1)$ phases that arise from the modular transformation of partition functions of fermionic CFTs with $c_L - c_R \in \mathbb{Z}/2$.

When $N = 1$, one can see that f_0^{NS} is nothing but the NS partition function of a single free Majorana–Weyl fermion,

$$\psi^{\text{NS}} = \left[\frac{16}{\lambda(1 - \lambda)} \right]^{\frac{1}{24}} = \sqrt{\frac{\vartheta_3}{\eta}}. \tag{67}$$

The other partition function for different spin structures can be obtained by acting T and S on ψ^{NS} ;

$$\begin{aligned} T : \psi^{\text{NS}} &\longleftrightarrow e^{-\pi i/24} \psi^{\widetilde{\text{NS}}} = e^{-\pi i/24} \sqrt{\frac{\vartheta_4}{\eta}}, \\ S : \psi^{\widetilde{\text{NS}}} &\longleftrightarrow \psi^{\text{R}} = \sqrt{\frac{\vartheta_2}{\eta}}. \end{aligned} \tag{68}$$

Note also that the characters of a free Majorana–Weyl fermion are related to the characters of the Ising model as follows

$$\begin{aligned} \psi^{\text{NS}} &= \chi_0^{\text{Ising}} + \chi_{\frac{1}{2}}^{\text{Ising}}, \\ \psi^{\widetilde{\text{NS}}} &= \chi_0^{\text{Ising}} - \chi_{\frac{1}{2}}^{\text{Ising}}, \\ \psi^{\text{R}} &= \sqrt{2} \chi_{\frac{1}{16}}^{\text{Ising}}. \end{aligned} \tag{69}$$

Therefore, the solution (67) can be identified with the NS partition function of N copies of free Majorana–Weyl fermions,

$$f_0^{\text{NS}}(\tau) = \left(\psi^{\text{NS}}(\tau) \right)^N, \tag{70}$$

with the identities

$$(\psi^{\text{NS}})^{24} = K(\tau) + 24, \quad (\psi^{\widetilde{\text{NS}}})^{24} = -K(\tau + 1) + 24, \quad (\psi^{\text{R}})^{24} = -K\left(-\frac{1}{\tau} + 1\right) + 24. \tag{71}$$

5. Fermionic second-order MLDE

5.1. The second-order MLDE

In this section, we consider the fermionic RCFT with two characters in each sector. Let us first focus on the NS sector. The characters for the vacuum and primary state of conformal weight h^{NS} have a series expansion

$$\begin{aligned} f_0^{\text{NS}}(\tau) &= q^{-\frac{c}{24}} \left(1 + a_1 q^{\frac{1}{2}} + a_2 q + a_3 q^{\frac{3}{2}} + a_4 q^2 + \dots \right), \\ f_1^{\text{NS}}(\tau) &= q^{h^{\text{NS}} - \frac{c}{24}} \left(b_0 + b_1 q^{\frac{1}{2}} + b_2 q + b_3 q^{\frac{3}{2}} + b_4 q^2 + \dots \right), \end{aligned} \tag{72}$$

and they are independent solutions of the second-order MLDE of the form

$$\left[\mathcal{D}^2 + \phi_1(\tau)\mathcal{D} + \phi_0(\tau) \right] f_j^{\text{NS}}(\tau) = 0, \quad j = 0, 1. \tag{73}$$

We restrict our attention to the zero-pole case $\ell = 0$, where the coefficients ϕ_0 and ϕ_1 are spanned by Γ_θ modular forms of weight four and two, respectively. The weight two modular form $M_2(\Gamma_\theta)$ is one-dimensional and generated by $-\vartheta_2^4 + \vartheta_4^4$. The space of the weight four modular form $M_4(\Gamma_\theta)$ is two-dimensional and its basis is chosen to be ϑ_3^8 and E_4 . Therefore, the second-order MLDE for NS sector takes the expression

$$\left[\mathcal{D}^2 + \mu_1 (-\vartheta_2^4(\tau) + \vartheta_4^4(\tau)) \mathcal{D} + \mu_2 \vartheta_3^8 + \mu_3 E_4 \right] f^{\text{NS}}(\tau) = 0, \tag{74}$$

where μ_1, μ_2 and μ_3 are three independent coefficients. We will mainly focus on the solutions of Eq. (74) which have the non-negative integer coefficients in the q -expansion. Note that the first term of the vacuum solution should be given by $q^{-c/24}$ due to the uniqueness of the vacuum state. On the other hand, there is an ambiguity for the normalization of the primary solution denoted by b_0 in Eq. (72). We will show that the normalization b_0 for the NS sector solution can be fixed with the help of analytic expression of the S -matrix.

The MLDE for $\widetilde{\text{NS}}$ and R sectors can be obtained from Eq. (74) by applying T and ST transformation. Explicitly, the differential equations are given by

$$\begin{aligned} \left[\mathcal{D}^2 + \mu_1 (\vartheta_3^4(\tau) + \vartheta_2^4(\tau)) \mathcal{D} + \mu_2 \vartheta_4^8(\tau) + \mu_3 E_4(\tau) \right] f^{\widetilde{\text{NS}}}(\tau) &= 0 \quad \text{for } \widetilde{\text{NS}} \text{ sector,} \\ \left[\mathcal{D}^2 - \mu_1 (\vartheta_3^4(\tau) + \vartheta_4^4(\tau)) \mathcal{D} + \mu_2 \vartheta_2^8(\tau) + \mu_3 E_4(\tau) \right] f^{\text{R}}(\tau) &= 0 \quad \text{for R sector,} \end{aligned} \tag{75}$$

which are consistent with the valence formula. In the case of $\mu_1 = \mu_2 = 0$, the above three MLDEs reduce to the second-order MLDE for $\text{SL}_2(\mathbb{Z})$, the solutions of which were discussed in Sect. 2.2. Thus we restrict our study to the cases where at least one of μ_1, μ_2 is non-zero.

Our strategy of solving the NS sector MLDE is to ask if the characters of the series form (72) are solutions of Eq. (74) in every order of q . In addition, we demand the coefficients of the series expansion to be non-negative integers. Let us choose the input to be central charge c , weight of the primary h^{NS} , and $a_1 \geq 0$, where a_1 is the coefficient of the $q^{1/2}$ term in the vacuum character. For non-zero a_1 , the corresponding theory contains primaries of dimension $1/2$ and spin $1/2$, i.e., free fermions. (See, for instance, Ref. [41].) Once we require the NS sector characters to satisfy the MLDE for Γ_θ , the coefficients μ_1, μ_2, μ_3 are determined by inputting parameters (c, h, a_1) as

follows:

$$\begin{aligned} \mu_1 &= \frac{c - 12h^{\text{NS}} + 2}{12}, \\ \mu_2 &= -\frac{c(c - 12h^{\text{NS}} + 2) + 3a_1(1 - 2h^{\text{NS}})}{192}, \\ \mu_3 &= \frac{2c(2c - 30h^{\text{NS}} + 3) + 9a_1(1 - 2h^{\text{NS}})}{576}. \end{aligned} \tag{76}$$

Now let us move our attention to the R sector. The two characters of the R sector have series expansions of the form

$$\begin{aligned} f_0^{\text{R}}(\tau) &= q^{h_-^{\text{R}} - \frac{c}{24}} (a'_0 + a'_1 q + a'_2 q^2 + a'_3 q^3 + a'_4 q^4 + \dots), \\ f_1^{\text{R}}(\tau) &= q^{h_+^{\text{R}} - \frac{c}{24}} (b'_0 + b'_1 q + b'_2 q^2 + b'_3 q^3 + b'_4 q^4 + \dots), \end{aligned} \tag{77}$$

where h_{\pm}^{R} denote the weights of two primaries in the R sector. Without loss of generality, we assume $h_+^{\text{R}} \geq h_-^{\text{R}}$, i.e., h_-^{R} is the Ramond vacuum weight. With the help of Eq. (76), one can show that the weights h_{\pm}^{R} of the R sector are determined from the MLDE (75) as below,

$$h_{\pm}^{\text{R}} = \frac{1}{8} \left(2 + c - 8h^{\text{NS}} \pm \sqrt{4(1 - 4h^{\text{NS}})^2 + (2c - a_1)(1 - 2h^{\text{NS}})} \right), \tag{78}$$

and the weights h_{\pm}^{R} should be a rational number as far as we consider the RCFT. Note that the valence formula (58) is satisfied trivially with Eq. (78). When we assume the resulting theory has supersymmetry, there is a unitarity bound

$$h^{\text{R}} \geq \frac{c}{24} \tag{79}$$

for the R sector weights which leads to the constraint on the initial data (c, h^{NS}, a_1) ,

$$\mu_3 \sim 2c(2c - 30h^{\text{NS}} + 3) + 9a_1(1 - 2h^{\text{NS}}) \geq 0. \tag{80}$$

For a specific case where $a_1 = 0$, or $h^{\text{NS}} = 1/2$, this bound takes a simpler form:

$$\begin{cases} c \geq 15h^{\text{NS}} - \frac{3}{2} & \text{for } a_1 = 0, \\ c \geq 6 & \text{for } h^{\text{NS}} = \frac{1}{2}. \end{cases} \tag{81}$$

Let us further comment on the RCFT with supersymmetry. A necessary condition for a fermionic RCFT to have supersymmetry is that there is at least one weight-3/2 supersymmetry current as a vacuum descendant. Such supersymmetry currents contribute to $a_3 q^{3/2}$ in the NS vacuum character. If a supersymmetric RCFT further saturates a unitarity bound (79), the RCFT has the supersymmetric ground states. Otherwise one can say that the supersymmetry is spontaneously broken. For this reason, we call $h_-^{\text{R}} = c/24$ the BPS condition. When the BPS condition is satisfied and $h^{\text{NS}} \neq 1/2$, one can fix h_+^{R} and a_1 in terms of c and h^{NS} as follows:

$$h_-^{\text{R}} = \frac{c}{24}, \quad h_+^{\text{R}} = \frac{5c}{24} + \frac{1}{2} - 2h^{\text{NS}}, \quad 2c(2c - 30h^{\text{NS}} + 3) + 9a_1(1 - 2h^{\text{NS}}) = 0. \tag{82}$$

We will discuss some examples of solutions that violate the unitarity bound, and thus cannot be considered as the characters for a supersymmetric RCFT, later.

5.2. Solutions of the second-order MLDE

Let us reformulate the second-order MLDEs in terms of the $\lambda(\tau)$ variable to find a closed-form solution;

$$\begin{aligned} & \left[\frac{d^2}{d\lambda^2} + \frac{2(1+3\mu_1)(1-2\lambda)}{3\lambda(1-\lambda)} \frac{d}{d\lambda} + \frac{4(\mu_2+\mu_3)-4\mu_3\lambda(1-\lambda)}{\lambda^2(1-\lambda)^2} \right] f^{\text{NS}}(\lambda) = 0, \\ & \left[\frac{d^2}{d\lambda^2} + \frac{2(1-2\lambda)+6\mu_1(1+\lambda)}{3\lambda(1-\lambda)} \frac{d}{d\lambda} + \frac{4(\mu_2+\mu_3)-4\mu_3\lambda(1-\lambda)}{\lambda^2(1-\lambda)^2} \right] f^{\widetilde{\text{NS}}}(\lambda) = 0, \\ & \left[\frac{d^2}{d\lambda^2} + \frac{2(1-2\lambda)+6\mu_1(\lambda-2)}{3\lambda(1-\lambda)} \frac{d}{d\lambda} + \frac{4(\mu_2+\mu_3)-4\mu_3\lambda(1-\lambda)}{\lambda^2(1-\lambda)^2} \right] f^{\text{R}}(\lambda) = 0. \end{aligned} \tag{83}$$

We obtain the MLDE for $f^{\widetilde{\text{NS}}}(\lambda)$ and $f^{\text{R}}(\lambda)$ by performing T and ST transformations on the MLDE for $f^{\text{NS}}(\lambda)$. When $h^{\text{NS}} \neq 1/2$, the solutions can be expressed in terms of the hypergeometric function as follows:

$$\begin{aligned} f_0^{\text{NS}}(\lambda) &= 2^{\frac{c}{3}} \lambda^{-\frac{c}{12}} (1-\lambda)^{-\frac{c}{12}} {}_2F_1(\beta^+, \beta^-; 1-2h^{\text{NS}}; \lambda), \\ f_1^{\text{NS}}(\lambda) &= b_0 2^{\frac{c}{3}-8h^{\text{NS}}} \lambda^{2h^{\text{NS}}-\frac{c}{12}} (1-\lambda)^{-\frac{c}{12}} {}_2F_1(\beta^+ + 2h^{\text{NS}}, \beta^- + 2h^{\text{NS}}; 1+2h^{\text{NS}}; \lambda), \end{aligned} \tag{84}$$

where b_0 denotes a normalization constant of the non-vacuum character and

$$\beta^\pm = \frac{1}{4} \left(2 - 8h^{\text{NS}} \pm \sqrt{4 - a_1 + 2c - 32h^{\text{NS}} + 2a_1h^{\text{NS}} - 4ch^{\text{NS}} + 64(h^{\text{NS}})^2} \right). \tag{85}$$

From the known identities of the hypergeometric functions, one can see that Eq. (84) transforms under the S transformation as

$$\begin{pmatrix} f_0^{\text{NS}}(1-\lambda) \\ f_1^{\text{NS}}(1-\lambda) \end{pmatrix} = \begin{pmatrix} \frac{\Gamma(1-2h^{\text{NS}})\Gamma(2h^{\text{NS}})}{\Gamma(1-2h^{\text{NS}}-\beta^+)\Gamma(1-2h^{\text{NS}}-\beta^-)} & \frac{2^{8h^{\text{NS}}}}{b_0} \frac{\Gamma(1-2h^{\text{NS}})\Gamma(-2h^{\text{NS}})}{\Gamma(\beta^+)\Gamma(\beta^-)} \\ \frac{b_0}{2^{8h^{\text{NS}}}} \frac{\Gamma(1+2h^{\text{NS}})\Gamma(2h^{\text{NS}})}{\Gamma(1-\beta^+)\Gamma(1-\beta^-)} & \frac{\Gamma(1+2h^{\text{NS}})\Gamma(-2h^{\text{NS}})}{\Gamma(\beta^++2h^{\text{NS}})\Gamma(\beta^-+2h^{\text{NS}})} \end{pmatrix} \begin{pmatrix} f_0^{\text{NS}}(\lambda) \\ f_1^{\text{NS}}(\lambda) \end{pmatrix}. \tag{86}$$

The derivation of Eqs. (84) and (86) was inspired by Ref. [42], and we briefly review it in Appendix B for completeness. Whenever we encounter zeros or poles in the denominator or numerator, a careful limit has to be taken.

For the case of $h^{\text{NS}} = 1/2$, the MLDE takes a form of

$$\left[\lambda^2(1-\lambda^2) \frac{d^2}{d\lambda^2} + \frac{c\lambda(1-\lambda)(1-2\lambda)}{6} \frac{d}{d\lambda} + \left(\frac{c(c-12)}{144} - \frac{1}{36}c(c-6)\lambda(1-\lambda) \right) \right] f^{\text{NS}}(\lambda) = 0$$

and there are two independent solutions for the above differential equation:

$$g_1(\lambda) = (\lambda(1-\lambda))^{-\frac{c}{12}}, \quad g_2(\lambda) = \lambda (\lambda(1-\lambda))^{-\frac{c}{12}}. \tag{87}$$

Thus any NS sector character of a two-character RCFT with $h^{\text{NS}} = 1/2$ should be written as a combination of $g_1(\lambda)$ and $g_2(\lambda)$.

The structure of the NS sector partition function can be fixed by the S -matrix presented in Eq. (86). More precisely, the NS sector partition function takes a form of

$$Z^{\text{NS}}(\tau, \bar{\tau}) = |f_0^{\text{NS}}(\lambda)|^2 + \mathcal{M} |f_1^{\text{NS}}(\lambda)|^2, \tag{88}$$

where \mathcal{M} denote the degeneracy of the NS primary states. Note that the multiplicity \mathcal{M} can be determined from the S -matrix as

$$S^T \cdot \text{diag}(1, \mathcal{M}) \cdot S = \text{diag}(1, \mathcal{M}). \tag{89}$$

With the help of the identity of the hypergeometric function

$${}_2F_1(\alpha_1, \alpha_2; \alpha_3; \lambda) = (1 - \lambda)^{-\alpha_1} {}_2F_1\left(\alpha_1, \alpha_3 - \alpha_2; \alpha_3; \frac{\lambda}{\lambda - 1}\right), \tag{90}$$

we find the analytic form of the $\widetilde{\text{NS}}$ sector solutions that work for $h^{\text{NS}} \neq 1/2$:

$$\begin{aligned} f_0^{\widetilde{\text{NS}}}(\lambda) &= 2^{\frac{c}{3}} \lambda^{-\frac{c}{12}} (1 - \lambda)^{\frac{c}{6} + \beta^+} {}_2F_1(\beta^+, 1 - 2h^{\text{NS}} - \beta^-; 1 - 2h^{\text{NS}}; \lambda), \\ f_1^{\widetilde{\text{NS}}}(\lambda) &= b_0 2^{\frac{c}{3} - 8h^{\text{NS}}} \lambda^{2h^{\text{NS}} - \frac{c}{12}} (1 - \lambda)^{\beta^+ + \frac{c}{6}} {}_2F_1(\beta^+ + 2h^{\text{NS}}, 1 - \beta^-; 1 + 2h^{\text{NS}}; \lambda). \end{aligned} \tag{91}$$

One can then express the partition function of the $\widetilde{\text{NS}}$ and R sectors in terms of the $\widetilde{\text{NS}}$ sector characters $f_0^{\widetilde{\text{NS}}}(\lambda)$ and $f_1^{\widetilde{\text{NS}}}(\lambda)$. Explicitly,

$$\begin{aligned} Z^{\widetilde{\text{NS}}}(\tau, \bar{\tau}) &= |f_0^{\widetilde{\text{NS}}}(\lambda)|^2 + \mathcal{M} |f_1^{\widetilde{\text{NS}}}(\lambda)|^2, \\ Z^{\text{R}}(\tau, \bar{\tau}) &= |f_0^{\widetilde{\text{NS}}}(1 - \lambda)|^2 + \mathcal{M} |f_1^{\widetilde{\text{NS}}}(1 - \lambda)|^2 = \mathcal{M}_1 |f_0^{\text{R}}(\lambda)|^2 + \mathcal{M}_2 |f_1^{\text{R}}(\lambda)|^2, \end{aligned} \tag{92}$$

where \mathcal{M}_1 and \mathcal{M}_2 are related to the degeneracy of two characters in the R sector. The q -expansion of characters are presented in Appendix C.

Let us now describe how we find the initial values (c, h^{NS}, a_1) which generate the solutions $f_0^{\text{NS}}(\tau)$ and $f_1^{\text{NS}}(\tau)$ as the q -series with the non-negative integer coefficients. Our approach is first to focus on the vacuum character $f_0^{\text{NS}}(\tau)$ by taking the series expansion of Eq. (84). One can survey the solutions of MLDEs which have rational $0 < c = \frac{p'}{p} \leq 24$ and non-negative integers for the coefficients a_n in Eq. (72). For instance, when we impose the BPS condition in the R sector, coefficient a_2 of the vacuum character is given as

$$a_2 = \frac{4c^2 - 68ch^{\text{NS}} - 4ca_1 + 4c + 2h^{\text{NS}}a_1^2 + 32h^{\text{NS}}a_1 - a_1^2}{4(h^{\text{NS}} - 1)}, \tag{93}$$

and it should be non-negative integer for a lot of positive rational numbers $c = p'/p$ and $h^{\text{NS}} = (r/s) < 1$. Assuming the upper bound on the denominators $p \leq p^*, s \leq s^*$ and the spin half current $a_1 \leq a_1^*$, we search for values (c, h^{NS}, a_1) that make a_2 a non-negative integer.

Alternatively, one can choose the initial data to be (c, a_2, a_1) and check a_3 being integral and non-negative for rational $0 < c = (p'/p) < 24$ with upper bounds on the denominator, i.e., $p \leq 12$. Then we find the initial data that furnishes non-negative integer a_3 with a_2 in the range $0 \leq a_2 \leq 10^6$. As an illustrative example, let us consider the case of $a_1 = 0$. Then the vacuum solution takes a form of

$$f_0^{\text{NS}}(\tau) = q^{-\frac{c}{24}} \left(1 + a_2 q + \left(\frac{8(a_2 + c)(a_2(c - 10) + c(5c + 22))}{3(a_2 + c(49 - 2c))} \right) q^{\frac{3}{2}} + \dots \right), \tag{94}$$

and the coefficients a_n for $n \geq 4$ are in general the rational function of two parameters a_2 and c . Here we demand at least one $a_{2\ell+1} \neq 0$ for $\ell \in \mathbb{Z}_{>0}$ to obtain the fermionic characters. Then we search the values of c and a_2 which give us the series with non-negative integer coefficients.

Table 4. Classification for the solutions of the second-order MLDE. The $c = 6$ solution in BPS type-I and non-BPS II are the same, as they satisfy both the BPS condition and $h^{\text{NS}} = 1/2$.

Type	Property	Central charge c
BPS, I	$h_-^{\text{R}} = \frac{c}{24}, a_1 = 0$	$1, \frac{9}{4}, 6, \frac{39}{4}, 11, 12$
BPS, II	$h_-^{\text{R}} = \frac{c}{24}, a_1 \neq 0$	$\frac{3}{4}, \frac{3}{2}, 3, 6, 9, \frac{21}{2}, \frac{45}{4}, 12$
Non-BPS, I	$h_-^{\text{R}} > \frac{c}{24}, h^{\text{NS}} \neq \frac{1}{2}$	$\frac{7}{10}, \frac{133}{10}, \frac{91}{5}, \frac{102}{5}, 21, \frac{85}{4}, 22, \frac{114}{5}$
Non-BPS, II	$h_-^{\text{R}} > \frac{c}{24}, h^{\text{NS}} = \frac{1}{2}$	$\frac{9}{2}, 5, \frac{11}{2}, 6, \frac{13}{2}, 7, \frac{15}{2}$
Non-BPS, III	One-parameter family	16
Non-BPS, IV	Single-character	$\frac{17}{2}, 9, \frac{19}{2}, 10, \dots, \frac{47}{2}$

Following the process described above, our next goal is to find the solutions of the second-order MLDE and classify them. We first divide the possible solutions of MLDE into two types: the BPS solution and the non-BPS solution. For the BPS solution type, we explore the cases of both $a_1 = 0$ and $a_1 \neq 0$. For the non-BPS type, we work out only the case with $a_1 = 0$. In total, there are six types of solutions, and their characteristic profiles are presented in Table 4. The detailed descriptions for each type will be given below, while the list of solutions can be found in Appendix C.¹

5.3. BPS solutions

5.3.1. BPS type I: Supersymmetric BPS pairs

Let us discuss the class of solutions whose R sector ground state saturates the unitarity bound $h_-^{\text{R}} = c/24$, i.e., the ground state of the supersymmetric theory preserves the supersymmetry. In this subsection, we first focus on the case of $a_1 = 0$. Sensible solutions appear for the six central charge values of $c = 1, 9/4, 6, 39/4, 11, 12$ and they are listed in Table 5. For the solutions in this type, the NS sector weight is given by $h^{\text{NS}} = (2c + 3)/30$. On the other hand, the R sector weights read $h_-^{\text{R}} = c/24$ and $h_+^{\text{R}} = 3(c + 4)/40$. The explicit q -series of the solutions can be found in Table C1 and Table C2 in Appendix C.

Fermionic RCFT with $c = 1$ The solution with $c = 1$ can be expressed in terms of the characters of the $\mathcal{N} = 1$ supersymmetric minimal models. We denote the unitary supersymmetric minimal model by $\mathcal{SM}(\ell + 2, \ell)$ where the central charge is given by

$$c = \frac{3}{2} \left(1 - \frac{8}{\ell(\ell + 2)} \right), \quad \ell = 2, 3, \dots \tag{95}$$

¹ Thus far we have expressed MLDEs in terms of the covariant Serre derivative $\mathcal{D}_k = (1/2i\pi)(d/d\tau) - (k/12)E_2$. However, for Γ_θ the most generic modular covariant derivative is given by $\mathcal{D}_k = (1/2i\pi)(d/d\tau) - (k/12)(E_2 + \alpha(\vartheta_2^4(\tau) - \vartheta_4^4(\tau)))$ with $\alpha \in \mathbb{C}$. With the choice of connection $\alpha = (c/2) - 6h^{\text{NS}} + 1$, one can show that Eq. (74) is equivalent to

$$\left\{ \tilde{\mathcal{D}}_0^2 - \frac{c(1 + 6h^{\text{NS}})}{288} E_4 + \frac{c(\frac{c}{2} - 6h^{\text{NS}} + 1)}{288} (\vartheta_2^4(\tau) - \vartheta_4^4(\tau))^2 \right\} \chi = 0.$$

The deformation α in the covariant derivative also precisely appears in front of the last term. Therefore this second-order MLDE can be viewed in some sense as a direct generalization of the Kaneko–Zagier equation. Indeed, the standard Deligne–Cvitanovic exceptional series is reproduced as a particular case of our equation, for which α is simply set to zero, namely when $c = 12h^{\text{NS}} - 2$.

Table 5. The six solutions of BPS type I. Here \mathcal{M} denotes the degeneracy of the non-vacuum primary. When $\mathcal{M} = 1$, the S -matrix is symmetric otherwise one should find the extended S -matrix for the consistent fusion rule algebra. The bracket means that the corresponding theory is effectively a single character theory, appearing as a solution to the second-order MLDE, with an artificial second solution.

c	1	$\frac{9}{4}$	6	$\frac{39}{4}$	11	12
h^{NS}	$\frac{1}{6}$	$\frac{1}{4}$	$\frac{1}{2}$	$\frac{3}{4}$	$\frac{5}{6}$	[1]
h^R	$\frac{1}{24}, \frac{3}{8}$	$\frac{3}{32}, \frac{15}{32}$	$\frac{1}{4}, \frac{3}{4}$	$\frac{13}{32}, \frac{33}{32}$	$\frac{11}{24}, \frac{9}{8}$	$\frac{1}{2}, [1]$
\mathcal{M}	2	1	15	1	2	[0]

The partition function of a unitary supersymmetric minimal model can be expressed by the characters $\chi_{m,n}^{NS}$ and $\chi_{m,n}^R$ [43];

$$\chi_{m,n}^{NS}(\tau; \ell) = \zeta_{m,n}^k(q) \prod_{\ell=1}^{\infty} \left(\frac{1 + q^{\ell - \frac{1}{2}}}{1 - q^\ell} \right), \quad \chi_{m,n}^R(\tau; \ell) = \zeta_{m,n}^k(q) q^{\frac{1}{16}} \prod_{\ell=1}^{\infty} \left(\frac{1 + q^{\ell - \frac{1}{2}}}{1 - q^\ell} \right), \quad (96)$$

where

$$\begin{aligned} \zeta_{m,n}^k(q) &= \sum_{\alpha \in \mathbb{Z}} \left(q^{\gamma_{m,n}^k(\alpha)} - q^{\delta_{m,n}^k(\alpha)} \right), \\ \gamma_{m,n}^k(\alpha) &= \frac{(2k(k+1)\alpha - m(k+2) + pk)^2 - 4}{8k(k+2)}, \\ \delta_{m,n}^k(\alpha) &= \frac{(2k(k+1)\alpha + m(k+2) + pk)^2 - 4}{8k(k+2)}. \end{aligned} \quad (97)$$

For the $\mathcal{N} = 1$ supersymmetric minimal model, the conformal weights are allowed to have the values

$$h_{m,n} = \frac{[(\ell + 2)m - \ell n]^2 - 4}{8\ell(\ell + 2)} + \frac{1}{32} [1 - (-1)^{m-n}], \quad (98)$$

where m, n are integers subject to $1 \leq m < \ell, 1 \leq n < \ell + 2$. Here $(m - n)$ is even for the NS sector while $(m - n)$ is odd for the R sector.

The $\mathcal{N} = 1$ supersymmetric minimal model $\mathcal{SM}(6, 4)$ has central charge $c = 1$ and the NS sector involves four primaries of weight $h^{NS} = 0, 1/16, 1/6, 1$. One can show that the q -series solutions to the MLDE with $c = 1$ in Table C1 can be expressed in terms of $\chi_{m,n}^{NS}$ as follows:

$$\begin{aligned} f_0(\tau) &= \chi_{1,1}^{NS}(\tau; \ell = 4) + \chi_{1,5}^{NS}(\tau; \ell = 4) = q^{-\frac{1}{24}} \left(1 + q + 2q^{\frac{3}{2}} + 2q^2 + 2q^{\frac{5}{2}} + \dots \right), \\ f_1(\tau) &= \chi_{1,3}^{NS}(\tau; \ell = 4) = q^{\frac{1}{6} - \frac{1}{24}} \left(1 + q^{\frac{1}{2}} + q + q^{\frac{3}{2}} + 2q^2 + 3q^{\frac{5}{2}} + \dots \right) \end{aligned} \quad (99)$$

Moreover, using the known S -matrix of $\mathcal{SM}(6, 4)$, one can verify that these two solutions transform into themselves under S transformation;

$$\begin{pmatrix} f_0(-\frac{1}{\tau}) \\ f_1(-\frac{1}{\tau}) \end{pmatrix} = \frac{1}{\sqrt{3}} \begin{pmatrix} 1 & 2 \\ 1 & -1 \end{pmatrix} \begin{pmatrix} f_0(\tau) \\ f_1(\tau) \end{pmatrix}. \quad (100)$$

The above modular S-transformation matrix is neither unitary nor symmetric, but leaves the matrix $\text{diag}(1, 2)$ invariant. Thus Γ_θ invariant NS partition function is given by

$$Z^{\text{NS}} = \left| f_0(\tau) \right|^2 + 2 \left| f_1(\tau) \right|^2. \tag{101}$$

The multiplicity $\mathcal{M} = 2$ in Eq. (101) suggests that there are two different primaries associated with the same character $f_1(\tau)$. In other words, the theory of our interest has three NS characters, denoted by \hat{f}_0, \hat{f}_1 and \hat{f}_2 , with $\hat{f}_0 = f_0^{(1)}$ and $\hat{f}_{1,2} = f_1^{(1)}$, that transform under the S transformation as follows:

$$\begin{pmatrix} \hat{f}_0(-\frac{1}{\tau}) \\ \hat{f}_1(-\frac{1}{\tau}) \\ \hat{f}_2(-\frac{1}{\tau}) \end{pmatrix} = S \begin{pmatrix} \hat{f}_0(\tau) \\ \hat{f}_1(\tau) \\ \hat{f}_2(\tau) \end{pmatrix}, \tag{102}$$

with

$$S = \begin{pmatrix} \frac{1}{\sqrt{3}} & \frac{1}{\sqrt{3}} & \frac{1}{\sqrt{3}} \\ \frac{1}{\sqrt{3}} & \frac{1}{\sqrt{3}} e^{\pm 2\pi i/3} & \frac{1}{\sqrt{3}} e^{\mp 2\pi i/3} \\ \frac{1}{\sqrt{3}} & \frac{1}{\sqrt{3}} e^{\mp 2\pi i/3} & \frac{1}{\sqrt{3}} e^{\pm 2\pi i/3} \end{pmatrix}. \tag{103}$$

Here the sign of exponents can be flipped as the role of \hat{f}_1 and \hat{f}_2 exchanges. Note that the modular S -matrix (103) is symmetric and satisfies $S^2 = 1$. Once we have the symmetric S -matrix, the fusion rule algebra coefficients are followed by the Verlinde formula

$$N_{ij}^k = \sum_{\ell} \frac{S_{i\ell} S_{j\ell} (S^{-1})_{\ell k}}{S_{0\ell}}, \tag{104}$$

where the index 0 denotes the vacuum. Using the Verlinde formula, we can obtain the well-defined fusion algebra given below.

$$\begin{aligned} N_{00}^0 &= N_{01}^1 = N_{10}^1 = N_{02}^2 = N_{20}^2 = 1, \\ N_{11}^2 &= N_{22}^1 = N_{12}^0 = N_{21}^0 = 1, \quad N_{ij}^k = 0 \quad \text{otherwise.} \end{aligned} \tag{105}$$

Let us comment on the $\widetilde{\text{NS}}$ sector and R sector partition function. The transformation rule of the $\widetilde{\text{NS}}$ sector and R sector characters are given by

$$\begin{pmatrix} f_0^{\widetilde{\text{NS}}}(-\frac{1}{\tau}) \\ f_1^{\widetilde{\text{NS}}}(-\frac{1}{\tau}) \end{pmatrix} = \frac{1}{\sqrt{3}} \begin{pmatrix} \sqrt{2} & 1 \\ \frac{1}{\sqrt{2}} & -1 \end{pmatrix} \begin{pmatrix} f_0^{\text{R}}(\tau) \\ f_1^{\text{R}}(\tau) \end{pmatrix}. \tag{106}$$

One can read the $\widetilde{\text{NS}}$ sector partition function by taking T -transformation to Eq. (101).

$$Z^{\widetilde{\text{NS}}} = \left| f_0^{\widetilde{\text{NS}}}(\tau) \right|^2 + 2 \left| f_1^{\widetilde{\text{NS}}}(\tau) \right|^2. \tag{107}$$

The Ramond sector partition function can be obtained from the S -matrix (106). Because the S -matrix leaves $\text{diag}(1, 1)$ invariant, the R sector partition function takes a form of

$$Z^{\text{R}} = \left| f_0^{\text{R}}(\tau) \right|^2 + \left| f_1^{\text{R}}(\tau) \right|^2. \tag{108}$$

In fact, the above fermionic model with $c = 1$ can be understood with the $\mathcal{N} = 2$ supersymmetric A_1 minimal model, also known as the Kazama–Suzuki model with level one. The $\mathcal{N} = 2$ supersymmetric A_k minimal model has the central charge

$$c(k) = \frac{3k}{k+2} \quad (k = 1, 2, 3, \dots), \tag{109}$$

and super-Virasoro characters of weight $h^{\text{NS}}(a, b)$ and $U(1)$ R-charge $Q^{\text{NS}}(a, b)$ in the NS sector read

$$h^{\text{NS}}(a, b) = \frac{1}{k+2} \left(ab - \frac{1}{4} \right), \quad Q^{\text{NS}}(a, b) = \frac{a-b}{k+2}, \tag{110}$$

with $a, b \in \mathbb{Z} + 1/2$ and $0 < a, b, (a+b) \leq k+1$. The explicit form of the $\mathcal{N} = 2$ super-Virasoro character in the NS sector is given by

$$\text{ch}_{h,Q}^{\text{NS}}(\tau, z) = q^{-\frac{c(k)}{24} + h(a,b)} y^{Q(a,b)} \cdot \varphi^{\text{NS}}(\tau, z) \cdot \Gamma_{a,b}^{(k)}(\tau, z), \tag{111}$$

with

$$\begin{aligned} \varphi^{\text{NS}} &= \prod_{n=1}^{\infty} \frac{(1 + yq^{n-\frac{1}{2}})(1 + y^{-1}q^{n-\frac{1}{2}})}{(1 - q^n)^2}, \\ \Gamma_{a,b}^{(k=\ell-2)} &= \prod_{n=1}^{\infty} \frac{(1 - q^{\ell(n-1)+a+b})(1 - q^{\ell n - a - b})(1 - q^{\ell n})^2}{(1 + yq^{\ell n - a})(1 + y^{-1}q^{\ell(n-1)+a})(1 + y^{-1}q^{\ell n - b})(1 + yq^{\ell(n-1)+b})}, \end{aligned} \tag{112}$$

Here $y = e^{2\pi iz}$ with the chemical potential z for the $U(1)_R$ charge. The Kazama–Suzuki model with $k = 1$ has $c = 1$, and three NS characters of $(h^{\text{NS}}, Q^{\text{NS}}) = (0, 0), (\frac{1}{6}, \pm\frac{1}{3})$. One can see that, after turning off the chemical potential, $f_0^{\text{NS}}(\tau)$ and $f_1^{\text{NS}}(\tau)$ become the $\mathcal{N} = 2$ NS characters

$$\chi_{0,0}^{\text{NS}}(\tau, z = 0) = f_0^{\text{NS}}(\tau), \quad \chi_{\frac{1}{6}, \frac{1}{3}}^{\text{NS}}(\tau, 0) = \chi_{\frac{1}{6}, -\frac{1}{3}}^{\text{NS}}(\tau, 0) = f_1^{\text{NS}}(\tau). \tag{113}$$

Fermionic RCFT with $c = 9/4$ The $c = 9/4$ fermionic RCFT with two NS characters can be understood as the fermionization of the \mathfrak{a}_1 WZW model with level six.

The \mathfrak{a}_1 WZW model with level six has central charge $c = 9/4$ and its torus partition function can be expressed in terms of seven characters $\chi_h^{\widehat{su}(2)_6}(\tau)$ of conformal weights $h = 0, 3/32, 1/4, 15/32, 3/4, 35/32, 3/2$. In terms of characters of the WZW model, $f_0^{\text{NS}}(\tau)$ and $f_1^{\text{NS}}(\tau)$ with $c = 9/4$ can be written as

$$\begin{aligned} f_0^{\text{NS}} &= \chi_0^{\widehat{su}(2)_6} + \chi_{\frac{3}{2}}^{\widehat{su}(2)_6} = q^{-\frac{3}{32}} \left(1 + 3q + 7q^{\frac{3}{2}} + 9q^2 + 12q^{\frac{5}{2}} + \dots \right), \\ f_1^{\text{NS}} &= \chi_{\frac{1}{4}}^{\widehat{su}(2)_6} + \chi_{\frac{3}{4}}^{\widehat{su}(2)_6} = q^{\frac{1}{4} - \frac{3}{32}} \left(3 + 5q^{\frac{1}{2}} + 9q + 15q^{\frac{3}{2}} + 27q^2 + 45q^{\frac{5}{2}} + \dots \right). \end{aligned} \tag{114}$$

The modular S -matrix now becomes

$$S = \begin{pmatrix} \sin \frac{\pi}{8} & \cos \frac{\pi}{8} \\ \cos \frac{\pi}{8} & -\sin \frac{\pi}{8} \end{pmatrix}, \tag{115}$$

which is already symmetric, meaning that there are only two primaries in the NS sector and no need to find an extended S -matrix. Then the fusion coefficients can be read off from the Verlinde formula,

$$N_{00}^0 = N_{10}^1 = N_{01}^1 = N_{11}^0 = 1, \quad N_{11}^1 = 2, \quad N_{ij}^k = 0 \text{ otherwise}. \tag{116}$$

From Eq. (115), the Γ_θ invariant NS partition function is given by

$$Z_{\text{NS}} = \left| f_0^{\text{NS}}(\tau) \right|^2 + \left| f_1^{\text{NS}}(\tau) \right|^2 = \left| \chi_0^{\widehat{su}(2)_6} + \chi_{\frac{3}{2}}^{\widehat{su}(2)_6} \right|^2 + \left| \chi_{\frac{1}{4}}^{\widehat{su}(2)_6} + \chi_{\frac{3}{4}}^{\widehat{su}(2)_6} \right|^2. \tag{117}$$

Applying suitable modular transformations on $f_{0,1}^{\text{NS}}(\tau)$ gives other partition functions for different spin structures,

$$\begin{aligned} Z_{\widetilde{\text{NS}}} &= \left| \chi_0^{\widehat{su}(2)_6} - \chi_{\frac{3}{2}}^{\widehat{su}(2)_6} \right|^2 + \left| \chi_{\frac{1}{4}}^{\widehat{su}(2)_6} - \chi_{\frac{3}{4}}^{\widehat{su}(2)_6} \right|^2, \\ Z_{\text{R}} &= \left| \chi_{\frac{3}{32}}^{\widehat{su}(2)_6} + \chi_{\frac{35}{32}}^{\widehat{su}(2)_6} \right|^2 + \left| \sqrt{2} \chi_{\frac{15}{32}}^{\widehat{su}(2)_6} \right|^2. \end{aligned} \tag{118}$$

Finally, the $\text{SL}_2(\mathbb{Z})$ invariant $\widetilde{\text{R}}$ partition function is

$$Z_{\widetilde{\text{R}}} = \left| \chi_{\frac{3}{32}}^{\widehat{su}(2)_6} - \chi_{\frac{35}{32}}^{\widehat{su}(2)_6} \right|^2 = 4, \tag{119}$$

which suggests that the theory of our interest could be supersymmetric. The GSO projection (or equivalently the bosonization) leads to the torus partition function of the $su(2)$ WZW model with level six,

$$\begin{aligned} Z(\tau, \bar{\tau}) &= \frac{1}{2} \left[Z_{\text{NS}}(\tau, \bar{\tau}) + Z_{\widetilde{\text{NS}}}(\tau, \bar{\tau}) + Z_{\text{R}}(\tau, \bar{\tau}) + Z_{\widetilde{\text{R}}}(\tau, \bar{\tau}) \right], \\ &= \left| \chi_0^{\widehat{su}(2)_6} \right|^2 + \left| \chi_{\frac{3}{32}}^{\widehat{su}(2)_6} \right|^2 + \left| \chi_{\frac{1}{4}}^{\widehat{su}(2)_6} \right|^2 + \left| \chi_{\frac{15}{32}}^{\widehat{su}(2)_6} \right|^2 + \left| \chi_{\frac{3}{4}}^{\widehat{su}(2)_6} \right|^2 + \left| \chi_{\frac{35}{32}}^{\widehat{su}(2)_6} \right|^2 + \left| \chi_{\frac{3}{2}}^{\widehat{su}(2)_6} \right|^2, \end{aligned} \tag{120}$$

as expected. It was shown recently in Ref. [32] that this model indeed has $\mathcal{N} = 1$ supersymmetric vertex operator algebra.

We find that two solutions (114) can be expressed in terms of the characters of the $\mathcal{N} = 1$ supersymmetric minimal models $\mathcal{SM}(6, 4)$ and $\mathcal{SM}(8, 6)$ as follows:

$$\begin{aligned} f_0(\tau) &= (\chi_{1,1}^{\ell=4} + \chi_{1,5}^{\ell=4})(\chi_{1,1}^{\ell=6} + \chi_{1,7}^{\ell=6}) + 2\chi_{1,3}^{\ell=4} \chi_{3,1}^{\ell=6}, \\ f_1(\tau) &= (\chi_{1,1}^{\ell=4} + \chi_{1,5}^{\ell=4})(\chi_{1,3}^{\ell=6} + \chi_{1,5}^{\ell=6}) + 2\chi_{1,3}^{\ell=4} \chi_{3,3}^{\ell=6}. \end{aligned} \tag{121}$$

We also note that $c = 9/4$ is one of the central charges for the minimal $\mathcal{N} = 2$ model (109). Indeed, we can show that two NS characters with the $\text{SU}(2)$ chemical potential turned on can be expressed in terms of the $\mathcal{N} = 2$ NS characters with $U(1)_R$ chemical potential turned on:

$$\begin{aligned} \left[\chi_0^{\widehat{su}(2)_6} + \chi_{\frac{3}{2}}^{\widehat{su}(2)_6} \right] \left(\tau, \frac{z}{2} \right) &= \left[\text{ch}_{0,0}^{(\frac{4}{9})\text{NS}} + \text{ch}_{1,\frac{1}{2}}^{(\frac{4}{9})\text{NS}} + \text{ch}_{1,-\frac{1}{2}}^{(\frac{4}{9})\text{NS}} + \text{ch}_{\frac{3}{2},0}^{(\frac{4}{9})\text{NS}} \right] (\tau, z), \\ \left[\chi_{\frac{1}{4}}^{\widehat{su}(2)_6} + \chi_{\frac{3}{4}}^{\widehat{su}(2)_6} \right] \left(\tau, \frac{z}{2} \right) &= \left[\text{ch}_{\frac{1}{4},0}^{(\frac{4}{9})\text{NS}} + \text{ch}_{\frac{1}{4},\frac{1}{2}}^{(\frac{4}{9})\text{NS}} + \text{ch}_{\frac{1}{4},-\frac{1}{2}}^{(\frac{4}{9})\text{NS}} + \text{ch}_{\frac{3}{4},0}^{(\frac{4}{9})\text{NS}} \right] (\tau, z). \end{aligned} \tag{122}$$

Fermionic RCFT with $c = 6$ One can identify the solutions to the second-order MLDE with $c = 6$ as the fermionization of the six-fold product of the \mathfrak{a}_1 WZW model with level one. This model has been recently studied in Ref. [44] with the aim of understanding the origin of the Mathieu moonshine of the K3 CFT. In particular, the quantum hexacode was utilized to construct the $N = 1$ supersymmetry current out of 2^6 primaries of weight $3/2$. The level one \mathfrak{a}_1 WZW model, denoted by $\widehat{su}(2)_1$ for later convenience, has central charge $c = 1$ and contains two characters, one of which

corresponds to the vacuum and the other to the primary of conformal weight $h = 1/4$. The explicit form of the two characters is

$$\begin{aligned} \psi_0(\tau) &= \sqrt{\frac{\vartheta_3^2(\tau) + \vartheta_4^2(\tau)}{2\eta^2(\tau)}} = q^{-\frac{1}{24}} (1 + 3q + 4q^2 + 7q^3 + \dots), \\ \psi_{\frac{1}{4}}(\tau) &= \sqrt{\frac{\vartheta_3^2(\tau) - \vartheta_4^2(\tau)}{2\eta^2(\tau)}} = 2q^{\frac{5}{24}} (1 + q + 3q^2 + 4q^3 + \dots). \end{aligned} \tag{123}$$

Under $S : \tau \rightarrow -1/\tau$, ψ_0 and ψ_1 transform as

$$\begin{pmatrix} \psi_0(-\frac{1}{\tau}) \\ \psi_1(-\frac{1}{\tau}) \end{pmatrix} = \begin{pmatrix} \frac{1}{\sqrt{2}} & \frac{1}{\sqrt{2}} \\ \frac{1}{\sqrt{2}} & -\frac{1}{\sqrt{2}} \end{pmatrix} \begin{pmatrix} \psi_0(\tau) \\ \psi_1(\tau) \end{pmatrix}. \tag{124}$$

The six-fold product of $\widehat{su}(2)_1$ has 2^6 primaries, many of which become degenerate. There are eventually seven different characters of conformal weights $h = 0, 1/4, 1/2, 3/4, 1, 5/4, 3/2$, given by

$$\chi_{\frac{n}{4}}(\tau) = \psi_0^{6-n}(\tau) \cdot \psi_{\frac{1}{4}}^n(\tau), \quad (n = 0, 1, \dots, 6). \tag{125}$$

We can express two solutions with $c = 6$ in Table 5 in terms of $\chi_{\frac{n}{4}}(\tau)$,

$$\begin{aligned} f_0^{\text{NS}}(\tau) &= \chi_0(\tau) + \chi_{\frac{3}{2}}(\tau) = q^{-\frac{1}{4}} (1 + 18q + 64q^{\frac{3}{2}} + 159q^2 + 384q^{\frac{5}{2}} + \dots), \\ f_1^{\text{NS}}(\tau) &= \chi_{\frac{1}{2}}(\tau) + \chi_1(\tau) = 4q^{\frac{1}{4}} (1 + 4q^{\frac{1}{2}} + 14q + 40q^{\frac{3}{2}} + 101q^2 + \dots). \end{aligned} \tag{126}$$

The modular S -matrix can be read off from Eq. (124) as

$$\begin{pmatrix} f_0^{\text{NS}}(-\frac{1}{\tau}) \\ f_1^{\text{NS}}(-\frac{1}{\tau}) \end{pmatrix} = \frac{1}{4} \begin{pmatrix} 1 & 15 \\ 1 & -1 \end{pmatrix} \begin{pmatrix} f_0^{\text{NS}}(\tau) \\ f_1^{\text{NS}}(\tau) \end{pmatrix}, \tag{127}$$

which implies that the NS partition function has to be

$$Z_{\text{NS}} = |f_0^{\text{NS}}(\tau)|^2 + 15|f_1^{\text{NS}}(\tau)|^2. \tag{128}$$

The multiplicity 15 in Eq. (128), which says there are 15 primaries associated with $f_1^{\text{NS}}(\tau)$, is reflected in the non-symmetric and non-unitary modular matrix in Eq. (127). This implies that we have to find a 16×16 extended S -matrix \widehat{S} . To this end, let us first denote the extended characters as

$$\begin{aligned} \widehat{f}_0^{\text{NS}}(\tau) &= f_0^{\text{NS}}(\tau), \\ \widehat{f}_{1,\alpha}^{(3)}(\tau) &= \psi_0 \otimes \dots \otimes \psi_1 \dots \otimes \psi_1 \dots \otimes \psi_0 + (0 \leftrightarrow 1), \end{aligned} \tag{129}$$

where the index α means $\alpha = \{i, j\}$ for $1 \leq i < j \leq 6$. For the 16 component vector-valued modular form $(\widehat{f}_0^{(3)}, \widehat{f}_{1,\alpha}^{(3)}(\tau))$, the below 16×16 matrix whose components are

$$\begin{aligned} S_{00} &= S_{\alpha\alpha} = +\frac{1}{4}, \quad S_{0\alpha} = S_{\alpha 0} = +\frac{1}{4}, \\ S_{\alpha\beta} &= \begin{cases} +\frac{1}{4} & \text{if } \alpha \cap \beta = \emptyset, \\ -\frac{1}{4} & \text{otherwise,} \end{cases} \end{aligned} \tag{130}$$

acts as the extended \hat{S} -matrix. Now the fusion rules follow from the Verlinde formula;

$$N_{00}^0 = N_{0\alpha}^\alpha = N_{\alpha 0}^\alpha = N_{\alpha\alpha}^0 = 1,$$

$$N_{\alpha\beta}^\gamma = \begin{cases} 1 & \text{if } \alpha \cup \beta \cup \gamma = \{1, \dots, 6\} \text{ or } \alpha \cup \beta = \gamma \cup (\alpha \cap \beta), \\ 0 & \text{otherwise.} \end{cases} \tag{131}$$

Performing T and S transformation on the NS characters, one can obtain the $\widetilde{\text{NS}}$ and R partition functions

$$Z_{\widetilde{\text{NS}}} = |f_0^{\widetilde{\text{NS}}}(\tau)|^2 + 15|f_1^{\widetilde{\text{NS}}}(\tau)|^2 = \left| \chi_0 - \chi_{\frac{3}{2}} \right|^2 + 15 \left| \chi_{\frac{1}{2}} - \chi_1 \right|^2,$$

$$Z_{\text{R}} = 6|f_0^{\text{R}}(\tau)|^2 + 40|f_1^{\text{R}}(\tau)|^2 = 6 \left| \chi_{\frac{1}{4}} + \chi_{\frac{5}{4}} \right|^2 + 20 \left| \sqrt{2}\chi_{\frac{3}{4}} \right|^2. \tag{132}$$

Analogous to the previous example of $c = 9/4$, the $\widetilde{\text{R}}$ partition function becomes constant,

$$Z_{\widetilde{\text{R}}} = 6 \left| \chi_{\frac{1}{4}} - \chi_{\frac{5}{4}} \right|^2 = 24, \tag{133}$$

which is consistent with the fact that there is a unique $N = 1$ supersymmetry current in the $(\widehat{su}(2)_1)^6$ [44]. One can also see that the GSO projection of the theory with $c = 6$ leads to the $(\widehat{su}(2)_1)^6$.

Dual fermionic RCFTs with $c = 11$ and $c = 39/4$ Let us make comments on the duality relation among the solutions. We take the three pairs for the BPS type I solutions

$$(c, \tilde{c} = 12 - c) = (1, 11), \quad \left(\frac{9}{4}, \frac{39}{4} \right), \quad (6, 6), \tag{134}$$

where the $c = 6$ solution is self-dual. Note that the NS weights h^{NS} and \tilde{h}^{NS} of the dual pairs satisfy $h^{\text{NS}} + \tilde{h}^{\text{NS}} = 1$. We find that the NS sector solutions of BPS type I $(f_0^{(c)}(\tau), f_1^{(c)}(\tau))$ and their dual pairs $(\tilde{f}_0^{(12-c)}(\tau), \tilde{f}_1^{(12-c)}(\tau))$ are combined to produce the bilinear relation

$$f_0^{(c)} \tilde{f}_0^{(12-c)} + \mathcal{M}^{(c)} f_1^{(c)} \tilde{f}_1^{(12-c)} = K(\tau), \tag{135}$$

where $\mathcal{M}^{(c=1)} = 2$, $\mathcal{M}^{(c=9/4)} = 2$ and $\mathcal{M}^{(c=6)} = 15$. The coefficient $\mathcal{M}^{(c)}$ agrees with the degeneracy of the primaries in each case, and it is thus guaranteed that the bilinear relation holds even after introducing the extended S -matrix. Since $K(\tau)$ is invariant under the S transformation, the dual pairs $(\tilde{f}_0^{(12-c)}(\tau), \tilde{f}_1^{(12-c)}(\tau))$ share the same S -matrix of $(f_0^{(c)}(\tau), f_1^{(c)}(\tau))$. Therefore, the bilinear relation suggests that the two theories in a given pair have identical fusion rule algebra. Explicitly, the fusion rules of the $c = 11$ putative theory are given by Eq. (5.3.1) while the hypothetical theory of $c = 39/4$ has fusion rules (116).

The $\mathcal{N} = 1$ superconformal field theory with $c = 12$ has been constructed in Ref. [45] and its partition function can be factorized into $K(\tau)K(\bar{\tau})$. Analogous to the deconstruction of the Monster CFT by two bosonic RCFTs discussed in Refs. [16,17], Eq. (135) suggests that one can deconstruct the $c = 12$ superconformal field theory by two fermionic RCFTs. On the one hand, the $c = 12$ superconformal theory is known to have symmetry group $\text{Co}_0 = 2.\text{Co}_1$ [46]. Therefore, it is natural to expect that the dual pairs exhibit moonshine phenomena for some subgroup of Co_0 . For instance, let us consider the putative $c = 11$ theory. Our solution for $c = 11$ can be identified to the characters of $\mathcal{N} = 1$ Supersymmetric VOA (SVOA) with $c = 11$ given in Ref. [32]. The automorphism

Table 6. The list of eight BPS solutions with $a_1 \neq 0$.

c	$\frac{3}{4}$	$\frac{3}{2}$	3	6	9	$\frac{21}{2}$	$\frac{45}{4}$	12
h^{ns}	$\frac{1}{4}$	$\frac{1}{4}$	$\frac{1}{3}$	$\frac{1}{2}$	$\frac{2}{3}$	$\frac{3}{4}$	$\frac{3}{4}$	$[\frac{5}{6}]$
h_{\pm}^r	$\frac{1}{32}, \frac{5}{32}$	$\frac{1}{16}, \frac{5}{16}$	$\frac{1}{8}, \frac{11}{24}$	$\frac{1}{4}, \frac{3}{4}$	$\frac{3}{8}, \frac{25}{24}$	$\frac{7}{16}, \frac{19}{16}$	$\frac{15}{32}, \frac{43}{32}$	$\frac{1}{2}, [\frac{4}{3}]$
a_1	1	1	2	4	6	7	15	8
\mathcal{M}	1	1	2	3	2	1	1	[0]

group of $\mathcal{N} = 1$ SVOA with $c = 11$ is known as the Suzuki group, which is one of the maximal subgroups of Co_0 . It would be interesting to investigate further deconstruction examples of $c = 12$ superconformal theory, and the details will be discussed in an upcoming paper [33].

5.3.2. *BPS type II: BPS solutions with free fermion currents*

Let us then consider a mild generalization to explore the space of BPS solutions that contain free fermions. To do so, we consider the case that each NS sector vacuum character accommodates for the $q^{1/2-c/24}$ term, namely,

$$f_0^{NS}(q) = q^{-\frac{c}{24}} \left(1 + a_1 q^{\frac{1}{2}} + \mathcal{O}(q) \right). \tag{136}$$

As shown in Eq. (82), the weights of the primaries in each sector are given by

$$h_-^r = \frac{c}{24}, \quad h_+^r = \frac{5c}{24} - 2h^{ns} + \frac{1}{2}, \quad h^{ns} = \frac{4c^2 + 6c + 9a_1}{6(10c + 3a_1)}, \tag{137}$$

when the unitarity bound is saturated. As a consequence, the solutions of the second-order MLDE are in general expressed as the rational functions of c and a_1 . We search for the values of c and a_1 leading to non-negative integer Fourier coefficients of each solution. In what follows, we discuss BPS solutions by imposing $c > 0$ and $a_1 \neq 0$, which are summarized in Table 6. The explicit solutions in q -series can be found in Tables C3 and C4.

Supersymmetric Lee–Yang model For the solutions with $(c, h^{ns}) = (3/4, 1/4)$, one of the fusion rules turns out to be a negative number. This means that the solutions cannot be regarded as conformal characters, as they stand. To reconcile this, we exchange the role of vacuum and non-vacuum characters. After the interchange of characters, the theory can be identified to the supersymmetric version of the Lee–Yang edge model, namely the $\mathcal{N} = 1$ supersymmetric non-unitary minimal model $\mathcal{SM}(8, 2)$, with negative central charge $c = -21/4$.

The supersymmetric Lee-Yang edge model has two NS characters of weight $h = 0$ and $h = -1/4$,

$$\begin{aligned} \chi_0^{ns}(q) &= q^{\frac{7}{32}} \prod_{n=0}^{\infty} \frac{1}{\left(1 - q^{\frac{1}{2}(8n+3)}\right) \left(1 - q^{\frac{1}{2}(8n+4)}\right) \left(1 - q^{\frac{1}{2}(8n+5)}\right)}, \\ \chi_{-\frac{1}{4}}^{ns}(q) &= q^{-\frac{1}{32}} \prod_{n=0}^{\infty} \frac{1}{\left(1 - q^{\frac{1}{2}(8n+1)}\right) \left(1 - q^{\frac{1}{2}(8n+4)}\right) \left(1 - q^{\frac{1}{2}(8n+7)}\right)}, \end{aligned} \tag{138}$$

and two R characters of weight $h = -3/32$ and $h = -7/32$,

$$\chi_{-\frac{3}{32}}^r(q) = q^{\frac{1}{8}} \prod_{n=1}^{\infty} (q^n + 1) (q^{2n} + 1), \quad \chi_{-\frac{7}{32}}^r(q) = \prod_{n=1}^{\infty} (q^{2n-1} + 1) (q^n + 1). \tag{139}$$

The solution of $c = 3/4$ in Table 6 can then be identified as

$$f_0^{\text{NS}}(\tau) = \chi_{-\frac{1}{4}}^{\text{ns}}(q), \quad f_1^{\text{NS}}(\tau) = \chi_0^{\text{ns}}(q), \quad f_0^{\text{R}}(\tau) = \chi_{-\frac{7}{32}}^{\text{r}}(q), \quad f_1^{\text{R}}(\tau) = \chi_{-\frac{3}{32}}^{\text{r}}(q). \quad (140)$$

From the modular S -matrix below,

$$\begin{pmatrix} f_1^{\text{NS}}(-\frac{1}{\tau}) \\ f_0^{\text{NS}}(-\frac{1}{\tau}) \end{pmatrix} = \begin{pmatrix} -\cos \frac{\pi}{8} & \sin \frac{\pi}{8} \\ \sin \frac{\pi}{8} & \cos \frac{\pi}{8} \end{pmatrix} \begin{pmatrix} f_1^{\text{NS}}(\tau) \\ f_2^{\text{NS}}(\tau) \end{pmatrix}, \quad (141)$$

we can read off the fusion rules

$$N_{00}^0 = N_{10}^1 = N_{01}^1 = N_{11}^0 = 1, \quad N_{11}^1 = 2, \quad N_{ij}^k = 0 \text{ otherwise.} \quad (142)$$

Note that all fusion coefficients become non-negative integers.

Supersymmetric ADE WZW models with level one We claim that the solutions with $c = 3/2, 3, 6, 9, 21/2$ can be understood as the $\mathcal{N} = 1$ supersymmetric ADE WZW model with level one.

Let us start with the tensor product of free Majorana fermions and the WZW model with level one. The number of Majorana fermions is given by the rank of a group on which the WZW model is defined. The theory then has two NS characters which take the forms

$$\begin{aligned} f_0^{\text{NS}}(\tau) &= \left(\psi^{\text{NS}}(\tau)\right)^{\text{rk}(\mathfrak{g})} \cdot \chi_0^{\mathfrak{g}}(\tau), \\ f_1^{\text{NS}}(\tau) &= \left(\psi^{\text{NS}}(\tau)\right)^{\text{rk}(\mathfrak{g})} \cdot \chi_1^{\mathfrak{g}}(\tau), \end{aligned} \quad (143)$$

where $\psi^{\text{NS}}(\tau) = \sqrt{\vartheta_3(\tau)/\eta(\tau)}$ is the NS character for a single Majorana fermion as given in Eq. (67). The terms $\chi_0^{\mathfrak{g}}(\tau)$ and $\chi_1^{\mathfrak{g}}(\tau)$ denote the vacuum and non-degenerate characters of the level-one WZW model on \mathfrak{g} . When $\mathfrak{g} = \mathfrak{a}_1, \mathfrak{a}_2, \mathfrak{d}_4, \mathfrak{e}_6, \mathfrak{e}_7$, the above characters (143) reproduce the BPS solutions for $c = 3/2, 3, 6, 9, 21/2$, respectively.

We notice that the level-one WZW model on a simply-laced Lie algebra \mathfrak{g} can be realized as rank of \mathfrak{g} , $\text{rk} \mathfrak{g}$ free bosons on the root-lattice of \mathfrak{g} , which is referred to as the Frenkel–Kac construction [47,48]. Thus, we can describe the fermionic RCFTs with $c = 3/2, 3, 6, 9, 21/2$ as the $\mathcal{N} = 1$ supersymmetric theories of $\text{rk}(\mathfrak{g})$ pairs of free boson and fermion.

By construction, the modular matrices of the above BPS solutions are governed by those of the corresponding WZW model:

- (1) For instance, the modular S -matrix of the $c = 3/2$ BPS solution becomes

$$S = \frac{1}{\sqrt{2}} \begin{pmatrix} 1 & 1 \\ 1 & -1 \end{pmatrix}. \quad (144)$$

It is straightforward to read the fusion rule algebra coefficients using the Verlinde formula. The non-vanishing coefficients are given by

$$N_{00}^0 = N_{10}^1 = N_{01}^1 = N_{11}^0 = 1, \quad (145)$$

thus we have a consistent fusion rule as expected. The Γ_θ invariant NS partition function is

$$Z_{\text{NS}} = \left|f_0^{\text{NS}}(\tau)\right|^2 + \left|f_1^{\text{NS}}(\tau)\right|^2. \quad (146)$$

- (2) The $c = 3$ fermionic RCFTs have two primaries associated with the same characters $f_1^{\text{NS}}(\tau)$. They rotate as $\mathbf{3}$ and $\bar{\mathbf{3}}$ under $SU(3)$. In the basis of $(\hat{f}_0^{\text{NS}}, \hat{f}_1^{\text{NS}}, \hat{f}_2^{\text{NS}}) = (f_0^{\text{NS}}, f_1^{\text{NS}}, f_1^{\text{NS}})$, the modular S -matrix is given by

$$\hat{S} = \begin{pmatrix} \frac{1}{\sqrt{3}} & \frac{1}{\sqrt{3}} & \frac{1}{\sqrt{3}} \\ \frac{1}{\sqrt{3}} & \frac{1}{\sqrt{3}} e^{2\pi i/3} & \frac{1}{\sqrt{3}} e^{-2\pi i/3} \\ \frac{1}{\sqrt{3}} & \frac{1}{\sqrt{3}} e^{-2\pi i/3} & \frac{1}{\sqrt{3}} e^{2\pi i/3} \end{pmatrix}. \tag{147}$$

This gives the consistent fusion rules

$$\begin{aligned} N_{00}^0 &= N_{01}^1 = N_{10}^1 = N_{02}^2 = N_{20}^2 = 1, \\ N_{11}^2 &= N_{22}^1 = N_{12}^0 = N_{21}^0 = 1, \quad N_{ij}^k = 0 \text{ otherwise.} \end{aligned} \tag{148}$$

The NS partition function is thus given by

$$Z_{\text{NS}} = \left| f_0^{\text{NS}}(\tau) \right|^2 + 2 \left| f_1^{\text{NS}}(\tau) \right|^2. \tag{149}$$

- (3) For the $\mathcal{N} = 1$ supersymmetric level-one WZW model on \mathfrak{d}_4 , we have three primaries that are associated with the same character $f_1^{\text{NS}}(\tau)$ but transform differently under $SO(8)$ as the vector $\mathbf{8}_v$, the chiral spinor $\mathbf{8}_s$, and the anti-chiral spinor $\mathbf{8}_c$. In the basis of $(\hat{f}_0^{\text{NS}}, \hat{f}_1^{\text{NS}}, \hat{f}_2^{\text{NS}}, \hat{f}_3^{\text{NS}}) = (f_0^{\text{NS}}, f_1^{\text{NS}}, f_1^{\text{NS}}, f_1^{\text{NS}})$, the modular S -matrix becomes

$$\hat{S} = \begin{pmatrix} \frac{1}{2} & \frac{1}{2} & \frac{1}{2} & \frac{1}{2} \\ \frac{1}{2} & \frac{1}{2} & -\frac{1}{2} & -\frac{1}{2} \\ \frac{1}{2} & -\frac{1}{2} & \frac{1}{2} & -\frac{1}{2} \\ \frac{1}{2} & -\frac{1}{2} & -\frac{1}{2} & \frac{1}{2} \end{pmatrix}, \tag{150}$$

which leads to the fusion rules

$$N_{00}^0 = N_{01}^1 = N_{02}^2 = N_{03}^3 = N_{12}^3 = N_{23}^1 = N_{31}^2 = 1, \tag{151}$$

with all other $N_{ij}^k = 0$. The Γ_θ invariant NS partition function takes the form

$$Z_{\text{NS}} = \left| f_0^{\text{NS}}(\tau) \right|^2 + 3 \left| f_1^{\text{NS}}(\tau) \right|^2. \tag{152}$$

- (4) One can easily show that the modular S -matrices of the $c = 9$ and $c = 21/2$ solutions are shared by the $c = 3$ and $c = 3/2$ solutions, respectively. In fact, the $\mathcal{N} = 1$ supersymmetric level-one WZW model on \mathfrak{e}_6 (\mathfrak{e}_7) is dual to the supersymmetric \mathfrak{a}_2 (\mathfrak{a}_1) WZW model with level one, in the sense that their characters obey the bilinear relation (159) below.

Amusing examples are given by a one-parameter family of $c = 12$ solutions, each of which has the vacuum character

$$f_0^{\text{NS}}(\tau) = K(\tau) + n \quad (n \in \mathbb{Z}). \tag{153}$$

They do not provide consistent two-character theories, because the other character $f_1^{\text{NS}}(\tau)$ does not admit positive integer coefficients for any n . Nonetheless, the character $f_0^{\text{NS}}(\tau)$ is Γ_θ -invariant and serves as the NS partition function of a certain putative fermionic RCFT.

We argue that the integer parameter n can be further restricted to $n = 0, 2, 4, 8,$ and 24 in order to make the corresponding theories physically well-behaved. To see this, note that the parameter n of Eq. (153) is the number of free fermions contained in a given model. Equation (153) can thus split into two pieces as

$$K(\tau) + n = \left(\psi^{\text{NS}}(\tau)\right)^n \cdot \tilde{f}^{\text{NS}}(\tau), \tag{154}$$

where $\tilde{f}^{\text{NS}}(\tau)$ should be understood as the NS partition function of a $c = (12 - n/2)$ CFT with no free fermion. We found that $\tilde{f}^{\text{NS}}(\tau)$ fails to have positive integer coefficients in the q -expansion for $n > 8$ except $n = 24$. Another simple diagnostic to rule out an unphysical NS partition function is to analyse the degeneracy and weights in its R sector partition function [49]. One can show that, for $n = 1, 3, 5, 6,$ and 7 , the Ramond partition function has non-integer degeneracy and thus any fermionic RCFTs without free fermions cannot have $\tilde{f}^{\text{NS}}(\tau)$ as its NS partition function.

As discussed in the previous section, we can identify $f_0^{\text{NS}}(\tau)$ with $n = 24$ as the NS partition function of the 24 free Majorana–Weyl fermions (71). We also note that a system of 24 free Majorana fermions can be related to the $O(24)$ WZW model with level one via the non-abelian bosonization [50]. More explicitly, one can express $f_0^{\text{NS}}(\tau) = K(\tau) + 24$ in terms of the WZW characters as

$$f_0^{\text{NS}}(\tau) = \chi_0^{O(24)}(\tau) + \chi_{\frac{1}{2}}^{O(24)}(\tau), \tag{155}$$

where $\chi_0^{O(24)}(\tau)$ and $\chi_{1/2}^{O(24)}(\tau)$ are the WZW characters of the vacuum and conformal weight $h = 1/2$. The left-over character $\chi_{3/2}^{O(24)}(\tau)$ of the WZW model appears as the Ramond partition function,

$$f_0^{\text{R}}(\tau) = \sqrt{2}\chi_{\frac{3}{2}}^{O(24)}(\tau). \tag{156}$$

One can easily show that the GSO projection of the 24 free Majorana fermions gives the partition function of the level-one WZW model for $O(24)$.

It is worth mentioning that Eq. (153) for $n = 0$ is nothing but the NS partition function of the $c = 12$ extremal SCFT, also known as the Conway extremal CFT [31,46]. There are two different but equivalent constructions of it. One of them is based on the $\mathcal{N} = 1$ supersymmetric ϵ_8 WZW model with level one, followed by a \mathbb{Z}_2 orbifold [31]. The other is a \mathbb{Z}_2 orbifold of 24 free chiral fermions [46]. In both constructions, \mathbb{Z}_2 action is the charge conjugation. The second construction implies that the Conway extremal SCFT is the fermionization of the $SO(24)$ WZW model with level one [32]. To be concrete, the NS and R partition function of the extremal SCFT with $c = 12$ can be expressed in terms of the WZW characters

$$\begin{aligned} f_0^{\text{NS}}(\tau) &= \chi_0^{SO(24)}(\tau) + \chi_{\frac{3}{2}}^{SO(24)}(\tau), \\ f_0^{\text{R}}(\tau) &= \chi_{\frac{1}{2}}^{SO(24)}(\tau) + \chi_{\frac{3}{2}}^{SO(24)}(\tau). \end{aligned} \tag{157}$$

Table 7. The list of $c < 0$ BPS solutions with free fermion currents. Eventually every five solutions in this list are mapped to the unitary solution upon exchanging the vacuum solution and non-vacuum solution.

c	h^{ns}	h_-^r	h_+^r	a_1	Identification
-3	$-\frac{1}{6}$	$-\frac{1}{8}$	$\frac{5}{24}$	1	$c = 1$ solution of BPS type I
$-\frac{9}{2}$	$-\frac{1}{4}$	$-\frac{3}{16}$	$-\frac{1}{16}$	1	$c = \frac{3}{2}$ solution of BPS type II
-5	$-\frac{1}{3}$	$-\frac{5}{24}$	$\frac{1}{8}$	2	$c = 3$ solution of BPS type II
$-\frac{21}{4}$	$-\frac{1}{4}$	$-\frac{7}{32}$	$-\frac{3}{32}$	0	$c = \frac{3}{4}$ solution of BPS type II
-7	$-\frac{2}{3}$	$-\frac{7}{24}$	$\frac{3}{8}$	6	$c = 9$ solution of BPS type II

From the fact that $f_0^{\tilde{R}}(\tau) = \chi_{1/2}^{SO(24)}(\tau) - \chi_{3/2}^{SO(24)}(\tau) = 24$, the bosonization of the Conway extremal CFT indeed gives the torus partition function of the level-one WZW model on $SO(24)$. In fact $O(24)$ and $SO(24)$ WZW models share the same characters, and it is noteworthy that the $SL_2(\mathbb{Z})$ invariant partition function of the $SO(24)_1$ ($O(24)_1$) WZW model allows the two different fermionizations.

For $n = 8$, one can see that the $\mathcal{N} = 1$ supersymmetric level-one WZW model for ϵ_8 takes Eq. (153) as the NS partiton function, namely

$$\tilde{f}^{NS}(\tau) = \left(j(\tau)\right)^{\frac{1}{3}}. \tag{158}$$

However, it is not clear yet if there would exist fermionic RCFTs having $\tilde{f}^{NS}(\tau)$ with $n = 2, 4$ as the NS partition function, although they arise as solutions to second-order MLDEs which do not saturate the supersymmetric unitarity bound $h^R \geq c/24$. See Eq. (203) for details.

One can also observe that the supersymmetric ϵ_8 WZW model with level one exhibits various deconstructions into a pair of two supersymmetric WZW models: if $f_i^{NS}(\tau)$ and $\tilde{f}_i^{NS}(\tau)$ ($i = 0, 1$) are the NS characters of the central charge c and $(12 - c)$, then

$$K(\tau) + 8 = f_0^{NS} \tilde{f}_0^{NS}(\tau) + \mathcal{M}^{(c)} f_1^{NS} \tilde{f}_1^{NS}(\tau), \tag{159}$$

where $\mathcal{M}^{(c=3/2)} = 1$, $\mathcal{M}^{(c=3)} = 2$, and $\mathcal{M}^{(c=6)} = 3$. Indeed, Eq. (159) is a supersymmetric generalization of the bilinear relation (30), and thus potentially gives new insight into the supersymmetric modular tensor category.

We finally remark on the BPS solutions for $c < 0$. A complete list of BPS solutions with $c < 0$ and $a_1 \neq 0$ is presented in Table 7. Here both NS sector and R sector solutions have non-negative integer coefficients in q -series. One can show that every solution in Table 7 actually describes a unitary theory upon exchanging the vacuum and non-vacuum character. The precise mapping between BPS $c < 0$ solutions and BPS unitary solutions is given in Table 7.

5.4. Non-BPS solutions

A typical type of fermionic RCFT can be generated by tensoring the WZW models for a Lie algebra \mathfrak{g} with an arbitrary number of free fermions. Those models do not saturate the supersymmetric unitarity bound $h^R \geq c/24$ in general except the cases discussed in the previous section. For instance, let us consider a tensor product of the (bosonic) \mathfrak{a}_1 WZW model with level k and three free Majorana fermions. Although the model is known to preserve the $\mathcal{N} = 1$ supersymmetry, the Ramond vacuum energy is greater than $c/24$, i.e., the bound is not saturated for any k .

Table 8. The non-BPS type I involves nine non-BPS solutions which are obtained by imposing no free fermions and $h^{\text{NS}} \neq 1/2$. The GSO projection of the solutions with $c = 133/10, 91/5$ and $39/2$ leads to the WZW models for $\widehat{E}_{7,2}, \widehat{D}_{7,3}, \widehat{E}_{6,4}$, respectively. On the other hand, the identification for the solutions with $c = 102/5, 85/4, 22$ and $114/5$ remains unclear.

c	$\frac{7}{10}$	$\frac{133}{10}$	$\frac{91}{5}$	$\frac{39}{2}$	$\frac{102}{5}$	21	$\frac{85}{4}$	22	$\frac{114}{5}$
h^{NS}	$\frac{1}{10}$	$\frac{9}{10}$	$\frac{11}{10}$	$\frac{7}{6}$	$\frac{6}{5}$	$\frac{5}{4}$	$\frac{5}{4}$	$\frac{4}{3}$	$\frac{7}{5}$
h^{R}	$\frac{3}{80}, \frac{7}{16}$	$\frac{57}{80}, \frac{21}{16}$	$\frac{49}{40}, \frac{13}{8}$	$\frac{65}{48}, \frac{27}{16}$	$\frac{3}{2}, \frac{17}{10}$	$\frac{3}{2}, \frac{7}{4}$	$\frac{51}{32}, \frac{55}{32}$	$\frac{3}{2}, \frac{11}{6}$	$\frac{3}{2}, \frac{19}{10}$
\mathcal{M}	1	1	1	2	1	1	1	2	1

Although the space of solutions which contain free fermions but do not saturate the supersymmetric unitarity bound deserves further investigation, we restrict our attention in the present work to a simpler problem of classifying the fermionic RCFTs with no free fermion where $h^{\text{R}} > c/24$.

5.4.1. *Non-BPS type I: Non-BPS solutions without free fermions*

In this subsection, we explore the solutions of the second-order MLDE with $a_1 = 0$ and $h^{\text{NS}} \neq 1/2$. We refer to such solutions as the non-BPS solutions because they do not saturate the supersymmetric unitarity bound (79). The central charge and weights for the solutions in this class are summarized in Table 8. The q -series of the solutions are also given in Tables C5 and C6 for convenience. However, it turns out that the solutions with $c = 102/5, 21$, and $85/4$ have negative fusion coefficients and thus cannot be regarded as well-defined physical models. For the rest, the corresponding fermionic CFTs are identified in what follows.

Tricritical Ising model Let us first start with the solution with $c = 7/10$. One can show that the solution describes the fermionization of the unitary minimal model $\mathcal{M}(5, 4)$, namely the tricritical Ising model. Note that the model has six characters of weight,

$$h = \left\{ 0, \frac{3}{2}, \frac{1}{10}, \frac{3}{5}, \frac{3}{80}, \frac{7}{16} \right\}, \tag{160}$$

denoted by $\chi_h(\tau)$. Then, the solution of $c = 7/10$ can be written as

$$\begin{aligned} f_0^{\text{NS}}(\tau) &= \chi_0(\tau) + \chi_{\frac{3}{2}}(\tau), \\ f_1^{\text{NS}}(\tau) &= \chi_{\frac{1}{10}}(\tau) + \chi_{\frac{3}{5}}(\tau), \end{aligned} \tag{161}$$

and the characters of other sectors are given by

$$\begin{aligned} f_0^{\widetilde{\text{NS}}}(\tau) &= \chi_0(\tau) - \chi_{\frac{3}{2}}(\tau), \quad f_1^{\widetilde{\text{NS}}}(\tau) = \chi_{\frac{1}{10}}(\tau) - \chi_{\frac{3}{5}}(\tau), \\ f_0^{\text{R}}(\tau) &= \sqrt{2}\chi_{\frac{3}{80}}(\tau), \quad f_1^{\text{R}}(\tau) = \sqrt{2}\chi_{\frac{7}{16}}(\tau). \end{aligned} \tag{162}$$

In terms of the above characters, the torus partition functions for various spin structures become

$$\begin{aligned} Z_{\text{NS}}(\tau, \bar{\tau}) &= \left| f_0^{\text{NS}}(\tau) \right|^2 + \left| f_1^{\text{NS}}(\tau) \right|^2, \\ Z_{\widetilde{\text{NS}}}(\tau, \bar{\tau}) &= \left| f_0^{\widetilde{\text{NS}}}(\tau) \right|^2 + \left| f_1^{\widetilde{\text{NS}}}(\tau) \right|^2, \\ Z_{\text{R}}(\tau, \bar{\tau}) &= \left| f_0^{\text{R}}(\tau) \right|^2 + \left| f_1^{\text{R}}(\tau) \right|^2. \end{aligned} \tag{163}$$

Assuming $Z_{\tilde{R}}(\tau, \bar{\tau}) = 0$, we can see that the GSO projection of the fermionic CFT of our interest leads to the tricritical Ising model,

$$\begin{aligned} Z(\tau, \bar{\tau}) &= \frac{1}{2} \left[Z_{\text{NS}}(\tau, \bar{\tau}) + Z_{\tilde{\text{NS}}}(\tau, \bar{\tau}) + Z_{\text{R}}(\tau, \bar{\tau}) + Z_{\tilde{\text{R}}}(\tau, \bar{\tau}) \right] \\ &= \left| \chi_0(\tau) \right|^2 + \left| \chi_{\frac{3}{2}}(\tau) \right|^2 + \left| \chi_{\frac{1}{10}}(\tau) \right|^2 + \left| \chi_{\frac{3}{5}}(\tau) \right|^2 + \left| \chi_{\frac{3}{80}}(\tau) \right|^2 + \left| \chi_{\frac{7}{16}}(\tau) \right|^2. \end{aligned}$$

The tricritical Ising model is known to preserve the $\mathcal{N} = 1$ supersymmetry, but has the Ramond ground state which breaks the supersymmetry spontaneously [51]. This justifies our assumption $Z_{\tilde{R}}(\tau, \bar{\tau}) = 0$. We also note that the solution with $c = 7/10$ simply corresponds to the characters of the first unitary $\mathcal{N} = 1$ supersymmetric minimal model $\mathcal{SM}(5, 3)$.

ϵ_7 WZW model with level two We next move on to the solution of $c = 133/10$. We claim that the bosonization of the fermionic CFT results in the level-two WZW model for ϵ_7 . To see this, let us first note that the NS, $\tilde{\text{NS}}$ and R sector characters can be expressed in terms of the WZW characters:

$$\begin{aligned} f_0^{\text{NS}}(\tau) &= \chi_0^{\epsilon_{7,2}}(\tau) + \chi_{\frac{3}{2}}^{\epsilon_{7,2}}(\tau), \\ f_1^{\text{NS}}(\tau) &= \chi_{\frac{9}{10}}^{\epsilon_{7,2}}(\tau) + \chi_{\frac{7}{5}}^{\epsilon_{7,2}}(\tau), \end{aligned} \tag{164}$$

and

$$\begin{aligned} f_0^{\tilde{\text{NS}}}(\tau) &= \chi_0^{\epsilon_{7,2}}(\tau) - \chi_{\frac{3}{2}}^{\epsilon_{7,2}}(\tau), \\ f_1^{\tilde{\text{NS}}}(\tau) &= \chi_{\frac{9}{10}}^{\epsilon_{7,2}}(\tau) - \chi_{\frac{7}{5}}^{\epsilon_{7,2}}(\tau). \end{aligned} \tag{165}$$

The two solutions in the Ramond sector become

$$\tilde{f}_0^{\text{R}}(\tau) = \sqrt{2} \chi_{\frac{21}{16}}^{\epsilon_{7,2}}(\tau), \quad \tilde{f}_1^{\text{R}}(\tau) = \sqrt{2} \chi_{\frac{57}{80}}^{\epsilon_{7,2}}(\tau), \tag{166}$$

where we can see that the Ramond vacuum energy does not saturate the bound (79). The torus partition function for each spin structure is given by

$$\begin{aligned} Z_{\text{NS}}(\tau, \bar{\tau}) &= \left| f_0^{\text{NS}}(\tau) \right|^2 + \left| f_1^{\text{NS}}(\tau) \right|^2, \\ Z_{\tilde{\text{NS}}}(\tau, \bar{\tau}) &= \left| f_0^{\tilde{\text{NS}}}(\tau) \right|^2 + \left| f_1^{\tilde{\text{NS}}}(\tau) \right|^2, \\ Z_{\text{R}}(\tau, \bar{\tau}) &= \left| f_0^{\text{R}}(\tau) \right|^2 + \left| f_1^{\text{R}}(\tau) \right|^2. \end{aligned} \tag{167}$$

Under the assumption that $Z_{\tilde{R}}(\tau, \bar{\tau}) = 0$, one obtains the modular invariant partition function of the level-two WZW model for ϵ_7 via the GSO projection,

$$\begin{aligned} Z(\tau, \bar{\tau}) &= \frac{1}{2} \left[Z_{\text{NS}}(\tau, \bar{\tau}) + Z_{\tilde{\text{NS}}}(\tau, \bar{\tau}) + Z_{\text{R}}(\tau, \bar{\tau}) + Z_{\tilde{\text{R}}}(\tau, \bar{\tau}) \right] \\ &= \left| \chi_0^{\epsilon_{7,2}}(\tau) \right|^2 + \left| \chi_{\frac{3}{2}}^{\epsilon_{7,2}}(\tau) \right|^2 + \left| \chi_{\frac{1}{10}}^{\epsilon_{7,2}}(\tau) \right|^2 + \left| \chi_{\frac{3}{5}}^{\epsilon_{7,2}}(\tau) \right|^2 + \left| \chi_{\frac{21}{16}}^{\epsilon_{7,2}}(\tau) \right|^2 + \left| \chi_{\frac{57}{80}}^{\epsilon_{7,2}}(\tau) \right|^2. \end{aligned}$$

This result suggests that the fermionic description of the level-two WZW model for ϵ_7 preserves the supersymmetry but has a non-supersymmetric Ramond ground state. We leave this problem of verifying the emergent supersymmetry as a future work.

As a side remark, it turns out that the solutions of $c = 133/10$ are paired up with the characters of the first unitary $\mathcal{N} = 1$ supersymmetric minimal model to produce the $(\widehat{E}_{7,1})^{\otimes 2}$ WZW model, in the same way that the Ising model pairs up with the ϵ_8 WZW model at level two to give $(\widehat{E}_{8,1})^{\otimes 2}$. Precisely, the bilinear relations read

$$\begin{aligned} \left(\chi_0^{\epsilon_{7,1}}(\tau)\right)^2 + \left(\chi_{\frac{3}{4}}^{\epsilon_{7,1}}(\tau)\right)^2 &= f_0^{\text{NS}}(\tau)\tilde{f}_0^{\text{NS}}(\tau) + f_1^{\text{NS}}(\tau)\tilde{f}_1^{\text{NS}}(\tau), \\ \left(\chi_0^{\epsilon_{7,1}}(\tau)\right)^2 - \left(\chi_{\frac{3}{4}}^{\epsilon_{7,1}}(\tau)\right)^2 &= f_0^{\widetilde{\text{NS}}}(\tau)\tilde{f}_0^{\widetilde{\text{NS}}}(\tau) + f_1^{\widetilde{\text{NS}}}(\tau)\tilde{f}_1^{\widetilde{\text{NS}}}(\tau), \\ \left(\chi_0^{\epsilon_{7,1}}(\tau)\chi_{\frac{3}{4}}^{\epsilon_{7,1}}(\tau)\right)^2 &= f_0^{\text{R}}(\tau)\tilde{f}_0^{\text{R}}(\tau) + f_1^{\text{R}}(\tau)\tilde{f}_1^{\text{R}}(\tau), \end{aligned} \tag{168}$$

where $\chi_h^{\epsilon_{7,1}}(\tau)$ means the characters of the ϵ_7 WZW model at level one.

Orbifold of \mathfrak{d}_7 WZW model with level three We observe that the NS solutions with $c = 91/5$ can be expressed in terms of the characters of the level-three WZW model for \mathfrak{d}_7 as

$$\begin{aligned} f_0^{\text{NS}}(\tau) &= \chi_0^{\mathfrak{d}_{7,3}}(\tau) + \chi_2^{\mathfrak{d}_{7,3}}(\tau) + \chi_{\frac{3}{2}}^{\mathfrak{d}_{7,3}}(\tau) + \widetilde{\chi}_{\frac{3}{2}}^{\mathfrak{d}_{7,3}}(\tau), \\ f_1^{\text{NS}}(\tau) &= \chi_{\frac{11}{10}}^{\mathfrak{d}_{7,3}}(\tau) + \chi_{\frac{21}{10}}^{\mathfrak{d}_{7,3}}(\tau) + \chi_{\frac{8}{5}}^{\mathfrak{d}_{7,3}}(\tau) + \widetilde{\chi}_{\frac{8}{5}}^{\mathfrak{d}_{7,3}}(\tau), \end{aligned} \tag{169}$$

where $\chi_{\frac{3}{2}}^{\mathfrak{d}_{7,3}}(\tau)$ and $\widetilde{\chi}_{\frac{3}{2}}^{\mathfrak{d}_{7,3}}(\tau)$ ($\chi_{\frac{8}{5}}^{\mathfrak{d}_{7,3}}(\tau)$ and $\widetilde{\chi}_{\frac{8}{5}}^{\mathfrak{d}_{7,3}}(\tau)$) are characters of the same weight $h = 3/2$ ($h = 8/5$) but in different representations under \mathfrak{d}_7 . Performing S and T transformations on them, the solutions for other sectors are given as

$$\begin{aligned} f_0^{\widetilde{\text{NS}}}(\tau) &= \chi_0^{\mathfrak{d}_{7,3}}(\tau) + \chi_2^{\mathfrak{d}_{7,3}}(\tau) - \chi_{\frac{3}{2}}^{\mathfrak{d}_{7,3}}(\tau) - \widetilde{\chi}_{\frac{3}{2}}^{\mathfrak{d}_{7,3}}(\tau), \\ f_1^{\widetilde{\text{NS}}}(\tau) &= \chi_{\frac{11}{10}}^{\mathfrak{d}_{7,3}}(\tau) + \chi_{\frac{21}{10}}^{\mathfrak{d}_{7,3}}(\tau) - \chi_{\frac{8}{5}}^{\mathfrak{d}_{7,3}}(\tau) - \widetilde{\chi}_{\frac{8}{5}}^{\mathfrak{d}_{7,3}}(\tau), \end{aligned} \tag{170}$$

and

$$f_0^{\text{R}}(\tau) = 2\left(\chi_{\frac{49}{40}}^{\mathfrak{d}_{7,3}}(\tau) + \chi_{\frac{89}{40}}^{\mathfrak{d}_{7,3}}(\tau)\right), \tag{171}$$

$$f_1^{\text{R}}(\tau) = 2\left(\chi_{\frac{13}{8}}^{\mathfrak{d}_{7,3}}(\tau) + \chi_{\frac{21}{8}}^{\mathfrak{d}_{7,3}}(\tau)\right). \tag{172}$$

We propose the vanishing $Z_{\widetilde{\text{R}}}(\tau, \bar{\tau})$ so that the bosonization of the fermionic RCFT with $c = 91/5$ provides the non-diagonal modular invariant partition function of the \mathfrak{d}_7 WZW model with level three;

$$\begin{aligned} Z(\tau, \bar{\tau}) &= \frac{1}{2}\left[Z_{\text{NS}}(\tau, \bar{\tau}) + Z_{\widetilde{\text{NS}}}(\tau, \bar{\tau}) + Z_{\text{R}}(\tau, \bar{\tau}) + Z_{\widetilde{\text{R}}}(\tau, \bar{\tau})\right] \\ &= \left|\chi_0^{\mathfrak{d}_{7,3}} + \chi_2^{\mathfrak{d}_{7,3}}\right|^2 + \left|\chi_{\frac{3}{2}}^{\mathfrak{d}_{7,3}} + \widetilde{\chi}_{\frac{3}{2}}^{\mathfrak{d}_{7,3}}\right|^2 + \left|\chi_{\frac{11}{10}}^{\mathfrak{d}_{7,3}} + \chi_{\frac{21}{10}}^{\mathfrak{d}_{7,3}}\right|^2 + \left|\chi_{\frac{8}{5}}^{\mathfrak{d}_{7,3}} + \widetilde{\chi}_{\frac{8}{5}}^{\mathfrak{d}_{7,3}}\right|^2 \\ &\quad + 2\left|\chi_{\frac{49}{40}}^{\mathfrak{d}_{7,3}} + \chi_{\frac{89}{40}}^{\mathfrak{d}_{7,3}}\right|^2 + 2\left|\chi_{\frac{13}{8}}^{\mathfrak{d}_{7,3}} + \chi_{\frac{21}{8}}^{\mathfrak{d}_{7,3}}\right|^2. \end{aligned} \tag{173}$$

Each multiplicity 2 in Eq. (173) means that two primaries in different representations under \mathfrak{d}_7 are associated with the same character. We expect that a certain orbifold of the \mathfrak{d}_7 WZW model with level three has Eq. (173) as the diagonal modular invariant partition function. From the Verlinde formula, one can verify that the orbifold model has a consistent fusions algebra. This result is tantalizing, in that the fermionic RCFT of $c = 91/5$ has an emergent supersymmetry but no supersymmetric vacuum, which can explain why $Z_{\widetilde{R}}(\tau, \bar{\tau})$ vanishes.

Orbifold of ϵ_6 WZW model with level four Similarly, one can express the solutions with $c = 39/2$ in terms of the characters of the level-four WZW model for ϵ_6 as

$$\begin{aligned} f_0^{\text{NS}}(\tau) &= \chi_0^{\epsilon_{6,4}}(\tau) + \chi_2^{\epsilon_{6,4}}(\tau) + \chi_{\frac{3}{2}}^{\epsilon_{6,4}}(\tau) + \chi_{\frac{5}{2}}^{\epsilon_{6,4}}(\tau), \\ f_1^{\text{NS}}(\tau) &= \chi_{\frac{7}{6}}^{\epsilon_{6,4}}(\tau) + \chi_{\frac{13}{6}}^{\epsilon_{6,4}}(\tau) + \chi_{\frac{5}{3}}^{\epsilon_{6,4}}(\tau) + \chi_{\frac{8}{3}}^{\epsilon_{6,4}}(\tau), \\ f_0^{\widetilde{\text{NS}}}(\tau) &= \chi_0^{\epsilon_{6,4}}(\tau) + \chi_2^{\epsilon_{6,4}}(\tau) - \chi_{\frac{3}{2}}^{\epsilon_{6,4}}(\tau) - \chi_{\frac{5}{2}}^{\epsilon_{6,4}}(\tau), \\ f_1^{\widetilde{\text{NS}}}(\tau) &= \chi_{\frac{7}{6}}^{\epsilon_{6,4}}(\tau) + \chi_{\frac{13}{6}}^{\epsilon_{6,4}}(\tau) - \chi_{\frac{5}{3}}^{\epsilon_{6,4}}(\tau) - \chi_{\frac{8}{3}}^{\epsilon_{6,4}}(\tau), \end{aligned} \tag{174}$$

and

$$f_0^{\text{R}}(\tau) = 2\left(\chi_{\frac{65}{48}}^{\epsilon_{6,4}}(\tau) + \chi_{\frac{113}{48}}^{\epsilon_{6,4}}(\tau)\right), \quad f_1^{\text{R}}(\tau) = 2\chi_{\frac{27}{16}}^{\epsilon_{6,4}}(\tau). \tag{175}$$

The modular matrices then determine the torus partition functions for various spin structures,

$$\begin{aligned} Z_{\text{NS}}(\tau, \bar{\tau}) &= \left| \chi_0^{\epsilon_{6,4}} + \chi_2^{\epsilon_{6,4}} + \chi_{\frac{3}{2}}^{\epsilon_{6,4}} + \chi_{\frac{5}{2}}^{\epsilon_{6,4}} \right|^2 + 2 \left| \chi_{\frac{7}{6}}^{\epsilon_{6,4}} + \chi_{\frac{13}{6}}^{\epsilon_{6,4}} + \chi_{\frac{5}{3}}^{\epsilon_{6,4}} + \chi_{\frac{8}{3}}^{\epsilon_{6,4}} \right|^2, \\ Z_{\widetilde{\text{NS}}}(\tau, \bar{\tau}) &= \left| \chi_0^{\epsilon_{6,4}} + \chi_2^{\epsilon_{6,4}} - \chi_{\frac{3}{2}}^{\epsilon_{6,4}} - \chi_{\frac{5}{2}}^{\epsilon_{6,4}} \right|^2 + 2 \left| \chi_{\frac{7}{6}}^{\epsilon_{6,4}} + \chi_{\frac{13}{6}}^{\epsilon_{6,4}} - \chi_{\frac{5}{3}}^{\epsilon_{6,4}} - \chi_{\frac{8}{3}}^{\epsilon_{6,4}} \right|^2, \\ Z_{\text{R}}(\tau, \bar{\tau}) &= 4 \left| \chi_{\frac{65}{48}}^{\epsilon_{6,4}} + \chi_{\frac{113}{48}}^{\epsilon_{6,4}} \right|^2 + 8 \left| \chi_{\frac{27}{16}}^{\epsilon_{6,4}} \right|^2. \end{aligned} \tag{176}$$

We again suppose that the fermionic model of our interest has vanishing $Z_{\widetilde{R}}(\tau, \bar{\tau})$. As a consequence, the GSO projection leads to

$$\begin{aligned} Z(\tau, \bar{\tau}) &= \frac{1}{2} \left[Z_{\text{NS}}(\tau, \bar{\tau}) + Z_{\widetilde{\text{NS}}}(\tau, \bar{\tau}) + Z_{\text{R}}(\tau, \bar{\tau}) + Z_{\widetilde{\text{R}}}(\tau, \bar{\tau}) \right] \\ &= \left| \chi_0^{\epsilon_{6,4}} + \chi_2^{\epsilon_{6,4}} \right|^2 + \left| \chi_{\frac{3}{2}}^{\epsilon_{6,4}} + \chi_{\frac{5}{2}}^{\epsilon_{6,4}} \right|^2 + 2 \left| \chi_{\frac{7}{6}}^{\epsilon_{6,4}} + \chi_{\frac{13}{6}}^{\epsilon_{6,4}} \right|^2 + 2 \left| \chi_{\frac{5}{3}}^{\epsilon_{6,4}} + \chi_{\frac{8}{3}}^{\epsilon_{6,4}} \right|^2 \\ &\quad + 2 \left| \chi_{\frac{65}{48}}^{\epsilon_{6,4}} + \chi_{\frac{113}{48}}^{\epsilon_{6,4}} \right|^2 + 4 \left| \chi_{\frac{27}{16}}^{\epsilon_{6,4}} \right|^2, \end{aligned} \tag{177}$$

which is a non-diagonal modular invariant partition function of the level-four ϵ_6 WZW models. In the ϵ_6 WZW model, some pairs of primaries in different representations share the same character. For instance, this happens for the characters of weight $7/6, 13/6, 5/3, 8/3, 65/48, 113/48$ and $27/16$. It is likely that a certain orbifold of the WZW model would have Eq. (177) as the diagonal modular invariant partition function. We also propose that the fermionic RCFT with $c = 39/2$ preserves the supersymmetry, but its Ramond vacuum breaks the supersymmetry spontaneously.

The solutions with $c = 114/5$ and 21 Let us consider the solutions with $c = 114/5$ and $c = 21$. We first make the conjecture that under the assumption of vanishing $Z_{\tilde{R}}(\tau, \bar{\tau})$, the solutions with $c = 114/5$ describe the fermionization of the bosonic RCFT exhibiting the moonshine phenomena for $2.^2E_6(2).2$ [17]. More precisely, the NS, \tilde{NS} and R sector solutions can be expressed as

$$\begin{aligned} f_0^{\text{NS}}(\tau) &= \tilde{\chi}_0(\tau) + \tilde{\chi}_2(\tau), & f_1^{\text{NS}}(\tau) &= \tilde{\chi}_1(\tau) + \tilde{\chi}_5(\tau), \\ f_0^{\tilde{\text{NS}}}(\tau) &= \tilde{\chi}_0(\tau) - \tilde{\chi}_2(\tau), & f_1^{\tilde{\text{NS}}}(\tau) &= \tilde{\chi}_1(\tau) - \tilde{\chi}_5(\tau), \\ f_0^{\text{R}}(\tau) &= 2\tilde{\chi}_2(\tau), & f_1^{\text{R}}(\tau) &= 2\tilde{\chi}_5(\tau). \end{aligned} \tag{178}$$

Here $\tilde{\chi}_i(\tau)$ are the characters of putative bosonic RCFT with $c = 114/5$ and their explicit forms are given in equation (3.55) of Ref. [17]. Let us combine the partition functions for the NS, \tilde{NS} and R sectors;

$$\begin{aligned} Z(\tau, \bar{\tau}) &= \frac{1}{2}Z^{\text{NS}}(\tau, \bar{\tau}) + \frac{1}{2}Z^{\tilde{\text{NS}}}(\tau, \bar{\tau}) + \frac{1}{2}Z^{\text{R}}(\tau, \bar{\tau}) \\ &= |\tilde{\chi}_0(\tau)|^2 + |\tilde{\chi}_1(\tau)|^2 + 3|\tilde{\chi}_2(\tau)|^2 + 3|\tilde{\chi}_5(\tau)|^2, \end{aligned} \tag{179}$$

thus the GSO projection reproduce the modular invariant partition function of the hypothetical bosonic RCFT with $c = 114/5$ with the assumption of $Z^{\tilde{R}} = 0$.

We finally comment that the solutions of $c = 21$ admits the linear group $2^9.L_3(4)$ as an automorphism group. This can be shown with the help of a rank 21 lattice that constructed in Ref. [52]. We will discuss more details of this theory in an upcoming paper [33].

5.4.2. Non-BPS type II: Non-BPS pairs with $h^{\text{NS}} = 1/2$

Here we discuss the solutions obtained by imposing the two conditions $h^{\text{NS}} = 1/2$ and $a_1 = 0$. There are seven solutions in this class which have non-negative integers in q -series. The profiles of the seven solutions are listed in Table 9 and their explicit q -series are presented in Tables C7 and C8. The R sector conformal weights are given by $h_-^{\text{R}} = \frac{c-4}{8}$ and $h_+^{\text{R}} = \frac{c}{8}$. Note that the $\mathcal{N} = 1$ unitarity bound is violated for $c < 6$, because $h_-^{\text{R}} = \frac{c-4}{8} < c/24$. Therefore the theories with $c < 6$ in this class cannot be unitary $\mathcal{N} = 1$ supersymmetric CFTs. The unitarity bound is saturated for the solution of $c = 6$ and it agrees with the self-dual solution in BPS type I. As discussed before, the solution with $c = 6$ can be understood as a hexic product of the $su(2)_1$ WZW model and we will not discuss it any further in this article.

The NS sector characters take the analytic form of

$$\begin{aligned} f_0^{\text{NS}}(\tau) &= (\psi^{\text{NS}})^{2c} - 2c(\psi^{\text{NS}})^{2c-24} \left(\frac{\vartheta_3(\tau)}{\vartheta_4(\tau)} \right)^4 = (\psi^{\text{NS}})^{2c} \left(1 - \frac{c\lambda}{8} \right), \\ f_1^{\text{NS}}(\tau) &= b_0(\psi^{\text{NS}})^{2c-24} \left(\frac{\vartheta_3(\tau)}{\vartheta_4(\tau)} \right)^4 = b_0(\psi^{\text{NS}})^{2c} \frac{\lambda}{16}, \end{aligned} \tag{180}$$

where the central charge c is constrained between $4 \leq c \leq 15/2$ to have non-negative integer coefficients in the q -series. Because Eq. (180) reduces to the characters of a level-one WZW model for \mathfrak{d}_4 when $c = 4$, we only focus on the solutions between $9/2 \leq c \leq 15/2$ to explore the fermionic RCFT. Now it is straightforward to see that the two characters $f_0^{\text{NS}}(\tau)$ and $f_1^{\text{NS}}(\tau)$ satisfy the identity

Table 9. The seven solutions obtained by imposing two conditions $h^{\text{NS}} = 1/2$ and $a_1 = 0$. The solution of $c = 6$ saturates the unitarity bound, hence it is also found in the BPS type I. In this table, b_0 denotes a coefficient of the leading-order term of the NS sector non-degenerate solution. \mathcal{M} denotes a degeneracy of the NS sector primary state. a'_0 and b'_0 stand for the leading-order coefficients of the R sector solutions.

c	$\frac{9}{2}$	5	$\frac{11}{2}$	6	$\frac{13}{2}$	7	$\frac{15}{2}$
h^{NS}	$\frac{1}{2}$	$\frac{1}{2}$	$\frac{1}{2}$	$\frac{1}{2}$	$\frac{1}{2}$	$\frac{1}{2}$	$\frac{1}{2}$
h^{R}	$\frac{1}{16}, \frac{9}{16}$	$\frac{1}{8}, \frac{5}{8}$	$\frac{3}{16}, \frac{11}{16}$	$\frac{1}{4}, \frac{3}{4}$	$\frac{5}{16}, \frac{13}{16}$	$\frac{3}{8}, \frac{7}{8}$	$\frac{7}{16}, \frac{15}{16}$
b_0	1	2	1	4	1	6	1
\mathcal{M}	207	55	231	15	247	7	255
a'_0	1	1	1	2	2	4	4
b'_0	1	8	8	8	16	96	32

$$f_0^{\text{NS}}(\tau) + \frac{2c}{b_0} f_1^{\text{NS}}(\tau) = (\psi^{\text{NS}})^{2c}, \tag{181}$$

where ψ^{NS} denotes the NS partition function of a free Majorana–Weyl fermion as introduced in Eq. (70). This identity indicates that two independent solutions in non-BPS type II split the partition function of the $n = 2c$ tensor product of the free Majorana–Weyl fermions. The vacuum solution $f_0^{\text{NS}}(\tau)$ does not involve free fermion currents because $\lambda \sim 16q^{1/2}$, thus it satisfies the condition $a_1 = 0$.

The S transformation of the vacuum solution ought to be written as a linear combination of $f_0^{\text{NS}}(\tau)$ and $f_1^{\text{NS}}(\tau)$. Therefore, $f_0^{\text{NS}}(\tau)/(\psi^{\text{NS}})^{2c}$ should be a linear polynomial of λ . With the help of the analytic expression (180), one can read the S -transformation rule for $f_0^{\text{NS}}(\tau)$ and $f_1^{\text{NS}}(\tau)$;

$$\begin{pmatrix} f_0^{\text{NS}}(-\frac{1}{\tau}) \\ f_1^{\text{NS}}(-\frac{1}{\tau}) \end{pmatrix} = \frac{1}{16} \begin{pmatrix} 16 - 2c & \frac{1}{b_0}(64c - 4c^2) \\ b_0 & (2c - 16) \end{pmatrix} \begin{pmatrix} f_0^{\text{NS}}(\tau) \\ f_1^{\text{NS}}(\tau) \end{pmatrix}. \tag{182}$$

We demand $64c - 4c^2 > 0$ to have a symmetric extended matrix, thus c should be smaller than 16. This constraint is automatically satisfied since we focus on the solutions between $9/2 \leq c \leq 15/2$. For this case, one can show that the NS sector partition function takes the form of

$$Z_{\text{NS}}(\tau, \bar{\tau}) = f_0^{\text{NS}}(\tau) \bar{f}_0^{\text{NS}}(\bar{\tau}) + \frac{4c(16 - c)}{b_0^2} f_1^{\text{NS}}(\tau) \bar{f}_1^{\text{NS}}(\bar{\tau}) \tag{183}$$

using the S -matrix (182).

We now discuss the bilinear relation which is satisfied by the NS sector solutions in this class. Let us take the following three pairs of the non-BPS type II solutions:

$$(c, \tilde{c} = 12 - c) = \left(\frac{9}{2}, \frac{15}{2}\right), \quad (5, 7), \quad \left(\frac{11}{2}, \frac{13}{2}\right). \tag{184}$$

Using the analytic expression of the solutions (180), we arrive at the following bilinear relation:

$$f_0^{\text{NS}} \tilde{f}_0^{\text{NS}} + m f_1^{\text{NS}} \tilde{f}_1^{\text{NS}} = (\psi^{\text{NS}})^{24} - 24 + \left(\frac{4c(12 - c) + m b_0 \tilde{b}_0}{16} - 24 \right) \frac{\lambda}{1 - \lambda}$$

$$= K(\tau) + \left(\frac{4c(12 - c) + mb_0\tilde{b}_0}{16} - 24 \right) \frac{\lambda}{1 - \lambda}. \tag{185}$$

In the above relation, $(\tilde{f}_0^{\text{NS}}, \tilde{f}_1^{\text{NS}})$ denotes the dual pair of $(f_0^{\text{NS}}, f_1^{\text{NS}})$. Also, b_0 and \tilde{b}_0 stand for the normalization constant of the solutions f_1^{NS} and \tilde{f}_1^{NS} , respectively. When the constant m satisfies the constraint $m = [4(96 - 12c + c^2)]/(b_0\tilde{b}_0)$, the right-hand side of Eq. (185) simply becomes $K(\tau)$. Assuming this constraint is satisfied, the duality relations for the three pairs (184) are given by

$$\begin{aligned} K(\tau) &= f_0^{\text{NS}}(q)\tilde{f}_0^{\text{NS}}(q) + 249f_1^{\text{NS}}(q)\tilde{f}_1^{\text{NS}}(q), \quad \text{for } c = \frac{9}{2}, \\ K(\tau) &= f_0^{\text{NS}}(q)\tilde{f}_0^{\text{NS}}(q) + \frac{61}{3}f_1^{\text{NS}}(q)\tilde{f}_1^{\text{NS}}(q), \quad \text{for } c = 5, \\ K(\tau) &= f_0^{\text{NS}}(q)\tilde{f}_0^{\text{NS}}(q) + 241f_1^{\text{NS}}(q)\tilde{f}_1^{\text{NS}}(q), \quad \text{for } c = \frac{11}{2}. \end{aligned} \tag{186}$$

Let us turn our attention to the $\tilde{\text{NS}}$ and R sector solutions. To this end, we apply T and ST transformation to Eq. (180). First we note that the character of a single free fermion for the $\tilde{\text{NS}}$ and R sectors can be obtained as follows:

$$\psi^{\tilde{\text{NS}}}(\tau) \equiv \psi^{\text{NS}}(\tau + 1) = \frac{\eta(\frac{\tau}{2})}{\eta(\tau)}, \quad \psi^{\text{R}}(\tau) \equiv \psi^{\text{NS}}\left(-\frac{1}{\tau} + 1\right) = \sqrt{2} \frac{\eta(2\tau)}{\eta(\tau)}. \tag{187}$$

Since the λ variable is mapped to $\frac{\lambda}{\lambda-1}$ and $\frac{\lambda-1}{\lambda}$ under the T and ST transformation, respectively, the $\tilde{\text{NS}}$ and R sector characters can be expressed as

$$\begin{aligned} f_0^{\tilde{\text{NS}}}(\tau) &= \left(1 + \frac{c}{8} \frac{\lambda}{1 - \lambda}\right) (\psi^{\tilde{\text{NS}}})^{2c}, & f_1^{\tilde{\text{NS}}}(\tau) &= b_0 \frac{1}{16} \frac{\lambda}{1 - \lambda} (\psi^{\tilde{\text{NS}}})^{2c}, \\ f_0^{\text{R}}(\tau) &= a'_0 \frac{2^{3-c}(2 - \lambda)}{\lambda} (\psi^{\text{R}})^{2c}, & f_1^{\text{R}}(\tau) &= 2^{-c} b'_0 (\psi^{\text{R}})^{2c}, \end{aligned} \tag{188}$$

and their q -series agree with that of the Table C8 with suitable choice of a'_0 and b'_0 . From Eq. (188), the modular transformation rules for the $\tilde{\text{NS}}$ and R sector characters read

$$\begin{aligned} \begin{pmatrix} f_0^{\tilde{\text{NS}}}(-\frac{1}{\tau}) \\ f_1^{\tilde{\text{NS}}}(-\frac{1}{\tau}) \end{pmatrix} &= 2^{c-8} \begin{pmatrix} 2c/a'_0 & 16(16 - c)/b'_0 \\ b_0/a'_0 & -8b_0/b'_0 \end{pmatrix} \begin{pmatrix} f_0^{\text{R}}(\tau) \\ f_1^{\text{R}}(\tau) \end{pmatrix}, \\ \begin{pmatrix} f_0^{\text{R}}(-\frac{1}{\tau}) \\ f_1^{\text{R}}(-\frac{1}{\tau}) \end{pmatrix} &= 2^{-c} \begin{pmatrix} 8a'_0 & 16(16 - c)a'_0/b_0 \\ b'_0 & -2cb'_0/b_0 \end{pmatrix} \begin{pmatrix} f_0^{\tilde{\text{NS}}}(\tau) \\ f_1^{\tilde{\text{NS}}}(\tau) \end{pmatrix}. \end{aligned} \tag{189}$$

Because the $\tilde{\text{NS}}$ sector partition function has a form of

$$Z_{\tilde{\text{NS}}}(\tau, \bar{\tau}) = |f_0^{\tilde{\text{NS}}}(\tau)|^2 + \frac{4c(16 - c)}{b'_0} |f_1^{\tilde{\text{NS}}}(\tau)|^2, \tag{190}$$

the R sector partition function is given by

$$\begin{aligned} Z_{\text{R}}(\tau, \bar{\tau}) &= Z_{\tilde{\text{NS}}}\left(-\frac{1}{\tau}, -\frac{1}{\bar{\tau}}\right) = \left|f_0^{\tilde{\text{NS}}}\left(-\frac{1}{\tau}\right)\right|^2 + \frac{4c(16 - c)}{b_0^2} \left|f_1^{\tilde{\text{NS}}}\left(-\frac{1}{\tau}\right)\right|^2 \\ &= \frac{2^{2c-10}c}{a_0'^2} |f_0^{\text{R}}(\tau)|^2 + \frac{2^{2c-4}(16 - c)}{b_0'^2} |f_1^{\text{R}}(\tau)|^2. \end{aligned} \tag{191}$$

Finally, let us comment on the normalization constants a'_0 and b'_0 . We choose integer a'_0 and b'_0 so as to satisfy $\sqrt{2^{2c-10}c} = a'_0\sqrt{\mathcal{M}_1}$ and $\sqrt{2^{2c-4}(16-c)} = b'_0\sqrt{\mathcal{M}_2}$, where $\mathcal{M}_1/n_1^2, \mathcal{M}_2/n_2^2 \notin \mathbb{Z}$ for any integer $n_1, n_2 > 1$. Then we absorb a'_0 and b'_0 into the R sector characters and consider \mathcal{M}_1 and \mathcal{M}_2 as related to the degeneracy of two characters in the R sector.

5.4.3. *Non-BPS type III: One-parameter family with $c = 16$*

The second-order MLDE exhibits infinitely many solutions of $c = 16$. Here we discuss a relation between these infinite solutions and the characters of the $c = 16$ bosonic RCFT without Kac–Moody symmetry that was discussed in Ref. [53]. The $c = 16$ bosonic theory of our interest involves the vacuum and two primaries of weight $h = 1/2, 1$. The three characters for the vacuum and primaries are known to have the following q -expansion:

$$\begin{aligned} f_{h=0}(q) &= q^{-2/3} (1 + 2296q^2 + 65536q^3 + 1085468q^4 + \dots), \\ f_{h=1}(q) &= q^{1/3} (1 + 136q + 4132q^2 + 67712q^3 + \dots), \\ f_{h=\frac{3}{2}}(q) &= q^{5/6} (1 + 52q + 1106q^2 + 14808q^3 + \dots). \end{aligned} \tag{192}$$

We find that the infinitely many solutions with $c = 16$ are a one-parameter family. More precisely, the solutions of non-BPS type III can be expressed as

$$\begin{aligned} f_0^{\text{NS}}(q) &= (f_{h=0}(q) + 256f_{h=\frac{3}{2}}(q)) + n(f_{h=1}(q) + 16f_{h=\frac{3}{2}}(q)), \quad n \in \mathbb{Z}_{\geq 0}, \\ f_1^{\text{NS}}(q) &= f_{h=1}(q) + 16f_{h=\frac{3}{2}}(q), \\ f_0^{\widetilde{\text{NS}}}(q) &= (f_{h=0}(q) - 256f_{h=\frac{3}{2}}(q)) + n(f_{h=1}(q) - 16f_{h=\frac{3}{2}}(q)), \quad n \in \mathbb{Z}_{\geq 0}, \\ f_1^{\widetilde{\text{NS}}}(q) &= f_{h=1}(q) - 16f_{h=\frac{3}{2}}(q), \quad f_0^{\text{R}}(q) = f_{h=1}(q), \quad f_1^{\text{R}}(\tau) = f_{h=\frac{3}{2}}(q). \end{aligned} \tag{193}$$

Let us see how the characters (193) form Γ_θ -invariant partition functions as well as the consistent fusion rule algebra. To this end, it is necessary to find the S -matrices of Eq. (193). Note that the characters (192) ought to solve the third-order differential equation with $\ell = 0$ [40],²

$$\begin{aligned} &\lambda^2(1-\lambda)^2\partial_\lambda^3\tilde{f}(\lambda) - (6\alpha_0 + 2)\lambda(1-\lambda)(2\lambda-1)\partial_\lambda^2\tilde{f}(\lambda) \\ &+ [12\alpha_0^2 + 2\alpha_0 + \nu_1 - 2 - \lambda(1-\lambda)(48\alpha_0^2 + 20\alpha_0 + \nu_1)]\partial_\lambda\tilde{f}(\lambda) \\ &+ [24\alpha_0^2 + 6(2-\nu_1)\alpha_0 - 9\nu_2](2\lambda-1)\tilde{f}(\lambda) = 0, \end{aligned} \tag{194}$$

where $\tilde{f}(\lambda) \equiv (\lambda(1-\lambda)/16)^{c/12}f(\lambda)$ and $\alpha_i = h_i - c/24$. The parameters ν_i are expressed in terms of α_i as

$$\nu_1 = 2 + 4\alpha_0\alpha_1 + 4\alpha_0\alpha_2 + 4\alpha_1\alpha_2, \quad \nu_2 = -4\alpha_0\alpha_1\alpha_2. \tag{195}$$

² We thank Sunil Mukhi for letting us know the analytic solution of the third-order MLDE for $SL_2(\mathbb{Z})$.

We find that the NS, $\widetilde{\text{NS}}$ and R sector characters can be expressed as a linear combination of the three independent solutions of Eq. (194) with $\alpha_0 = -2/3$, $\alpha_1 = -1/3$, $\alpha_2 = 1/6$. Explicitly,

$$\begin{aligned} f_{h=0}(q) &= \left(1 + \frac{1}{32}\lambda(\lambda^3 - 2\lambda^2 + 34\lambda - 64)\right) \left(\frac{\lambda(1-\lambda)}{16}\right)^{-\frac{4}{3}}, \\ f_{h=1}(q) &= \frac{1}{512}\lambda^2(\lambda^2 - 2\lambda + 2) \left(\frac{\lambda(1-\lambda)}{16}\right)^{-\frac{4}{3}}, \\ f_{h=\frac{3}{2}}(q) &= -\frac{\lambda^3(\lambda - 2)}{8192} \left(\frac{\lambda(1-\lambda)}{16}\right)^{-\frac{4}{3}}; \end{aligned} \tag{196}$$

thus the fermionic characters (193) can be written in terms of the λ variable.

Using the S transformation rule of the λ variable, i.e., $\lambda \rightarrow 1 - \lambda$, it is straightforward to read the S -matrices for the characters in the NS, $\widetilde{\text{NS}}$ and R sectors. We find that the NS sector characters are transformed as

$$\begin{pmatrix} f_0^{\text{NS}}(-\frac{1}{\tau}) \\ f_1^{\text{NS}}(-\frac{1}{\tau}) \end{pmatrix} = \frac{1}{256} \begin{pmatrix} (n+16) & -(n+272)(n-240) \\ 1 & -(n+16) \end{pmatrix} \begin{pmatrix} f_0^{\text{NS}}(\tau) \\ f_1^{\text{NS}}(\tau) \end{pmatrix}, \tag{197}$$

while the transformation rules for the $\widetilde{\text{NS}}$ and R sector characters read

$$\begin{aligned} \begin{pmatrix} f_0^{\widetilde{\text{NS}}}(-\frac{1}{\tau}) \\ f_1^{\widetilde{\text{NS}}}(-\frac{1}{\tau}) \end{pmatrix} &= \begin{pmatrix} (n+272) & -16(n-240) \\ 1 & -16 \end{pmatrix} \begin{pmatrix} f_0^{\text{R}}(\tau) \\ f_1^{\text{R}}(\tau) \end{pmatrix}, \\ \begin{pmatrix} f_0^{\text{R}}(-\frac{1}{\tau}) \\ f_1^{\text{R}}(-\frac{1}{\tau}) \end{pmatrix} &= \frac{1}{8192} \begin{pmatrix} 16 & -16(n-240) \\ 1 & -(n+272) \end{pmatrix} \begin{pmatrix} f_0^{\widetilde{\text{NS}}}(\tau) \\ f_1^{\widetilde{\text{NS}}}(\tau) \end{pmatrix}. \end{aligned} \tag{198}$$

There should be a symmetric extended matrix in order to have a consistent fusion rule algebra. If $n \geq 240$, the off-diagonal component becomes 0 or negative, thus one cannot find an extended matrix. In other words, the existence of the consistent fusion rule algebra constrains $n < 240$. This indicates that only a finite number of solutions have the consistent fusion rule algebra and can be considered as the characters of certain RCFTs.

5.4.4. Non-BPS type IV: Single-character theories

We now focus on the class of the single-character solutions. For the solutions in this class, the vacuum solutions are allowed to have non-negative integer coefficients. In contrast, the other solutions exhibit rational coefficients *with unbounded denominators*, thus we do not pay much attention to these solutions. We will show that the vacuum solutions of the non-BPS type IV are invariant under S transformation by themselves.

In principle, the single-character of our interest could appear as the solution of the first-order MLDE with higher ℓ . In some cases, the first-order MLDE can be lifted to a higher-order MLDE without poles and the single-character can be identified to the vacuum solution of the higher-order MLDE with $\ell = 0$. To illustrate this point, we revisit the character of $(\epsilon_8)_1$ WZW model. It has been argued that the character of this theory appears as a solution with non-negative integer coefficients

of the second-order MLDE [40]

$$\left(\mathcal{D}^2 - \frac{E_4}{6}\right)f = 0. \tag{199}$$

On the other hand, the other independent solution of the above MLDE is characterized by rational coefficients in the q -expansion, hence cannot be interpreted as a character of certain RCFT. Because the vacuum solution is modular-invariant by itself, the $(\epsilon_8)_1$ WZW model can be understood as a single-character theory with $f_0(\tau) = j^{1/3} = E_4/\eta^8$.

As a single character theory, the character $f_0(\tau)$ has to be solution to a first-order MLDE given in Ref. [8],

$$\left(\mathcal{D} + \frac{1}{3} \frac{E_6}{E_4}\right)f = 0, \tag{200}$$

where the Wronskian has a zero of order two. Given the equation (200), the identity

$$(\mathcal{D} + H) \left(\mathcal{D} + \frac{1}{3} \frac{E_6}{E_4}\right)f = 0 \tag{201}$$

is true for any meromorphic modular form H . For a generic choice of H , the above second-order MLDE will be characterized by an arbitrary complicated pole structure in the Wronskian. Note that the choice of H is sensitive to the data of the second independent solution of Eq. (201). Once we choose $H = -E_6/3E_4$, then Eq. (201) is reduced to the second-order MLDE with $\ell = 0$, namely Eq. (199). In conclusion, the unphysical solution of Eq. (199) can be considered as a remnant of lifting the first-order MLDE to the second-order MLDE without poles. For the solutions in the non-BPS type IV class, we conjecture that a pole structure in the first-order MLDE can be trivialized by lifting it to a higher-order MLDE.

Now let us describe the NS sector solutions of the non-BPS type IV in detail. To have non-negative integer coefficients in the vacuum solution, the central charges are restricted to the following 32 values:

$$c = 8, \frac{17}{2}, 9, \frac{19}{2}, 10, \dots, 23, \frac{47}{2}. \tag{202}$$

Among them, the eight solutions of $c = 17/2, 9, \dots, 12$ are presented in Ref. [54]. The explicit form of the solutions in q -series are summarized in Tables C9 and C10. The NS sector vacuum character can be expressed in terms of the NS partition function of a free Majorana–Weyl fermion ψ^{NS} as follows:

$$f_0^{\text{NS}}(\tau) = (\psi^{\text{NS}})^{2c} - 2c(\psi^{\text{NS}})^{2c-24}, \quad \text{for } c = 8, \frac{17}{2}, \dots, \frac{47}{2}. \tag{203}$$

Because ψ^{NS} is invariant under the Γ_θ , it is straightforward to see that $f_0^{\text{NS}}(\tau)$ is a weight-zero modular form of Γ_θ . Therefore $f_0^{\text{NS}}(\tau)$ can be interpreted as the left-moving NS sector partition function of single-character theories. This character does not have any free fermion as

$$f_0^{\text{NS}}(\tau) = q^{-\frac{c}{24}} \left[1 + c(47 - 2c)q + \frac{8c}{3}(100 - (c - 18)^2)q^{\frac{3}{2}} + \dots \right]. \tag{204}$$

The coefficients of f_0^{NS} being non-negative integers leads to the allowed values of the central charge of $8, 17/2, \dots, 47/2$. Note that for $c = 8$, the coefficient of q to half-integer power vanishes and so the theory is not fermionic. This theory is not a new one. One can show easily that f_0^{NS} for $c = 8$ is identical to the character $j^{1/3}$ of the $(\epsilon_8)_1$ WZW model. For $c = 12$, the character $f_0^{\text{NS}}(\tau)$ becomes the NS character $K(\tau)$ of the $c = 12$ Co₀ SCFT.

To explore the $\widetilde{\text{NS}}$ and R sector partition functions, we take modular transformation to ψ^{NS} . After all, the analytic structure of $\widetilde{\text{NS}}$ and R sector vacuum solutions are given by

$$\begin{aligned} f_0^{\widetilde{\text{NS}}}(\tau) &= (\psi^{\widetilde{\text{NS}}}(\tau))^{2c} - 2c(\psi^{\widetilde{\text{NS}}}(\tau))^{2c-24}, \\ f_0^{\text{R}}(\tau) &= (\psi^{\text{R}}(\tau))^{2c} + 2c(\psi^{\text{R}}(\tau))^{2c-24}. \end{aligned} \tag{205}$$

In the q -series expansion, f_0^{R} becomes

$$f_0^{\text{R}}(\tau) = q^{\frac{c}{12}-1} \left[2^{-11+c}c + 2^{-10+c}(1024 - 12c + c^2)q + 2^{-11+c}c(4372 - 47c + 2c^2)q^2 \dots \right]. \tag{206}$$

As recently discussed in Ref. [49], the R sector constraint could be stronger than that of the NS sector. To demonstrate this aspect, we present the q -expansion of $f_0^{\text{R}}(\tau)$ for $c = 19/2, c = 10$ and $c = 11$ as the illustrative examples:

$$\begin{aligned} f_0^{\text{R}}(\tau) &= \sqrt{2}q^{-\frac{5}{24}} \left(\frac{19}{8} + \frac{4001}{8}q + \frac{78014}{8}q^2 + \dots \right), \quad \text{for } c = \frac{19}{2}, \\ f_0^{\text{R}}(\tau) &= q^{-\frac{1}{6}} (5 + 1004q + 20510q^2 + \dots), \quad \text{for } c = 10, \\ f_0^{\text{R}}(\tau) &= q^{-\frac{1}{12}} (11 + 2026q + 45067q^2 + \dots), \quad \text{for } c = 11. \end{aligned} \tag{207}$$

For $c = 19/2$, the coefficients in q -series cannot be the integer values up to $\sqrt{2}$. For the same reason, we exclude the theories $c = 17/2, 19/2, 21/2, 23/2$. The R sector character for $c = 9$ is excluded as the coefficients are fractional. The only acceptable R sector solutions for $c < 12$ are the $c = 10, 11$ cases. Note that the unitarity bound $h \geq c/24$ is violated when $c < 12$, thus the solutions for $c = 10, 11$ cannot be considered as the vacuum character of an unitary supersymmetric RCFT. For $c \geq 12$, there is no constraint from the R sector. For all surviving theories with $c = 12, 12 + 1/2, 13, 13 + 1/2, \dots, 23, 23 + 1/2$, the coefficient of $q^{3/2}$ in Eq. (204) is positive and so these fermionic theories are expected to have a $\mathcal{N} = 1$ supersymmetric with the broken supersymmetric vacuum in the R sector. Thus we can assume $f_0^{\widetilde{\text{R}}} = 0$. In particular, the one with $c = 47/2$ is the fermionic CFT for the Baby Monster CFT [26].

We argue that the GSO projection of the characters (203) and (205) leads to a three-character bosonic CFT with $h = 0, 3/2, c/8 - 1$ for $c \geq 12$ with $\ell = 0$.³ Some of these solutions with $\ell = 0$ appeared in Ref. [14]. One can imagine their dual bosonic theories of central charge $24 - c$ and conformal weights $h = 0, 1/2, 3 - c/8$ were found to be an $SO(48 - 2c)_1$ WZW model whose fermionic version made of $48 - 2c$ free fermions has characters $(\psi^{\text{NS}})^{48-c}, (\psi^{\widetilde{\text{NS}}})^{48-c}$, and $(\psi^{\text{R}})^{48-c}$. The bilinear relation between the pair of these theories become

$$\frac{1}{2} \left[(\psi^{\text{NS}})^{48-2c} f_0^{\text{NS}} + (\psi^{\widetilde{\text{NS}}})^{48-2c} f_0^{\widetilde{\text{NS}}} + (\psi^{\text{R}})^{48-2c} f_0^{\text{R}}(\tau) \right] = J(\tau) + 48 \left(\frac{47}{2} - c \right). \tag{208}$$

³ To have unitary bosonic CFTs, the central charge should be larger than 8.

For $c = 23 + 1/2$, the above relation corresponds exactly to the fermionization of the $c = 24$ Monster CFT with $2A \mathbb{Z}_2$ symmetry in terms of the fermionic Baby Monster CFT and a single Majorana fermion [26].

Let us explore the bosonic theory a bit more. The three characters should be realized as the independent solutions of a third-order MLDE with $\ell = 0$, namely Eq. (194). With the parametrization

$$\alpha_0 = -\frac{c}{24}, \quad \alpha_1 = -\frac{c}{24} + \frac{3}{2}, \quad \alpha_2 = \frac{c}{12} - 1, \tag{209}$$

we find that the analytic structure of three independent solutions are given by

$$\begin{aligned} g_0(\lambda) &= \frac{1}{8} \left(\frac{\lambda(1-\lambda)}{16} \right)^{-\frac{c}{12}} (8 - c\lambda + c\lambda^2), \\ g_1(\lambda) &= \frac{1}{8} \left(\frac{\lambda(1-\lambda)}{16} \right)^{-\frac{c}{12}} (1-\lambda)^{\frac{c}{4}-2} (8 + (c-16)\lambda + 8\lambda^2), \\ g_2(\lambda) &= \frac{1}{8} \left(\frac{\lambda(1-\lambda)}{16} \right)^{-\frac{c}{12}} \lambda^{\frac{c}{4}-2} (c - c\lambda + 8\lambda^2), \end{aligned} \tag{210}$$

and they agree with the $f_0^{\text{NS}}(\tau)$, $f_0^{\widetilde{\text{NS}}}(\tau)$ and $f_0^{\text{R}}(\tau)$, respectively. Furthermore, the three characters of the bosonic CFT can be expressed as

$$f_0(\lambda) = \frac{1}{2}(g_0(\lambda) + g_1(\lambda)), \quad f_1(\lambda) = \frac{1}{2}(g_0(\lambda) - g_1(\lambda)), \quad f_2(\lambda) = g_2(\lambda). \tag{211}$$

For $c = 12$, the above three characters reproduce the characters of self-dual RCFT discussed in Ref. [16]. The modular transformation rule of $f_0(\lambda)$, $f_1(\lambda)$, $f_2(\lambda)$ for general central charge is given by

$$\begin{pmatrix} f_0(1-\lambda) \\ f_1(1-\lambda) \\ f_2(1-\lambda) \end{pmatrix} = \begin{pmatrix} \frac{1}{2} & \frac{1}{2} & \frac{1}{2} \\ \frac{1}{2} & \frac{1}{2} & -\frac{1}{2} \\ 1 & -1 & 0 \end{pmatrix} \begin{pmatrix} f_0(\lambda) \\ f_1(\lambda) \\ f_2(\lambda) \end{pmatrix}, \tag{212}$$

therefore the modular invariant partition function reads

$$Z(\tau, \bar{\tau}) = |f_0(\tau)|^2 + |f_1(\tau)|^2 + \frac{1}{2}|f_2(\tau)|^2. \tag{213}$$

Substituting Eq. (211) into Eq. (213), one can recast the partition function as

$$\begin{aligned} Z(\tau, \bar{\tau}) &= \frac{1}{2}f_0^{\text{NS}}(\tau)\bar{f}_0^{\text{NS}}(\bar{\tau}) + \frac{1}{2}f_0^{\widetilde{\text{NS}}}(\tau)\bar{f}_0^{\widetilde{\text{NS}}}(\bar{\tau}) + \frac{1}{2}f_0^{\text{R}}(\tau)\bar{f}_0^{\text{R}}(\bar{\tau}) \\ &= \frac{1}{2}Z_{\text{NS}} + \frac{1}{2}Z_{\widetilde{\text{NS}}} + \frac{1}{2}Z_{\text{R}}. \end{aligned} \tag{214}$$

In the second line, we use the fact that the partition functions of each spin structure can be factorized. Under the assumption of vanishing $Z_{\widetilde{\text{R}}}$, the GSO projection (214) of single-character fermionic theory leads to the three-character bosonic CFT with $h = 0, 3/2, (c/8) - 1$ only when $c \geq 12$.

Acknowledgements

We would like to thank Changrim Ahn, Gil Young Cho, Dongmin Gang, Hee-Cheol Kim and Sunil Mukhi for discussions. The work of J.B. is supported by the European Research Council (ERC) under the European Union’s Horizon 2020 research and innovation programme (Grant No. 787185). J.B. also acknowledge the hospitality of the Korea Institute for Advanced Study where this work was completed. Z.D., K.L., S.L., and M.S. are supported by KIAS Individual Grant PG076901, PG006904, PG056502, and PG064201. K.L. is also supported in part by National Research Foundation Individual Grant NRF-2017R1D1A1B06034369.

Funding

Open Access funding: SCOAP³.

Appendix A. $SL_2(\mathbb{Z})$ modular group and forms

In this appendix, we present the definitions and properties of various modular forms that appeared in the main text. In what follows, we denote τ as a point in the Poincaré upper half plane \mathbb{H} , and $q = \exp(2i\pi\tau)$.

Appendix A.1. The Eisenstein series

The Eisenstein series of weight $2k$, $k > 1$, is defined as

$$E_{2k}(\tau) = \sum_{(m,n) \in \mathbb{Z}^2 \setminus \{(0,0)\}} \frac{1}{(m + n\tau)^{2k}}, \tag{A.1}$$

and it satisfies the property

$$E_{2k}(\gamma\tau) = (c\tau + d)^{2k} E_{2k}(\tau), \quad \text{for } k \geq 2 \text{ and } \gamma \in SL_2(\mathbb{Z}), \tag{A.2}$$

In particular, the Eisenstein series of weight two, four and six are given by

$$\begin{aligned} E_2(\tau) &= 1 - 24 \sum_{n=1}^{\infty} \frac{nq^n}{1 - q^n} = 1 - 24q - 72q^2 - 96q^3 - 168q^4 - 144q^5 + \dots, \\ E_4(\tau) &= 1 + 240 \sum_{n=1}^{\infty} \frac{n^3q^n}{1 - q^n} = 1 + 240q + 2160q^2 + 6720q^3 + 17520q^4 + \dots, \\ E_6(\tau) &= 1 - 504 \sum_{n=1}^{\infty} \frac{n^5q^n}{1 - q^n} = 1 - 504q - 16632q^2 - 122976q^3 - 532728q^4 + \dots. \end{aligned} \tag{A.3}$$

The Eisenstein series $E_4(\tau)$ and $E_6(\tau)$ are modular forms of weight four and six, respectively. On the other hand, the modular transformation rule of the weight two Eisenstein series is given by

$$E_2(\gamma\tau) = (c\tau + d)^2 E_2(\tau) + \frac{\pi i}{6} c(c\tau + d), \tag{A.4}$$

thus it is referred to as the quasi-modular form. It enters in the definition of the Ramanujan–Serre covariant derivative to be defined below.

Appendix A.2. The Dedekind eta function

The Dedekind eta function is a modular form of weight 1/2 and defined by the infinite product

$$\eta(\tau) = q^{\frac{1}{24}} \prod_{n=1}^{\infty} (1 - q^n). \tag{A.5}$$

Under T and S , the η function transforms as

$$\eta(\tau + 1) = e^{\frac{\pi i}{12}} \eta(\tau), \quad \eta(-1/\tau) = \sqrt{-i\tau} \eta(\tau). \tag{A.6}$$

Appendix A.3. The Jacobi theta functions

The theta functions with vanishing elliptic argument are given by the following infinite products:

$$\begin{aligned} \vartheta_2(\tau) &= \theta_2(\tau, 0) = 2q^{\frac{1}{8}} \prod_{n=1}^{\infty} (1 - q^n)(1 + q^n)^2 = 2q^{\frac{1}{8}} + 2q^{\frac{9}{8}} + 2q^{\frac{25}{8}} + 2q^{\frac{49}{8}} + \dots, \\ \vartheta_3(\tau) &= \theta_3(\tau, 0) = \prod_{n=1}^{\infty} (1 - q^n)(1 + q^{n-\frac{1}{2}})^2 = 1 + 2q^{\frac{1}{2}} + 2q^2 + 2q^{\frac{9}{2}} + 2q^8 + \dots, \\ \vartheta_4(\tau) &= \theta_4(\tau, 0) = \prod_{n=1}^{\infty} (1 - q^n)(1 - q^{n-\frac{1}{2}})^2 = 1 - 2q^{\frac{1}{2}} + 2q^2 - 2q^{\frac{9}{2}} + 2q^8 + \dots. \end{aligned} \tag{A.7}$$

Under S and T transformations, the theta functions transform as

$$\begin{aligned} \vartheta_2(\tau + 1) &= \sqrt{i} \vartheta_2(\tau), \quad \vartheta_3(\tau + 1) = \vartheta_4(\tau), \quad \vartheta_4(\tau + 1) = \vartheta_3(\tau), \\ \vartheta_2(-1/\tau) &= \sqrt{-i\tau} \vartheta_4(\tau), \quad \vartheta_3(-1/\tau) = \sqrt{-i\tau} \vartheta_3(\tau), \quad \vartheta_4(-1/\tau) = \sqrt{-i\tau} \vartheta_2(\tau). \end{aligned} \tag{A.8}$$

Appendix A.4. Useful identities

We summarize some useful identities satisfied by the modular forms defined above as follows:

$$\begin{aligned} \vartheta_3^4(\tau) &= \vartheta_2^4(\tau) + \vartheta_4^4(\tau), \quad \eta^3(\tau) = \frac{1}{2} \vartheta_2(\tau) \vartheta_3(\tau) \vartheta_4(\tau), \\ E_4(\tau) &= \frac{1}{2} (\vartheta_2^8 + \vartheta_3^8 + \vartheta_4^8), \quad E_6(\tau) = \frac{1}{2} (\vartheta_2^4 + \vartheta_3^4)(\vartheta_3^4 + \vartheta_4^4)(\vartheta_4^4 - \vartheta_2^4). \end{aligned} \tag{A.9}$$

The derivative of eta function with respect to τ is given by

$$\frac{1}{2\pi i} \frac{d}{d\tau} \eta(\tau) = \frac{1}{24} E_2(\tau) \eta(\tau). \tag{A.10}$$

The Ramanujan–Serre covariant derivative is then defined as

$$\mathcal{D}_k = \frac{1}{2\pi i} \frac{d}{d\tau} - \frac{k}{12} E_2(\tau), \tag{A.11}$$

and it sends a weight k modular form to a modular form of weight $k + 2$. By Eq. (A.10), one can see that the covariant derivative of the eta function vanishes. The Eisenstein series E_2, E_4, E_6 satisfies the Ramanujan identities

$$\mathcal{D}_2 E_2 = -\frac{1}{12} E_4, \quad \mathcal{D}_4 E_4 = -\frac{1}{3} E_6, \quad \mathcal{D}_6 E_6 = -\frac{1}{2} E_4^2. \tag{A.12}$$

The Klein j -invariant is the unique holomorphic modular function on \mathbb{H} with a simple pole at $\tau = i\infty$. It can be expressed in terms of the Eisenstein series as

$$j(\tau) = \frac{E_4(\tau)^3}{\eta(\tau)^{24}} = \frac{1728E_4(\tau)^3}{E_4(\tau)^3 - E_6(\tau)^2} = q^{-1} + 744 + 196884q + 21493760q^2 + 864299970q^3 + 20245856256q^4 + \dots \quad (\text{A.13})$$

Appendix B. Modular matrix of the fermionic second-order MLDE

In this appendix, we provide a closed-form expression for the NS sector solutions of the second-order MLDE (83) and their S -matrix. Since the differential equation for $f^{\text{NS}}(\lambda)$,

$$\left[\frac{d^2}{d\lambda^2} + \frac{2(1 + 3\mu_1)(1 - 2\lambda)}{3\lambda(1 - \lambda)} \frac{d}{d\lambda} + \frac{4(\mu_2 + \mu_3) - 4\mu_3\lambda(1 - \lambda)}{\lambda^2(1 - \lambda)^2} \right] f^{\text{NS}}(\lambda) = 0, \quad (\text{B.1})$$

takes the form of Riemann’s differential equation, the solutions of Eq. (B.1) can be written in terms of Riemann’s P -symbol [42]

$$f^{\text{NS}}(\lambda) = P \left\{ \begin{matrix} 0 & 1 & \infty \\ -\frac{c}{12} & -\frac{c}{12} & \alpha^+ \\ 2h^{\text{NS}} - \frac{c}{12} & 2h^{\text{NS}} - \frac{c}{12} & \alpha^- \end{matrix} \middle| \lambda \right\}, \quad (\text{B.2})$$

where

$$\alpha^\pm = \frac{1}{12} \left(6 + 2c - 24h^{\text{NS}} \pm \sqrt{4 - a_1 + 2c - 32h^{\text{NS}} + 2a_1h^{\text{NS}} - 4ch^{\text{NS}} + 64(h^{\text{NS}})^2} \right). \quad (\text{B.3})$$

To cast the above solution into a form involving the hypergeometric function ${}_2F_1$, we use the following identity satisfied by Riemann’s P -symbol:

$$\lambda^\sigma (1 - \lambda)^\rho P \left\{ \begin{matrix} 0 & 1 & \infty \\ \alpha_1 & \beta_1 & \gamma_1 \\ \alpha_2 & \beta_2 & \gamma_2 \end{matrix} \middle| \lambda \right\} = P \left\{ \begin{matrix} 0 & 1 & \infty \\ \alpha_1 + \sigma & \beta_1 + \rho & \gamma_1 - \sigma - \rho \\ \alpha_2 + \sigma & \beta_2 + \rho & \gamma_2 - \sigma - \rho \end{matrix} \middle| \lambda \right\}. \quad (\text{B.4})$$

After redefining the NS sector character by

$$f^{\text{NS}}(\lambda) = \lambda^{-\frac{c}{12}} (1 - \lambda)^{-\frac{c}{12}} \tilde{f}^{\text{NS}}(\lambda), \quad (\text{B.5})$$

and using the identity (B.4), one can find

$$\tilde{f}^{\text{NS}}(\lambda) = P \left\{ \begin{matrix} 0 & 1 & \infty \\ 0 & 0 & \beta^+ \\ 2h^{\text{NS}} & 2h^{\text{NS}} & \beta^- \end{matrix} \middle| \lambda \right\}, \quad (\text{B.6})$$

where $\beta^\pm = \alpha^\pm - c/6$. It is known that Riemann's P -symbol of the form (B.6) solves the ordinary hypergeometric differential equation. Therefore, we obtain the closed-form expression of NS sector characters in terms of the hypergeometric function:

$$\begin{aligned} f_0^{\text{NS}}(\lambda) &= 2^{\frac{c}{3}} \lambda^{-\frac{c}{12}} (1-\lambda)^{-\frac{c}{12}} {}_2F_1(\beta^+, \beta^-; 1-2h^{\text{NS}}; \lambda) \\ f_1^{\text{NS}}(\lambda) &= b_0 2^{\frac{c}{3}-8h^{\text{NS}}} \lambda^{2h^{\text{NS}}-\frac{c}{12}} (1-\lambda)^{-\frac{c}{12}} {}_2F_1(\beta^+ + 2h^{\text{NS}}, \beta^- + 2h^{\text{NS}}; 1+2h^{\text{NS}}; \lambda). \end{aligned} \tag{B.7}$$

Here b_0 is an overall normalization constant.⁴

The modular matrix of vector-valued modular form $(f_0^{\text{NS}}(\lambda), f_1^{\text{NS}}(\lambda))$ can be found via the Gauss identity of the hypergeometric function

$$\begin{aligned} {}_2F_1(\alpha_1, \alpha_2; \alpha_3; 1-\lambda) &= \frac{\Gamma(\alpha_3)\Gamma(\alpha_3-\alpha_1-\alpha_2)}{\Gamma(\alpha_3-\alpha_1)\Gamma(\alpha_3-\alpha_2)} {}_2F_1(\alpha_1, \alpha_2; \alpha_1+\alpha_2-\alpha_3+1; \lambda) \\ &+ \frac{\Gamma(\alpha_3)\Gamma(\alpha_1+\alpha_2-\alpha_3)}{\Gamma(\alpha_1)\Gamma(\alpha_2)} \lambda^{\alpha_3-\alpha_1-\alpha_2} {}_2F_1(\alpha_3-\alpha_1, \alpha_3-\alpha_2; \alpha_3-\alpha_1-\alpha_2+1; \lambda), \end{aligned} \tag{B.8}$$

and Euler transformation formula of hypergeometric function

$${}_2F_1(\alpha, \beta; \gamma; \lambda) = (1-\lambda)^{\gamma-\alpha-\beta} {}_2F_1(\gamma-\alpha, \gamma-\beta; \gamma; \lambda). \tag{B.9}$$

After some algebra, one can read the transformation rule of NS sector characters:

$$\begin{pmatrix} f_0^{\text{NS}}(1-\lambda) \\ f_1^{\text{NS}}(1-\lambda) \end{pmatrix} = \begin{pmatrix} \frac{\Gamma(1-2h^{\text{NS}})\Gamma(2h^{\text{NS}})}{\Gamma(1-2h^{\text{NS}}-\beta^+)\Gamma(1-2h^{\text{NS}}-\beta^-)} & \frac{2^{8h^{\text{NS}}}}{b_0} \frac{\Gamma(1-2h^{\text{NS}})\Gamma(-2h^{\text{NS}})}{\Gamma(\beta^+)\Gamma(\beta^-)} \\ \frac{b_0}{2^{8h^{\text{NS}}}} \frac{\Gamma(1+2h^{\text{NS}})\Gamma(2h^{\text{NS}})}{\Gamma(1-\beta^+)\Gamma(1-\beta^-)} & \frac{\Gamma(1+2h^{\text{NS}})\Gamma(-2h^{\text{NS}})}{\Gamma(\beta^++2h^{\text{NS}})\Gamma(\beta^-+2h^{\text{NS}})} \end{pmatrix} \begin{pmatrix} f_0^{\text{NS}}(\lambda) \\ f_1^{\text{NS}}(\lambda) \end{pmatrix}$$

Appendix C. Solutions of the fermionic second-order MLDE in q -series

In this appendix, we enlist the q -series for the NS and R characters for types of solutions of the second order MLDE in section 5.

⁴ We fix the overall factor $2^{c/3}$ in the vacuum character by $\chi_0^{\text{NS}}(\lambda) = q^{-c/24} + \dots$.

Table C1. NS sector solutions of BPS type I.

c	h^{NS}	(μ_1, μ_2, μ_3)	NS sector character
1	0	$(\frac{1}{12}, -\frac{1}{192}, 0)$	$q^{-\frac{1}{24}} (1 + q + 2q^{3/2} + 2q^2 + 2q^{5/2} + 3q^3 + \dots)$
	$\frac{1}{6}$		$q^{\frac{1}{8}} (1 + q^{1/2} + q + q^{3/2} + 2q^2 + 3q^{5/2} + 3q^3 + \dots)$
$\frac{9}{4}$	0	$(\frac{5}{48}, -\frac{15}{1024}, 0)$	$q^{-\frac{3}{32}} (1 + 3q + 7q^{3/2} + 9q^2 + 12q^{5/2} + 22q^3 + \dots)$
	$\frac{1}{4}$		$q^{\frac{5}{32}} (3 + 5q^{1/2} + 9q + 15q^{3/2} + 27q^2 + 45q^{5/2} + \dots)$
6	0	$(\frac{1}{6}, -\frac{1}{16}, 0)$	$q^{-\frac{1}{4}} (1 + 18q + 64q^{3/2} + 159q^2 + 384q^{5/2} + \dots)$
	$\frac{1}{2}$		$q^{\frac{1}{4}} (4 + 16q^{1/2} + 56q + 160q^{3/2} + 404q^2 + 944q^{5/2} + \dots)$
$\frac{39}{4}$	0	$(\frac{11}{48}, -\frac{143}{1024}, 0)$	$q^{-\frac{13}{32}} (1 + 78q + 429q^{3/2} + 1794q^2 + 6435q^{5/2} + \dots)$
	$\frac{3}{4}$		$q^{\frac{11}{32}} (65 + 429q^{1/2} + 2145q + 8437q^{3/2} + 28236q^2 + \dots)$
11	0	$(\frac{1}{4}, -\frac{11}{64}, 0)$	$q^{-\frac{11}{24}} (1 + 143q + 924q^{3/2} + 4499q^2 + 18084q^{5/2} + \dots)$
	$\frac{5}{6}$		$q^{\frac{3}{8}} (66 + 495q^{1/2} + 2718q + 11649q^{3/2} + 42174q^2 + \dots)$

Table C2. R sector solutions of BPS type I.

c	h^{R}	(μ_1, μ_2, μ_3)	R sector character
1	$\frac{1}{24}$	$(\frac{1}{12}, -\frac{1}{192}, 0)$	$\sqrt{2} (1 + 2q + 4q^2 + 6q^3 + 10q^4 + 16q^5 + 24q^6 + \dots)$
	$\frac{3}{8}$		$q^{\frac{1}{3}} (2 + 2q + 4q^2 + 8q^3 + 12q^4 + 18q^5 + 28q^6 + \dots)$
$\frac{9}{4}$	$\frac{3}{32}$	$(\frac{5}{48}, -\frac{15}{1024}, 0)$	$2 + 12q + 36q^2 + 88q^3 + 204q^4 + 432q^5 + 856q^6 + \dots$
	$\frac{15}{32}$		$\sqrt{2} q^{\frac{3}{8}} (4 + 12q + 36q^2 + 88q^3 + 192q^4 + 396q^5 + 776q^6 + \dots)$
6	$\frac{1}{4}$	$(\frac{1}{6}, -\frac{1}{16}, 0)$	$2 + 64q + 512q^2 + 2816q^3 + 12288q^4 + 45952q^5 + \dots$
	$\frac{3}{4}$		$q^{\frac{1}{2}} (8 + 96q + 624q^2 + 3008q^3 + 12072q^4 + 42528q^5 + \dots)$
$\frac{39}{4}$	$\frac{13}{32}$	$(\frac{11}{48}, -\frac{143}{1024}, 0)$	$12 + 1144q + 19032q^2 + 180336q^3 + 1247688q^4 + \dots$
	$\frac{33}{32}$		$\sqrt{2} q^{\frac{5}{8}} (208 + 5136q + 57408q^2 + 439504q^3 + 2647632q^4 + \dots)$
11	$\frac{11}{24}$	$(\frac{1}{4}, -\frac{11}{64}, 0)$	$\sqrt{2} (12 + 1584q + 32472q^2 + 360096q^3 + 2846448q^4 + \dots)$
	$\frac{9}{8}$		$q^{\frac{2}{3}} (440 + 13024q + 169048q^2 + 1470944q^3 + 9929392q^4 + \dots)$

Table C3. NS sector solutions of BPS type II.

c	h^{ns}	(μ_1, μ_2, μ_3)	NS sector characters
$\frac{3}{4}$	0 $\frac{1}{4}$	$(-\frac{1}{48}, -\frac{7}{1024}, 0)$	$q^{-\frac{1}{32}} (1 + q^{\frac{1}{2}} + q + q^{\frac{3}{2}} + 2q^2 + 2q^{\frac{5}{2}} + 2q^3 + 3q^{\frac{7}{2}} + \dots)$ $q^{\frac{7}{32}} (1 + q^{\frac{3}{2}} + q^2 + q^{\frac{5}{2}} + q^3 + q^{\frac{7}{2}} + 2q^4 + 2q^{\frac{9}{2}} \dots)$
$\frac{3}{2}$	0 $\frac{1}{4}$	$(\frac{1}{24}, -\frac{3}{256}, 0)$	$q^{-\frac{1}{16}} (1 + q^{\frac{1}{2}} + 3q + 4q^{\frac{3}{2}} + 5q^2 + 8q^{\frac{5}{2}} + 11q^3 + \dots)$ $q^{\frac{3}{16}} (2 + 2q^{\frac{1}{2}} + 2q + 4q^{\frac{3}{2}} + 8q^2 + 10q^{\frac{5}{2}} + 12q^3 + \dots)$
3	0 $\frac{1}{3}$	$(\frac{1}{12}, -\frac{5}{192}, 0)$	$q^{-\frac{1}{8}} (1 + 2q^{\frac{1}{2}} + 9q + 18q^{\frac{3}{2}} + 29q^2 + 54q^{\frac{5}{2}} + 100q^3 + \dots)$ $q^{\frac{5}{24}} (3 + 6q^{\frac{1}{2}} + 12q + 24q^{\frac{3}{2}} + 48q^2 + 84q^{\frac{5}{2}} + 135q^3 + \dots)$
6	0 $\frac{1}{2}$	$(\frac{1}{6}, -\frac{1}{16}, 0)$	$q^{-\frac{1}{4}} (1 + 4q^{\frac{1}{2}} + 34q + 120q^{\frac{3}{2}} + 319q^2 + 788q^{\frac{5}{2}} + \dots)$ $q^{\frac{1}{4}} (8 + 32q^{\frac{1}{2}} + 112q + 320q^{\frac{3}{2}} + 808q^2 + 1888q^{\frac{5}{2}} + \dots)$
9	0 $\frac{2}{3}$	$(\frac{1}{4}, -\frac{7}{64}, 0)$	$q^{-\frac{3}{8}} (1 + 6q^{\frac{1}{2}} + 93q + 494q^{\frac{3}{2}} + 1950q^2 + 6504q^{\frac{5}{2}} + \dots)$ $q^{\frac{7}{24}} (27 + 162q^{\frac{1}{2}} + 783q + 2970q^{\frac{3}{2}} + 9531q^2 + \dots)$
$\frac{21}{2}$	0 $\frac{3}{4}$	$(\frac{7}{24}, -\frac{35}{256}, 0)$	$q^{-\frac{7}{16}} (1 + 7q^{\frac{1}{2}} + 154q + 973q^{\frac{3}{2}} + 4550q^2 + 17472q^{\frac{5}{2}} + \dots)$ $q^{\frac{5}{16}} (56 + 392q^{\frac{1}{2}} + 2144q + 9128q^{\frac{3}{2}} + 32536q^2 + \dots)$
$\frac{45}{4}$	0 $\frac{3}{4}$	$(\frac{17}{48}, -\frac{135}{1024}, 0)$	$q^{-\frac{15}{32}} (1 + 15q^{\frac{1}{2}} + 225q + 1555q^{\frac{3}{2}} + 7920q^2 + \dots)$ $q^{\frac{9}{32}} (35 + 252q^{\frac{1}{2}} + 1485q + 6805q^{\frac{3}{2}} + 25845q^2 + \dots)$

Table C4. R sector solutions of BPS type II.

c	h^r	(μ_1, μ_2, μ_3)	R sector characters
$\frac{3}{4}$	$\frac{1}{32}$ $\frac{5}{32}$	$(-\frac{1}{48}, -\frac{7}{1024}, 0)$	$1 + 2q + 2q^2 + 4q^3 + 6q^4 + 8q^5 + 12q^6 + 16q^7 + \dots$ $\sqrt{2}q^{\frac{1}{8}} (1 + q + 2q^2 + 3q^3 + 4q^4 + 6q^5 + 9q^6 + 12q^7 + \dots)$
$\frac{3}{2}$	$\frac{1}{16}$ $\frac{5}{16}$	$(\frac{1}{24}, -\frac{3}{256}, 0)$	$\sqrt{2} (1 + 4q + 8q^2 + 16q^3 + 32q^4 + 56q^5 + 96q^6 + \dots)$ $\sqrt{2}q^{\frac{1}{4}} (2 + 4q + 10q^2 + 20q^3 + 36q^4 + 64q^5 + 110q^6 + \dots)$
3	$\frac{1}{8}$ $\frac{11}{24}$	$(\frac{1}{12}, -\frac{5}{192}, 0)$	$2 + 20q + 72q^2 + 220q^3 + 596q^4 + 1440q^5 + \dots$ $\sqrt{2}q^{\frac{1}{3}} (6 + 30q + 108q^2 + 312q^3 + 804q^4 + 1902q^5 + \dots)$
6	0 $\frac{1}{2}$	$(\frac{1}{6}, -\frac{1}{16}, 0)$	$2 + 64q + 512q^2 + 2816q^3 + 12288q^4 + 45952q^5 + \dots$ $q^{\frac{1}{2}} (32 + 384q + 2496q^2 + 12032q^3 + 48288q^4 + \dots)$
9	$\frac{3}{8}$ $\frac{25}{24}$	$(\frac{1}{4}, -\frac{7}{64}, 0)$	$8 + 672q + 9744q^2 + 83648q^3 + 532128q^4 + \dots$ $\sqrt{2}q^{\frac{2}{3}} (216 + 4320q + 42552q^2 + 294624q^3 + \dots)$
$\frac{21}{2}$	$\frac{7}{16}$ $\frac{19}{16}$	$(\frac{7}{24}, -\frac{35}{256}, 0)$	$\sqrt{2} (8 + 1120q + 21056q^2 + 219520q^3 + \dots)$ $\sqrt{2}q^{\frac{3}{4}} (448 + 10880q + 126784q^2 + 1018752q^3 + \dots)$
$\frac{45}{4}$	$\frac{15}{32}$ $\frac{43}{32}$	$(\frac{17}{48}, -\frac{135}{1024}, 0)$	$8 + 2160q + 45840q^2 + 524000q^3 + 4250160q^4 + \dots$ $\sqrt{2}q^{\frac{7}{8}} (960 + 23104q + 279360q^2 + 2346240q^3 + \dots)$

Table C5. NS sector solutions of non-BPS type I. The solutions with an asterisk ($c = 102/5, 85/4, 22$) do not have a consistent fusion rule algebra.

c	h^{NS}	(μ_1, μ_2, μ_3)	NS sector character
$\frac{7}{10}$	0 $\frac{1}{10}$	$(\frac{1}{8}, -\frac{7}{1280}, \frac{49}{14400})$	$q^{-\frac{7}{240}} (1 + q^{3/2} + q^2 + q^{5/2} + q^3 + 2q^{7/2} + \dots)$ $q^{\frac{17}{240}} (1 + q^{1/2} + q + q^{3/2} + q^2 + 2q^{5/2} + 2q^3 + \dots)$
$\frac{133}{10}$	0 $\frac{9}{10}$	$(\frac{3}{8}, -\frac{399}{1280}, \frac{1729}{14400})$	$q^{-\frac{133}{240}} (1 + 133q + 1463q^{3/2} + 9044q^2 + \dots)$ $q^{\frac{83}{240}} (133 + 1539q^{1/2} + 10318q + 52535q^{3/2} + \dots)$
$\frac{91}{5}$	0 $\frac{11}{10}$	$(\frac{7}{12}, -\frac{637}{960}, \frac{91}{225})$	$q^{-\frac{91}{120}} (1 + 91q + 2548q^{3/2} + 28301q^2 + \dots)$ $q^{\frac{41}{120}} (364 + 7007q^{1/2} + 69732q + 487109q^{3/2} + \dots)$
$\frac{39}{2}$	0 $\frac{7}{6}$	$(\frac{5}{8}, -\frac{195}{256}, \frac{91}{192})$	$q^{-\frac{13}{16}} (1 + 78q + 2925q^{3/2} + 37908q^2 + \dots)$ $q^{\frac{17}{48}} (351 + 7371q^{1/2} + 79353q + 594243q^{3/2} + \dots)$
$\frac{102}{5}^*$	0 $\frac{6}{5}$	$(\frac{2}{3}, -\frac{17}{20}, \frac{221}{400})$	$q^{-\frac{17}{20}} (1 + 102q + 4352q^{3/2} + 62577q^2 + \dots)$ $q^{\frac{7}{20}} (374 + 8448q^{1/2} + 96900q + 765952q^{3/2} + \dots)$
21	0 $\frac{5}{4}$	$(\frac{2}{3}, -\frac{7}{8}, \frac{35}{64})$	$q^{-\frac{7}{8}} (1 + 63q + 3584q^{3/2} + 55734q^2 + \dots)$ $q^{\frac{3}{8}} (672 + 15360q^{1/2} + 178976q + 1440768q^{3/2} + \dots)$
$\frac{85}{4}^*$	0 $\frac{5}{4}$	$(\frac{11}{16}, -\frac{935}{1024}, \frac{85}{144})$	$q^{-\frac{85}{96}} (1 + 85q + 4675q^{3/2} + 74630q^2 + \dots)$ $q^{\frac{35}{96}} (357 + 8415q^{1/2} + 100555q + 825945q^{3/2} + \dots)$
22*	0 $\frac{4}{3}$	$(\frac{2}{3}, -\frac{11}{12}, \frac{77}{144})$	$q^{-\frac{11}{12}} (1 + 22q + 2816q^{3/2} + 50171q^2 + \dots)$ $q^{\frac{5}{12}} (891 + 20736q^{1/2} + 247698q + 2052864q^{3/2} + \dots)$
$\frac{114}{5}$	0 $\frac{7}{5}$	$(\frac{2}{3}, -\frac{19}{20}, \frac{209}{400})$	$q^{-\frac{19}{20}} (1 + 2432q^{3/2} + 48621q^2 + \dots)$ $q^{\frac{9}{20}} (1938 + 45696q^{1/2} + 556206q + 4713216q^{3/2} + \dots)$

Table C6. R sector solutions of non-BPS type I.

c	h^R	(μ_1, μ_2, μ_3)	R sector character
$\frac{7}{10}$	$\frac{3}{80}$ $\frac{7}{16}$	$(\frac{1}{8}, -\frac{7}{1280}, \frac{49}{14400})$	$\sqrt{2}q^{\frac{1}{120}} (1 + q + 2q^2 + 3q^3 + 4q^4 + 6q^5 + \dots)$ $\sqrt{2}q^{\frac{49}{120}} (1 + q + q^2 + 2q^3 + 3q^4 + 4q^5 + \dots)$
$\frac{133}{10}$	$\frac{57}{80}$ $\frac{21}{16}$	$(\frac{3}{8}, -\frac{399}{1280}, \frac{1729}{14400})$	$\sqrt{2}q^{\frac{19}{120}} (56 + 7448q + 186352q^2 + 2512104q^3 + \dots)$ $\sqrt{2}q^{\frac{91}{120}} (912 + 35112q + 577752q^2 + 6183968q^3 + \dots)$
$\frac{91}{5}$	$\frac{49}{40}$ $\frac{13}{8}$	$(\frac{7}{12}, -\frac{637}{960}, \frac{91}{225})$	$q^{\frac{7}{15}} (1664 + 232960q + 8118656q^2 + 153033216q^3 + \dots)$ $q^{\frac{13}{15}} (9856 + 658944q + 17169152q^2 + 273681408q^3 + \dots)$
$\frac{39}{2}$	$\frac{65}{48}$ $\frac{27}{16}$	$(\frac{5}{8}, -\frac{195}{256}, \frac{91}{192})$	$q^{\frac{13}{24}} (3456 + 494208q + 18555264q^2 + 377574912q^3 + \dots)$ $q^{\frac{7}{8}} (11648 + 908544q + 26687232q^2 + 470863744q^3 + \dots)$
$\frac{102}{5}^*$	$\frac{3}{2}$ $\frac{17}{10}$	$(\frac{2}{3}, -\frac{17}{20}, \frac{221}{400})$	$q^{\frac{13}{20}} (8704 + 1122816q + 42275328q^2 + 881340928q^3 + \dots)$ $q^{\frac{17}{20}} (16896 + 1531904q + 49795584q^2 + 952435200q^3 + \dots)$
21	$\frac{3}{2}$ $\frac{7}{4}$	$(\frac{2}{3}, -\frac{7}{8}, \frac{35}{64})$	$q^{\frac{5}{8}} (7168 + 1053696q + 42897408q^2 + 948921344q^3 + \dots)$ $q^{\frac{7}{8}} (30720 + 2881536q + 97298432q^2 + 1928994816q^3 + \dots)$
$\frac{85}{4}^*$	$\frac{51}{32}$ $\frac{55}{32}$	$(\frac{11}{16}, -\frac{935}{1024}, \frac{85}{144})$	$q^{\frac{17}{24}} (8960 + 1153280q + 45012736q^2 + 977589760q^3 + \dots)$ $q^{\frac{5}{6}} (26112 + 2698240q + 95979520q^2 + 1973719040q^3 + \dots)$
22*	$\frac{3}{2}$ $\frac{11}{6}$	$(\frac{2}{3}, -\frac{11}{12}, \frac{77}{144})$	$q^{\frac{7}{12}} (5632 + 1036288q + 48080384q^2 + 1173607424q^3 + \dots)$ $q^{\frac{11}{12}} (41472 + 4105728q + 147350016q^2 + 3095262720q^3 + \dots)$
$\frac{114}{5}$	$\frac{3}{2}$ $\frac{19}{10}$	$(\frac{2}{3}, -\frac{19}{20}, \frac{209}{400})$	$q^{\frac{11}{20}} (4864 + 1079808q + 55653888q^2 + 1469453312q^3 + \dots)$ $q^{\frac{19}{20}} (91392 + 9426432q + 354483456q^2 + 7786145280q^3 + \dots)$

Table C7. NS sector characters of non-BPS type II.

c	h^{NS}	(μ_1, μ_2, μ_3)	NS sector character
$\frac{9}{2}$	0	$(\frac{1}{24}, -\frac{3}{256}, -\frac{3}{64})$	$q^{-\frac{3}{16}} (1 + 27q + 21q^{3/2} + 126q^2 + 126q^{5/2} + \dots)$
	$\frac{1}{2}$		$q^{\frac{5}{16}} (1 + q^{1/2} + 8q + 9q^{3/2} + 37q^2 + 45q^{5/2} + \dots)$
5	0	$(\frac{1}{12}, -\frac{5}{192}, -\frac{5}{144})$	$q^{-\frac{5}{24}} (1 + 25q + 40q^{3/2} + 130q^2 + 232q^{5/2} + \dots)$
	$\frac{1}{2}$		$q^{\frac{7}{24}} (2 + 4q^{1/2} + 18q + 36q^{3/2} + 96q^2 + 184q^{5/2} + \dots)$
$\frac{11}{2}$	0	$(\frac{1}{8}, -\frac{11}{256}, -\frac{11}{576})$	$q^{-\frac{11}{48}} (1 + 22q + 55q^{3/2} + 143q^2 + 319q^{5/2} + \dots)$
	$\frac{1}{2}$		$q^{\frac{13}{48}} (1 + 3q^{1/2} + 11q + 28q^{3/2} + 69q^2 + \dots)$
$\frac{13}{2}$	0	$(\frac{5}{24}, -\frac{65}{768}, \frac{13}{576})$	$q^{-\frac{13}{48}} (1 + 13q + 65q^{3/2} + 169q^2 + 416q^{5/2} + \dots)$
	$\frac{1}{2}$		$q^{\frac{11}{48}} (1 + 5q^{1/2} + 18q + 55q^{3/2} + 146q^2 + \dots)$
7	0	$(\frac{1}{4}, -\frac{7}{64}, \frac{7}{144})$	$q^{-\frac{7}{24}} (1 + 7q + 56q^{3/2} + 161q^2 + 392q^{5/2} + \dots)$
	$\frac{1}{2}$		$q^{\frac{5}{24}} (6 + 36q^{1/2} + 138q + 444q^{3/2} + 1242q^2 + \dots)$
$\frac{15}{2}$	0	$(\frac{287}{1560}, -\frac{287}{3328}, -\frac{5}{832})$	$q^{-\frac{5}{16}} (1 + 35q^{3/2} + 120q^2 + 273q^{5/2} + \dots)$
	$\frac{1}{2}$		$q^{\frac{3}{16}} (1 + 7q^{1/2} + 29q + 98q^{3/2} + 288q^2 + \dots)$

Table C8. R sector characters of non-BPS type II.

c	h^R	(μ_1, μ_2, μ_3)	R sector character
$\frac{9}{2}$	$\frac{1}{16}$	$(\frac{1}{24}, -\frac{3}{256}, -\frac{3}{64})$	$q^{-\frac{1}{8}} (1 + 29q + 163q^2 + 732q^3 + 2569q^4 + \dots)$
	$\frac{9}{16}$		$q^{\frac{3}{8}} (1 + 9q + 45q^2 + 174q^3 + 576q^4 + \dots)$
5	$\frac{1}{8}$	$(\frac{1}{12}, -\frac{5}{192}, -\frac{5}{144})$	$q^{-\frac{1}{12}} (1 + 30q + 193q^2 + 926q^3 + 3524q^4 + \dots)$
	$\frac{5}{8}$		$q^{\frac{5}{12}} (8 + 80q + 440q^2 + 1840q^3 + 6520q^4 + \dots)$
$\frac{11}{2}$	$\frac{3}{16}$	$(\frac{1}{8}, -\frac{11}{256}, -\frac{11}{576})$	$q^{-\frac{1}{24}} (1 + 31q + 224q^2 + 1151q^3 + 4705q^4 + \dots)$
	$\frac{11}{16}$		$q^{\frac{11}{24}} (8 + 88q + 528q^2 + 2376q^3 + 8976q^4 + \dots)$
$\frac{13}{2}$	$\frac{5}{16}$	$(\frac{5}{24}, -\frac{65}{768}, \frac{13}{576})$	$q^{\frac{1}{24}} (2 + 66q + 578q^2 + 3396q^3 + 15748q^4 + \dots)$
	$\frac{13}{16}$		$q^{\frac{13}{24}} (16 + 208q + 1456q^2 + 7488q^3 + 31824q^4 + \dots)$
7	$\frac{3}{8}$	$(\frac{1}{4}, -\frac{7}{64}, \frac{7}{144})$	$q^{\frac{1}{12}} (4 + 136q + 1292q^2 + 8088q^3 + 39716q^4 + \dots)$
	$\frac{7}{8}$		$q^{\frac{7}{12}} (96 + 1344q + 10080q^2 + 55104q^3 + 247296q^4 + \dots)$
$\frac{15}{2}$	$\frac{7}{16}$	$(\frac{287}{1560}, -\frac{287}{3328}, -\frac{5}{832})$	$q^{\frac{1}{8}} (4 + 140q + 1432q^2 + 9524q^3 + 49376q^4 + \dots)$
	$\frac{15}{16}$		$q^{\frac{5}{8}} (32 + 480q + 3840q^2 + 22240q^3 + 105120q^4 + \dots)$

Table C9. NS sector solutions of non-BPS type IV.

c	(μ_1, μ_2, μ_3)	NS sector character
10	$(\frac{3}{22}, -\frac{15}{176}, -\frac{10}{99})$	$q^{-\frac{5}{12}} (1 + 270q + 960q^{3/2} + 5725q^2 + 18304q^{5/2} + \dots)$
11	$(\frac{17}{84}, -\frac{187}{1344}, -\frac{55}{1008})$	$q^{-\frac{11}{24}} (1 + 275q + 1496q^{3/2} + 7931q^2 + 31240q^{5/2} + \dots)$
12	$(\frac{4}{15}, -\frac{1}{5}, 0)$	$q^{-\frac{1}{2}} (1 + 276q + 2048q^{3/2} + 11202q^2 + 49152q^{5/2} + \dots)$
$\frac{25}{2}$	$(\frac{31}{104}, -\frac{775}{3328}, \frac{25}{832})$	$q^{-\frac{25}{48}} (1 + 275q + 2325q^{3/2} + 13250q^2 + 60630q^{5/2} + \dots)$
13	$(\frac{25}{76}, -\frac{325}{1216}, \frac{169}{2736})$	$q^{-\frac{13}{24}} (1 + 273q + 2600q^{3/2} + 15574q^2 + 74152q^{5/2} + \dots)$
$\frac{27}{2}$	$(\frac{319}{888}, -\frac{2871}{9472}, \frac{225}{2368})$	$q^{-\frac{9}{16}} (1 + 270q + 2871q^{3/2} + 18171q^2 + 89991q^{5/2} + \dots)$
14	$(\frac{7}{18}, -\frac{49}{144}, \frac{7}{54})$	$q^{-\frac{7}{12}} (1 + 266q + 3136q^{3/2} + 21035q^2 + 108416q^{5/2} + \dots)$
$\frac{29}{2}$	$(\frac{117}{280}, -\frac{3393}{8960}, \frac{667}{4032})$	$q^{-\frac{29}{48}} (1 + 261q + 3393q^{3/2} + 24157q^2 + 129688q^{5/2} + \dots)$
15	$(\frac{91}{204}, -\frac{455}{1088}, \frac{55}{272})$	$q^{-\frac{5}{8}} (1 + 255q + 3640q^{3/2} + 27525q^2 + 154056q^{5/2} + \dots)$
$\frac{31}{2}$	$(\frac{125}{264}, -\frac{3875}{8448}, \frac{1519}{6336})$	$q^{-\frac{31}{48}} (1 + 248q + 3875q^{3/2} + 31124q^2 + 181753q^{5/2} + \dots)$
16	$(\frac{1}{2}, -\frac{1}{2}, \frac{5}{18})$	$q^{-\frac{2}{3}} (1 + 240q + 4096q^{3/2} + 34936q^2 + 212992q^{5/2} + \dots)$
$\frac{33}{2}$	$(\frac{391}{744}, -\frac{4301}{7936}, \frac{627}{1984})$	$q^{-\frac{11}{16}} (1 + 231q + 4301q^{3/2} + 38940q^2 + 247962q^{5/2} + \dots)$
17	$(\frac{11}{20}, -\frac{187}{320}, \frac{17}{48})$	$q^{-\frac{17}{24}} (1 + 221q + 4488q^{3/2} + 43112q^2 + 286824q^{5/2} + \dots)$
$\frac{35}{2}$	$(\frac{133}{232}, -\frac{4655}{7424}, \frac{6545}{16704})$	$q^{-\frac{35}{48}} (1 + 210q + 4655q^{3/2} + 47425q^2 + 329707q^{5/2} + \dots)$
18	$(\frac{25}{42}, -\frac{75}{112}, \frac{3}{7})$	$q^{-\frac{3}{4}} (1 + 198q + 4800q^{3/2} + 51849q^2 + 376704q^{5/2} + \dots)$
$\frac{37}{2}$	$(\frac{133}{216}, -\frac{4921}{6912}, \frac{2405}{5184})$	$q^{-\frac{37}{48}} (1 + 185q + 4921q^{3/2} + 56351q^2 + 427868q^{5/2} + \dots)$
19	$(\frac{33}{52}, -\frac{627}{832}, \frac{931}{1872})$	$q^{-\frac{19}{24}} (1 + 171q + 5016q^{3/2} + 60895q^2 + 483208q^{5/2} + \dots)$
$\frac{39}{2}$	$(\frac{391}{600}, -\frac{5083}{6400}, \frac{169}{320})$	$q^{-\frac{13}{16}} (1 + 156q + 5083q^{3/2} + 65442q^2 + 542685q^{5/2} + \dots)$
20	$(\frac{2}{3}, -\frac{5}{6}, \frac{5}{9})$	$q^{-\frac{5}{6}} (1 + 140q + 5120q^{3/2} + 69950q^2 + 606208q^{5/2} + \dots)$
$\frac{41}{2}$	$(\frac{125}{184}, -\frac{5125}{5888}, \frac{7667}{13248})$	$q^{-\frac{41}{48}} (1 + 123q + 5125q^{3/2} + 74374q^2 + 673630q^{5/2} + \dots)$
21	$(\frac{91}{132}, -\frac{637}{704}, \frac{105}{176})$	$q^{-\frac{7}{8}} (1 + 105q + 5096q^{3/2} + 78666q^2 + 744744q^{5/2} + \dots)$
$\frac{43}{2}$	$(\frac{39}{56}, -\frac{1677}{1792}, \frac{817}{1344})$	$q^{-\frac{43}{48}} (1 + 86q + 5031q^{3/2} + 82775q^2 + 819279q^{5/2} + \dots)$
22	$(\frac{7}{10}, -\frac{77}{80}, \frac{11}{18})$	$q^{-\frac{11}{12}} (1 + 66q + 4928q^{3/2} + 86647q^2 + 896896q^{5/2} + \dots)$
$\frac{45}{2}$	$(\frac{319}{456}, -\frac{4785}{4864}, \frac{735}{1216})$	$q^{-\frac{15}{16}} (1 + 45q + 4785q^{3/2} + 90225q^2 + 977184q^{5/2} + \dots)$
23	$(\frac{25}{36}, -\frac{575}{576}, \frac{253}{432})$	$q^{-\frac{23}{24}} (1 + 23q + 4600q^{3/2} + 93449q^2 + 1059656q^{5/2} + \dots)$
$\frac{47}{2}$	$(\frac{93}{136}, -\frac{4371}{4352}, \frac{5405}{9792})$	$q^{-\frac{47}{48}} (1 + 4371q^{3/2} + 96256q^2 + 1143745q^{5/2} + \dots)$

Table C10. R sector solutions of non-BPS type IV.

c	(μ_1, μ_2, μ_3)	R sector character
10	$(\frac{3}{22}, -\frac{15}{176}, -\frac{10}{99})$	$q^{-\frac{1}{6}} (5 + 1004q + 20510q^2 + 215000q^3 + \dots)$
11	$(\frac{17}{84}, -\frac{187}{1344}, -\frac{55}{1008})$	$q^{-\frac{1}{12}} (11 + 2026q + 45067q^2 + 518122q^3 + \dots)$
12	$(\frac{4}{15}, -\frac{1}{5}, 0)$	$24 + 4096q + 98304q^2 + 1228800q^3 + \dots$
$\frac{25}{2}$	$(\frac{31}{104}, -\frac{775}{3328}, \frac{25}{832})$	$q^{\frac{1}{24}} (25 + 4121q + 102425q^2 + 1331250q^3 + \dots)$
13	$(\frac{25}{76}, -\frac{325}{1216}, \frac{169}{2736})$	$q^{\frac{1}{12}} (52 + 8296q + 213148q^2 + 2875704q^3 + \dots)$
$\frac{27}{2}$	$(\frac{319}{888}, -\frac{2871}{9472}, \frac{225}{2368})$	$q^{\frac{1}{8}} (54 + 8354q + 221508q^2 + 3097278q^3 + \dots)$
14	$(\frac{7}{18}, -\frac{49}{144}, \frac{7}{54})$	$q^{\frac{1}{6}} (112 + 16832q + 459872q^2 + 6654592q^3 + \dots)$
$\frac{29}{2}$	$(\frac{117}{280}, -\frac{3393}{8960}, \frac{667}{4032})$	$q^{\frac{5}{24}} (116 + 16964q + 476876q^2 + 7131680q^3 + \dots)$
15	$(\frac{91}{204}, -\frac{455}{1088}, \frac{55}{272})$	$q^{\frac{1}{4}} (240 + 34208q + 988080q^2 + 15252000q^3 + \dots)$
$\frac{31}{2}$	$(\frac{125}{264}, -\frac{3875}{8448}, \frac{1519}{6336})$	$q^{\frac{7}{24}} (248 + 34504q + 1022752q^2 + 16275496q^3 + \dots)$
16	$(\frac{1}{2}, -\frac{1}{2}, \frac{5}{18})$	$q^{\frac{1}{3}} (512 + 69632q + 2115584q^2 + 34668544q^3 + \dots)$
$\frac{33}{2}$	$(\frac{391}{744}, -\frac{4301}{7936}, \frac{627}{1984})$	$q^{\frac{3}{8}} (528 + 70288q + 2186448q^2 + 36857568q^3 + \dots)$
17	$(\frac{11}{20}, -\frac{187}{320}, \frac{17}{48})$	$q^{\frac{5}{12}} (1088 + 141952q + 4516288q^2 + 78238080q^3 + \dots)$
$\frac{35}{2}$	$(\frac{133}{232}, -\frac{4655}{7424}, \frac{6545}{16704})$	$q^{\frac{11}{24}} (1120 + 143392q + 4661440q^2 + 82908000q^3 + \dots)$
18	$(\frac{25}{42}, -\frac{75}{112}, \frac{3}{7})$	$q^{\frac{1}{2}} (2304 + 289792q + 9616896q^2 + 175454208q^3 + \dots)$
$\frac{37}{2}$	$(\frac{133}{216}, -\frac{4921}{6912}, \frac{2405}{5184})$	$q^{\frac{13}{24}} (2368 + 292928q + 9914816q^2 + 185395456q^3 + \dots)$
19	$(\frac{33}{52}, -\frac{627}{832}, \frac{931}{1872})$	$q^{\frac{7}{12}} (4864 + 592384q + 20433664q^2 + \dots)$
$\frac{39}{2}$	$(\frac{391}{600}, -\frac{5083}{6400}, \frac{169}{320})$	$q^{\frac{5}{8}} (4992 + 599168q + 21046272q^2 + \dots)$
20	$(\frac{2}{3}, -\frac{5}{6}, \frac{5}{9})$	$q^{\frac{2}{3}} (10240 + 1212416q + 43335680q^2 + \dots)$
$\frac{41}{2}$	$(\frac{125}{184}, -\frac{5125}{5888}, \frac{7667}{13248})$	$q^{\frac{17}{24}} (10496 + 1227008q + 44597504q^2 + \dots)$
21	$(\frac{91}{132}, -\frac{637}{704}, \frac{105}{176})$	$q^{\frac{3}{4}} (21504 + 2484224q + 91757568q^2 + \dots)$
$\frac{43}{2}$	$(\frac{39}{56}, -\frac{1677}{1792}, \frac{817}{1344})$	$q^{\frac{19}{24}} (22016 + 2515456q + 94360576q^2 + \dots)$
22	$(\frac{7}{10}, -\frac{77}{80}, \frac{11}{18})$	$q^{\frac{5}{6}} (45056 + 5095424q + 194011136q^2 + \dots)$
$\frac{45}{2}$	$(\frac{319}{456}, -\frac{4785}{4864}, \frac{735}{1216})$	$q^{\frac{7}{8}} (46080 + 5161984q + 199388160q^2 + \dots)$
23	$(\frac{25}{36}, -\frac{575}{576}, \frac{253}{432})$	$q^{\frac{11}{12}} (94208 + 10461184q + 409710592q^2 + \dots)$
$\frac{47}{2}$	$(\frac{93}{136}, -\frac{4371}{4352}, \frac{5405}{9792})$	$q^{\frac{23}{24}} (96256 + 10602496q + 420831232q^2 + \dots)$

References

[1] A. A. Belavin, A. M. Polyakov, and A. B. Zamolodchikov, Nucl. Phys. B **241**, 333 (1984).
 [2] G. Anderson and G. Moore, Commun. Math. Phys. **117**, 441 (1988).
 [3] C. Vafa, Phys. Lett. B **206**, 421 (1988).
 [4] V. G. Knizhnik and A. B. Zamolodchikov, Nucl. Phys. B **247**, 83 (1984).
 [5] P. Ginsparg, Nucl. Phys. B **295**, 153 (1988).
 [6] R. Dijkgraaf, E. P. Verlinde, and H. L. Verlinde, Conformal field theory at $C = 1$, in *Nonperturbative Quantum Field Theory*, eds G. Int Hooft, A. Jaffe, G. Mack, P. K. Mitter, and R. Stora (Plenum Press, New York, 1988), p. 577.
 [7] P. Goddard and D. I. Olive, Algebras, lattices and strings, in *Vertex Operators in Mathematics and Physics*, eds J. Lepowsky, S. Mandelstam, and I. M. Singer (Springer, New York, 1985), p. 51.
 [8] S. D. Mathur, S. Mukhi, and A. Sen, Phys. Lett. B **213**, 303 (1988).

- [9] P. Durganandini, S. Panda, and A. Sen, Nucl. Phys. B **332**, 433 (1990).
- [10] S. Mukhi, [arXiv:1910.02973](https://arxiv.org/abs/1910.02973) [hep-th] [[Search INSPIRE](#)].
- [11] G. Moore and N. Read, Nucl. Phys. B **360**, 362 (1991).
- [12] X.-G. Wen, Natl. Sci. Rev. **3**, 68 (2016) [[arXiv:1506.05768](https://arxiv.org/abs/1506.05768)] [cond-mat.str-el] [[Search INSPIRE](#)].
- [13] K. Schoutens and X.-G. Wen, Phys. Rev. B **93**, 045109 (2016) [[arXiv:1508.01111](https://arxiv.org/abs/1508.01111)] [cond-mat.str-el] [[Search INSPIRE](#)].
- [14] M. R. Gaberdiel, H. R. Hampapura, and S. Mukhi, J. High Energy Phys. **1604**, 156 (2016) [[arXiv:1602.01022](https://arxiv.org/abs/1602.01022)] [hep-th] [[Search INSPIRE](#)].
- [15] H. R. Hampapura and S. Mukhi, J. High Energy Phys. **1607**, 138 (2016) [[arXiv:1605.03314](https://arxiv.org/abs/1605.03314)] [hep-th] [[Search INSPIRE](#)].
- [16] J.-B. Bae, K. Lee, and S. Lee, J. High Energy Phys. **1907**, 026 (2019) [[arXiv:1811.12263](https://arxiv.org/abs/1811.12263)] [hep-th] [[Search INSPIRE](#)].
- [17] J.-B. Bae, J. A. Harvey, K. Lee, S. Lee, and B. C. Rayhaun, [arXiv:2002.02970](https://arxiv.org/abs/2002.02970) [hep-th] [[Search INSPIRE](#)].
- [18] D. Gepner and A. Kapustin, Phys. Lett. B **349**, 71 (1995) [[arXiv:hep-th/9410089](https://arxiv.org/abs/hep-th/9410089)] [[Search INSPIRE](#)].
- [19] E. Rowell, R. Stong, and Z. Wang, Comm. Math. Phys. **292**, 343 (2009) [[arXiv:0712.1377](https://arxiv.org/abs/0712.1377)] [math.QA] [[Search INSPIRE](#)].
- [20] G. Y. Cho, D. Gang, and H.-C. Kim, J. High Energy Phys. **11**, 115 (2020) [[arXiv:2007.01532](https://arxiv.org/abs/2007.01532)] [hep-th] [[Search INSPIRE](#)].
- [21] D. Gaiotto and J. Kulp, J. High Energy Phys. **2102**, 132 (2021) [[arXiv:2008.05960](https://arxiv.org/abs/2008.05960)] [hep-th] [[Search INSPIRE](#)].
- [22] D. Gaiotto and A. Kapustin, Int. J. Mod. Phys. A **31**, 1645044 (2016) [[arXiv:1505.05856](https://arxiv.org/abs/1505.05856)] [cond-mat.str-el] [[Search INSPIRE](#)].
- [23] A. Kapustin and R. Thorngren, J. High Energy Phys. **1710**, 080 (2017) [[arXiv:1701.08264](https://arxiv.org/abs/1701.08264)] [cond-mat.str-el] [[Search INSPIRE](#)].
- [24] A. Karch, D. Tong, and C. Turner, SciPost Phys. **7**, 007 (2019) [[arXiv:1902.05550](https://arxiv.org/abs/1902.05550)] [hep-th] [[Search INSPIRE](#)].
- [25] L. Dixon, P. Ginsparg, and J. Harvey, Commun. Math. Phys. **119**, 221 (1988).
- [26] Y.-H. Lin and S.-H. Shao, J. Phys. A: Math. Theor. **54**, 065201 (2021) [[arXiv:1911.00042](https://arxiv.org/abs/1911.00042)] [hep-th] [[Search INSPIRE](#)].
- [27] I. Runkel and G. M. T. Watts, J. High Energy Phys. **2006**, 025 (2020) [[arXiv:2001.05055](https://arxiv.org/abs/2001.05055)] [hep-th] [[Search INSPIRE](#)].
- [28] C.-T. Hsieh, Y. Nakayama, and Y. Tachikawa, [arXiv:2002.12283](https://arxiv.org/abs/2002.12283) [cond-mat.str-el] [[Search INSPIRE](#)].
- [29] J. Kulp, J. High Energy Phys. **2103**, 124 (2021) [[arXiv:2003.04278](https://arxiv.org/abs/2003.04278)] [hep-th] [[Search INSPIRE](#)].
- [30] F. Gliozzi, J. Scherk, and D. Olive, Nucl. Phys. B **122**, 253 (1977).
- [31] I. Frenkel, J. Lepowsky, and A. Meurman, A moonshine module for the monster, in *Vertex Operators in Mathematics and Physics*, eds J. Lepowsky, S. Mandelstam, and I. M. Singer (Springer, New York, 1985), p. 231.
- [32] T. Johnson-Freyd, Tunisian J. Math **3**, 309 (2021) [[arXiv:1908.11012](https://arxiv.org/abs/1908.11012)] [math.QA] [[Search INSPIRE](#)].
- [33] J.-B. Bae, Z. Duan, K. Lee, S. Lee, and M. Sarkis, in press.
- [34] J.-B. Bae, Z. Duan, K. Lee, S. Lee, and M. Sarkis, in press.
- [35] T. Eguchi and H. Ooguri, Phys. Lett. B **203**, 44 (1988).
- [36] J.-P. Serre, *A Course in Mathematic* (Springer, New York, 1993).
- [37] K. Ranestad, J. H. Bruinier, G. van der Geer, G. Harder, and D. Zagier, *The 1-2-3 of Modular Forms* (Springer, Berlin, 2008).
- [38] A. R. Chandra and S. Mukhi, J. High Energy Phys. **1904**, 153 (2019) [[arXiv:1810.09472](https://arxiv.org/abs/1810.09472)] [hep-th] [[Search INSPIRE](#)].
- [39] P. Cvitanović, *Group Theory: Birdtracks, Lie's, and Exceptional Groups*, (Princeton University Press, 2008).
- [40] S. D. Mathur, S. Mukhi, and A. Sen, Nucl. Phys. B **318**, 483 (1989).
- [41] S. Lee and S. Lee, Nucl. Phys. B **956**, 115033 (2020) [[arXiv:1911.10391](https://arxiv.org/abs/1911.10391)] [hep-th] [[Search INSPIRE](#)].
- [42] S. G. Naculich, Nucl. Phys. B **323**, 423 (1989).
- [43] P. Goddard, A. Kent, and D. Olive, Commun. Math. Phys. **103**, 105 (1986).
- [44] J. A. Harvey and G. W. Moore, J. High Energy Phys. **2005**, 146 (2020) [[arXiv:2003.13700](https://arxiv.org/abs/2003.13700)] [hep-th] [[Search INSPIRE](#)].

- [45] I. Frenkel, J. Lepowsky, and A. Meurman, *Vertex Operator Algebras and the Monster*, (Academic Press, San Diego, 1988).
- [46] J. F. Duncan, [arXiv:math/0502267](https://arxiv.org/abs/math/0502267) [math.RT].
- [47] I. B. Frenkel and V. G. Kac, *Invent. Math.* **62**, 23 (1980).
- [48] G. Segal, *Comm. Math. Phys.* **80**, 301 (1981).
- [49] N. Benjamin and Y.-H. Lin, *SciPost Phys.* **9**, 65 (2020) [[arXiv:2005.02394](https://arxiv.org/abs/2005.02394) [hep-th]] [[Search INSPIRE](#)].
- [50] E. Witten, *Commun. Math. Phys.* **92**, 455 (1984).
- [51] D. Friedan, Z. Qiu, and S. Shenker, *Phys. Rev. Lett.* **52**, 1575 (1984).
- [52] G. Höehn and G. Mason, *J. Algebra* **448**, 618 (2016) [[arXiv:1505.06420](https://arxiv.org/abs/1505.06420) [math.GR]] [[Search INSPIRE](#)].
- [53] J.-B. Bae, S. Lee, and J. Song, *J. High Energy Phys.* **1712**, 045 (2017) [[arXiv:1708.08815](https://arxiv.org/abs/1708.08815) [hep-th]] [[Search INSPIRE](#)].
- [54] G. Hoehn, [arXiv:0706.0236](https://arxiv.org/abs/0706.0236) [math.QA].