

MAGNETIC FIELD OPTIMIZATION OF SIS100 QUADRUPOLE UNITS

K. Sugita*, E. Fischer, A. Mierau, P. Schnizer, GSI, Darmstadt, Germany
P. Akishin, JINR, Dubna, Russia

Abstract

Heavy ion synchrotron SIS100 in the FAIR accelerator complex consists of superconducting accelerator magnets. The SIS100 main quadrupole magnets are integrated into the quadrupole doublet modules together with the SIS100 corrector magnets and other beam related devices. In the SIS100 accelerator ring, 8 types of the standard modules and 3 special modules for the injection, extraction, and high radiation region are integrated. In this paper, an overview of the quadrupole modules and magnetic field optimization status of the superconducting magnets are reported.

SIS100 QUADRUPOLE MODULES

The SIS100 accelerator has six fold symmetry structure [1]. In the each sector, 14 cells are arranged. 3 straight section quadrupole modules are placed at cell 1, 2, 3. Both ends of these modules are closed by end caps and connected to cold warm transitions. The electric power current and coolant are supplied by superconducting bypass lines. The cells from no. 4 to 14 compose the cold arc section. In between the quadrupole modules, dipole modules [2] are inserted.

Table 1 is the summary of the modules. Several modules are commonly used in the different cells. All the sectors has common cell structure except the sector 5. In the sector 5, special modules are placed. From the injector SIS18 to the SIS100 ring, there is a special Y shape injection module at cell 14, sector 5. In this module, 2 additional injection quadrupole magnets are integrated, in addition to the standard cell 14 module. At the cell 4, there are Y shape extraction module is placed. This module contains 2 extraction quadrupole magnets as well. Upstream side of this module, namely cell 2 module at sector 5, is the highest radiation area therefore a room temperature module, which contains normal conducting magnets, is inserted. Up- and down-stream side of the cell 2, the quadrupole modules with special "star shape" vacuum chambers are installed.

Each doublet always consist of the defocusing quadrupole, focusing quadrupole, steering magnet, and beam position monitor. In addition, the chromaticity sextupole magnet, multipole corrector magnet [3], gamma-t jump quadrupole magnet, cryo-ion-catcher and other vacuum components are integrated.

MAIN QUADRUPOLE MAGNET

The SIS100 main quadrupole magnet is a superferric type magnet with a Nuclotron cable. The coil is 3 turns per pole and the pole tip radius is 50 mm. Total iron yoke length is 1.2 m. Maximum field gradient of 27.77 T/m

* k.sugita@gsi.de

Table 1: SIS100 Quadrupole Doublet Modules

Type	⇒ Beam direction ⇒				
	Upstream Unit		Downstream Unit		
Standard modules					
2.123	QD	BPM	ST	F2	
2.4	QD	BPM	ST	F2	MC
2.5	CV	QD	ST	F2	BPM
1.6A	BPM	QD	ST	F1	CH
1.7B	CV	QD	ST	F1	BPM
2.8C	BPM	QD	ST	F2	CH
2.9D	BPM	QD	ST	F2	QJ
1.E	MC	QD	ST	F1	BPM
Special modules in sector 5					
2.13s	QD	BPM	ST	F1	
2.4x	QD	BPM	ST	F2	MC
1.Ei	MC	QD	ST	F1	BPM

QD: Quadrupole defocusing, BPM: Beam position monitor, ST: Steering magnet, CH, CV: Chromaticity sextupole magnet, MC: Multipole corrector magnet, F1, F2: Quadrupole focusing family 1 and 2, QJ: Gamma-t jump quadrupole magnet

at the straight section is achieved with 10.512 kA electric current. Figure 1 shows the overview of the magnet.

The quadrupole magnet is the cores of the quadrupole doublet module. Other devices are mechanically attached to the quadrupole magnet. 2 quadrupole magnet in the doublet are mounted on the common girders and the girders are hung on the cryostat.

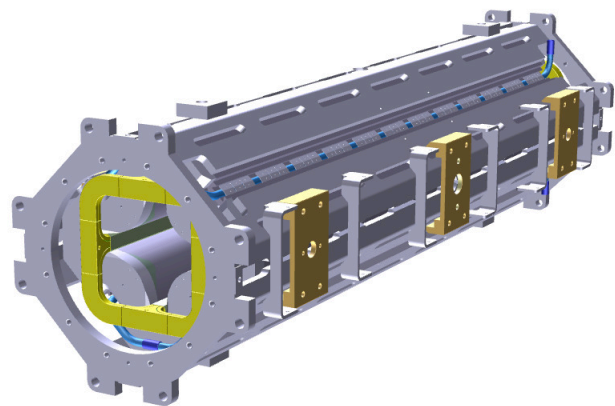

Figure 1: SIS100 main quadrupole magnet.

2D Magnetic Field

2D magnetic field quality is mainly defined by the pole profile of the iron yoke. Fundamentally this profile expressed as,

$$xy = \frac{\pm R^2}{2}. \tag{1}$$

Here the pole radius $R = 50$ mm was selected to match with required aperture size. In addition field optimization by shimming have been done.

To evaluate the field quality, 2D simulations of this magnet have been performed. The simulations were done by using ROXIE2D and OPERA. Figure 2 shows the cross section of the model.

Comparison of the results are shown in Fig. 3 and 4. Both simulations showed the good agreement.

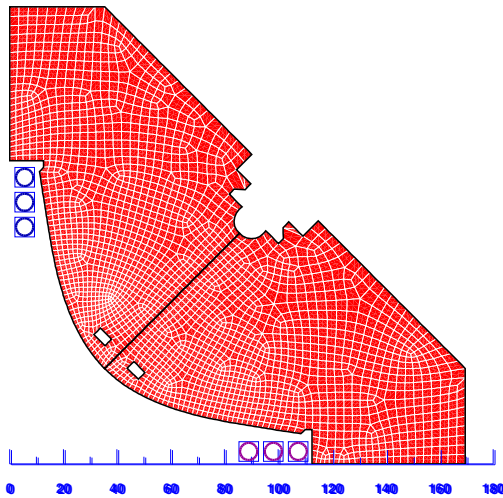

Figure 2: Cross section of the SIS100 main quadrupole magnet (quadrant) and the reference radius (40 mm).

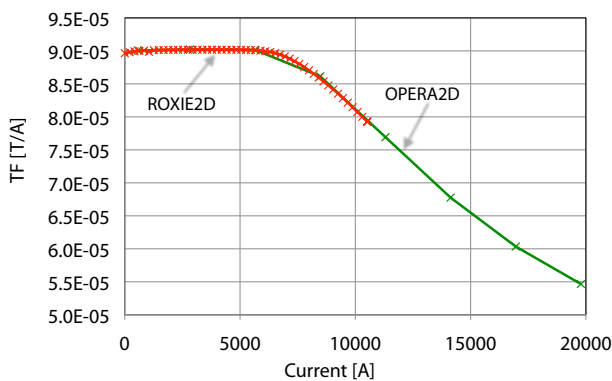

Figure 3: Transfer function of the quadrupole magnet. (Reference radius: 40 mm)

End Field Optimization

Generally connection side magnet end are asymmetric and induces systematic multipole field and magnetic field along the beam. Figure 5 shows the difference of the z component of the magnetic field (B_z) profiles at the connection

Figure 4: 1st and 2nd allowed multipole: b6 and b10. (Reference radius: 40 mm)

side and non-connection side. In order to minimize undesirable magnetic field components, optimization of the winding have done. Figure 6 shows the difference of the coil end. At the connection side end of the former design, there are two cables at the first and third quadrants, and there are four cables at the second and fourth quadrants. By the optimization, 3 cables in each quadrants are equally distributed.

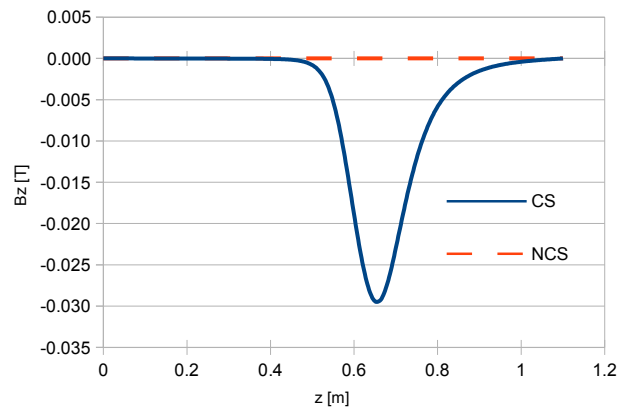

Figure 5: Magnetic field along beam axis (B_z) at the magnet aperture center at the connection side (CS) and non connection side (NCS). $I = 7.3$ kA.

Figure 6: Connection side end of the coil. Former (left) and latest (right) designs.

Cross Talk Between Unit Magnets

The two magnets, namely the SIS100 main quadrupole magnet and correctors, in the unit are integrated with relatively short distance. Stray magnetic field from the magnet to the other magnet may induces cross talk magnetic field. Typically the distance between the two magnet's iron yoke ends is 175 mm to 210 mm. Figure 7 shows the interconnection of the quadrupole magnet and chromaticity sextupole magnet. Computation results of the magnetic field of the magnet end showed this distance is enough to avoid the cross talks.

In between the magnets, there are metallic flanges to fix the magnets together. The eddy currents due to fast oscillated stray magnetic field in these flanges was evaluated by FEM model computations as shown in Fig. 8. It was concluded that the distortion to the beam is negligible [4].

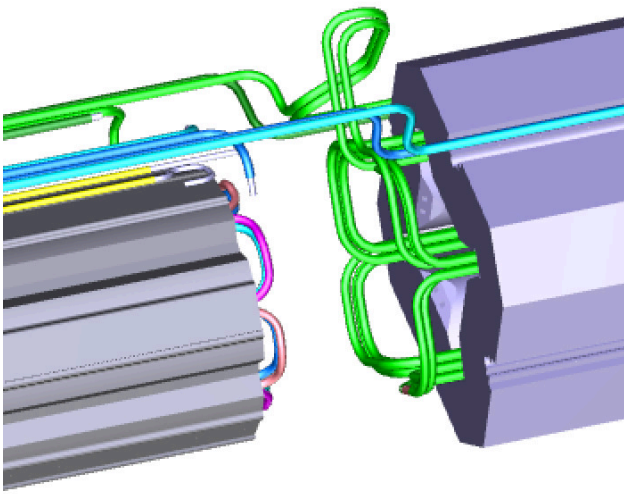

Figure 7: Iron yoke, coil and busbars of the quadrupole and chromaticity sextupole magnets at the interconnection region.

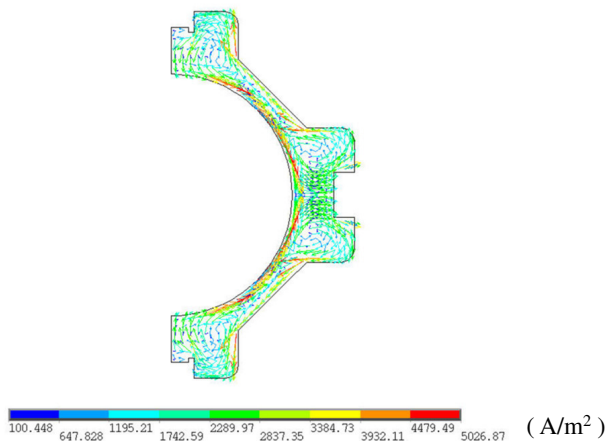

Figure 8: FEM model of the connection flange (half) of the quadrupole magnet.

FUTURE PLAN

Ahead of the series production of the quadrupole units, two units for the quadrupole doublet module type 2.5 (Table 1) will be manufactured and intensively tested. In addition one quadrupole magnet for the end field optimization will be manufactured. This magnet has block inserts at the non connection side end of the iron yoke. By replacing the inserts with several options of the end profile, and subsequent magnetic field measurements at the magnet end, final design of the profile will be decided. This pre-series works will be done by the end of 2015.

Concerning the magnets, the first version of the manufacturing designs were done. After pre-series magnet production and intensive testing, the series production will start.

In parallel, integration designs of all quadrupole doublet modules are ongoing. Especially, special Y shape modules are intensively designed based on the standard module design with modifications to avoid mechanical collisions. The integration design will be done at the middle of 2015.

After completion of the first doublet module and testing, the module will be integrated into the test string together with dipole modules and local cryogenic components to verify the performance of the superconducting system of SIS100 [5].

ACKNOWLEDGMENT

Authors would thank Dr. Shim from GSI for his work on the FEM simulations of the eddy current effects. Authors would thank all colleagues from GSI and JINR for the contribution to this work.

REFERENCES

- [1] FAIR Technical Design Report, <https://edms.cern.ch/file/987653/1/TDR-SIS100-Dec2008.pdf>
- [2] E. Fischer et al., "The SIS100 Superconducting Fast Ramped Dipole Magnet", IPAC'14, Dresden, Germany, June 2014, WEPRI083, These Proceedings.
- [3] K. Sugita et al., "3D Static and Dynamic Field Quality Calculations for Superconducting SIS100 Corrector Magnets", <http://JACoW.org/IPAC10/papers/mopeb027.pdf>
- [4] S. Y. Shim, "Eddy current and Quadrupole Magnet Connection-Flange", GSI PBMT Internal Note : PBMT-INT-SYS-2013-002_Eddy_QP_ConnectionFlange, July 2013.
- [5] K. Sugita et al., "String Test Preparation for the Superconducting SIS100 Accelerator of FAIR", IEEE Transactions on Applied Superconductivity, Volume:24, Issue: 3, June 2014, <http://ieeexplore.ieee.org/xpl/articleDetails.jsp?arnumber=6583237>