

UK INDUSTRIAL DEVELOPMENT OF MANUFACTURING TECHNIQUES FOR SUPERCONDUCTING RF CAVITIES

A.E. Wheelhouse, R.K. Buckley, L Cowie, P. Goudket, A.R. Goulden, P.A. McIntosh, ASTeC, STFC, Daresbury Laboratory, Warrington, UK

J. Everard, N. Shakespeare, Shakespeare Engineering Ltd, South Woodham Ferrers, Essex, UK

Abstract

An STFC Industrial Programme Support (IPS) Scheme grant, funding Daresbury Laboratory and Shakespeare Engineering Ltd to develop the capability to fabricate, process and test a 9-cell, 1.3 GHz superconducting RF cavity in support of enabling UK industry to address the large potential market for superconducting RF structures. At the heart of the development are the repeatability and the reproducibility of the manufacturing process in an effort to reduce the costs. Effort has been spent on developing the techniques to fabricate the niobium half-cells and the beam-pipes and this paper discusses the manufacturing processes and the results obtained.

INTRODUCTION

As part of a continuation of a Mini-IPS [1], a 3-year IPS [2] programme of work is being undertaken by ASTeC (Accelerator Science and Technology Centre) Department at Daresbury Laboratory, and Shakespeare Engineering Ltd [3]. The overall objective of the Science and Technology Facilities Council (STFC) Knowledge Exchange Programmes such as IPS, is to support the transferral of technology from the STFC funded laboratory research to UK industry. The initial programme of work was to develop the capability to manufacture and test a single-cell 1.3 GHz niobium cavity. A number of single-cell cavities were successfully fabricated and tested; PIPSS #01 achieved a gradient of 22.9 MV/m with a Q_0 of 1.06×10^{10} at 2K after buffer chemical polishing (BCP) [1] and during testing of cavity PIPSS #03 an accelerating gradient of 40 MV/m at a Q_0 of 1×10^{10} [2] was achieved after undergoing electro-polishing (EP) and centrifugal barrel polishing (CBP). Expanding on this original successful programme of work, the next stage aims to develop the ability to produce and test a 9-cell, 1.3 GHz Tesla style superconducting RF (SRF) cavity. This programme of work is being progressed in a number of stages:

- Development of the design and the drawings
- Fabrication of a prototype 2-cell copper cavity
- Fabrication and vertical testing of a 2-cell niobium cavity
- Fabrication and vertical testing of a 9-cell niobium cavity

To evaluate the success of the design and the fabrication it is planned to firstly perform BCP processing and then EP on the 9-cell cavity, with the target to achieve an accelerating gradient of greater than 20 MV/m at an unloaded quality factor, Q_0 better than 1.0×10^{10}

after BCP and a gradient greater than 30 MV/m after EP processing.

CAVITY DESIGN

As the purpose of this programme is to evaluate ability to fabricate and process the cavity cells, the design does not incorporate any coupler or higher order mode (HOM) ports, but does look at minimising the number of electron beam welds by removing the need to perform a seam weld on the beam-pipe. The design of the cavity is based on the Tesla cavity design, incorporating steps on the equator and iris interfaces. It is necessary when designing the step to not only consider the ease of parallelism of the equator planes to ensure the repeatability of mating half-cells together, but the possibility of trapping contamination during the electron beam weld process and therefore the likelihood of causing a hole. From lessons learnt during the electron beam welding of the single cell cavities particular care has been taken on the design of the step, minimising its depth to 0.4 mm so as to reduce the risk of trapping contamination.

FABRICATION

Beam-pipes

Previously with the single-cell cavities 3 mm thick niobium was used for the spinning of the beam-pipes. However, to minimise the risk of wall thinning for the 9-cell cavity 4 mm thick niobium is being used. Initial trials were performed with copper to prove the capability of the process, prior to the successful spinning of niobium beam-pipes (Fig. 1).

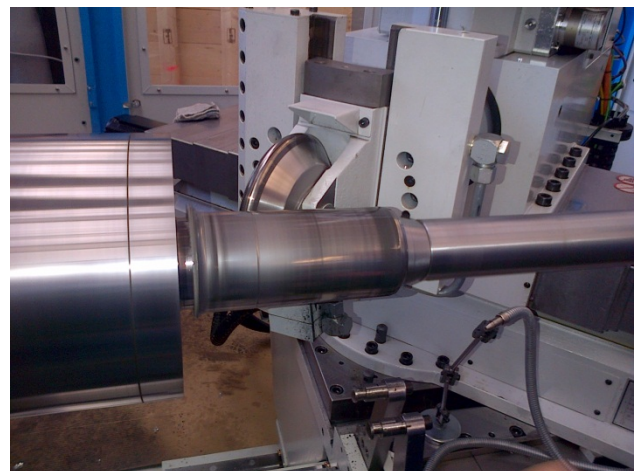

Figure 1: Niobium beam-pipe spinning.

Cavity

Deep-drawing tool dies have been manufactured from high carbon tool steel and trials have been performed with copper using a 60 tonne press, forming a number of centre and end-cells. Care and attention during the pressing process has been taken to minimise the wall thickness variability and spring-back, so as to maintain the roundness of the equator.

Frequency measurements were performed on the half-cells. An initial trial of frequency measurements performed on copper half-cells showed good reproducibility from the pressing of the half-cells. However, during the trimming stage inconsistencies were discovered in the repeatability of measuring individual half-cells, more than likely being due to the uneven pressure being exerted by the 3 external studs.

To provide an even pressure to the half-cells and dumb-bells during the frequency assessment process an improved fixture has been designed and built, which incorporates an in-house modified portable tuning press. A low cost commercially available, Clarke CSA10BB 10 t hydraulic press, was extensively modified in order to reduce the maximum available pressure to 2 t, so as not to distort the cells being measured and to reduce the weight for transportation by one person (Fig. 2). It is intended that the half-cells and dumb-bells are compressed between pressure plates to a pressure of 1 t to ensure good even contact. A repeat of the frequency measurements on spare half-cells is to be performed.



Figure 2: Press for frequency measurements of dumb-bells and half-cells.

To ensure the quality of the pressing dies and to check the manufacturing capability of spinning the beam-pipes a 2-cell copper cavity has been fabricated (Fig. 3). Excellent equator and iris interfacing of half-cells was noted when assembling all the sections, establishing good control of spring-back and thickness variability. CMM measurements have been performed to verify the cell shape (Fig. 4). The profile of both the end-cells and mid-cells can be seen to be within tolerance of ± 0.2 mm and when comparing each of the end-cells and each of the mid-cells with each other excellent consistency is seen.

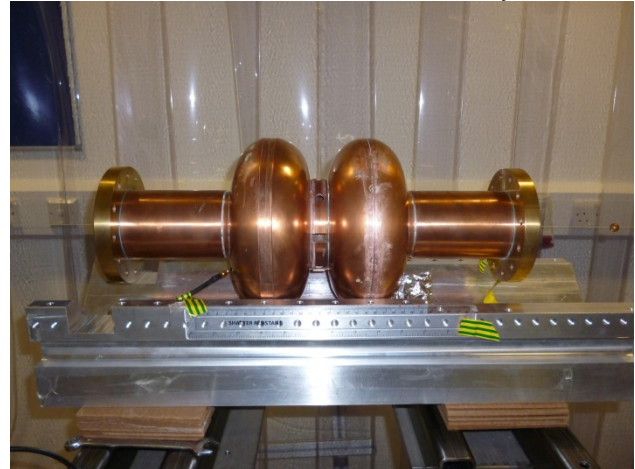

Figure 3: 2-cell prototype copper cavity.

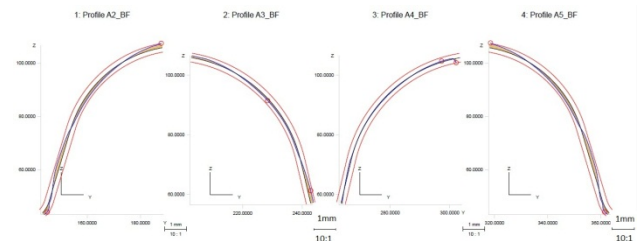

Figure 4: CMM profile of copper 2-cell cavity.

ELECTRON BEAM WELDING

Electron beam welding trials have been performed at a facility close to Daresbury Laboratory, Bodycote PLC [4], using a 150 kV 160 mA electron beam welder. The welding bay has been thoroughly cleaned to improve the welding pressure so as to meet the target pressure of 2×10^{-5} mbar and trials have been performed on niobium samples so as to develop the welding parameters.

Further trials are continuing on both flat plate samples as well as beam-pipes so as to fully optimise the parameters required for each of the weld types on a cavity. In addition, jigs are being currently designed to perform the electron beam welding of the 2-cell cavity.

FACILITY DEVELOPMENT

To enable the step from processing a single-cell cavity to that for a 9-cell cavity the facilities have been

expended to include a fully automated BCP facility and an automated high pressure rinse (HPR) stand.

Buffer Chemical Processing Facility

A BCP cabinet has been manufactured by Engenda Process Design Ltd [5] (formally S. J. Process Ltd), and installed at Daresbury Laboratory. The system is fully enclosed within a walk-in type of fume cupboard with an extraction system exhausted to an alkali scrubber, so as to minimise the risk to the operator of exposure to the hazardous chemical fumes. Improvements have been made to the etching process, with the inclusion of an inner narrow diameter shell within the cavity, so as to provide even flow of the acid over the cavity surface thus ensuring an even etch rate over the whole surface. A chilled water jacket surrounds the cavity to control the temperature of the exothermic reaction on the inner surface. The amount of material etched is to be measured ultrasonically. The system is controlled via a Siemens S7 PLC [6], for which the software has been fully implemented and tested.

High Pressure Rinse Facility

Additionally a fully automated ultra-pure water HPR stand based on a similar design to the stand at Fermilab, has been manufactured and installed in a room next to the BCP facility. The stand is designed for a water pressure of 1350 psi, and the water quality will be better than 18 MΩcm. It has a 1.5 m linear rail and the rinse nozzle wand has a maximum speed of 2 RPM.

Mechanical Cavity Tuning

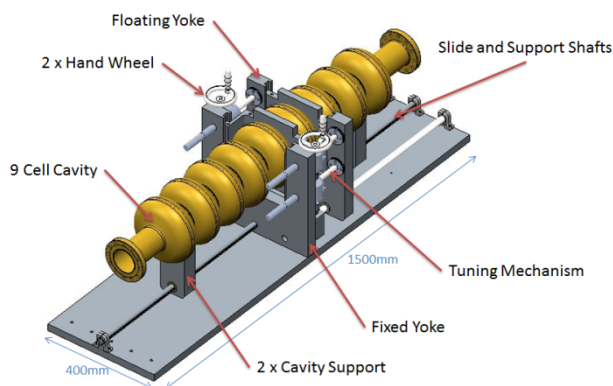

Figure 5: Mechanical cavity tuning fixture.

A manual mechanical cavity tuning fixture (Fig. 5) has been designed and procured. The system has been designed to provide a maximum tuning range of 4.5 mm. It consists of 2 yokes; one fixed and one floating. The floating yoke is supported by 2 precision linear bearings and cell tuning is achieved by adjusting the position of the floating yoke with respect to the fixed yoke. Split tuning plates slot into the yokes and clamp around the iris of the cavity. The tuner mechanism contains inter-connecting actuators, which ensure equal and opposite rotation so as to provide even tuning. The positions of the cavity

supports are adjustable to enable the tuning of the different cells. Measurement of the cells will be performed via bead-pull.

SUMMARY AND FUTURE PLANS

Having successfully produced a prototype 2-cell copper cavity, confirming that the pressing process of the dies can produce the required cell shapes for both the centre and end-cells, the tooling dies have been re-polished to ensure that they are free from any contamination. Pressing of the niobium half-cells and spinning of the niobium beam-pipes are about to commence at Shakespeare Engineering. Initially a 2-cell niobium cavity will be fabricated, so trials can be performed using the mechanical cavity tuning fixture, prior to manufacturing the 9-cell cavity. Further trials are to be performed using the in-house designed portable tuning press to refine the frequency measurement of the dumb-bells and half-cells to achieve a process that is repeatable.

ACKNOWLEDGMENT

The authors would like to acknowledge the collaborators at Jefferson Laboratory especially Bob Rimmer and Peter Kneisel and at Fermi National Laboratory, in particular to Camille Ginsburg and her team for their assistance and support provided.

REFERENCES

- [1] A.E. Wheelhouse et al, "Superconducting RF Cavity Development with UK Industry", SRF'11, Chicago, p. 464 (2011).
- [2] A.E. Wheelhouse et al, "Superconducting RF Cavity Development with UK Industry", SRF'13, Paris, p. 960 (2013).
- [3] Shakespeare Engineering Group, Unit 91, Haltwhistle Road, Western Industrial Area, South Woodham Ferrers, Essex, CM35ZA, UK.
- [4] Bodycote PLC, 18 Westgate, Skelmersdale WN8 8AZ, UK, www.bodycote.com
- [5] Engenda Process Design Ltd, Dee House, Hampton Court, Manor Park, Runcorn, Cheshire, WA7 1TT, UK; www.engenda-group.com
- [6] Siemens; www.siemens-automated.co.uk