

PAPER • OPEN ACCESS

Recent progress of cryogenic system for 40 T hybrid magnet

To cite this article: J Li *et al* 2015 *IOP Conf. Ser.: Mater. Sci. Eng.* **101** 012145

View the [article online](#) for updates and enhancements.

You may also like

- [Study on a Highly Stabilized Power Supply for Hybrid-Magnet Superconducting Outsert](#)
Jinglin Wu, , Jiaojiao Long et al.
- [Calculation of AC Losses of CICC for Superconducting Outsert Coils in a Hybrid Magnet](#)
He Peng, Chen Zhuomin, Chen Wenge et al.
- [Metal-as-insulation sub-scale prototype tests under a high background magnetic field](#)
Philippe Fazilleau, Benjamin Borgnic, Xavier Chaud et al.

Recent progress of cryogenic system for 40 T hybrid magnet

J Li, Z Ouyang, H Li, Q Meng, L Shi, X Ai, M Fang and X Chen

High Magnetic Field Laboratory, Chinese Academy of Sciences, Hefei 230031, China

E-mail: lijj@hfcas.ac.cn

Abstract. The 40 T hybrid magnet under construction at High Magnetic Field Laboratory of Chinese Academy of Sciences (CHMFL) consists of an 11 T superconducting outsert with clear bore of 800 mm and a resistive insert with clear bore of 32 mm. The outsert made of Nb₃Sn CICC is cooled with 4.5 K forced flow helium. The main cryogenic system includes a helium refrigerator (360 W at 4.5 K) and a helium distribution system for the cooling of coils, structures, transfer line and current leads. The helium refrigerator was successfully commissioned and put into operation in 2012. The helium distribution system installation will be completed in December 2015. This paper discusses the design of cryogenic system and recent progress in construction.

1. Introduction

As an important research tool, the magnetic field has been extensively used in such diverse disciplines as biology, chemistry, engineering, metallurgy, and physics. High magnetic fields may aid in new discoveries and contribute much to the fundamental knowledge and understanding of matters. Thus efforts are being made in many countries to establish higher magnetic field facilities. Adding a superconducting magnet outside a water-cooled resist magnet (commonly named hybrid magnet) has proved to be a cost-effective mean of achieving higher steady-state field. A hybrid magnet facility is planned for the High Magnetic Field Laboratory of Chinese Academy of Sciences in Hefei, China [1, 2]. The project which is specifically mandated by National Development and Reform Commission is under construction. The facility will be capable of producing more than 40 T steady field on axis in a 32 mm working bore. Approximately 29 T of the combined field will be produced by a water-cooled resistive insert. The superconducting outsert, which is fully based on Nb₃Sn cable-in-conduit conductor (CICC) technology will provide 11 T field in 800 mm room temperature bore. The superconducting outsert whose total cold mass is 11 tonnes will be cooled with forced flow of supercritical helium at 4.5 K, and stores 102 MJ energy at the nominal operating current of 14.5 kA.

The installation of helium cryogenic system for the hybrid magnet is close to the end. Commissioning of the hybrid magnet system will be finished in this year. This paper presents details of activities completed and undergoing on the helium cryogenic system.

2. LHe plant

The LHe plant was purchased from Air Liquide in 2011. Its cooling capacity is 360 W at 4.5 K in refrigeration mode, or it can produce 110 liters of liquid helium per hour in liquefaction mode. It has been in service in liquefaction mode for three years since its commissioning in early 2012. Each year, more than 40,000 liters of liquid helium has been produced and supplied to other cryogenic or superconducting facilities in the Lab. The gas helium evaporated is recovered by helium recovery



system, then purified and filled to storage tanks. Figure 1 shows the flow chart of the LHe plant and helium recovery system.

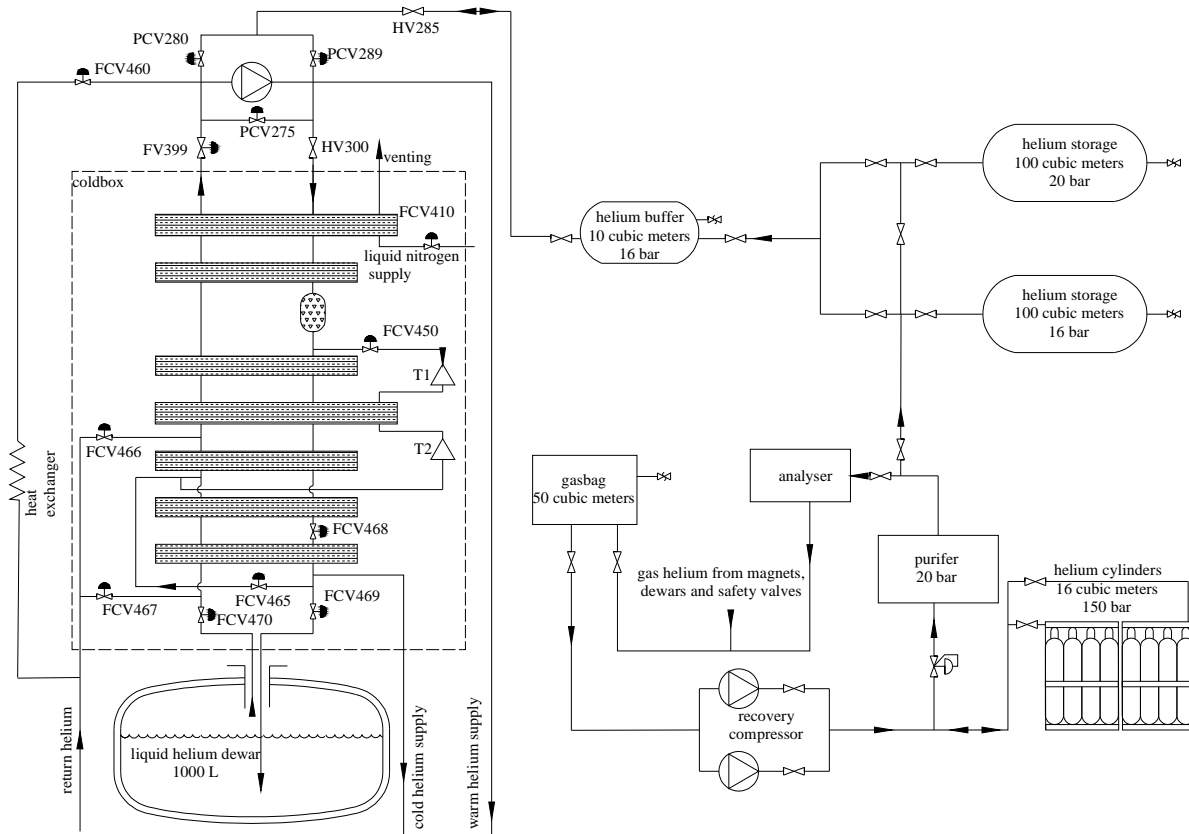

Figure 1. LHe plant and helium recovery system.

Also the LHe plant can operate in combined refrigeration-liquefaction mode. It is able to supply ~ 7 K helium with mass flow rate of no more than 18 g/s at 5 bar, and liquid helium produced will be used for cooling other experimental facilities.

3. Cryogenic circuit

One of the key requirements for the cryogenic system is the removal of the static heat loads deposited from external environment and joule heat of electric joints. The resistances of joints developed are lower than 3 n Ω [3, 4]. Another key requirement is the removal of transient AC losses of magnet system in cycling mode and trip scenarios. Table 1 shows the heat loads estimation for the cryogenic system during different operation modes. About 60% of cooling capacity will be consumed when the coils are cycled with the design ramp rate of 10 A/s.

Table 1. 4.5 K heat load (W) requirements.

	stand-by	10 A/s cycling	nominal operating
valve box	9.5	10.6	10.6
magnet cryostat [5]	39.6	132.9	43.9
busline	7	8.1	8.1
total	56.1	151.6	62.6
$\times 1.5$ (safety factor)	84.2	227.4	93.8

3.1. Superconducting coils

The superconducting outsert includes four series-connected coils, and the three inner coils (coil A, B and C) are layer wound, while the outer one (coil D) is pancake wound. A description of the superconducting coils is given in Table 2 [6, 7].

Table 2. Geometric parameters of coils.

	description	coil A	coil B	coil C	coil D
CICCs	jacket Dimensions (mm)	22×15	20.2×13.4	20.2×13.4	15×14.4
	number of strands(Cu/Sc)	160/80	105/75	60/120	36/108
	strands diameter (mm)	0.81	0.81	0.81	0.81
	twist angle (cos ϕ)	0.990	0.992	0.992	0.983
	fluid area (mm ²)	54.17	41.69	41.69	33.15
	void fraction	30.04%	30.59%	30.59%	30.46%
coils	inner radius (mm)	465	499	573.8	648.4
	outer radius (mm)	498	528.8	634.4	802.4
	winding type	layer	layer	layer	pancake
	number of layer/pancake	2	2	4	12
	maximum magnetic field (T)	12.732	11.353	10.051	7.745

All the coils are cooled by forced-flow helium at 4.5 K in a closed loop. The four coils are connected in parallel with control valves at the inlets, so mass flow through each coil can be controlled as needed. Flow coming from coil A, B and D enter busbars and supports for cooling before returning to the valvebox, but flow from coil C goes back to the valvebox directly.

In the cryogenic circuit design, the coils are totally divided into 26 cooling-channels which are hydro-dynamically connected in parallel. The inlet supply pressure is 5 bar, meanwhile the outlet pressure is stabilized at 3 bar (above the helium critical point of 2.27 bar) by PID controller. Distribution of mass flow in each channel at this pressure drops is shown in Table 3. Mass flow rate of coil A which is working in the highest field is up to 1.26-1.28 g/s.

Table 3. Mass flow rate calculation of each channel.

channels	inlet pressure (bar)	pressure drop (bar)	Length (m)	mass flow rate (g/s)
A-1	5	2	154.54	1.28
A-2	5	2	160.11	1.26
B-1	5	2	181.26	0.77
B-2	5	2	186.79	0.76
C-1	5	2	208.05	0.72
C-2	5	2	213.58	0.70
C-3	5	2	219.11	0.69
C-4	5	2	224.64	0.67
D1-18	5	2	182.32	0.62

3.2. Cryo-distribution box

The flow diagram of cryo-distribution system installed between the magnet and coldbox is shown in Figure 2. Detailed description of flow direction in different operating modes of the superconducting magnet is presented as follows.

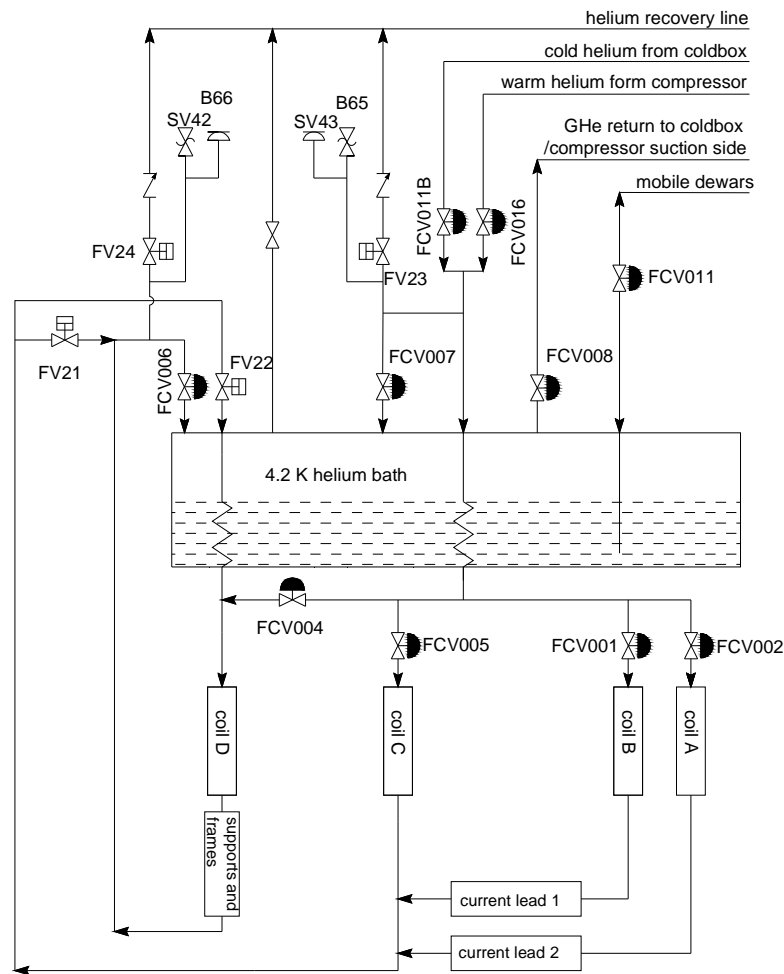

Figure 2. Cryogenic circuits of the cryo-distribution system.

3.2.1. Nominal operating mode

A J-T cooling type is used in nominal operating mode [8]. About 7 K of gas helium with pressure of 5.2 bar coming from coldbox flows into the heat-exchangers immersed in 4.3 K helium bath before distributed to cooling channels of the coils. Then the supercritical helium with temperature of 4.5 K is divided into four flows and get into the four coils separately. The mass flows are regulated by four cryogenic control valves. Strands of return helium flow together to the J-T valve FCV006. The upstream and downstream pressure of the coils is stabilized automatically by the two J-T valves of FCV006 and FCV007.

3.2.2. Fast charge/discharge mode

In nominal operating mode, even 10 A/s ramping mode when all the cooling channels are hydrodynamically connected in parallel (FV22 closed, FCV004 and FV21 open), the supplied maximum mass flow of 18 g/s can make the magnet stable effectively. However, when a higher ramping rate is needed, more mass flow is necessary for superconducting stability of coils. To increase the mass flow rate of helium inside each cooling channel, a series-parallel connection is designed (FV22 open, FCV004 and FV21 closed). The total 26 channels is divided into two groups: 8 channels in high field (coil A, B and C) and 18 channels in low field (coil D). Unlike the completely parallel connection, the

4.5 K supercritical helium firstly go through group 1, then enter group 2 before re-subcooled to 4.5 K by helium bath.

3.2.3. *Cooldown/warmup mode*

At the temperature above 80 K, to guaranty the acceptable level of thermal stress and mechanical safety of the coils, the maximum temperature difference among any parts should not exceed 50 K [9]. Therefore, cold gas should be mixed with a little of warm gas from HP side of main compressor before it flow into coils. The quantity of warm gas mixed is regulated by FCV016 according to the inlet and maximum temperature of the coils. The return gas can go optionally depending on its temperature to LHe buffer, heat exchanger of coldbox or LP side of the main compressor.

3.2.4. *Failure mode*

In the scenario of quenching or other failure condition, the pressure in the coil will increase rapidly to a very high value. Protection activities must be carried out in time before the facility is damaged. Three classes of protection method are configured for pressure relief in magnet quenching or such serious situations as loss of vacuum, unprotected quenching, water-cooled insert trip [10]. The setpoint of the automatical valves (FV23/24) is 6 bar. The setpoint of the safety valves (SV42/43) is 16 bar. The setpoint of the burst disks (B65/66) with diameter of 20 mm is 19 bar, and they are able to ensure that the maximum pressure in the coils do not exceed 19 bar at the most serious failure mode [11, 12].

4. Busline and HTS current leads

Figure 3 shows a layout view of the busline and HTS current leads which are for helium and current transfer. Inside the busline there are four pipes for helium feeding, two pipes for helium return, a pair of busbars and electrical joints. A vacuum barrier is located at the intermediate section in order to ensure the independence of the different vacuum system of magnet cryostat and cryo-distribution box.

A pair of HTS current leads which are mounted in the cryo-distribution box are connected with the two terminals of the coils through a pair of busbars. Helium from coil A and B goes into the busbars for cooling, and then out at the cold ends of the current leads. The HTS sections are cooled by liquid nitrogen, and the warm copper ends are cooled by city water. Temperature sensors and quenching detecting wires are installed for condition monitoring.

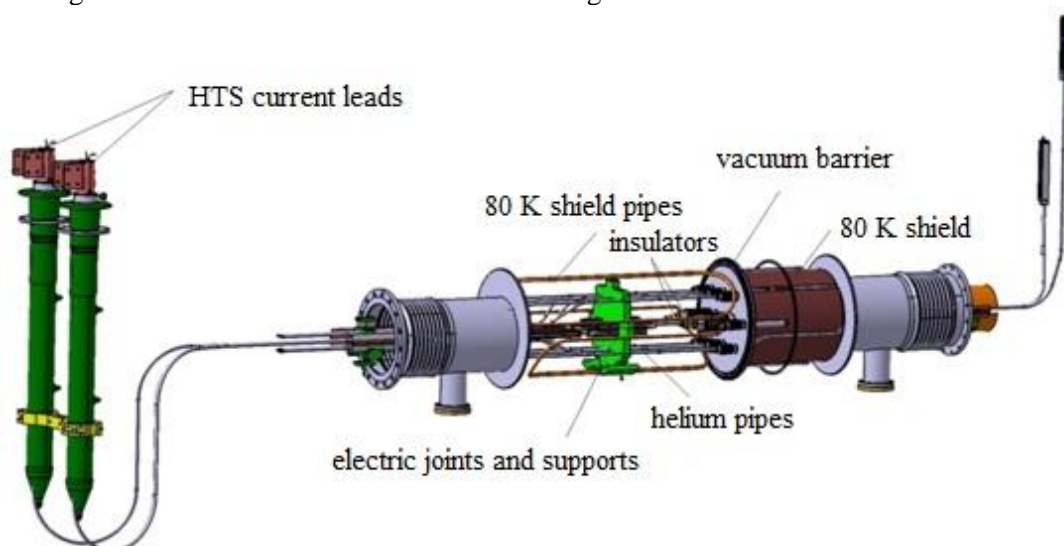

Figure 3. Layout view of the busline and HTS current leads.

5. Summary

As very important parts of the helium cryogenic system, the helium refrigerator and the helium recovery system have been in operation for three years, and totally supply more than 100,000 liters of liquid helium for experiments of other superconducting and cryogenic facilities. The recovery ratio of gas helium exceeds 90%.

Fabrication of coils, magnet cryostat, valvebox, current leads and busline is close to the end, and assembly work will begin in this August. Commissioning and combined commissioning with the superconducting magnet system will be carried out at the end of this year.

Acknowledgements

This work is supported by Chinese National Development and Reform Commission.

References

- [1] Tan Y, Chen W, Pan Y, Wang F, Chen Z M, Zhu J and Kuang G 2009 *IEEE Trans. Appl. Supercond.* **19** 3790-4
- [2] Kuang G 2010 *IEEE Trans. Appl. Supercond.* **20** 680-3
- [3] Tan Y, Chen W, Zhu J, Chen Z M, Pan Y, Wang F, Chen Z Y, He P, Ren Y and Kuang G 2011 *IEEE Trans. Appl. Supercond.* **21** 2020-3
- [4] Tan Y, Chen W, Chen Z Y, Zhu J, Huang P, Xu F and Kuang G 2015 *IEEE Trans. Appl. Supercond.* **25** 1-4
- [5] Zhu J, Chen W, Pan Y, Huang P and Kuang G 2014 *IEEE Trans. Appl. Supercond.* **24** 67-71
- [6] Tan Y, Wang X, Fang Z, Chen W, Qin J, Wang F, Pan Y, Chen Z M, Chen Z Y, Zhu J, Huang P, Zou G and Kuang G 2015 *IEEE Trans. Appl. Supercond.* **25** 1-4
- [7] Bottura L 1996 *J. Comput. Phys.* **125** 26-41
- [8] Zahn R and Heller R 2003 *Proc. 19th Int. Cryogenic Engineering Conf. (Grenoble, France, 2002)* ed Bagurer G and Seyfert P (New Delhi: Narosa Publishing House) pp 151-156
- [9] Bai H, Bird M D, Cantrell K R, Dixon I R and Gavrilin A V 2009 *IEEE Trans. Appl. Supercond.* **19** 1596-9
- [10] Bai H, Bird M D, Bole S T, Cantrell K R, Dixon I R, Gavrilin A V, Painter T A and Xu T *Advances in Cryogenic Engineering: Transactions of the Cryogenic Engineering Conf. (Tucson, USA, 28 June-2 July 2009)* vol 55 ed Weisend J (New York: AIP Publishing LLC) pp 1231-1238
- [11] Ren Y, Kuang G, Chen W, Wang F and Chen Z Y 2013 *IEEE Trans. Appl. Supercond.* **23** 19-25
- [12] Tan Y, Chen W, Xu F, Zhu J, Chen Z Y, Huang P and Kuang G 2014 *IEEE Trans. Appl. Supercond.* **24** 1-4