

CURRENT STATUS OF THE HIGH-POWER RF SYSTEMS DURING PHASE 2 OPERATION IN SuperKEKB

K. Watanabe[†], M. Yoshida, S. Yoshimoto, K. Marutsuka,
 High Energy Accelerator Research Organization, Tsukuba, Japan

Abstract

The SuperKEKB is an asymmetric-energy two-ring collider consisting of the high-energy ring (HER) for 7 GeV electrons and the low-energy ring (LER) for 4 GeV positrons at KEK. Both the electron and positron beams are injected from the Linac injector complex, which includes a newly constructed 1.1 GeV positron damping ring (DR) to supply a high-quality low emittance positron beams to the LER. The high-power rf system has a role to drive the rf cavities for the SuperKEKB. The operating frequency of rf system is 508.9 MHz. The required rf power from the klystron at maximum storage beam current is ~850 kW (CW). The number of rf stations is total 31 for the main ring (MR) and DR. The status of each high-power rf components, troubles of them and operation condition that occurred during phase2 commissioning from Feb 2018 to July 2018 will be reported in this paper.

INTRODUCTION

The SuperKEKB is an asymmetric electron-positron double-ring collider for B-factory at KEK [1]. The design beam current is 2.6 A (HER) and 3.6 A (LER) respectively. In order to corresponding to the large beam current and high beam power, reinforcement of the high-power rf system has been advanced. The high-power rf system in MR nad DR has the role of supplying rf power to the rf cavities, to compensate an enormous synchrotron radiation loss of electron and positron beams. The operating frequency is about 508.9 MHz and the required maximum rf power from one klystron with waveguide losses is ~850 kW (CW), it is a dependent on the cavity system. Many equipments that build high-power rf systems used in SuperKEKB are still many manufactured at TRISTAN [2], where construction was done in the early 1980s. There have been used for more than 30 years since manufacturing, and used while continuing maintenance. Figure 1 shows the location and number of rf stations for the operation. Table 1 shows the current status of the high power rf system.

CURRENT STATUS

A schematic diagram of structure of rf system is shown in Fig. 2. Two type systems are used for in MR and DR, which is one cavity or two cavities are driven by one klystron. In the first case, in order to isolate a cavity from the klystron, a 4 ports circulator is inserted. The rf power, after passing through the circulator, is directly input to the cavity in the underground MR tunnel. In the second case, to drive two cavities, a magic-tee is inserted from the

circulator to the cavities. The magic-tee is split to half amounts of power. The WR-1500 rectangular waveguide is used to deliver the rf power. Three kinds of high-power water or dummy loads are used at the circulator and the magic-tee to absorb the reflected rf power from the cavity. Both normal conducting cavities (NCC) and superconducting cavities (SCC) are used for MR. The NCC, which is called ARES [3], has a unique structure for the KEKB in order to avoid the coupled-bunch instability caused by the accelerating mode. The SCC is single-cell cavity with a large aperture beam pipe and a ferrite HOM absorbers [4]. In the DR, two single cell NCCs with SiC HOM damper (called DR cavity) [5] are used from phase2 in order to make the emittance significantly smaller. Two type of Low level RF control systems are used to control V_c in the cavities which is new digital control systems and the existing old systems for SuperKEKB [6, 7].

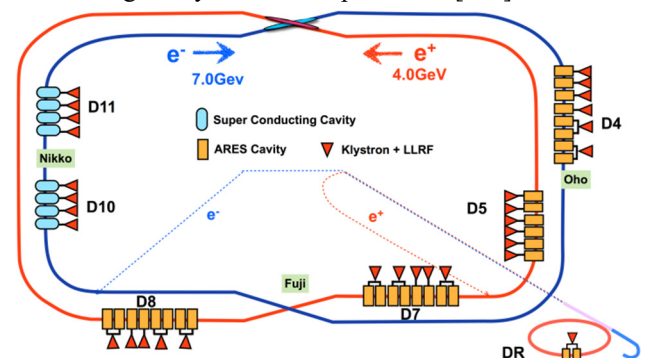

Figure 1: RF stations in MR and DR. Total 31 stations are using for phase 2 commissioning.

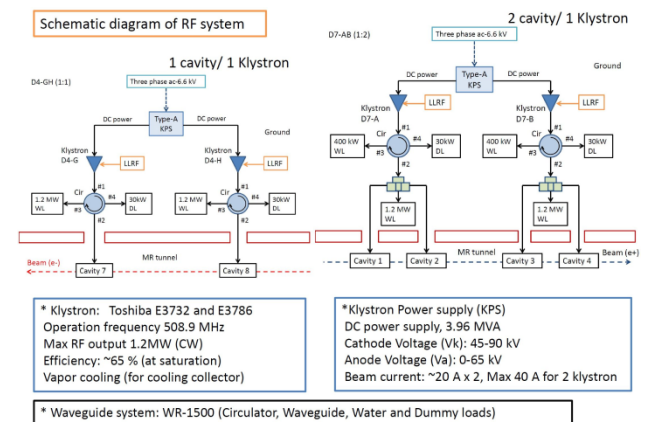

Figure 2: A schematic diagram of rf system.

Total V_c of LER, HER and DR are 8.8 MV, 12.8 MV and 1.0 MV in phase2. The V_c per cavity for NCC, SCC and DR cavity is 0.4 MV, 1.2 MV and 0.5 MV. Required rf power to hold total V_c with waveguide losses is about

[†] kenw@post.kek.jp

Content from this work may be used under the terms of the CC BY 3.0 licence (© 2019). Any distribution of this work must maintain attribution to the author(s), title of the work, publisher, and DOI

3.4 MW for LER, 2.0 MW for HER and 125 kW for DR (see Fig. 3). Maximum stored beam current was achieved 860 mA in LER and 800 mA in HER, respectively [1]. In this time, the supplied total rf power for both ring was 4.5 MW in LER and 3.8 MV in HER.

The efficiency of each klystron at idol was 10 ~ 45%, it is dependent on the amount of output rf power, and determines by design of klystron. Total efficiency of rf power sources was 32.4% in LER and 24.8% in HER. During beam operation, total efficiency was improved to ~ 40% increasing by required rf power. We assume that the efficiency of rf power source reaches to ~ 60% when the design beam current is stored in both ring.

Table 1: Current Status of High Power RF System

Items	Status
Frequency	508.9 MHz
Operation	CW
Number of RF station	MR: 30 (36)* DR: 1
Klystron	Test station: 6
	Total 31 (37)*
	E3786: 17 E3732: 14
KPS	*Maximum rf output power: 1.2 MW
	*Maximum efficiency: 65%
	Type-A: 15 (17)* Type-B: 2 (1)* For the test stations: five type-B KPS
Waveguide	WR-1500
Circulator	1MW UHF 4-port circulator Total 31 (37)*
Loads	1.2 MW water-load: Total 30 (36)* Rectangular-type -> 18 (24)* Cylindrical-type -> 12
	400 kW water-load: 9 (5)*
	30-50 kW coaxial dummy load: 31 (37)*
Required RF power	MR: Max 850 kW/klystron DR: Max 500kW/klystron
	Number of cavity

()*: in the future.

Klystron

Currently used CW high-power klystrons are of two types, E3732 (late-model) and E3786 fabricated by Toshiba Electron Tubes & Device Co., Ltd [8]. A total 41 klystrons (include spear) are keeping for SuperKEKB, there are combining two models fabricated in 1987-2013. If E3786 is broken, then it can repair to E3732 specifica-

tion. Longest operation time of these klystrons is about 11×10^4 hours, it is working now since early stage of TRISTAN at 1986 (see Fig. 4). The average operation time of E3786 and E3732 is 6×10^4 and 1.8×10^4 hours (Maximum: 8×10^4). The E3732 were fabricated from 2003, the specification of this model achieves high stability and long life expectancy, because of the any klystron failures never occurs since initial lot.

Water leak was happened on a cooling pipe of klystron body from two klystrons at Feb and Mar 2018. They were repaired in house using by repairing materials.

Fabrication of one klystron using new ceramic rf window for output coupler (Manufactures have changed) is planning at 2019-2020 or later, it is very important to design a plan of the manufacturing in the future.

Klystron Power Supply (KPS)

The dc power supply systems were manufactured by Toshiba Corp, and NICHICON Corp. is used to drive 1 MW high-power klystrons [9]. Two kinds of KPS called type-A and type-B were built since 1984. For SuperKEKB, two type-A KPSs were built at 2012 and 2014 before starting phase1. Total fifteen type-A and two type-B KPSs use for phase2. The type-A is designed for driving two klystrons with common cathode voltage, and the type-B is designed for only one klystron. A three phase ac-6.6 kV power line is fed to KPS. The structure of KPS is simple rectifying circuit with VCB, IVR, 12 phase full-wave rectifier (3.96 MVA for type-A), smoothing capacitor (Ripple < 0.5%) and a cathode-heater-anode power supply. A crowbar circuit by using five mercury pool ignitrons is installed to release an enormous energy stored in the smoothing capacitor of cathode voltage, when arcs may happen inside the klystron.

The concern at this time is the failure of the rectifier on high voltage section. In the analysis of insulating oil in rectifier, no abnormality is found in electrical characteristic, but ethane, which is one of the items showing aged deterioration, is increasing. Frequent inspection for the high voltage section is necessary.

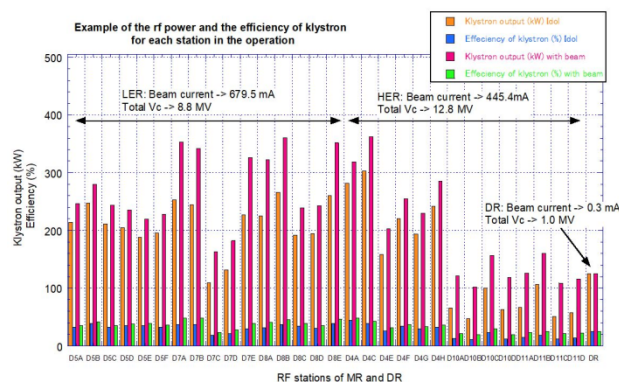

Figure 3: Example of the amount of rf power and the efficiency of klystrons for each station in the operation.

Circulator

A four-port circulator has been constructed by employing a magic-tee, 3-dB coupler and a pair of rectangular

waveguide nonreciprocal phase shifter (manufactured by SPC ELECTRONICS Corp.) [9]. Total 31 circulators were used for rf stations. 23 of 31 circulators, there are fabricated at 1984-1987. 12 of 23, these circulators were done the overhaul to repair a water leak from cooling channel on the phase shifter. As time goes on, the number of cooling water channel that cause leakage of circulator which have not overhauled is increasing due to corrosion by aging. For repair, there is a limit on the cuttable range of cooling water channel. So, new production is necessary.

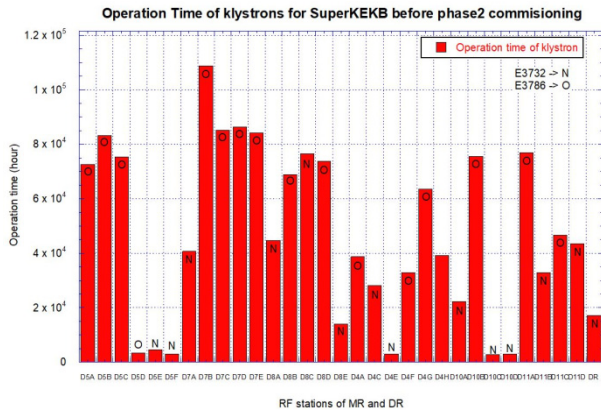

Figure 4: Total operation time of klystrons since fabrication or repair before phase2 commissioning.

Waveguide System and Loads

We are planning to update a waveguide which is manufactured at the early stage of construction of TRISTAN. Currently, there are only a few remaining in the Fuji area (D7 and D8). All of the dummy loads made at TRISTAN were broken, so they were discarded. All dummy loads were updated from direct water cooling type to the indirect water cooling to achieve long life time.

Two types of high-power water-load were used which is employ the eighteen rectangular-type and the twelve cylindrical-type for SuperKEKB [10, 11]. The water leakage due to corrosion of seal material was detected for all rectangular-type water-loads after the end of KEKB. The cause of corrosion is that a tap water (~360 $\mu\text{S}/\text{cm}$) was used as a microwave absorber. For the long time operation without corrosion, the water quality is changed from the tap water to the mixed water (~20 $\mu\text{S}/\text{cm}$) and controls the conductivity in water. Gold coated on the surface of metal seal is employed to the water-loads for improvement sealing performance and corrosion resistance. A water leak trouble was happened from two cylindrical-type water-loads during phase2. The cause of water leak is that a ceramic rf windows was broken by mechanical stress. One rf station was retuned changing by a spare after drying the inside waveguide system by a blower. Another rf station, it was separated from operation, because of, there was no spare of the water-load.

Cooling System for Klystron

A cooling of the collector of klystron was employed the vapor cooling system, it was built and used since TRIS-

TAN [9]. A hot water in reservoir tank is supplied to the collector for cooling by using a canned motor pump. The steam produced at each collector is transferred by a common stainless pipe to the air cooled heat exchanger (ACHE). The condensed water retunes back mainly to the water level tank. The ACHE is placed on the roof of each area (D4, D5, D7, D8, D10 and D11). The temperature of collector during operation is kept less than 110 $^{\circ}\text{C}$. The our vapor cooling system is working well without serious trouble.

CONCLUSION AND FUTURE PLAN

Many equipments have been used for more than 30 years since manufacturing, and used while continuing maintenance. We must be considered how the high-power rf system survives more than 10 years without serious trouble. To repair for each aing component, a technique and a know-how are developing with manufacturers to reduce a running cost for the operation. And the frequent inspection is also necessary to achieve the stable operation for SuperKEKB.

REFERENCES

- [1] Y. Ohnishi *et al.*, “Report on SuperKEKB Phase2 Commissioning”, in *Proc. 9th Int. Particle Accelerator Conf. (IPAC’18)*, Vancouver, BC, Canada, Apr.-May 2018, pp. 1-5. doi:10.18429/JACoW-IPAC2018-MOXGB1
- [2] T. Nishikawa *et al.*, “Status of KEK TRISTAN Project”, in *IEEE Transactions on Nuclear Science*, Vol. NS-30, No.4, Aug. 1983, pp. 1983-1987.
- [3] T. Kageyama *et al.*, “THE ARES Cavity for the KEK B-Factory”, in *Proc. EPAC’96*, Santiago Lago, Spain, Jun. 1996, WEP054L.
- [4] M. Nishiwaki *et al.*, “Development of HOM Dampers for SuperKEKB Superconducting Cavity”, in *Proc. SRF’13*, Paris, France, Sep. 2013, pp. 1058-1060, THP061.
- [5] T. Abe *et al.*, “RF Accelerating Structure for the Damping Ring of the SuperKEKB Injector”, in *Proc. IPAC’10*, Kyoto, Japan, May 2010, pp. 3548-3550, WEP087.
- [6] T. Kobayashi *et al.*, “Operation of LLRF Control Systems in SuperKEKB Phase-1 Commissioning”, in *Proc. IPAC’2017*, Copenhagen, Denmark, May 2017, pp. 3986-3988, THPAB114.
- [7] T. Kobayashi *et al.*, “LLRF Control and Master Oscillator System for Damping Ring at SuperKEKB”, in *Proc. IPAC’18*, Vancouver, BC, Canada, May. 2018, pp. 2137-2139. doi:10.18429/JACoW-IPAC2018-WEPAL001
- [8] S. Isagawa *et al.*, “Operation of the UHF CW Klystron at the World’s Highest Power Level”, in *Proc. 14th Symposium on Accelerator Science and Technology*, Tsukuba, Japan, Nov. 2003.
- [9] M. Ono *et al.*, “TRISTAN RF System with Normal Conducting Cavity”, in *KEK Internal report 87-6*, Dec, 1987.
- [10] K. Watanabe *et al.*, “Development of Cylindrical-type 1.2 MW High Power Water-load for SuperKEKB”, in *Proc. IPAC’13*, Shanghai, China, May 2013, pp. 3318-3320, THPFI013.
- [11] Y. Arisumi *et al.*, “Development of 1.2 MW High Power Water Load”, in *Proc. the 12th Symposium on Accelerator Science and Technology*, Wako, Japan, 1999.