

# SIDE EFFECTS OF BUNCH-BY-BUNCH FEEDBACK SYSTEM ON SuperKEKB COLLIDER

M. Tobiya<sup>†,1</sup>, T. Ishida, KEK Accelerator Laboratory, 1-1 Oho, Tsukuba, Japan  
<sup>1</sup>also at Department of Accelerator Science, SOKENDAI, Tsukuba, Japan

## Abstract

The bunch-by-bunch feedback system is now a key function in high-current, multi-bunch storage rings, suppressing coupled-bunch instability and/or reducing the effects of injection vibration. In high-luminosity  $e^+e^-$  colliders, such as SuperKEKB, strong beam-beam interactions occur due to collisions, which typically introduce an extensive frequency response to the transverse bunch motion far off the betatron tune. In the vertical plane it may cause an increase of the beam size, which has a significant impact on the luminosity. In this paper, we will present the principles and configuration of our bunch feedback system, the causes of its side effects, and several trials aimed at overcoming them.

## INTRODUCTION

On recent high-luminosity colliders, such as the SuperKEKB collider, it is almost indispensable to use robust transverse bunch-by-bunch feedback systems to suppress fast coupled-bunch instabilities (CBI) arising from strong and wide-band impedance sources, including electron cloud instability or fast ion instability. The feedback gain of the systems tends to be rather large, at least to keep the beam in single beam condition. In the case of SuperKEKB-LER, we usually have set the gain of the system to have the feedback damping time of around 0.5-1 ms, which corresponds to 50 to 100 turns of the revolution of the rings.

During the operation of the KEKB collider, we have unexpectedly observed a degradation of the luminosity related to the excess feedback gain of the LER [1]. Through our detailed study of how the transverse feedback gain relates to the luminosity, we discovered that the vertical feedback gain influences both luminosity and vertical beam size. In contrast, other transverse feedback gains did not show a clear correlation with luminosity or beam size. We have also examined the effect of the vertical feedback gain on vertical beam size observed with the interferometer on both the collision and on the single-beam condition of KEKB-LER. Though the vertical beam size slowly increased ( $\sim 10\%$ ) with the feedback gain during the single beam condition, it jumped up more than 40% with a slight change in the feedback gain during the collision. The resulting luminosity decreased by around 10 to 20% with the blowup of the vertical beam size.

Numerical simulations have shown that the significant beam-beam effect enhances small oscillations induced by the broadband noise of the bunch feedback systems [2]. This effect is thought to be more pronounced in colliders with a small vertical beam emittance, so sufficient

consideration was given to the design of the bunch feedback systems from the SuperKEKB accelerator. Unfortunately, we have still observed the effects on luminosity due to the bunch feedback gain.

In this report, we will at first give an overview of the effects of the injected feedback noise observed in the KEKB collider. Secondly, the bunch feedback system for the SuperKEKB will be presented, with a focus on the bunch position detector circuit, where it has the most significant influence on the system's noise figure. The experimental results from the 2024c runs, which began after summer break and continued until the end of 2024, along with the plans, will be presented. The main parameters of SuperKEKB rings in 2024c runs are listed in Table 1.

Table 1: Machine Parameters Achieved at SuperKEKB

Parameters	LER	HER
Energy (GeV)	4	7
Circumference (m)		3016
Beam current (A)	1.632	1.259
$n_b$		2346
$I_b$ (mA)	0.696	0.537
$\beta^*_x$ (mm)	60	60
$\beta^*_y$ (mm)	1.0	1.0
$\xi_y$	0.036	0.027
H. size $\sigma_x^*$		15.5
V. size $\sigma_y^*$ ( $\mu\text{m}$ )		0.265
$\beta_x/\beta_y$ at FB monitors (m)	19.4/20.0	13.4/29.7
$\beta_x/\beta_y$ at FB T kickers (m)	23.4/9.9	13.4/29.7
T. rad D-time (ms)	43	58
CW ratio	80%	60%
$L_{\text{peak}}$ ( $\text{cm}^{-2}\text{s}^{-1}$ )		$5.1 \times 10^{34}$

## OVERVIEW OF NOISE EFFECT OBSERVED AT KEKB

It is not easy to excite a beam in the transverse plane at a frequency other than the betatron frequency unless it is an extremely low frequency. Therefore, even if the broadband noise injected by the bunch feedback system is quite large, it will not affect the beam. However, if the beam-beam effect due to collision is significant, this situation changes, and the response of the beam is thought to be wide over a range from the betatron frequency to the beam-beam tune shift value. As the beam-beam effect is quite nonlinear, this effect will behave nonlinearly in both the frequency range and the amplitude.

<sup>†</sup> makoto.tobiya@kek.jp

The systematic study of the effect of noise in the bunch feedback system on the vertical beam size and the luminosity has been studied in the KEKB [1]. The left side of Fig. 1 shows the excited vertical beam amplitudes with fixed excitation voltage by the excitation tune. The fractional part of the vertical betatron tune at that time was 0.58. It also shows that though the so-called beam-beam region around 0.6, which spans from the vertical tune to the beam-beam tune shift value, is more sensitive to small external signals than to large ones, other areas far from the betatron tune responses are not negligible. The measured drop of the luminosity by excited vertical amplitude with several excitation frequencies is shown in the right side part of Fig. 1. At the beam-beam region, the KEKB-LER beam size has increased quickly, and the luminosity has gradually decreased with the excitation amplitude. On the other hand, out of the beam-beam region, though the increase of the KEKB-LER beam size was much slower than that of the beam-beam region, the drop of the luminosity with the excitation amplitude was somewhat milder.

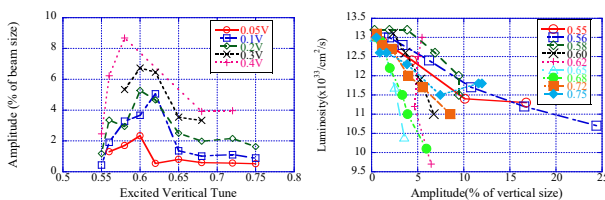

Figure 1: Beam response with the excited tune (left) and luminosity degradation due to oscillation applied externally in the feedback system (right) at KEKB-LER.

## BUNCH FEEDBACK SYSTEMS FOR SuperKEKB RINGS

All of the bunch feedback equipment is installed in the Fuji crossing area [3]. Each ring has two sections of position monitors. Stripline-type kickers for transverse deflection are installed upstream of the first monitor chamber. We use two transverse kickers with lengths of 41 cm. We have also installed four over-damped longitudinal kickers (DAΦNE-type kickers) in the LER, each with two input ports and two output ports.

A block diagram of the original transverse and longitudinal bunch feedback system is shown in Fig. 2. Since the fractional part of the betatron tune on both horizontal and vertical planes may be very near to the half-integer to maximize luminosity, we have prepared a double feedback loop in the transverse planes with a betatron phase advance between monitor chambers of around 90 degrees.

We have installed two feedback monitor chambers per ring, each equipped with 24-button electrodes, utilizing glass-type sealing for enhanced time response. The 2 GHz component of a bunch signal is filtered using a comb-type bandpass filter, then down-converted to a DC signal after a 180-degree hybrid by mixing it with a signal of 4 times the RF frequency. Bunch-by-bunch residual DC offset is cancelled by adding the sum signal to cancel the offset. We have used a DC amplifier (THS4303) after the Bessel-type

low-pass filter to suppress the large signal offset after the bunch train gap transient.

The iGp12 [4] digital feedback filters have been utilized for signal processing in bunch feedback systems. The rejection of the DC component, adjustment of the feedback phase, and one-turn delay, along with real-time diagnostics of the beam using a grow-damp function, have been implemented. In total, 10 processors (8 for transverse, 2 for longitudinal) have been used.

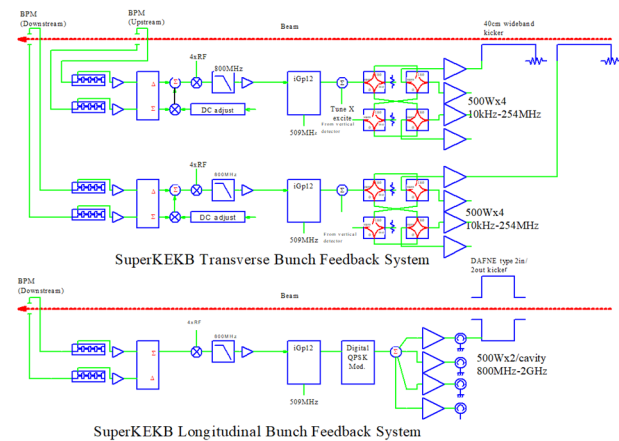

Figure 2: Block diagram of original SuperKEKB bunch feedback systems.

In SuperKEKB rings, the threshold of the coupled-bunch instability (CBI) is low, less than 30 mA in a regular bunch-filling pattern. The typical transverse growth time of CBI is less than 1 ms, corresponding to approximately 100 turns of revolution of a bunch. The transient-domain and unstable mode analysis has estimated the source of the CBI. In HER, the unstable mode behaves similarly to the fast ion instability (FII) and the resistive wall mode. In LER, we observe electron-cloud instability (ECI) related modes and resistive wall instability-related modes. By tuning the feedback gain of the SuperKEKB bunch feedback systems to exceed the growth rate of the CBI, we successfully suppressed the CBI with the maximum beam current using a designed (by 2) bunch-filling pattern.

## DECREASE IN LUMINOSITY DUE TO VERTICAL FEEDBACK GAIN

During the collision operation of SuperKEKB, we observed that the luminosity decreased with an increase in the vertical feedback gain in both the HER and LER. With sufficient room in the feedback gain for beam stabilization, we could lower the gain to the point where almost no effect has been observed on the luminosity. In this situation, the rms count to the iGp12 ADC exceeded 13 counts without the beam, which is too large even considering the circumstances necessitating increased circuit gain due to the longer ring circumference and stronger instabilities. Although the stripline-coupled 3-tap comb bandpass filter in the front-end circuit exhibits excellent isolation between the bunches, its insertion loss is substantial, exceeding 22 dB. This results in the introduction of the same amount of noise figure, as well as additional noise figure, when

using wideband amplifiers to compensate for this loss. To improve the noise figure, we exchanged the stripline-coupled bandpass filter with the 2-tap cable-combined bandpass filter. We removed the two wideband amplifiers after the bandpass filter and the hybrid circuit, as shown in Fig. 3.

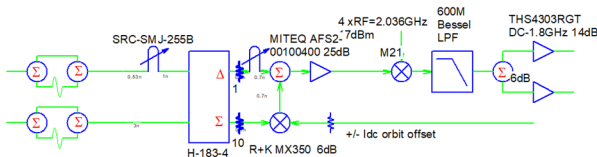

Figure 3: Modified bunch position detection circuit using cable-combined bandpass filters.

The rms counts measured by the ADC of iGp12 have reduced to less than three counts without a beam. Although the final DC amplifier (THS4303) has a relatively higher noise level compared to other low-noise components, its effect on the RMS noise level has not been significant to date (less than 0.5 counts). The system's response and maximum dynamic range, including the iGp12 digital filter, have been measured by changing the bunch COD at the feedback position monitor. The measured response was roughly 1000-1600 counts with the bunch current of 0.4 mA. The total dynamic range of the system with a bunch current of 0.4 mA was estimated to be around  $\pm 1.5$  mm.

After improving the bunch feedback detector at the shutdown time between 2024b (April 2024 to June 2024) and 2024c, we returned the bunch feedback system at the beginning of the 2024c run. We investigated the effect of the feedback gain on luminosity during the 2024c runs. In principle, the FIR filter of the iGp12 has been tuned to be resistive, but not to excite unwanted unstable modes, such as those related to mode coupling. The vertical feedback gain has been tuned to be slightly larger than necessary to suppress the instability. We have successfully suppressed the CBI in both HER and LER, even under the single-beam condition, with nearly the maximum beam current.

In general, the effect of the vertical feedback gain on the luminosity was surely improved. Upon closer examination, it was found that the behaviours of each ring after this modification differed: On LER, similar to the previous runs, exceeding the vertical feedback gain usually increased the vertical beam size and reduced luminosity. On the other hand, too low feedback gain increases the vertical beam size and spoils the luminosity in HER. Within 6 dB of the feedback gain, the decrease in luminosity was not observed in HER.

So far, the side effects of the vertical bunch feedback system in HER have been greatly improved. However, it seems that the improvements in LER are not yet sufficient. Although one fundamental difference may come from the difference in beam energy, we also suspect that other sources, such as noise in the RF reference line, may contribute to this discrepancy.

To synchronize the RF phase during the collision tuning (collision phase scan), we have used the RF reference

signal after the old LLRF (including the analogue phase shifter) in LER. The phase noise of the signal is significantly worse than that of HER and exhibits several sharp peaks in the spectrum, which are related to the down-conversion process. By using the step-recovery pulsar synchronized by the RF and altering the RF signal in the bunch detection system, it was determined that several noise spectrum lines observed during operation originated from the RF reference. In addition, we have checked the noise spectrum of the power supplies in the bunch detection system. Although the noise level in the bunch detection circuit is not significant, we have removed unnecessary DC-DC converters and added noise filters to the DC power lines as much as possible. In the next run (2025c), we plan to prioritize advancing studies on the relationship between feedback noise and luminosity.

## SUMMARY

The bunch-by-bunch feedback system for SuperKEKB rings is functioning well and contributing to the suppression of CBI, which can observe a total beam current of less than 30 mA. This enables the storage of more than 1 A with two filling patterns and a minimum bunch spacing of 4 ns. The feedback noise effect, which enlarges or excites the bunch in the vertical plane, has been observed in both HER and LER. By modifying the bunch detector with an improved noise figure, the rms noise level at the ADC has been significantly reduced.

Even with the improved feedback detector, we still observed the luminosity drop with vertical feedback gain in LER. Although some of the noise will be reduced by modifying the LER RF reference line, we are working to identify the source of the noise and attempt to suppress it by the next planned run in autumn 2025.

The author would like to sincerely thank our colleagues in the SuperKEKB beam instrumentation group for their continued help and valuable suggestions. Discussions with Dr. J. D. Fox of Stanford University and Dr. D. Teytelman of DimTel have been very fruitful. We also thank the SuperKEKB commissioning group for their help in the operation. This work is partly supported by the US-Japan collaboration in High-Energy Physics (R&D for SuperKEKB and the next-generation high-luminosity colliders).

## REFERENCES

- [1] M. Tobiyama and K. Ohmi, "Study of beam size blowup due to transverse bunch feedback noise on e+ e- collider", in *Proc. DIPAC'11*, Hamburg, Germany, May 2011, paper MOPD73, pp. 212-214.
- [2] K. Ohmi *et al.*, "Response of colliding beam-beam system to harmonic excitation due to crab-cavity rf phase modulation", *Phys. Rev. Spec. Top. Accel. Beams*, vol. 14, no. 11, p. 111003, Nov. 2011.  
doi:10.1103/physrevstab.14.111003
- [3] M. Tobiyama, J. W. Flanagan, and A. Drago, "Bunch by bunch feedback systems for SuperKEKB rings", in *Proc. PASJ'16*, Chiba, Japan, Aug. 2016.
- [4] Dimtel Inc., <https://www.dimtel.com/>