

Control of fluid mass center in the Gravity Probe B space mission Dewar

This content has been downloaded from IOPscience. Please scroll down to see the full text.

2015 Class. Quantum Grav. 32 224011

(<http://iopscience.iop.org/0264-9381/32/22/224011>)

View [the table of contents for this issue](#), or go to the [journal homepage](#) for more

Download details:

IP Address: 131.169.4.70

This content was downloaded on 08/01/2016 at 08:40

Please note that [terms and conditions apply](#).

Control of fluid mass center in the Gravity Probe B space mission Dewar

D Frank

Lockheed Martin Corporation, Sunnyvale, CA 94089, USA

E-mail: Dave.Frank@lmco.com

Received 1 January 2015, revised 14 March 2015

Accepted for publication 1 April 2015

Published 17 November 2015



CrossMark

Abstract

Gravity Probe B was a cryogenic, space-based mission that successfully measured two effects predicted by general relativity. The mission required a 2400 l liquid helium Dewar. In this paper we describe the design and performance of the approach taken to control the distribution of the liquid in the Dewar on-orbit. Such an approach may be applied to other spacecraft containing significant liquid mass.

Keywords: fluid dynamics, low gravity fluid, superfluid helium, Gravity Probe B

Introduction

Gravity Probe B (GP-B) was a precision test of Einstein's theory of general relativity [1]. A 2400 l liquid helium Dewar, placed in a 640 km polar orbit about the Earth, provided cooling for the ~ 1.5 year mission. Tight control of the helium mass distribution was required for spacecraft attitude and translation control (ATC), and for minimization of mechanical and gravitational disturbance to the experiment's gyroscope test masses. Control of superfluid helium in low gravity is relevant to those interested in space born instruments studying classical and quantum gravity that contain cooling by superfluid helium. The motion of the fluid is generally important to those experiments.

To perform GP-B, the spacecraft attitude was locked on to a reference star (Guide Star, GS), and the spacecraft translation was defined by the unperturbed orbit of one of the gyroscopes, the drag free sensor. The authority to perform both operations was provided by the Dewar's helium boil off gas, independently allocated to 16 gas thrusters. For well



Content from this work may be used under the terms of the [Creative Commons Attribution 3.0 licence](https://creativecommons.org/licenses/by/3.0/). Any further distribution of this work must maintain attribution to the author(s) and the title of the work, journal citation and DOI.

controlled liquid helium, the ~ 150 mW natural heat rate into the liquid evolved sufficient gas for ATC. Higher gas flow and authority was available by operation of a tank heater, although the resulting reduction in helium lifetime would degrade experiment precision. A sintered titanium porous plug [2] allowed the gas to vent while ensuring the liquid remained within.

The simplest approach to containing the liquid in the tank—allowing it to freely float—was inadequate. The liquid's ill-defined mass distribution and tank wall collisions would cause gravitational disturbances and ATC challenges. Consider the effect of 100 kg of liquid helium with a center-of-mass (CM) offset 10 cm from the drag free. This configuration results in a $\sim 10^{-6}$ g disturbance, as compared with a 10^{-11} g science mission requirement.

To control the liquid, the spacecraft was rolled at fixed rate about the line of sight to the GS. Among many benefits to GP-B [3], this operation symmetrized the liquid helium distribution. Roll tends to cause the helium to move away from the roll axis, distributing itself at the outer diameter of the tank. Critically, roll also causes gravitational disturbance due to CM offset to average to near zero. The on-orbit roll rate was 0.77 rpm or 0.08 rad s^{-1} .

Spacecraft roll requires additional control authority. One might think that for constant roll rate the added authority would be relatively small. This is not always correct. For instance, radial offset of the CM relative to the drag free gyroscope would require authority to force the CM to rotate about the drag free proof mass. To minimize this force, the offset must be small.

Control of fluid CM

Analyses were performed to predict the behavior of helium's CM on-orbit. Although it was found that no baffling was needed to control the fluid after the liquid was rotating, a set of baffles was installed in the tank for initialization. These baffles helped dampen slosh during orbit insertion and assisted in causing the fluid to rotate as the vehicle was spun up. Earlier studies [4–6] evaluated the behavior of the liquid in the GP-B tank, leading to additional analysis [7, 8] that guided the design of final configuration, shown in figure 1.

To guide tank design we assume a near-full Dewar at launch. The space vehicle is spun up to a high roll rate, causing the fluid to take on an axisymmetric profile. The roll rate is then reduced for the remainder of the mission.

Analysis approach

To predict static and dynamic fluid behavior, the primary tool used in the analysis was a computational fluid dynamic called FLOW3D which employs finite difference software developed by Flow Science, Inc. In addition we used Surface Evolver, an interactive software package aimed at the study of surfaces shaped by surface tension. Closed-form solutions of the liquid–vapor interface and scale model tests performed on the ground in 1 g aided in software validation.

Two dimensional and three dimensional simulations of the static shape of the liquid/vapor interface provided the fluid's CM. The dynamic impulse response of the fluid gave slosh amplitudes and damping rates.

Operational constraints

After launch the liquid in a non-rotating vehicle was predicted to have a nonsymmetrical profile as shown in figure 2. To generate an axisymmetric profile, we rotate the spacecraft and

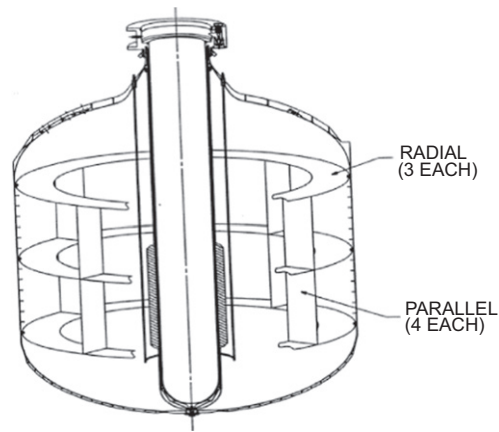

Figure 1. The GP-B baffle configuration.

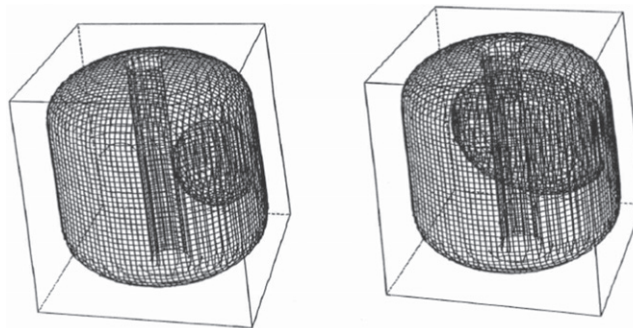

Figure 2. Nonsymmetrical fluid profiles for 95 and 83% fill levels in a non-rotating tank, calculated using FLOW3D. The CM offsets for these two cases are 23 and 82 mm respectively.

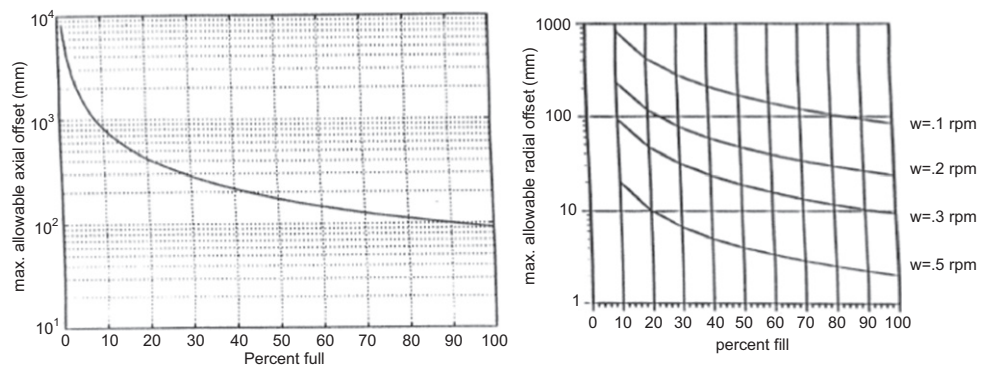

Figure 3. Allowable axial and radial offsets in the liquid helium CM.

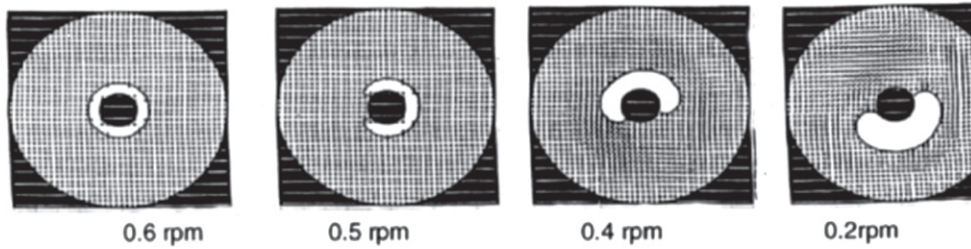

Figure 4. An axisymmetric liquid profile is predicted by FLOW3D at a rotation rate of ~ 0.5 rpm.

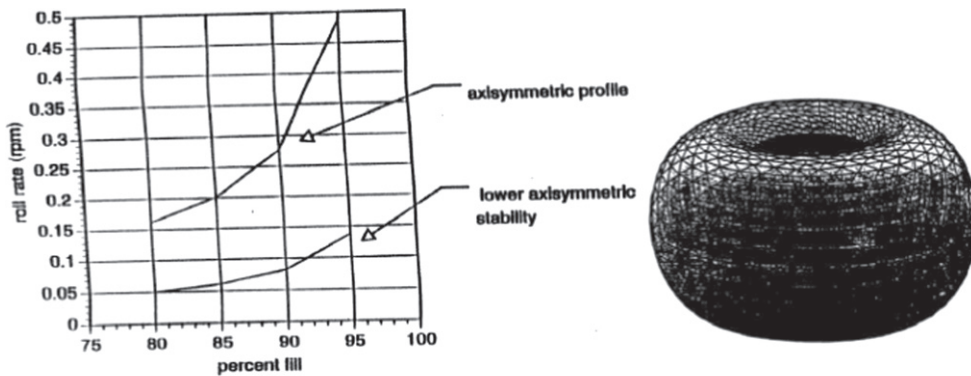

Figure 5. Rotation rate predicted by Surface Evolver to generate an axisymmetric profile and the lower stability limit to maintain it.

fluid, giving a toroidal liquid volume. The roll rate is maintained sufficiently long to get fluid and the tank rotating as a solid body. Thereafter, the rotation rate must be maintained above a lower stability limit or the torus will break up. In addition, the science mission required that the liquid CM shifts be below the maximum allowable axial and radial shown in figure 3.

Rotational rates for axisymmetric profiles

The rotation rate required to generate an axisymmetric profile and the lower rotation rate required to maintain it were calculated with Surface Evolver and FLOW3D for several bubble sizes. The roll rate required to generate the torus profile was determined by starting with a spherical bubble at low rate and increasing it until the bubble wrapped completely around the tank's center post. The rate to maintain the toroidal shape was determined by starting with an axisymmetric bubble at high rotation rate and decreasing it until perturbations of the bubble grew rather than shrunk.

Figure 4 shows results from FLOW3D. A 95% full tank becomes axisymmetric at a rotation rate of ~ 0.5 rpm. Surface Evolver results (figure 5) by Brakke [9] are in good agreement and show that when the tank is $>92\%$ full, an axisymmetric profile is stable at or above 0.1 rpm.

The roll-induced shape of the liquid helium and ullage is disturbed by Earth's gravitational gradient. When the ullage does not span the full length of the tank the gravity gradient

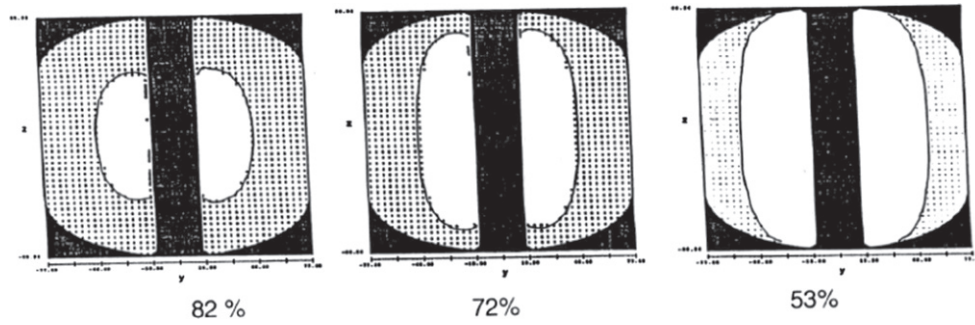

Figure 6. The ullage length increases as the fluid depletes.

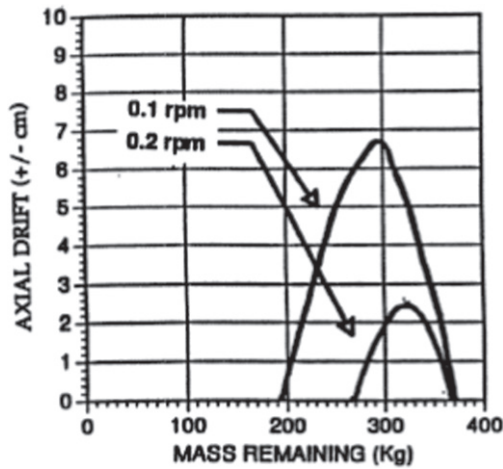

Figure 7. The liquid's CM shift versus mass remaining for two roll rates. A full tank is assumed at launch.

moves the axial location of the ullage, causing the CM to shift. Figure 6 shows the steady state profile of different liquid fill levels at a rotation rate of 0.1 rpm, computed using FLOW3D. At 0.1 rpm, the ullage spans the full length of the tank when it is 53% full. The minimum roll rates needed to flatten the ullage to span the full length of the tank are tabulated in table 1.

A gravity gradient model was incorporated into FLOW3D to determine the axial shift of the ullage and the axial shift of the liquid's CM when the ullage did not span the full height of the tank. Axial CM shifts versus fill level are shown for two rotation rates in figure 7. At 0.1 rpm, the maximum shift is 6.7 cm, occurring when the tank contains ~290 kg or remaining mass or ~80% full

Dynamic performance

The baffle system (see figure 1) dampened fluid motion and assisted in setting the liquid in rotation during the spin-up of the spacecraft. This design does not interfere with an ullage spanning less than the full tank length. Damping characteristics were assessed by subjecting

Table 1. Roll rates required to flatten liquid/vapor interfaces.

Percent fill level	Roll rate (rpm)
95	0.5
83	0.3
72	0.2
53	0.1

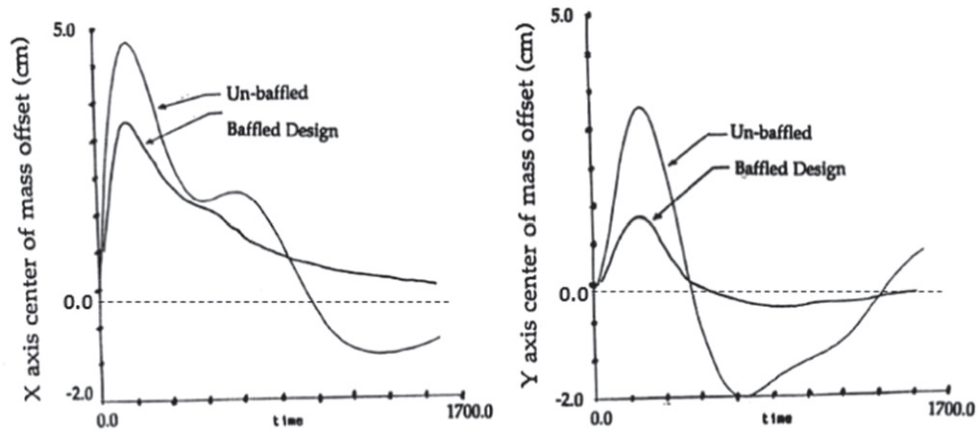
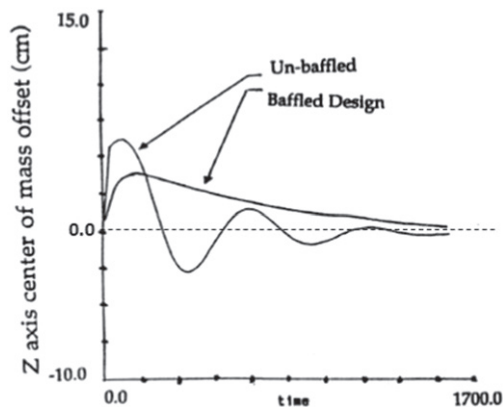
**Figure 8.** Fluid response in X and Y axis to an axial impulse with 60% residual rolling at 0.1 rpm. The baffle configuration provides good damping of the fluid.**Figure 9.** Fluid response in Z axis to a lateral impulse with 60% residual rolling at 0.1 rpm. The baffle configuration provides good damping of the fluid.

the tank to an impulse disturbance of 0.1 ms^{-2} for 10 ms in the lateral or axial direction and calculating fluid displacement and the resultant forces on the tank. Results of these calculations were incorporated into the spacecraft's ATC system model. Figure 8 shows the response to an axial impulse with the tank 60% full rolling at 0.1 rpm. Figure 9 shows the response when subjected to a lateral disturbance for the same fill and roll conditions. In both figures, the fluid CM is displayed in body-fixed coordinates.

Analysis tool validation

To validate the results given in this paper, the software was exercised for test cases in which shapes were known for fluids in low gravity. Predictions were also compared to exact analytical solution of the liquid–vapor interface shape. Models were exercised against the following:

- (1) Test data of a rotating cylinder of ethanol performed by Leslie on a free-falling KC 135 aircraft [10].
- (2) Test data of non-rotating cylinders [11]. Various fluids and diameters were selected in order to get different meniscus shapes. The liquid vapor interface solution used here was by Leslie *et al* [12].
- (3) Test data of scale model ground tests with a storable fluid by Collicott *et al* [13].

The three dimensional FLOW3D model used a $40 \times 40 \times 42$ mesh and was run on a Cray computer. The need for a non-uniform mesh in FLOW3D was investigated. For the current work, a uniform mesh was found to be sufficient, although higher resolution would allow better definition of the high curvature of the meniscus where it intersects the wall. Boundary layer modeling was not required because the fluid and container were in solid body rotation.

Two fluid model considerations

For the GP-B configuration we evaluated [14] the use of single fluid and two-fluid models for treatment of the liquid helium. The arguments below justify use of the single fluid model.

The two-fluid model predicts stationary superfluid and rotating normal fluid for a rotating Dewar. The first observations of rotating helium were performed by Osborne [15], who found that a rotating superfluid behaved as a single fluid with no temperature dependency. The entire fluid volume rotated like a classical fluid. This result was later confirmed by optical measurements by Meservey [16]. These findings are in apparent contradiction with the two fluid theory of superfluid helium. Further, Andronikashvili [17] found a temperature dependence in the density of normal helium in superfluid helium.

Helium rotation can be understood by the presence of vortices in liquid. London was the first to postulate their existence, but experimental observation by Williams and Packard [18] would only come 30 years later. Below a critical velocity the superfluid does not rotate. With only the normal fluid responsible for liquid rotation, the meniscus height is a strong function of the normal fluid density. The expression for determining the critical velocity was verified experimentally by Hess and Fairbank [19], who measured the angular momentum of a cylindrical vessel containing liquid helium as it was cooled through the lambda point. The critical velocity for formation of more than one vortex was measured by Hess [20].

Above the critical velocity, the entire liquid volume rotates, resulting from interaction between the superfluid and the normal fluid through the vortices. For GP-B, the critical velocity is predicted to be $6.0 \times 10^{-7} \text{ rad s}^{-1}$. Such low critical velocity indicates that for all practical situations, the liquid in GP-B's tank can be treated as a single classical fluid.

On-orbit performance

The GP-B spacecraft was launched 20 April 2004 into a 640 km high polar orbit. The liquid helium was well controlled on-orbit, allowing the drag free and attitude control systems to meet mission objectives. Liquid helium was depleted on 29 September 2005.

Spacecraft roll rate immediately following launch was 0.1 rpm. During the initialization of the experiment this rate was adjusted on 15 occasions. A mission maximum 0.9 rpm was commanded on 25 June 2004 to wrap the helium bubble. This rate was maintained for 90 h. The roll rate was reduced to 0.774 rpm or one spacecraft rotation every 77.5 s for taking the science data.

During science data taking an interaction was observed [21] between the liquid helium and the control system. On 29 September 2004, a 4.6 mHz oscillation of increasing amplitude was found in the gyroscope suspension system control efforts in a direction perpendicular to the roll axis. The oscillation was caused by the drag free control system pumping a fluid wave in the Dewar. As the helium was depleted, the frequency slowly decreased to the point where the natural frequency of the wave came into resonance with the drag free control loop which resulted in significant pumping. Transverse acceleration on the gyroscopes peaked at $1.2 \times 10^{-6} \text{ m s}^{-2}$.

In response to the liquid wave, the drag free system was disabled and its controller was retuned slightly to take it out of resonance with the liquid. The wave magnitude damped to acceptable levels. The attenuated wave remained observable for weeks after, pumped lightly by spacecraft ATC thrust.

Conclusion

This paper described the successful control of the distribution of the liquid helium in the GP-B Dewar. A specific Dewar configuration, combined with spacecraft rotation, allowed the ATC to meet mission needs and to adequately reduce the gravitational disturbance on the gyroscopes from the helium.

References

- [1] Everitt C W F *et al* 2011 Gravity Probe B: final results of a space experiment to test general relativity *Phys. Rev. Lett.* **106** 221101
- [2] Wang S *et al* 2015 Porous plug for Gravity Probe B *Class. Quantum Grav.* **32** 224010
- [3] Everitt C W F *et al* 2015 Gravity Probe B cryogenic payload *Class. Quantum Grav.* **32** 224009
- [4] Schafer C and Lowry S 1983 *Mechanics of Liquid Helium in a Partially Filled Rotating Dewar in Low Gravity with Application to Gravity Probe-B* NASA TP2124
- [5] Leslie F, Gans R and Schafer C 1985 *Fluid Surface Behavior in Low Gravity* NASA TP2486
- [6] Hung R, Lee C and Leslie F 1991 Slosh wave excitation in a partially filled rotating tank due to gravity jitters in a microgravity environment *Acta Astronaut.* **25** 523–51
- [7] Frank D, Khan M and Yuan S 1994 Gravity Probe-B fluid management final report *Technical Program Report* LMSC P088355
- [8] Reeve W R 1992 He motion effects on rolling vehicle control authority *Program Engineering Report* ATCS 129
- [9] Brakke K 1993 Stability of torus bubble in rotating tank *Technical Program Report* LMSC P065933
- [10] Leslie F 1985 Measurements of rotating bubble shapes in a low-gravity environment *J. Fluid Mech.* **161** 269–79
- [11] Satterlee H M and Chin J H 1965 Meniscus shape under reduced-gravity conditions *Proc. Fluid Mechanics and Heat Transfer under Low Gravity Symp.* pp 13
- [12] Leslie F *et al* 1985 *Fluid Surface Behavior in Low Gravity* NASA TP-2486
- [13] Collicott S, Bayt R and Courtney S 1994 Ullage bubble stability in the Gravity Probe-B helium tank *Proc. 30th AIAA/ASME/SAE/ASEE Joint Propulsion Conf.* AIAA-94-3026
- [14] Ross G 1994 Dynamics of superfluid helium in low gravity *Ph. D Thesis* Stanford University
- [15] Osborne D V 1950 The rotation of liquid helium II *Proc. Phys. Soc.* **63** 99
- [16] Meservey R 1964 Surface contour of rotating liquid helium II *Phys. Rev.* **133** A1471

-
- [17] Andronikashvili E L 1946 *Zh. Eksp. Theor. Fiz.* **16** 780
Andronikashvili E L 1948 *Zh. Eksp. Theor. Fiz.* **18** 424–150
- [18] Williams G A and Packard R E 1974 Photographs of quantized vortex lines in rotating He II *Phys. Rev. Lett.* **33** 280
- [19] Hess G B and Fairbank W M 1967 Measurements of angular momentum in superfluid helium *Phys. Rev. Lett.* **19** 216
- [20] Hess G B 1967 Angular momentum of superfluid helium in a rotating cylinder *Phys. Rev.* **161** 189
- [21] Bencze W 2013 *Dewar Slosh Mode Observation* private communication