

CAVITY DESIGN FOR A S-BAND PHOTOINJECTOR RF GUN WITH 400 Hz REPETITION RATE

J.W. McKenzie, P.A. Goudket, T.J. Jones, B.L. Militsyn, STFC/DL/ASTeC, UK
 L.S. Cowie, STFC/DL/ASTeC & Lancaster University, Cockcroft Institute, UK
 G. Burt, Lancaster University, Cockcroft Institute, UK
 V.V. Paramonov, INR of RAS, Moscow, Russia

Abstract

As part of the design of CLARA (Compact Linear Accelerator for Research and Applications), the proposed UK FEL test facility at Daresbury Laboratory, a high repetition rate S-band photoinjector RF gun is being developed. This gun will be able to operate at up to 400 Hz repetition rate in single bunch mode. We present the initial cavity design, including its optimisation for the beam dynamics of CLARA. We also present the initial cooling design for the cavity which will enable the high repetition rates to be achieved.

INTRODUCTION

A 1.5 cell, 2.9985 GHz photocathode RF gun, shown in Fig. 1, has been designed at Daresbury Laboratory to deliver high brightness electron beams as the injector for the CLARA FEL test facility [1]. The gun will initially be tested on VELA [2] which contains a suite of diagnostics to fully characterise the 6D phase space of the emitted electron beam. The gun will operate in two modes – (1) 400 Hz with a field of 100 MV/m, and (2) 100 Hz with a field of 120 MV/m.

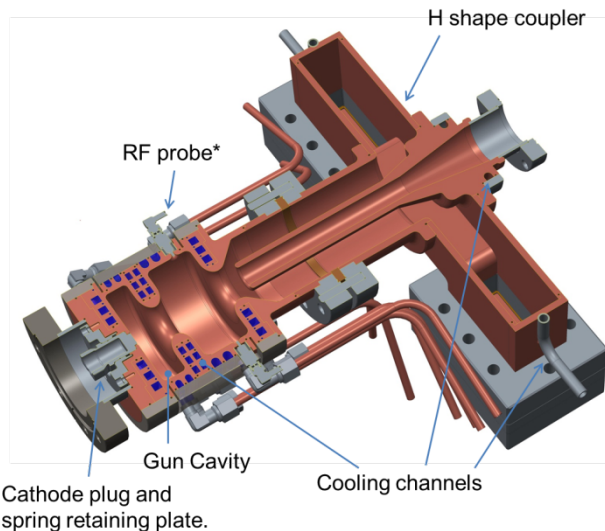

Figure 1: Overview of the gun design.

The gun will be equipped with a photocathode exchange system to accept plugs of the INFN/DESY type [3]. Such a system allows for cathode changeover without breaking the cavity vacuum, and enables different metal and alkali photocathodes to be tested. The gun cavity will be surrounded by a solenoid for emittance compensation and transverse focussing, and a bucking

coil behind the cavity to cancel the magnetic field on the cathode plane.

To reach the 400 Hz repetition rate, a large number of cooling channels surround the cavity, informed by computational fluid dynamics of the completed cavity and coupler RF model. An RF probe is included for active monitoring and feedback.

CAVITY DESIGN

A coaxial coupler was chosen over side-coupling in order to preserve symmetry of the fields in the cavity and to minimise the effects of the dipole mode. This also allows a solenoid to be placed around the cavity itself, rather than after, which is desirable from a beam dynamics standpoint.

The cells are cylindrical with rounded edges to allow for a better distribution of the peak field and, as result, heat load. Effective cooling will be required due to the high average power, calculated as 6.8 kW, and will be provided by water channels cut into the bulk of the cavity. The cathode is inserted through a plug in the back-plate of the first cell.

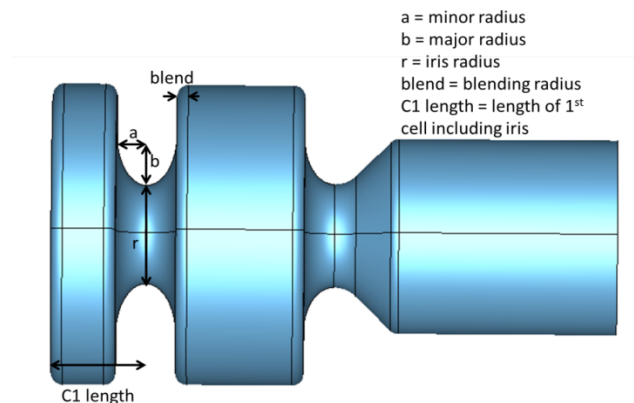

Figure 2: Parameterised 2D gun cavity model.

For the purpose of RF and beam dynamics optimisation, the cavity was parameterised as shown in Figure 2 and modelled in Superfish via a custom Mathematica interface. This allowed each parameter to be varied individually, and a script automatically adjusted the radii of both cells to compensate for any changes in frequency or field flatness. Overall frequency will be set with operational water temperature at a rate of 50 kHz/deg, typical for S-band cavities. Tuning range is therefore limited by reasonable temperature ranges of about 10 K, leading to a 500 kHz tolerance in frequency.

First Cell Length

The parameter which has the largest effect on the beam dynamics is the first cell length. For optimisation the cell length was varied in Superfish and on-axis electric field distribution exported into ASTRA to simulate the beam dynamics. The beam, generated with a 76 fs rms laser pulse, was tracked from the photocathode through to the exit of the first linac module of CLARA as detailed in [1] and the beamline components optimised to give the minimum transverse emittance for each case.

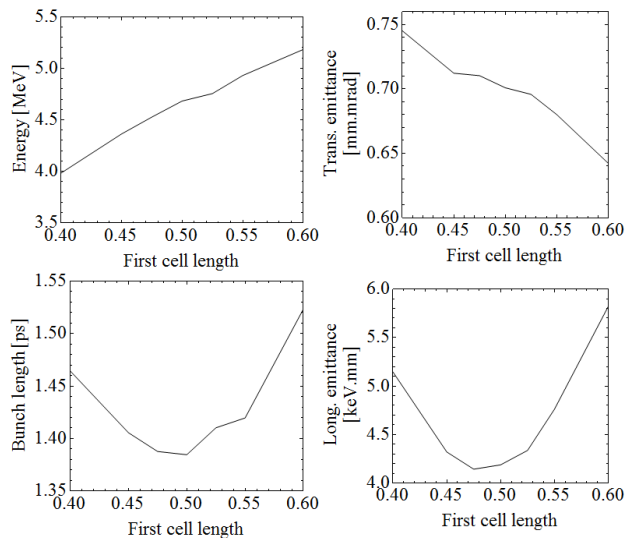

Figure 3: Beam parameters at the exit of the CLARA first linac for different gun first cell lengths.

Figure 3 shows the results of the cell length scan for a 250 pC bunch with a peak on-axis electric field of each cavity of 120 MV/m. Scans were also carried out at bunch charges of 25 and 100 pC, and electric field of 100 MV/m. The first cell length is given as a fraction of the full cell length. Increasing the cell length increases the final energy of the gun and reduces the transverse emittance.

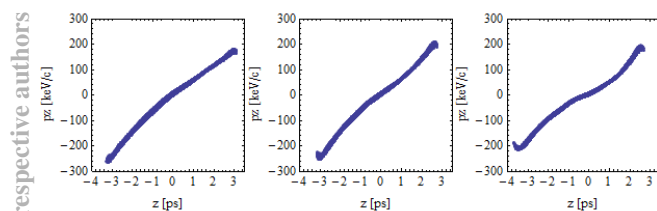

Figure 4: Longitudinal phase space at the exit of the CLARA first linac for gun first cell lengths of 0.4, 0.5, and 0.6 of the second cell (left to right).

However, looking at the longitudinal properties, there is an optimum cell length for minimising bunch length and longitudinal emittance. Figure 4 shows that for longer cell lengths there is more curvature in the longitudinal phase space of the beam – this makes the beam more difficult to manipulate downstream to provide the required bunch length for the FEL. Given that there is no requirement to push for higher gun energy and the transverse emittance

in all cases meets the requirements for the CLARA FEL, a first cell length of 0.5 times that of the full cell provides optimum longitudinal beam properties.

2D Cavity Shape Design

Once the cell length was determined, the other 2D shape parameters, shown in Fig. 2, were optimised. The iris radius, r , was chosen as a trade-off between R/Q and mode separation. The iris profile was chosen to be elliptical to minimise the maximum electric field. The ellipse minor radius, a , was fixed to 8 mm to give room for the cooling channels the ellipse major radius, b , and iris radius, r , optimised to give maximum R/Q for a minimum mode separation of 20 MHz.

3D Cavity Modelling

3D modelling of the gun cavity was carried out in CST to verify the 2D model and include additional elements. An RF probe is included in the second cell to monitor the fields with a second probe opposite for symmetry reasons. The presence of these probes places constraints on the cooling channels surrounding the cavity. Of greater concern is that the probe aperture concentrates wall currents, thus leads to large local heating. Though the probe aperture has been given a 3 mm blend, this region has the highest magnetic fields, as shown in Fig. 5. To reduce this, further optimisation in the probe vicinity is required.

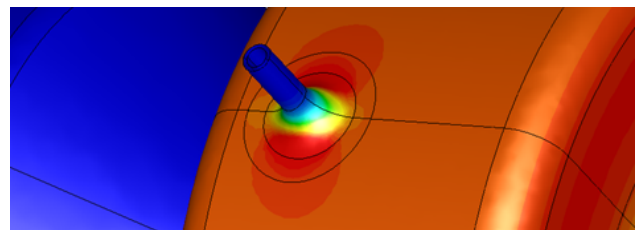

Figure 5: Magnetic field distribution around the RF probe.

Photocathodes will be exchanged through the back-plane of the cavity through a 10 mm diameter cathode plug. This perturbs the electric fields locally (as can be seen in Fig. 6) and can give rise to a $< 4\%$ field enhancement on the cathode. Figures 6 and 7 show the electric and magnetic field distributions of the cavity calculated using a frequency domain solver.

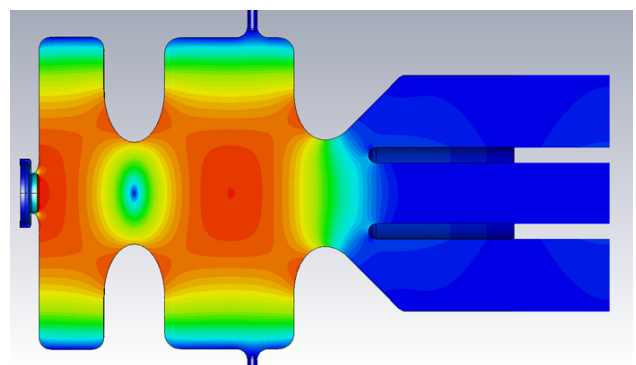

Figure 6: Electric field distribution.

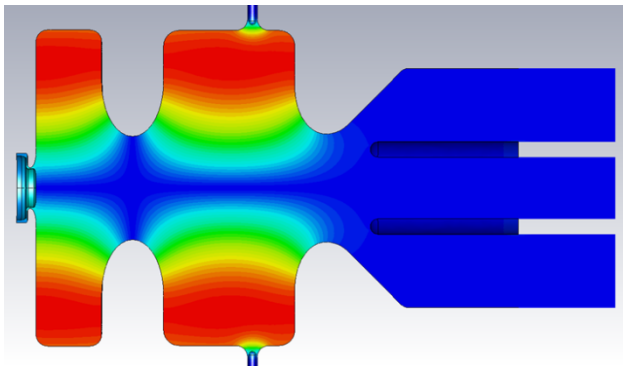

Figure 7: Magnetic field distribution.

COUPLER DESIGN

Studies carried out on single-feed asymmetric designs show that they lead to a TE₁₁ dipole mode that can propagate to the cavity. Due to the aperture size required for the laser, the cut-off frequency of the TE₁₁ mode in the coax section was below 3 GHz, resulting in up to 16% of the input power being transmitted to the TE₁₁ mode at the doorknob. While the coaxial length can be modified to cancel this out it still leads to a standing wave in the coupler which could cause a 50 kV transverse kick to the beam and cause asymmetric coupler and cavity heating, coupler mismatch and multipactor conditions. In order to allay that risk, it was decided to use a dual-feed system whereby the RF arrives to the cavity symmetrically.

A capacitive match at the doorknob is the solution commonly chosen for similar designs. However, it is a major risk in terms of multipactor and breakdown due to its geometry. An inductive iris would allow matching while removing the additional vulnerabilities presented by the capacitive coupling. The inductive iris is, however, not tuneable, and reduces vacuum conductivity of the gun.

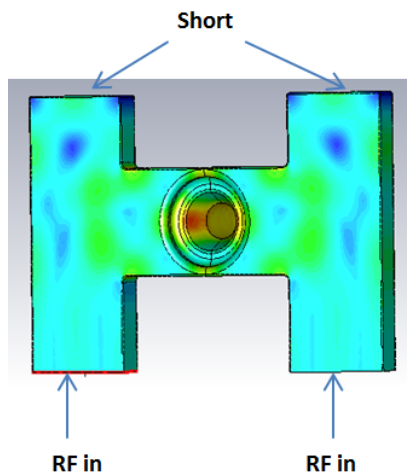

Figure 8: Electrical fields in the H-feed coupler.

In order to allow the coupler to be tuned to achieve the best possible match, we propose an alternative H-feed design, shown in Fig. 8. Movable shorts allow fine tuning of each arm separately, allowing the best possible

compensation of phase errors in the two arms as well as the overall match of the transition. The shorts also give good access for pumping should this be required.

COOLING DESIGN

The cooling design of the cavity was based on that of the Diamond Light Source S-band RF gun [4]. Multiple channels surround the cavity as shown in Fig. 9. The original design was modified to accommodate the RF probes and different cavity geometry.

Surface magnetic fields were taken from the 3D CST RF model and heat flux calculated for each region. At a gradient of 100 MV/m at 400 Hz repetition rate, this gives a total average heat load of 6.8 kW. Computational fluid dynamics simulations were then carried out with ANSYS. With a water temperature of 40°C and a 0.3 Bar pressure drop across all channels, the average temperature increase is 16°C, increasing to 17°C on the iris walls and a peak of 22°C on the RF probe blend, as shown in Fig. 9.

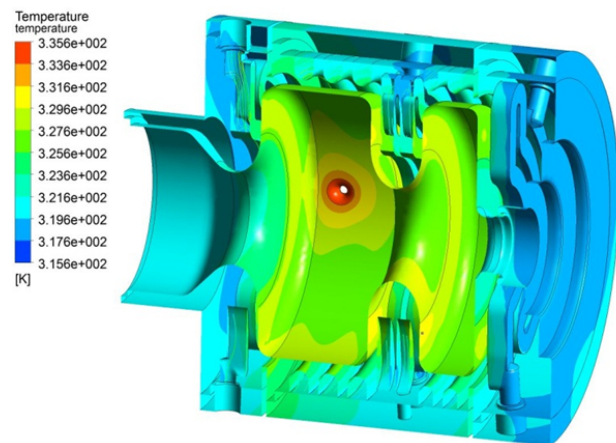

Figure 9: Temperature increases with the proposed cooling system with the gun operating at 100 MV/m at a 400 Hz repetition rate.

CONCLUSIONS

A 1.5 cell S-band RF gun cavity equipped with a novel H-feed coaxial coupler has been designed with cavity properties optimised to provide beam for the CLARA FEL test facility and operate at repetition rates up to 400 Hz.

REFERENCES

- [1] J. A. Clarke et al., "CLARA Conceptual Design Report", 2014 JINST 9 T05001.
- [2] P. McIntosh et al., "VELA: A New Accelerator Technology Development Platform for Industry", Proc. IPAC'14, Dresden, Germany, WEPME083.
- [3] S. Schreiber et al., Proc. of PAC'03, (2003) 2071-2073, see also <http://wwwlasa.mi.infn.it/ttfcathodes>
- [4] J.-H. Han et al., "S-band Photocathode Gun with a 1 kHz Repetition Rate", proceedings of LINAC2010, THP104.