

PULSED-WIRE MEASUREMENTS FOR INSERTION DEVICES

D'Audney, S. Stellingwerff, S.G. Biedron, S.V. Milton
 Colorado State University, Fort Collins, CO, 80521 USA

Abstract

The performance of a Free-Electron Laser (FEL) depends in part on the integrity of the magnetic field in the undulator. Correcting magnetic field imperfections within the undulator is important for optimal FEL gain. Thus, the magnetic field must be properly mapped. A pulsed wire method is a quality method to achieve this when a traditional Hall device cannot be used. The pulsed-wire method works by sending a square current pulse through the wire, which will induce an interaction with the magnetic field due to the Lorentz force. This force causes the wire to be displaced, and this displacement travels along the wire in both directions as an acoustic wave. Measurement of the displacement in the wire over time using a motion detector yields the first or second integrals of the magnetic field. Dispersive effects in the wire are corrected using algorithms resulting in higher accuracy results. Once the fields are known, magnetic shims can be placed where any corrections are needed.

INTRODUCTION

The performance of a Free-Electron Laser (FEL) depends in part on the quality of the magnetic field in the undulator. The magnetic field on the axis of the undulator is transverse and sinusoidally varying due to the periodic sequence of dipoles. The length of these periods, and the electron beam energy, determine the wavelength of the radiation that will be generated. When a relativistic electron bunch from the particle accelerator is injected into the undulator, the static magnetic fields create transverse oscillations in the particles' trajectory. These oscillations cause the electrons to emit energy. The ideal trajectory of a relativistic electron bunch inserted along the axis is sinusoidal in the plane of oscillation. Phase errors are produced when the path of the electron is not the ideal sinusoidal trajectory, due to imperfections in the magnetic field. The dipole magnets should compensate each other to limit phase errors and diminish the divergence of the electron bunch to the optical beam. In the case of an FEL, phase errors in the electron trajectory lead to a reduction in electron beam bunching. This effect causes a reduction in the energy transfer from the e-beam to the optical field and hence, reduces FEL gain [1,2]. Thus, the magnetic field must be mapped and tuned to a level acceptable to efficient FEL operation. A pulsed-wire method can be used to determine the profile of the magnetic field.

Traditionally, the fields within these devices have been measured with high accuracy using a Gauss meter or Hall probe; however, with the advent of more complex and superconducting undulators these types of probe systems

may not always be a viable option. Topographies such as narrow undulator gaps or cryogenic environments in superconducting undulators restrict measurement access. A pulsed wire method is an attractive option to map the magnetic field in a noninvasive manner [3-5]. In our particular case, the undulator has large metal spacers to keep the undulator gap steady. These spacers make it a solid candidate for a pulsed wire experiment.

The pulsed-wire method described here overcomes several effects that have previously limited the method's accuracy in characterizing the magnetic field in an undulator. The principal component of this technique is a thin current-carrying wire, specifically a 75-um Copper Beryllium wire which is used to simulate both the velocity and trajectory of a charged particle within the undulator. The Lorentz force acting upon the current within the wire causes movement in the wire, and this force is proportional to the local magnetic field acting on it. The resultant motion then propagates as a wave along the length of the wire. The displacement of the wire is measured by an optical detector and then processed using MATLAB algorithms. A schematic of a basic pulsed-wire method is shown in Fig. 1. To establish an absolute value for the pulsed-wire measurements being done, a characterized reference magnetic field is required. This field is applied along the wire external to the undulator fields and used to calibrate the measured undulator fields.

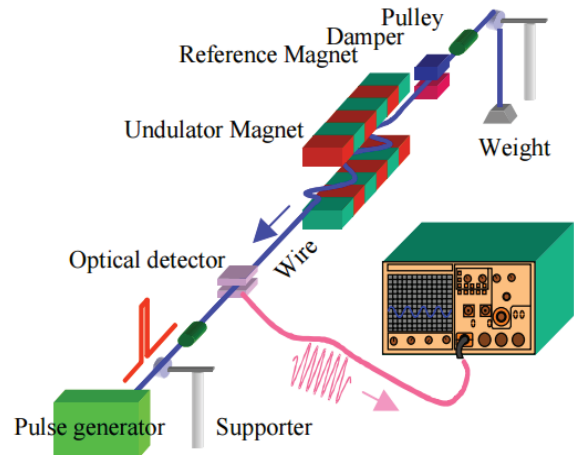

Figure 1: Simplified pulsed wire setup [6].

In the past, dispersive and finite pulse width effects within the wire have had undesirable consequences on the measured field profile. Recently developed algorithms compensate for these effects and increase the accuracy of the measurements [6]. Magnet imperfections can be easily corrected by using small magnetic shims once the field is characterized [2, 7].

The undulator under test is a hybrid type Sm_1Co_5 permanent magnet device, containing 50 periods each with a length of 25mm [8]. The undulator was designed with curved poles to utilize parabolic pole focusing and has a peak field of 0.61T.

THEORY

A pulsed wire method can be used to determine the profile of the magnetic field. This is achieved by sending a square current pulse through a tensioned wire, inducing an interaction with the magnetic field. The electrical pulse causes displacement of the wire and the direction of displacement depends on the polarity of the magnetic field, based on the Lorentz force. The direction and strength of the force acting on the current-carrying wire is defined as:

$$\vec{F} = q(\vec{v} \times \vec{B}) \quad (1)$$

Thus, the amount of wire displacement is proportional to the magnitude of the local transverse magnetic field component, \vec{B} , as well as the charge in the wire, q . Since the wire is tensioned, the wire will not stay displaced after the pulse, creating an acoustic wave traveling out of the undulator along the wire in both directions.

The acoustic wave speed is partially determined by the amount of tension on the wire. The first and second field integrals can be determined by introducing short (microseconds) and long (milliseconds) pulses respectively. Dependent upon the length of the current pulse, the measurement of the displacement using a motion detector yields the first or second integrals of the magnetic field over time/position. The length of the long pulse as well as the wire is based on the length of the undulator. The wire must be long enough so that reflections from the end points of the setup do not interfere with the signal being measured. For the long pulse to be effective, the pulse must be “on” long enough for the acoustic signal to completely pass the detector.

To find the wave speed of the signal within the wire, one must take two measurements that are displaced from each other by some distance dz . The formula used is [6]:

$$\bar{u}_s^*(\omega) \bar{u}_{s\Delta z}(\omega) = |G(\omega)|^2 e^{i\kappa\Delta z} \quad (2)$$

where $\bar{u}_s(\omega)$ is the wire displacement, κ is the wavenumber, and $G(\omega)$ is a magnitude proportional to the magnetic field. The phase of this equation can be described by $\phi = \kappa\Delta z$. Thus, the wave speed can be described as:

$$c = \frac{\omega\Delta z}{\phi} \quad (3)$$

SETUP

The pulsed-wire technique requires a few key elements to function. These include a pulse generator, laser and

photo-detector system, reference magnet, pulley and weight, and a way to accurately position the wire. This section explores the various designs and equipment used as well as the procedures involved. Much of the design was built from scratch and fabricated in-house.

Obviously an important part of the pulsed-wire method is the generation of the actual pulse delivered to the wire. The circuit needs to provide enough current amplitude for the photodetector and oscilloscope to detect the displacement of the wire well over noise level. It was found that a pulse with over 1A of current would be sufficient for the CSU undulator. An in-house designed and constructed pulse generator triggers a high voltage circuit to supply the required pulse to the wire.

The optical detection section consists of a 635 nm fiber laser used with an amplified Si Photodetector. A thin, 40 um, slit is placed over the photodetector using a precision cage rotation stage and is aligned parallel to the wire's axis. The wire is placed between the collimated laser and the slit and is positioned such that half the slit is covered by the wire. By covering half the slit with the wire, clipping of the signal can be greatly reduced. The detector sends the displacement of the wire as a voltage to the oscilloscope.

Precise positioning of the wire within the undulator is a major requirement of the pulsed-wire method particularly in our case with the use of a parabolic pole face undulator. To accurately simulate the electron beam, the wire must be precisely in the magnetic center of the undulator. Measurements at different places within the undulator show this effect as seen in Fig. 2.

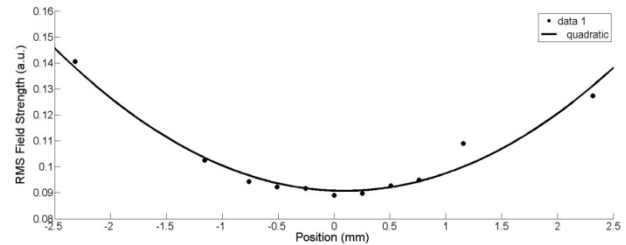

Figure 2: Peak magnetic field inside undulator gap.

The affects of the pulley and weight system in this setup are important to discuss as well. The main purpose of the weight and pulley is to provide a well known tension on the wire such that the wave velocities are reasonable for the given setup conditions. The pulley and weight have addition functions in the pulsed-wire setup. The tensioned wire and pulley dampen the reflections of the pulse within the wire. One pulse must dissipate before the next pulse can be introduced. Faster dissipations of the reflections leads to a higher possible repetition rate of the pulse. The tension on the wire also assists with dispersion issues. Increased wire tension reduces dispersive effects. Thus, the wire tension was increased from an initial 0.431 N to 2 N. The effects from increased weight can be seen in Fig. 3.

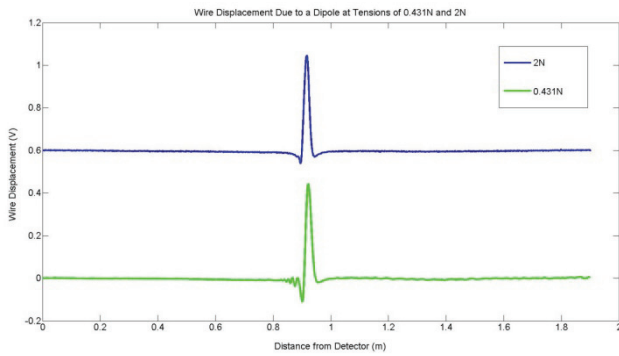

Figure 3: Signal difference between 0.431N and 2N tension.

RESULTS

Dispersive effects in the wire were measured. The wave speed in the wire is a function of frequency and follows the Euler-Bernoulli principles. A Matlab program was developed to measure the wave speed in the pulsed wire method. The results can be seen in Fig. 4 and is compared to the theoretical value of the wave speed.

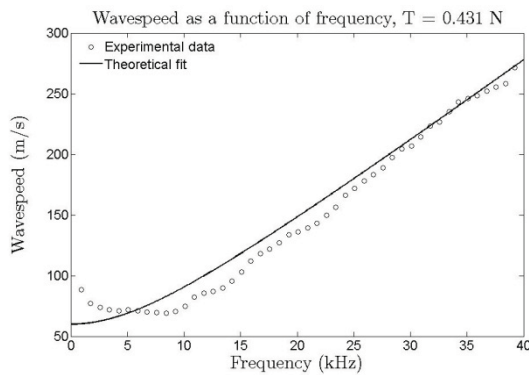

Figure 4: Wave speed as a function of frequency.

Using this data for wave speed, the dispersion within the wire can be corrected using a MATLAB algorithm. The corrected field profile of the reference magnet can therefore be found. Once the first integral of the magnetic field is dispersion corrected, it can be compared to the integral of the Hall probe data.

The corrected signal and associated magnetic field of the undulator and dipole is shown in Fig. 5.

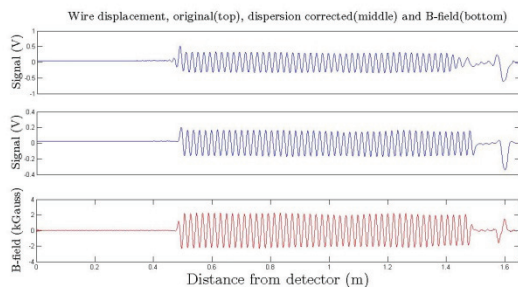

Figure 5: Undulator and dipole signal (Dispersive, nondispersive, and associated magnetic field).

CONCLUSIONS

A pulsed wire method has been developed and used to characterize the magnetic field of CSU’s undulator. A reference magnet was built and mapped thoroughly using a Hall probe. Measurements of the reference magnet were done with the pulsed wire technique for comparison. The geometric and magnetic centers of the undulator have been found and measurements were taken at the latter. A dispersion correction algorithm was implemented in Matlab and applied to both the reference magnet and undulator field respectively. For future work, the phase error needs to be determined and then the poles can be corrected using small magnetic shims. Results are reproducible and the method can be used for many different types of magnets in the future for ultra-fast field characterization.

REFERENCES

- [1] Gehlot, M., Mishra, G., “An overview of the undulator field measurement studies at insertion device lab, DAVV” J. Phys.: Conf. Ser. 365 (2012) 012052.
- [2] Verschuur, J.W.J., Warren, R.W., “Tuning and characterization of Twente wiggler”, Nucl. Instr. & Meth. A 375 (1996) 508-510 Warren, R.W. Nucl. Instr. & Meth. in Phys. Res. A 272 (1988) 257
- [3] Chavanne, M. Hahn, R. Kersevan, C.A. Kitegi, C. Penel, F. Revol, ESRF, Proceedings of EPAC 08, WEPC105, Genoa, Italy, 2008, p. 2243.
- [4] S. Popovich, 9th International Magnetic measurement workshop, CEA/Saclay, June, 1995.
- [5] Vall’au, M., Benabderahmane, C., “ Measurements of soleil insertion devices using pulsed wire method”, Proceedings of IPAC2011, San Sebastián, Spain, 2011 Lake Shore Cryotronics Inc., Transverse Probes — Specifications, retrieved December 2014 from: <http://www.lakeshore.com/products/hall-probes/transverse-probes/pages/Specifications.aspx>
- [6] Fan, T. C., Lin, F.Y. et al., “Pulsed wire magnetic field measurements on undulator U10P”, Proceedings of PAC2001, Chicago, USA, 2001, p. 2775-2777.
- [7] Arbelaez, D., Wilks T. et al., “A dispersion and pulse width correction algorithm for the pulsed wire method”, Nucl. Instr. & Meth. in Phys. Res. A 716 (2013) 62-70. Verschuur, J.W.J., Warren, R.W., Nucl. Instr. & Meth. A 375 (1996) 508-510.
- [8] Ernst, G.J. et. al., “The ‘TEUFEL’ project”, W.J., Nucl. Instr. & Meth. A 318 (1992) 847-852.