

Streaming Infrastructure for Frequency Multiplexed Sensors

Sarah Marmolejos, Wake Forest University – URA Women in STEM Intern

FERMILAB-POSTER-23-168-STUDENT

Introduction

Fermilab's Quantum and Astrophysics Systems Department had developed a firmware that could be used to excite many different MKID's (microwave kinetic inductors) using a single Radio Frequency Feed Line. This firmware allows the integration of up to 4,000 channels on a single FPGA (Field Programmable Gate Array). Many of the projects that utilize this firmware would benefit from having the ability to stream data from a board to a computer continuously.

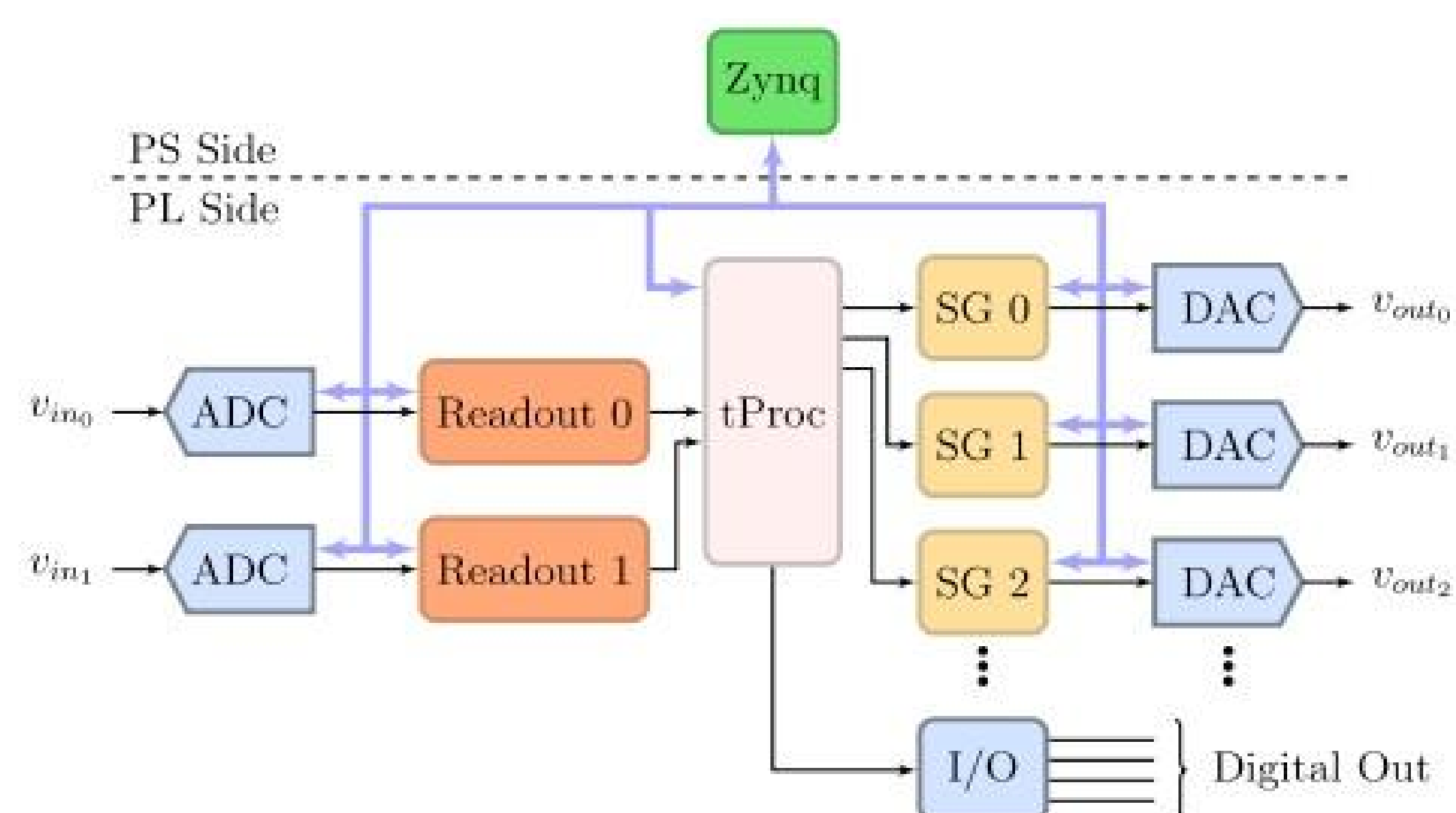

Figure 1: This block diagram for the QICK firmware shows how information is passed between the Radio Frequency (RF) blocks and the firmware. The firmware consists of the signal generator (SG), timed-processor (tProc), and Readout blocks. The RF blocks include the ADC (analog to digital), DAC (digital to analog), and digital output.

Methods

Field Programmable Gate Arrays (FPGA's)

FPGAs are integrated circuits that have a programmable fabric made up of logic blocks. Some can make use of higher-level programming by including additional interface functions and components.

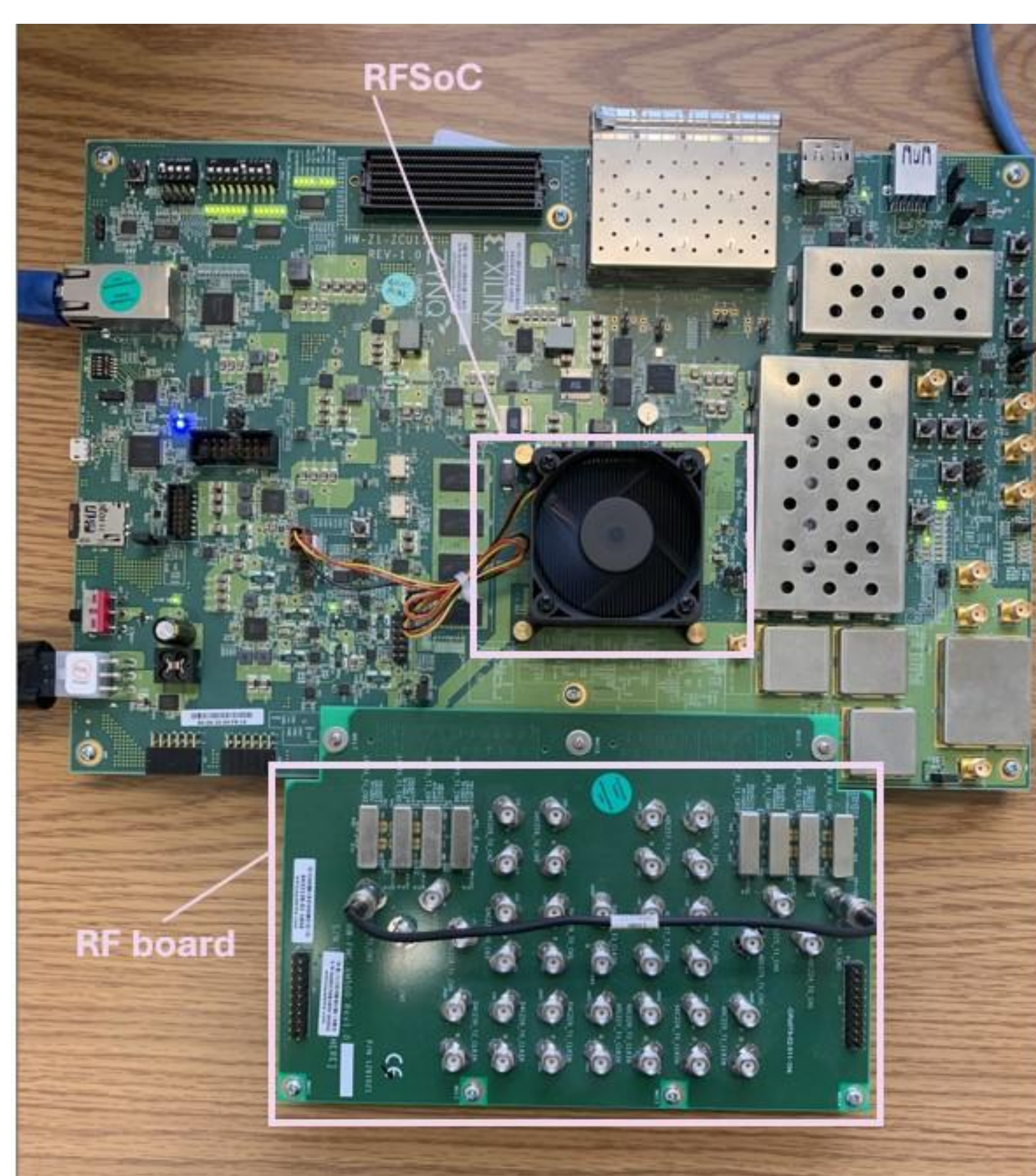

Figure 2: Shown above is the ZCU111 board. Highlighted are the RFSoc (software, firmware, RF, and processor components) and the RF board.

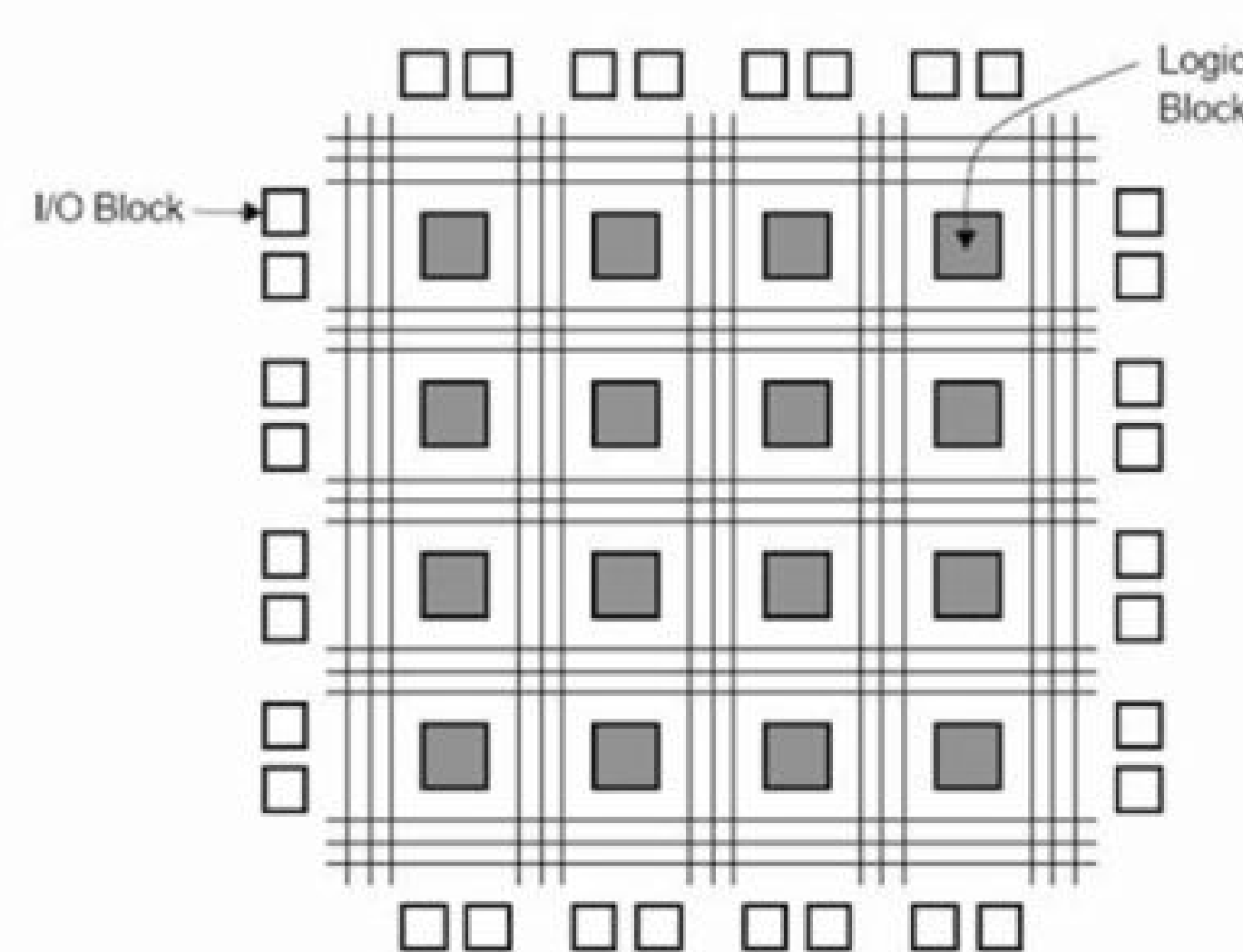

Figure 3: The diagram shows a basic layout for the lower level programming of an FPGA [2].

User Datagram Protocol (UDP)

Figure 4: This project mostly involved the higher level programming of the FPGA using a Jupyter notebooks environment, and the ubuntu linux operating system.

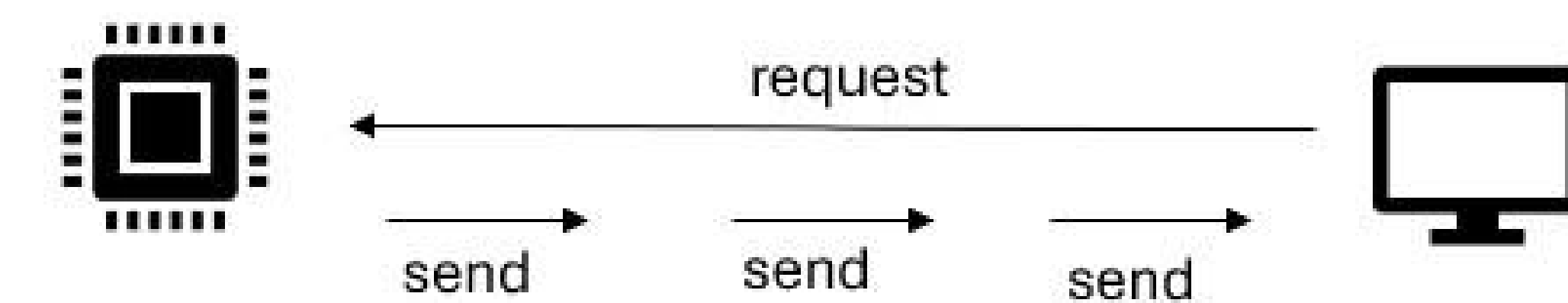
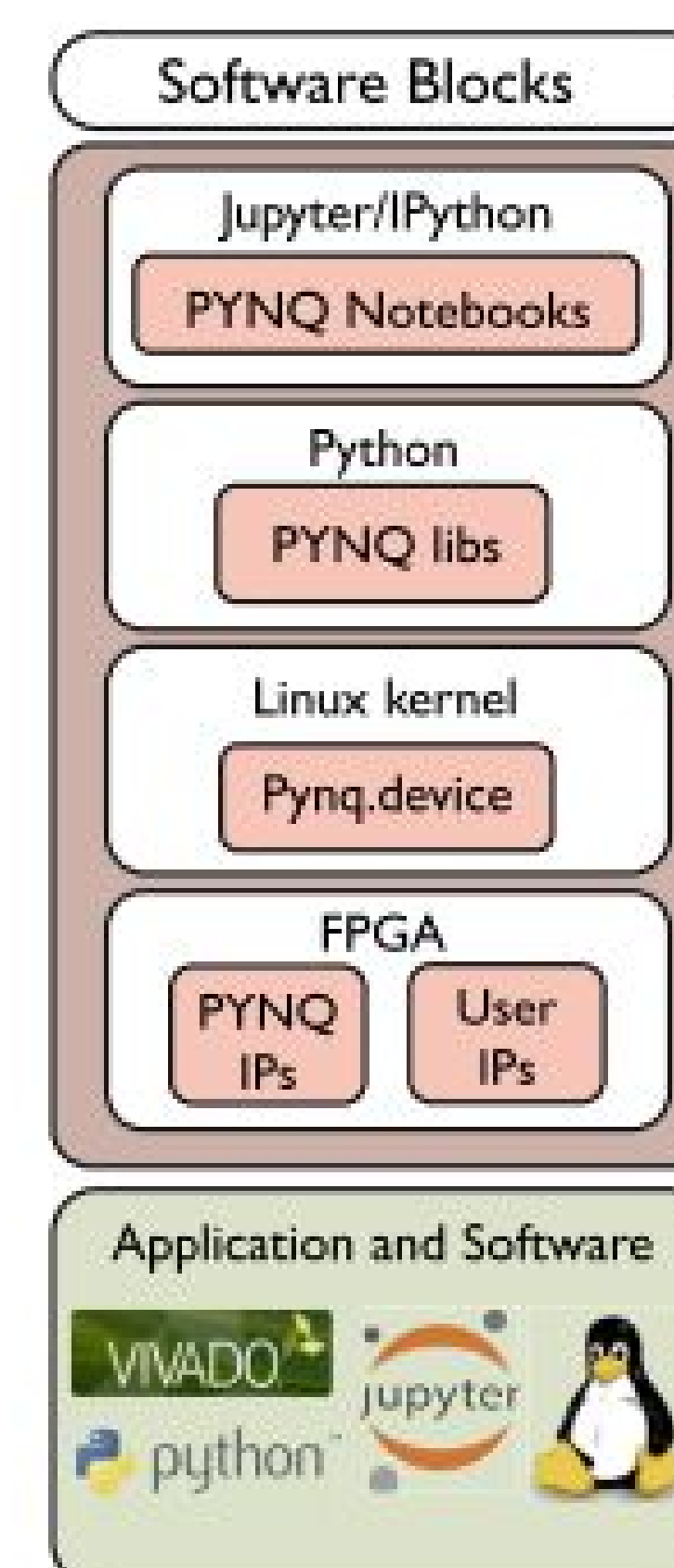
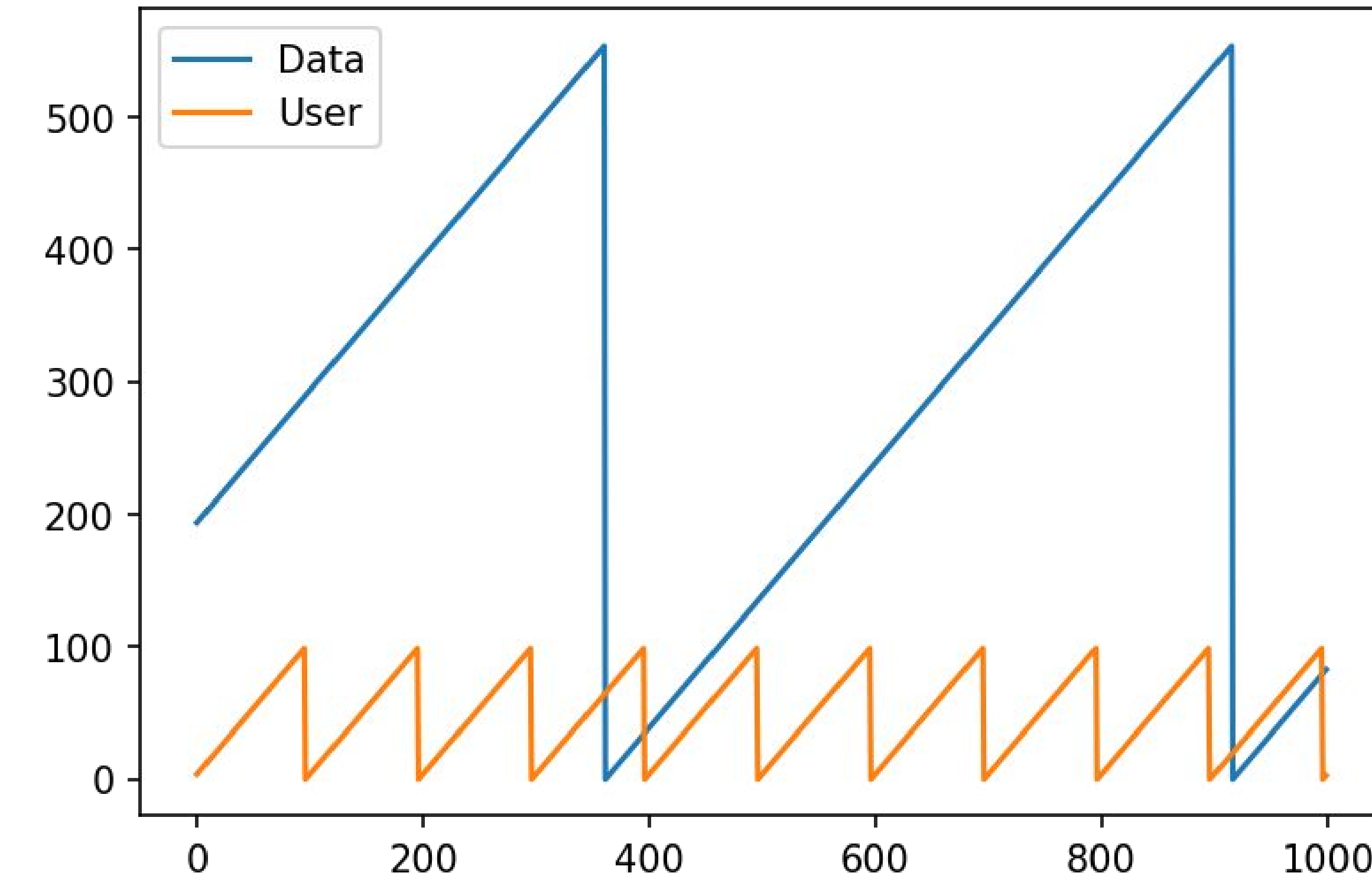

Figure 5: This diagram demonstrates how UDP is carried out between devices. After an initial request is sent from the computer, the FPGA continuously sends back information.

UDP is a type of communication protocol that doesn't require any handshaking when transferring data. This would allow almost instant communication between devices that use it. Using a python library called Pyro, we were able to program an FPGA to send objects to a laptop over the server.

Figure 6: This plot was produced after programming the ZCU111 to produce data. However, the board had not been loaded with the QICK firmware. The board is only plotting points from the counter, which resets to zero after reaching a set limit.



Conclusions and Future Work

During this process we had been able to successfully establish a constant connection between an FPGA and a computer. The next step is to send data over a server with a board that is using the firmware mentioned in the introduction to simulate an actual experiment.

Acknowledgements

I would like to thank my supervisor Leandro Stefanazzi, as well as Sho Uemura, for their guidance throughout this project.

References

- [1] L. Stefanazzi *et al.*, "The QICK (Quantum Instrumentation Control Kit): Readout and control for qubits and detectors," *Review of Scientific Instruments*, vol. 93, no. 4, p. 044709, Apr. 2022, doi: [10.1063/5.0076249](https://doi.org/10.1063/5.0076249).
- [2] A.O. El-Rayis *et al.*, "Reconfigurable architectures for the next generation of mobile device telecommunications systems," Nov. 2014.