



PAPER

Work costs and operating regimes for different manners of system-reservoir interactions via collision model

OPEN ACCESS

RECEIVED
8 January 2022REVISED
9 April 2022ACCEPTED FOR PUBLICATION
25 April 2022PUBLISHED
12 May 2022

Original content from
this work may be used
under the terms of the
[Creative Commons
Attribution 4.0 licence](#).

Any further distribution
of this work must
maintain attribution to
the author(s) and the
title of the work, journal
citation and DOI.

Ying Wang, Zhong-Xiao Man* , Ying-Jie Zhang  and Yun-Jie Xia

School of Physics and Physical Engineering, Shandong Provincial Key Laboratory of Laser Polarization and Information Technology, Qufu Normal University, 273165, Qufu, People's Republic of China

* Author to whom any correspondence should be addressed.

E-mail: zxman@qfnu.edu.cn**Keywords:** collision model, quantum thermodynamics, quantum thermal machine, work cost

Abstract

In this work, we study effects of different types of system-reservoir interactions on work costs and operating regimes of thermal machines by considering a quantum system consisting of two subsystems embedded in both independent and common reservoirs. The model allows us to make a contrast between three configurations of system-reservoir interactions, namely, the three-body one, the two-body one with and without intrasystem interaction between two subsystems. After establishing general formulations of thermodynamics quantities, we derive specific forms of heat and work with respect to these three configurations based on a model with two coupled qubits. It is shown that both the amount and sign of work are closely related to ways of system-reservoir interactions, by which six types of operating regimes of machines are constructed for a given setting. We find that different modes of system-reservoir interactions lead to different numbers of operating regimes of machines on the one hand, and on the other hand machines of the same kinds can appear in different scenarios of system-reservoir interactions, but which one is superior over others relies on intervals of parameters. A possible implementation of the setup based on the platform of circuit quantum electrodynamics is discussed briefly. We then generalize the bipartite model to multipartite case and derive the corresponding formulations of thermodynamics quantities. Our results indicate that interacting manners of system-reservoir play an important role in modifying thermodynamics process and can thus be utilized in designing quantum thermal machines with requisite functions.

1. Introduction

Recent years witness growing interest in the study of quantum thermodynamics (QT) [1, 2] which aims to extend the classical thermodynamics laws to quantum domain and seeks to design thermal machines by virtue of quantum resources. The exciting progresses in quantum information technology also promote ones to explore how quantum effects influence thermodynamics process and to pursue genuine quantum superiorities in quantum thermal machines over their classical counterparts [3–6].

Since the work substance in QT is open quantum system, the popular approach to characterize the system's dynamics is Markovian master equation (ME) which usually embodies two different forms, namely, the so-called local and global ones [7]. For the local ME, the jump operators act only on individual subsystems, whereas for the global ME, the jump operators, constructed in the eigenstate representation, act on the global degrees of freedom of the system. Generally speaking, which one of these two approaches is more accurate for a specific model relies on the competition of intrasystem interaction between subsystems and the dissipation rate. The applications of these two approaches in the study of QT become more subtle since improper choice of them will lead to thermodynamics inconsistency [8–15]. In particular, it has been shown that the local ME is unable to make the system reach thermal equilibrium even for weak system-environment interactions [16, 17], miss important effects in thermal quantum devices, such as heat leaks and internal dissipation [9, 18], and even violate the second law of thermodynamics with

counterintuitive results [19]. In other cases, however, the local ME is found to be more accurate than the global ME [11, 12]. Moreover, the global ME can fail to generate completely positive maps (in the Redfield type) [20] and be inadequate for the description of heat current in stationary nonequilibrium situations [21].

In many cases, the seeming inconsistencies in QT are due to the unawareness of extra energetic cost such as work in maintaining the thermodynamics process [19, 22]. By constructing microscopic model of local ME based on the framework of collision (repeated interaction) model [22–25], these thermodynamical inconsistencies can be resolved. In the collision model, the environment is assumed to be composed of a series of identical ancillas and the system of interest interacts, or collides, with a fresh one at each time step [26]. It proves to be a useful and versatile tool not only in simulating the dynamics of open quantum system [27–42], but also in dealing with QT [43–58]. In reference [23], Barra has recognized that in the collision model external work is required to switch on and off the successive collisions between the system and ancillas. As a result, a consistent thermodynamics framework can be established by using the collision-model-based local ME and introducing the work due to the system-environment collisions [22–25].

As the work is necessary in maintaining successive collisions between system and environment, how fashions of collisions (e.g., three-body and two-body interactions) affect amount and sign of the invested work, or which collision manner requires more work and can lead to specific direction of work current, becomes a question of both theoretical and practical importance. This issue is interesting in practical applications since the amount and sign of work will influence the operating regimes of thermal machines. Generally, for a system consisting of several subsystems, there are two types of interactions between the system and environments, namely, the subsystems interact independently with their own local environments and all subsystems interact simultaneously with a common one. At a more practical level, quantum systems would be more likely to interact with external environments both independently and simultaneously due to the difficulty in retaining only one type of interactions. In this work, by combining these two configurations together, we develop a model with two subsystems simultaneously interacting with a common reservoir apart from independent interactions with their local ones, which can involve three modes of collisions (cf figure 1). The three scenarios are embodied in the interactions between two subsystems and the common reservoir, which could be three-body one, two-body one with and without intrasystem interactions between subsystems. By means of collision model, we construct ME to describe the system's dynamics and formulate the heat, work and internal energy in their general forms. Focusing on the instance of two coupled qubits, we demonstrate that the work costs are sensitive to the manners of collisions, based on which various types of thermal machines can be realized. Generally, quantum thermal machines can be normally classified into three types [59–62] depending on how the system (working substance) is operated upon, namely, autonomous ones with time-independent Hamiltonian for the system, discrete-stroke ones characterized by thermodynamics process of finite-time intervals, and continuously driven ones where the system is permanently coupled to the baths with time-dependent Hamiltonian. From this classification, our constructed machines belong to continuously driven ones since the system can be considered to be permanently coupled to reservoirs and there is work cost associated with system-reservoir interactions. We also show that though the machine with the same function can be realized in different scenarios, which one is superior to others is not fixed but related to the chosen parameters. A possible implementation of the setup based on the platform of circuit quantum electrodynamics (QED) is discussed briefly. The bipartite model is finally generalized to the case with N subsystems and the corresponding formulations are derived.

This paper is organized as follows. In section 2, we introduce the model with two subsystems and construct the ME within the framework of collision model. In section 3, we establish the general expressions of changes of heat, work and internal energy in a single collision of system and reservoirs and show their consistency with the first law of thermodynamics. In section 4, focusing on a model of two coupled qubits, we derive concrete expressions of currents of heat and work in the continuous time limit and demonstrate the work costs, operating regimes as well as efficiency with respect to different modes of collisions. In section 5, we extend the model of two subsystems to the multipartite case. This work is concluded in section 6.

2. The model and master equation

In our model, as shown in figure 1, the system S consists of two subsystems S_1 and S_2 being coupled to the local reservoirs R_1 and R_2 , respectively, and in contact simultaneously with the common reservoir R_3 . By means of collision model, each reservoir R_j ($j = 1, 2, 3$) is modeled as a cluster of identically prepared ancillas and at each time a fresh one of them collides/interacts with the corresponding subsystem for a

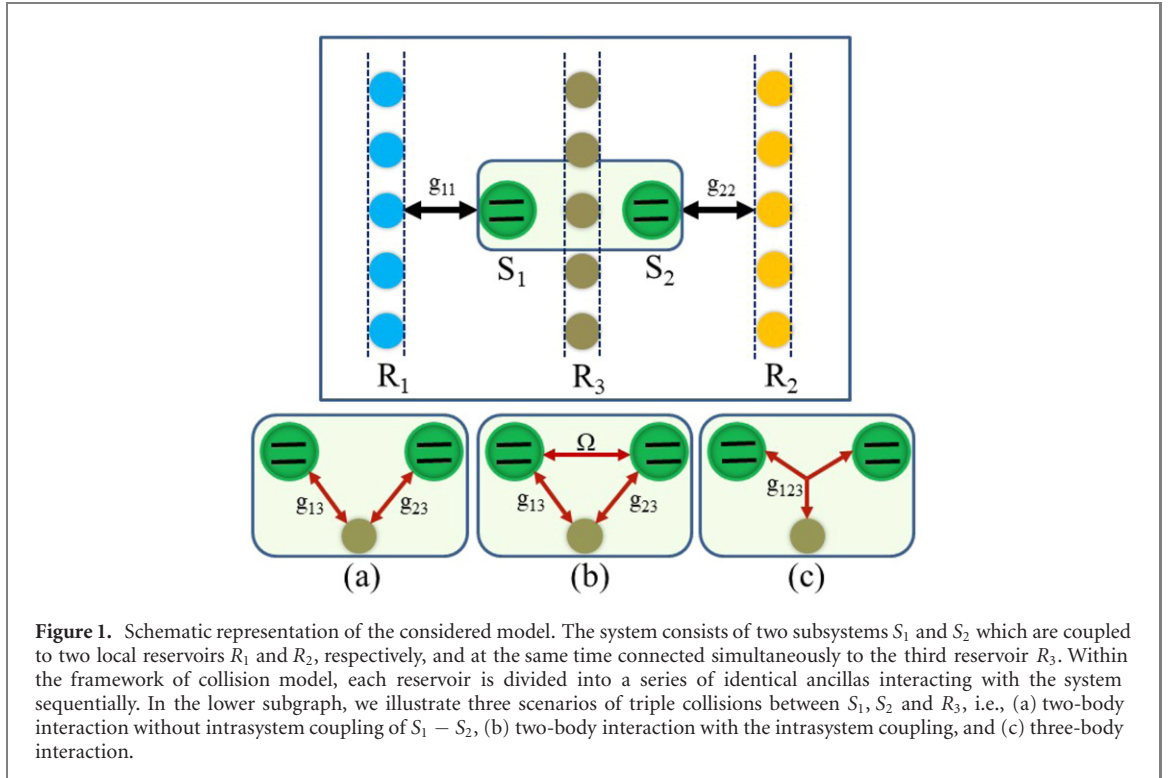

duration τ . For convenience, we adopt R_j to label both the reservoir and generic ancilla therein. The total Hamiltonian of the system plus reservoirs can be expressed as

$$\hat{H}_{\text{tot}} = \hat{H}_S + \sum_{j=1}^3 \hat{H}_{R_j} + \frac{1}{\sqrt{\tau}} \sum_{i=1}^2 \hat{V}_i + \frac{1}{\sqrt{\tau}} \hat{H}_I, \quad (1)$$

where \hat{H}_S is the Hamiltonian of the system, \hat{H}_{R_j} is the free Hamiltonian of ancilla in the reservoir R_j , \hat{V}_i stands for the boundary collisions between S_i and R_i , and \hat{H}_I accounts for the middle collisions between S_1 , S_2 and R_3 . For the convenience of taking continuous time limit later, we have scaled \hat{V}_i and \hat{H}_I by the collision time τ [58]. One purposes of this work is to reveal the cost of work to maintain different ways of the triple collisions of S_1 , S_2 and R_3 as well as their distinct effects on the thermodynamics process, so that we shall explore both the two-body (cf figures 1(a) and (b)) and three-body (cf figure 1(c)) interactions for \hat{H}_I . When \hat{H}_I is two-body interaction, we will take both the situations with and without intrasystem interaction of S_1 and S_2 into account, as shown in figures 1(a) and (b), respectively. Of course, due to the bridge of reservoir R_3 , the direct interaction between S_1 and S_2 is not necessary for the exchange of energy among reservoirs.

Before constructing ME based on the collision model, we make a brief discussion on the assumptions that justify the validity for using such an approach. We consider the most general system-reservoir interaction Hamiltonian of the form $\hat{H}_{SR} = g \sum_{\mu\nu} \hat{S}_\mu \hat{R}_\nu$ with g the strength of the coupling and \hat{S}_μ (\hat{R}_ν) are generic system (ancilla) operators. It is convenient to assume that the coupling strength is proportional to the collision time in terms of $g \propto 1/\sqrt{\tau}$. Since the ME is valid for the short collision time, only a diverging coupling strength can ensure a meaningful contribution from the system-reservoir interaction. Consider the system's Hamiltonian $\hat{H}_S = \omega \sum_i \hat{S}_i$, where the intrinsic system evolution timescale $t_S = 1/\omega$ is set by the system's characteristic frequency ω . We assume $t_S \ll \tau$ (i.e., $\omega\tau \gg 1$) so that the neglect of system's evolution between subsequent collisions can be verified. A single shot of collision at time t transforms the state $\rho_S \equiv \rho_S(t)$ of the system to $\rho'_S \equiv \rho'_S(t + \tau)$ as

$$\rho'_S = \text{Tr}_R \rho'_{SR} = \text{Tr}_R \left\{ \hat{U}_{SR} \rho_{SR} \hat{U}_{SR}^\dagger \right\}, \quad (2)$$

where $\rho_{SR} \equiv \rho_S \otimes \rho_R$ with $\rho_R = \prod_{j=1}^3 \rho_{R_j}$ the total initial state of three ancillas and $\hat{U}_{SR} = e^{-i\tau \hat{H}_{\text{tot}}}$ is the unitary time evolution operator. As usual, we assume that the ancilla R_j is prepared in a thermal state at inverse temperature $\beta_{R_j} = 1/T_{R_j}$, namely, $\rho_{R_j} = e^{-\beta_{R_j} \hat{H}_{R_j}} / Z_{R_j}$ with $Z_{R_j} = \text{tr} \{ e^{-\beta_{R_j} \hat{H}_{R_j}} \}$ the corresponding partition function. We set $\hbar = k_B = 1$ here and throughout the paper. By expanding \hat{U}_{SR} up to the first

order in τ , we derive the ME of the system as

$$\begin{aligned}\dot{\rho}_S &= \lim_{\tau \rightarrow 0} [(\rho'_S - \rho_S) / \tau] \\ &= -i [\hat{H}_S, \rho_S] + \sum_{i=1}^2 \mathcal{D}_i + \mathcal{G},\end{aligned}\quad (3)$$

where \mathcal{D}_i and \mathcal{G} are the dissipative terms associated with the local reservoir R_i and the common one R_3 being of the forms

$$\mathcal{D}_i = -\frac{1}{2} \text{Tr}_{R_i} [\hat{V}_i, [\hat{V}_i, \rho_S \rho_{R_i}]], \quad (4)$$

and

$$\mathcal{G} = -\frac{1}{2} \text{Tr}_{R_3} [\hat{H}_I, [\hat{H}_I, \rho_S \rho_{R_3}]]. \quad (5)$$

3. Thermodynamics quantities via collision model

By resorting to the collision model, in this section, we establish general formulations of changes of heat, work and internal energy in a single round of collisions. In deriving the thermodynamics quantities, \hat{U}_{SR} will be approximated up to the first order in τ throughout the paper. During a single collision, the heat transferred from the three reservoirs to the system can be defined unambiguously as their energy decreases as

$$\begin{aligned}\Delta Q &= -\sum_{j=1}^3 \left(\langle \hat{H}_{R_j} \rangle_{\rho'_{SR}} - \langle \hat{H}_{R_j} \rangle_{\rho_{SR}} \right) \\ &= \frac{\tau}{2} \sum_{i=1}^2 \langle [\hat{V}_i, [\hat{V}_i, \hat{H}_{R_i}]] \rangle_{\rho_{SR}} + \frac{\tau}{2} \langle [\hat{H}_I, [\hat{H}_I, \hat{H}_{R_3}]] \rangle_{\rho_{SR}},\end{aligned}\quad (6)$$

where $\langle \cdot \rangle_{\rho} = \text{Tr}[\cdot \rho]$. Obviously, the first term of the second line in the right-hand side (rhs) of ΔQ , equation (6), is associated to the boundary reservoirs R_i with $i = 1, 2$, while the second term is due to the common reservoir R_3 .

To guarantee thermodynamics consistence of the model, we should take the work exerted by external agent into account. The work in a quantum system is generally defined as a change of internal energy due to the modification of Hamiltonian of the system by some external control parameters. The cost of work is apparent in collision model since the system should be successively coupled to and decoupled from the reservoirs, leading to the time dependence of total Hamiltonian. In most studies [22, 23, 25], only two-body system-reservoir interaction is involved, which constrains the form of work supplied by external agent. Here, by introducing simultaneous collisions of S_1 and S_2 with R_3 , we consider both two-body and three-body interactions among them, which allow us on the one hand to compare the work cost in maintaining different ways of collisions, and on the other hand to achieve various operating regimes of the system functioning as thermal machines.

For the unitary dynamics of overall system and reservoirs, the work in a single collision that occurs within the time interval $[t, t + \tau]$ can be defined as

$$\Delta W = \int_t^{t+\tau} \text{Tr} \left[\frac{\partial \hat{H}_{\text{tot}}}{\partial s} \rho_{SR} \right] ds. \quad (7)$$

Since \hat{V}_i and \hat{H}_I are the only time-dependent terms in \hat{H}_{tot} in the sense that they exists in $[t, t + \tau]$ and vanishes otherwise, an integration over equation (7) yields

$$\begin{aligned}\Delta W &= \frac{1}{\sqrt{\tau}} \left\langle \hat{H}_I + \sum_{i=1}^2 \hat{V}_i \right\rangle_{\rho_{SR}} - \frac{1}{\sqrt{\tau}} \left\langle \hat{H}_I + \sum_{i=1}^2 \hat{V}_i \right\rangle_{\rho'_{SR}} \\ &= -\frac{\tau}{2} \langle [\hat{H}_I, [\hat{H}_I, \hat{H}_S + \hat{H}_{R_3}]] \rangle_{\rho_{SR}} \\ &\quad - \frac{\tau}{2} \sum_{i=1}^2 \langle [\hat{V}_i, [\hat{V}_i, \hat{H}_S + \hat{H}_{R_i}]] \rangle_{\rho_{SR}}.\end{aligned}\quad (8)$$

The formulation (8) indicates that the conditions for a finite nonzero work is either $[\hat{H}_I, \hat{H}_S + \hat{H}_{R_3}] \neq 0$ or $[\hat{V}_i, \hat{H}_S + \hat{H}_{R_i}] \neq 0$. Yet, the work associated to these two conditions represents two different sources: the first one originates from the triple collisions of S_1 , S_2 and R_3 , while the second one from the boundary collisions of $S_1 - R_1$ and $S_2 - R_2$. No work is required if and only if $[\hat{H}_I, \hat{H}_S + \hat{H}_{R_3}] = 0$ and meanwhile $[\hat{V}_i, \hat{H}_S + \hat{H}_{R_i}] = 0$ for $i = 1, 2$, which mean strict energy conservation for all the involved collisions.

Next, we derive the expression of the change of system's internal energy and verify the thermodynamics consistency of these quantities. The change of internal energy of the system can be defined as

$$\begin{aligned} \Delta E_S &= \sum_{i=1}^2 \left(\langle \hat{H}_{S_i} \rangle_{\rho'_{SR}} - \langle \hat{H}_{S_i} \rangle_{\rho_{SR}} \right) \\ &= -\frac{\tau}{2} \langle [\hat{H}_I, [\hat{H}_I, \hat{H}_S]] \rangle_{\rho_{SR}} - \frac{\tau}{2} \sum_{i=1}^2 \langle [\hat{V}_i, [\hat{V}_i, \hat{H}_S]] \rangle_{\rho_{SR}}. \end{aligned} \quad (9)$$

From equations (6), (8) and (9), we can get $\Delta E_S = \Delta W + \Delta Q$, namely, our derived quantities comply with the first law of thermodynamics. By definition, the positive work and heat mean that the energy is transferred to the system.

4. Two coupled qubits

In order to demonstrate our results, we consider a concrete model (see figure 1) which consists of two two-level subsystems (qubits) S_1 and S_2 , with the free Hamiltonian $\hat{H}_{S_i} = \frac{\omega_{S_i}}{2} \hat{\sigma}_{S_i}^z$ and frequency ω_{S_i} ($i = 1, 2$), interacting locally with their own reservoirs R_1 and R_2 , respectively. Here, $\hat{\sigma}_A^{x(y,z)}$ is the usual Pauli operator for the qubit A . Additionally, we introduce simultaneous collisions of S_1 and S_2 with a third reservoir R_3 , which could be two-body and three-body ones. Here, the reservoir ancilla R_j with $j = 1, 2, 3$ is also modeled as a qubit with the generic Hamiltonian $\hat{H}_{R_j} = \frac{\omega_{R_j}}{2} \hat{\sigma}_{R_j}^z$ and frequency ω_{R_j} . The local interaction for $S_i - R_j$ is given as

$$\hat{V}_i = g_{ii} \left(\hat{\sigma}_{S_i}^+ \hat{\sigma}_{R_j}^- + \hat{\sigma}_{S_i}^- \hat{\sigma}_{R_j}^+ \right), \quad (10)$$

in which $\hat{\sigma}_A^\pm = (\sigma_A^x \pm i\sigma_A^y)/2$ are the raising/lowering operators on A and g_{ii} denotes the interaction strength for S_i and R_j . The environment ancilla R_j is prepared in the thermal state with

$$\rho_{R_j} = [(1 - \xi_j)/2] |1\rangle \langle 1| + [(1 + \xi_j)/2] |0\rangle \langle 0|, \quad (11)$$

where $\xi_j = \tanh(\beta_{R_j} \omega_{R_j}/2)$ with $\beta_{R_j} = 1/T_{R_j}$ the inverse temperature of R_j . In the following, we shall consider two-body and three-body interactions for S_1 , S_2 and R_3 in the subsections 4.1 and 4.2, respectively, and derive the currents of heat and work in the limit of continuous time.

4.1. Two-body interaction

The simultaneous interactions of S_1 and S_2 with R_3 in the two-body form can be expressed as

$$\hat{H}_I^{(2)} = (g_{13} \hat{\sigma}_{S_1}^+ + g_{23} \hat{\sigma}_{S_2}^+) \hat{\sigma}_{R_3}^- + \text{h.c.}, \quad (12)$$

in which g_{13} and g_{23} characterize the coupling strengths of $S_1 - R_3$ and $S_2 - R_3$, respectively. In this configuration, the energy exchange can be realized via the bridge of the reservoir ancilla R_3 so that the direct contact between S_1 and S_2 is not necessary. However, we will still take the existence of intrasystem interaction of S_1 and S_2 , as a special instance, into account when comparing the cost of work in different situations, which is given as

$$\hat{H}_{S_1 S_2} = \Omega (\hat{\sigma}_{S_1}^+ \hat{\sigma}_{S_2}^- + \hat{\sigma}_{S_1}^- \hat{\sigma}_{S_2}^+), \quad (13)$$

with Ω the interacting constant.

The system's dynamics is described by the ME (3) with the dissipative terms are given as

$$\begin{aligned} \mathcal{D}_i &= g_{ii}^2 \chi_{R_i}^g \left(\hat{\sigma}_{S_i}^- \rho_S \hat{\sigma}_{S_i}^+ - \frac{1}{2} \left\{ \hat{\sigma}_{S_i}^+ \hat{\sigma}_{S_i}^-, \rho_S \right\} \right) \\ &\quad + g_{ii}^2 \chi_{R_i}^e \left(\hat{\sigma}_{S_i}^+ \rho_S \hat{\sigma}_{S_i}^- - \frac{1}{2} \left\{ \hat{\sigma}_{S_i}^- \hat{\sigma}_{S_i}^+, \rho_S \right\} \right), \end{aligned} \quad (14)$$

and

$$\begin{aligned}
 \mathcal{G} = & \chi_{R_3}^g \sum_{i=1}^2 g_{i3}^2 \left(\hat{\sigma}_{S_i}^- \rho_S \hat{\sigma}_{S_i}^+ - \frac{1}{2} \left\{ \hat{\sigma}_{S_i}^+ \hat{\sigma}_{S_i}^-, \rho_S \right\} \right) \\
 & + \chi_{R_3}^e \sum_{i=1}^2 g_{i3}^2 \left(\hat{\sigma}_{S_i}^+ \rho_S \hat{\sigma}_{S_i}^- - \frac{1}{2} \left\{ \hat{\sigma}_{S_i}^- \hat{\sigma}_{S_i}^+, \rho_S \right\} \right) \\
 & + \chi_{R_3}^g g_{13} g_{23} \left(\hat{\sigma}_{S_1}^- \rho_S \hat{\sigma}_{S_2}^+ - \frac{1}{2} \left\{ \hat{\sigma}_{S_1}^- \hat{\sigma}_{S_2}^+, \rho_S \right\} \right. \\
 & \left. + \hat{\sigma}_{S_2}^- \rho_S \hat{\sigma}_{S_1}^+ - \frac{1}{2} \left\{ \hat{\sigma}_{S_1}^+ \hat{\sigma}_{S_2}^-, \rho_S \right\} \right) \\
 & + \chi_{R_3}^e g_{13} g_{23} \left(\hat{\sigma}_{S_1}^+ \rho_S \hat{\sigma}_{S_2}^- - \frac{1}{2} \left\{ \hat{\sigma}_{S_1}^+ \hat{\sigma}_{S_2}^-, \rho_S \right\} \right. \\
 & \left. + \hat{\sigma}_{S_2}^+ \rho_S \hat{\sigma}_{S_1}^- - \frac{1}{2} \left\{ \hat{\sigma}_{S_1}^- \hat{\sigma}_{S_2}^+, \rho_S \right\} \right), \tag{15}
 \end{aligned}$$

where $\chi_{R_j}^g = \langle \hat{\sigma}_{R_j}^- \hat{\sigma}_{R_j}^+ \rangle_{\rho_{R_j}}$ and $\chi_{R_j}^e = \langle \hat{\sigma}_{R_j}^+ \hat{\sigma}_{R_j}^- \rangle_{\rho_{R_j}}$ for $j = 1, 2, 3$. In the unitary term of (3), if the intrasystem interaction is taken into account we have $\hat{H}_S = \sum_{i=1}^2 \hat{H}_{S_i} + \hat{H}_{S_1 S_2}$, otherwise $\hat{H}_S = \sum_{i=1}^2 \hat{H}_{S_i}$.

By means of equation (6), the heat current flowed from the boundary reservoir R_i ($i = 1, 2$) to the system can be derived as

$$\dot{Q}_i^{(2)} = g_{ii}^2 \omega_{R_i} \left(\chi_{R_i}^e \chi_{S_i}^g - \chi_{R_i}^g \chi_{S_i}^e \right), \tag{16}$$

while that from the middle reservoir R_3 to the system as

$$\dot{Q}_3^{(2)} = \sum_{i=1}^2 g_{i3}^2 \omega_{R_3} \left(\chi_{R_3}^e \chi_{S_i}^g - \chi_{R_3}^g \chi_{S_i}^e \right), \tag{17}$$

where $\chi_{S_i}^g = \langle \hat{\sigma}_{S_i}^- \hat{\sigma}_{S_i}^+ \rangle_{\rho_S}$ and $\chi_{S_i}^e = \langle \hat{\sigma}_{S_i}^+ \hat{\sigma}_{S_i}^- \rangle_{\rho_S}$ for $i = 1, 2$. In the absence of the intrasystem interaction $\hat{H}_{S_1 S_2}$ (13), the work current can be obtained via equation (8) as

$$\begin{aligned}
 \dot{W}_0^{(2)} = & \sum_{i=1}^2 g_{ii}^2 (\omega_{S_i} - \omega_{R_i}) \left(\chi_{R_i}^e \chi_{S_i}^g - \chi_{R_i}^g \chi_{S_i}^e \right) \\
 & + \sum_{i=1}^2 g_{i3}^2 (\omega_{S_i} - \omega_{R_3}) \left(\chi_{R_3}^e \chi_{S_i}^g - \chi_{R_3}^g \chi_{S_i}^e \right) \\
 & + g_{13} g_{23} \chi_S^{\text{coh}} \left(\omega_{R_3} - \frac{1}{2} \sum_{i=1}^2 \omega_{S_i} \right) (\chi_{R_3}^g - \chi_{R_3}^e), \tag{18}
 \end{aligned}$$

in which $\chi_S^{\text{coh}} = \langle \hat{\sigma}_{S_1}^+ \hat{\sigma}_{S_2}^- + \hat{\sigma}_{S_1}^- \hat{\sigma}_{S_2}^+ \rangle_{\rho_S}$. We observe that the first term in the rhs of equation (18) is related to the boundary collisions of S_i and R_i , which will vanish if $\omega_{S_i} = \omega_{R_i}$ for $i = 1, 2$ implying that the collisions are energy preserving with $[\hat{V}_i, \hat{H}_{S_i} + \hat{H}_{R_i}] = 0$. The last two terms in equation (18) are associated with the middle collisions between S_1, S_2 and R_3 , which will become zero when $\omega_{S_1} = \omega_{S_2} = \omega_{R_3}$ implying also the energy conservation of the collisions with $[\hat{H}_I^{(2)}, \hat{H}_{S_1} + \hat{H}_{S_2} + \hat{H}_{R_3}] = 0$. We note that the correlation between S_1 and S_2 in terms of χ_S^{coh} make significant contribution to the work current in a sense that the last term of $\dot{W}_0^{(2)}$ disappears if $\chi_S^{\text{coh}} = 0$.

When the intrasystem interaction $\hat{H}_{S_1 S_2}$ (13) is involved, the work current $\dot{W}_I^{(2)} = \dot{W}_0^{(2)} + \dot{W}_1^{(2)}$, i.e., another term $\dot{W}_1^{(2)}$ should be added to (18), with $\dot{W}_1^{(2)}$ being of the form

$$\begin{aligned}
 \dot{W}_1^{(2)} = & -\frac{1}{2} (g_{11}^2 + g_{22}^2 + g_{13}^2 + g_{23}^2) \langle \hat{H}_{S_1 S_2} \rangle_{\rho_S} \\
 & - \Omega g_{13} g_{23} \chi_{R_3}^g (\chi_S^{ge} - 2\chi_S^{ee} + \chi_S^{eg}) \\
 & - \Omega g_{13} g_{23} \chi_{R_3}^e (\chi_S^{eg} - 2\chi_S^{gg} + \chi_S^{ge}), \tag{19}
 \end{aligned}$$

where $\chi_S^{ge} = \langle \hat{\sigma}_{S_1}^- \hat{\sigma}_{S_1}^+ \hat{\sigma}_{S_2}^+ \hat{\sigma}_{S_2}^- \rangle_{\rho_S}$, $\chi_S^{eg} = \langle \hat{\sigma}_{S_1}^+ \hat{\sigma}_{S_1}^- \hat{\sigma}_{S_2}^- \hat{\sigma}_{S_2}^+ \rangle_{\rho_S}$, $\chi_S^{ee} = \langle \hat{\sigma}_{S_1}^+ \hat{\sigma}_{S_1}^- \hat{\sigma}_{S_2}^+ \hat{\sigma}_{S_2}^- \rangle_{\rho_S}$, and $\chi_S^{gg} = \langle \hat{\sigma}_{S_1}^- \hat{\sigma}_{S_1}^+ \hat{\sigma}_{S_2}^- \hat{\sigma}_{S_2}^+ \rangle_{\rho_S}$.

4.2. Three-body interaction

We proceed to the scenario of three-body collision of S_1 , S_2 and R_3 governed by

$$\hat{H}_I^{(3)} = g_{123} (\hat{\sigma}_{S_1}^+ \hat{\sigma}_{R_3}^- \hat{\sigma}_{S_2}^+ + \hat{\sigma}_{S_1}^- \hat{\sigma}_{R_3}^+ \hat{\sigma}_{S_2}^-), \quad (20)$$

with g_{123} standing for the strength of three-body interaction. The system's dynamics is still described by the ME (3) with the dissipative term \mathcal{D}_i being identical to that given in (14), while the term \mathcal{G} is now given as

$$\begin{aligned} \mathcal{G} = g_{123}^2 & \left[\chi_{R_3}^g \left(\hat{\sigma}_{S_1}^- \hat{\sigma}_{S_2}^- \rho_S \hat{\sigma}_{S_1}^+ \hat{\sigma}_{S_2}^+ - \frac{1}{2} \{ \hat{\sigma}_{S_1}^+ \hat{\sigma}_{S_2}^+ \hat{\sigma}_{S_1}^- \hat{\sigma}_{S_2}^-, \rho_S \} \right) \right. \\ & \left. + \chi_{R_3}^e \left(\hat{\sigma}_{S_1}^+ \hat{\sigma}_{S_2}^+ \rho_S \hat{\sigma}_{S_1}^- \hat{\sigma}_{S_2}^- - \frac{1}{2} \{ \hat{\sigma}_{S_1}^- \hat{\sigma}_{S_2}^- \hat{\sigma}_{S_1}^+ \hat{\sigma}_{S_2}^+, \rho_S \} \right) \right]. \end{aligned} \quad (21)$$

The expression of heat current from the boundary reservoir R_i ($i = 1, 2$) to the system is the same as that presented in (16), i.e., $\dot{Q}_i^{(3)} = \dot{Q}_i^{(2)}$, while that from the common reservoir R_3 becomes

$$\dot{Q}_3^{(3)} = g_{123}^2 \omega_{R_3} (\chi_{R_3}^e \chi_S^{gg} - \chi_{R_3}^g \chi_S^{ee}). \quad (22)$$

By means of equation (8), the work current in the regime of three-body collision can be formulated as

$$\begin{aligned} \dot{W}^{(3)} = \sum_{i=1}^2 g_{ii}^2 (\omega_{S_i} - \omega_{R_i}) & (\chi_{R_i}^e \chi_{S_i}^g - \chi_{R_i}^g \chi_{S_i}^e) \\ & + g_{123}^2 \left(\sum_{i=1}^2 \omega_{S_i} - \omega_{R_3} \right) (\chi_{R_3}^e \chi_S^{gg} - \chi_{R_3}^g \chi_S^{ee}). \end{aligned} \quad (23)$$

Obviously, the first term in the rhs of equation (23) originates from the boundary collisions of S_i and R_i , coinciding with that given in equation (18) of the two-body interaction. By contrast, the second term in the rhs of (23) just accounts for the work sustaining the three-body collision, which will vanish if $\sum_{i=1}^2 \omega_{S_i} - \omega_{R_3} = 0$, namely, the interaction preserves the energy with $[\hat{H}_I^{(3)}, \hat{H}_{S_1} + \hat{H}_{S_2} + \hat{H}_{R_3}] = 0$.

4.3. Results

So far, we have derived concrete expressions of ME and formulations of currents of heat and work for both the two-body and three-body collisions between S_1 , S_2 and R_3 . The two-body case further includes two situations with and without intrasystem interaction between S_1 and S_2 . In the steady-state regime, work current will vanish if variations of system's internal energy can be accounted for completely by heat flows among the relevant reservoirs. Otherwise, a finite nonzero work current should be supplied by external agent, which occurs when collisions of system-reservoirs cannot guarantee conservation of total energy of system and reservoirs, as discussed above. In the following, we shall make a comparison for the work currents required to maintain the collisions in these three configurations. We also display the operating regimes that could be produced for the system functioning as thermal machines. In order to lay stress on the work exerted due to the triple collisions of S_1 , S_2 and R_3 , we set energy conservation for the boundary collisions of $S_i - R_i$ in such a way that $\omega_{S_i} = \omega_{R_i}$ so that no work will be required for them. In figure 2, we display steady-state work currents against ω_{R_3} for different temperatures of the three reservoirs. We can observe that the work currents exhibit striking contrasts, in both amounts and directions, with respect to the three-body collision in terms of $\dot{W}^{(3)}$ and two-body collisions in terms of $\dot{W}_0^{(2)}$ and $\dot{W}_I^{(2)}$. For the two-body collision, the work currents in the presence and absence of intrasystem interactions between subsystems, represented by $\dot{W}_I^{(2)}$ and $\dot{W}_0^{(2)}$, also differ from each other, particularly for the transforming points between positive and negative values. Our results suggest that the work current needed in the collision model is closely related to the manners of interactions which, through appropriate choices, prove to be a possible method to realize machines with demanding functions as shown in the following.

Concentrating on the setting of $T_{R_1} < T_{R_3} < T_{R_2}$, we find that there appear to be six types of operating regimes of the machine characterized by the signs of \dot{Q}_1 , \dot{Q}_2 , \dot{Q}_3 and \dot{W} , as shown in table 1. Due to $T_{R_3} < T_{R_2}$, the extraction of heat from the reservoir R_3 to the reservoir R_2 can be viewed as a refrigerator, labeled by I and II. For the type I, we have $\dot{W} > 0$, namely, external work is performed on the system to achieve the refrigeration of R_3 so that we call it as T_{R_3} -power driven refrigerator. By contrast, in the type II, only through the driving of the heat currents can the machine cool the reservoir R_3 and meanwhile produce

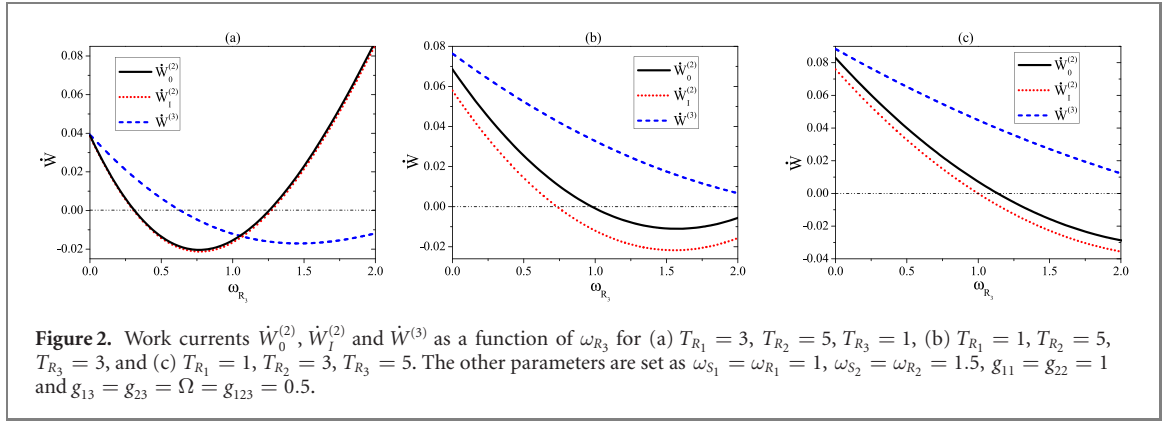

Table 1. Table of operating regimes of the machine. The first column shows the labels of different regimes; the second column describes the function and characters of the machine; the remaining columns give the signs of the heat and work currents.

Label	Description	\dot{Q}_1	\dot{Q}_2	\dot{Q}_3	\dot{W}
I	T_{R_3} -power driven refrigerator	<0	<0	>0	>0
II	T_{R_3} -heat driven refrigerator with work production	<0	<0	>0	<0
III	Dual-source accelerator	<0	>0	>0	>0
IV	Dual-source engine	<0	>0	>0	<0
V	Dual-sink thermal engine	<0	>0	<0	<0
VI	Dual-sink accelerator	<0	>0	<0	>0

work. In the types III and VI, the machine works as an accelerator (oven) [63] by acquiring external work and transporting heat from the dual sources R_2 and R_3 to R_1 in III, while dumping heat to the dual sinks R_1 and R_3 from R_2 in VI. The types IV and V are recognized as thermal engines extracting work from the system and at the same time transferring heat from dual sources R_2 and R_3 to R_1 in IV and dumping heat to the dual sinks R_1 and R_3 from R_2 in V. In figure 3, by plotting all the involved thermodynamics quantities, i.e., currents of work \dot{W} and heats \dot{Q}_1 , \dot{Q}_2 and \dot{Q}_3 from reservoirs R_1 , R_2 and R_3 , respectively, we identify parameter ranges for the appearances of these six operating regimes of the machines. For clearness, we omit the superscripts in these thermodynamics quantities. Here, the cases of three-body collision, two-body collision with and without intrasystem interaction are demonstrated in figures 3(a)–(c), respectively. We observe that two operating regimes can be achieved for the three-body collision, while four and five ones can occur for the two-body collision with and without intrasystem interaction. Moreover, the refrigerator of type II can be realized only in the situation of three-body collision, figure 3(a). For the other types of operating regimes, though they can be obtained in different scenarios, the parameter intervals supporting them are different. Therefore, the operating regimes are closely related to the manners of collisions for the given parameters. Alternatively speaking, one can choose suitable collision types and parameter ranges to implement thermal machines with specific functions.

From above discussions, we know that the same operating regime can happen in different scenarios of collisions. For example, the refrigerator of type I appears in both the cases of three-body collision, figure 3(a), and two-body collision without intrasystem interaction, figure 3(c). Hence, it is interesting to make a comparison for the efficiency or coefficient of performance (COP) of the same types of machines in different configurations. The COP of a refrigerator is defined as the ratio of the extracted heat \dot{Q}_c from the cold reservoir to the invested work \dot{W} , namely, $\text{COP} = \dot{Q}_c / \dot{W}$. The efficiency of an engine is defined as $\eta = |\dot{W}| / \dot{Q}_h$, namely, the ration of the produced work $|\dot{W}|$ to heat \dot{Q}_h extracted from the hot reservoir. In figure 4(a), we compare the COP of the refrigerator of type I that appears in the situations of three-body collision (i.e., the range I in figure 3(a)) and two-body collision without intrasystem interaction (i.e., the range I in figure 3(c)). We find that the COP in the case of two-body collision is always larger than that of three-body collision for the interval of ω_{R_3} enabling this refrigerator in both cases. In spite of the efficiency advantage of the two-body collision in producing the type I refrigerator, however, the three-body collision can realize it in the wider range of ω_{R_3} , as shown in figures 3(a) and (c). Figure 4(b) shows the efficiency of thermal engine of type IV emerging in the situations of two-body collision with (i.e., the range IV in figure 3(b)) and without (i.e., the range IV in figure 3(c)) the intrasystem interaction. One can see that the efficiency of the former case is larger than the latter one for the relatively small ω_{R_3} , which is reversed with increasing ω_{R_3} . Similar results can be obtained for the efficiency of thermal engine of type V shown in

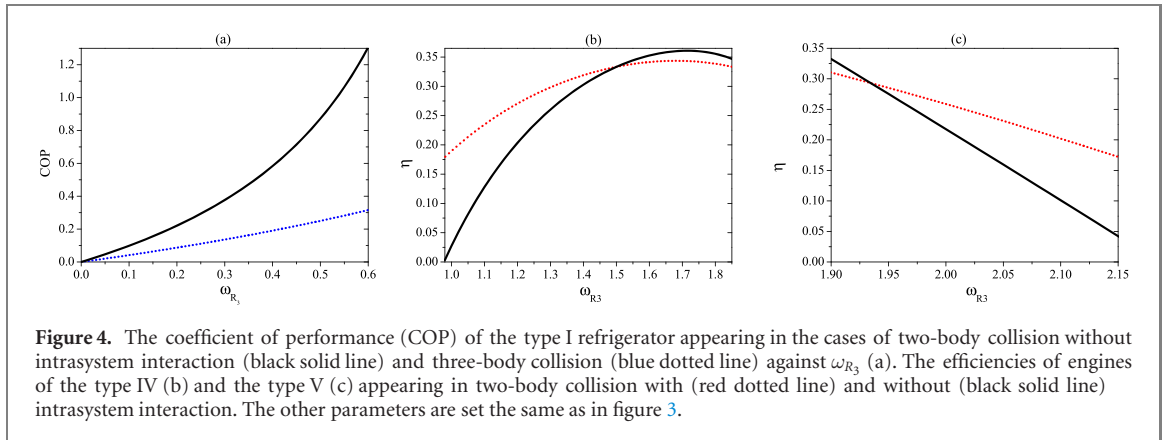
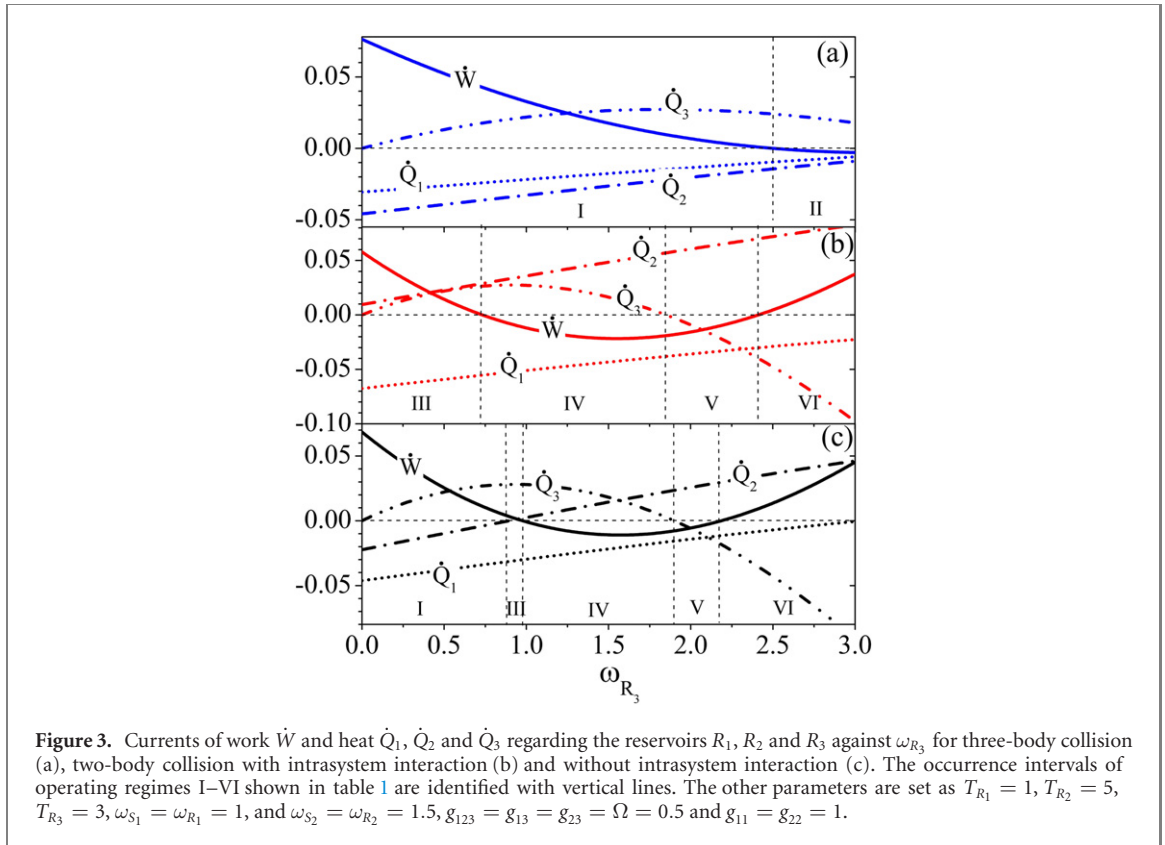
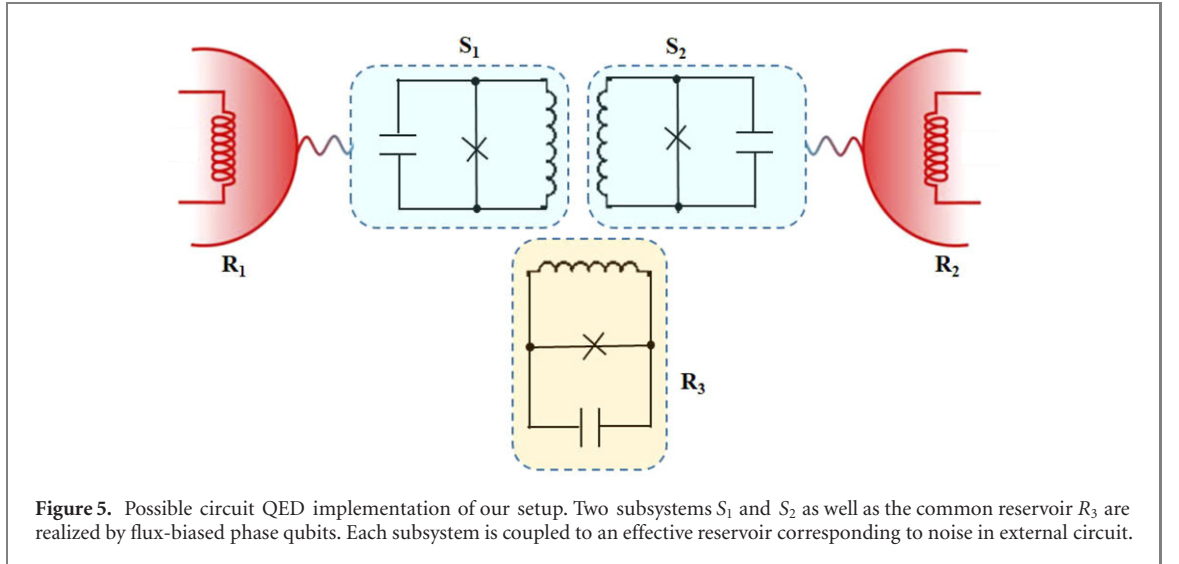

figure 4(c). Therefore, the advantage of an interaction in realizing a special machine is not fixed but relying on the ranges of parameters.

In the following, we discuss possible implementation of our setup in the platform of circuit QED, as shown in figure 5. The superconducting systems are potential candidates for implementing quantum thermal machines [64–66] and by which experimental studies of QT have already been realized [67–70]. The subsystems S_1 and S_2 in our model are realized by flux-biased phase qubits. The independent reservoir R_1 (R_2) associated with S_1 (S_2) is naturally generated due to the presence of thermal Johnson Nyquist noise in the surrounding circuitry and can be implemented by controlling the electronic noise coupling to each qubit. The common reservoir R_3 that interacts simultaneously with S_1 and S_2 is modeled by a flux-biased phase qubit as well. The two-body interactions between the three qubits can be realized in several coupling mechanisms, such as capacitive or inductive coupling via a cavity in the dispersive regime (of strong detuning of the qubits and cavity from the strength of the qubit-cavity coupling) [71], and direct mutual inductive coupling as described in [72]. The most challenging task in experiment for this model is the implementation of three-body interaction. Fortunately, the indirect three-body interaction can be achieved from the transmission of basic two-body ones after imposing proper condition of detuning [73, 74].



5. Generalization to the multipartite system

So far, we have discussed the model of two subsystems interacting independently with two local reservoirs and simultaneously with a common one. Focusing on different manners of interactions of the two subsystems with the common one, we have formulated the thermodynamics quantities and compare their behaviors in different configurations. In this section, we generalize above results to the system of N subsystems S_1, S_2, \dots, S_N . In addition to the local reservoir R_i ($i = 1, 2 \dots N$) coupled to each subsystem S_i , the total system is in contact with a common one labeled as R_c . By means of collision model approach, all the reservoirs are modeled as a series of identically prepared ancillas, each of which collides with the corresponding system only once and is replaced by a fresh one in the next collision. The Hamiltonian of the system read

$$\hat{H}_S = \sum_{i=1}^N \hat{H}_{S_i} + \hat{H}_{SS}, \quad (24)$$

where \hat{H}_{S_i} is the Hamiltonian of subsystem S_i and \hat{H}_{SS} summarizes intrasystem interactions between subsystems, if exist. The total Hamiltonian of the system plus reservoirs can be expressed as

$$\hat{H}_{\text{tot}} = \hat{H}_S + \sum_{i=1}^N \hat{H}_{R_i} + \hat{H}_{R_c} + \frac{1}{\sqrt{\tau}} \sum_{i=1}^N \hat{V}_i + \frac{1}{\sqrt{\tau}} \hat{H}_I, \quad (25)$$

where \hat{H}_{R_i} (\hat{H}_{R_c}) is the free Hamiltonian of ancilla in the reservoir R_i (R_c), \hat{V}_i stands for the local interaction between S_i and R_i , and \hat{H}_I accounts for the simultaneous interactions of all the subsystems with R_c .

A round of collisions transform the state ρ_S of the system at time t to ρ'_S at time $t + \tau$ as

$$\rho'_S = \text{Tr}_R \rho'_{SR} = \text{Tr}_R \left\{ \hat{U}_{SR} \rho_S \hat{U}_{SR}^\dagger \right\}, \quad (26)$$

where $\rho_{SR} \equiv \rho_S \otimes \rho_R$ with $\rho_R = \prod_{i=1}^N \rho_{R_i} \otimes \rho_{R_c}$ the total initial state of the $N + 1$ ancillas and $\hat{U}_{SR} = e^{-i\tau \hat{H}_{\text{tot}}}$ is the unitary time evolution operator. We assume that all the ancillas are prepared in the thermal states. By expanding \hat{U}_{SR} up to the first order in τ , we derive the ME of the system as

$$\begin{aligned} \dot{\rho}_S &= \lim_{\tau \rightarrow 0} [(\rho'_S - \rho_S) / \tau] \\ &= -i [\hat{H}_S, \rho_S] + \sum_{i=1}^N \mathcal{D}_i + \mathcal{G}, \end{aligned} \quad (27)$$

where

$$\mathcal{D}_i = -\frac{1}{2} \text{Tr}_{R_i} [\hat{V}_i, [\hat{V}_i, \rho_S \rho_{R_i}]], \quad (28)$$

and

$$\mathcal{G} = -\frac{1}{2} \text{Tr}_{R_c} [\hat{H}_I, [\hat{H}_I, \rho_S \rho_{R_c}]]. \quad (29)$$

During a single collision, the heat transferred from the $N + 1$ reservoirs to the system can be given as

$$\begin{aligned}\Delta Q &= -\sum_{i=1}^N \left(\langle \hat{H}_{R_i} \rangle_{\rho'_{SR}} - \langle \hat{H}_{R_i} \rangle_{\rho_{SR}} \right) - \left(\langle \hat{H}_{R_c} \rangle_{\rho'_{SR}} - \langle \hat{H}_{R_c} \rangle_{\rho_{SR}} \right) \\ &= \frac{\tau}{2} \sum_{i=1}^N \langle [\hat{V}_i, [\hat{V}_i, \hat{H}_{R_i}]] \rangle_{\rho_{SR}} + \frac{\tau}{2} \langle [\hat{H}_I, [\hat{H}_I, \hat{H}_{R_c}]] \rangle_{\rho_{SR}},\end{aligned}\quad (30)$$

in which the first term is related to the local reservoirs R_i , while the second term represents the heat of the common reservoir R_c . The work that takes place within the time interval $[t, t + \tau]$ of a round of collisions can be formulated as

$$\begin{aligned}\Delta W &= \frac{1}{\sqrt{\tau}} \left\langle \hat{H}_I + \sum_{i=1}^N \hat{V}_i \right\rangle_{\rho_{SR}} - \frac{1}{\sqrt{\tau}} \left\langle \hat{H}_I + \sum_{i=1}^N \hat{V}_i \right\rangle_{\rho'_{SR}} \\ &= -\frac{\tau}{2} \sum_{i=1}^N \langle [\hat{V}_i, [\hat{V}_i, \hat{H}_I + \hat{H}_{R_i}]] \rangle_{\rho_{SR}} \\ &\quad - \frac{\tau}{2} \langle [\hat{H}_I, [\hat{H}_I, \hat{H}_I + \hat{H}_{R_c}]] \rangle_{\rho_{SR}},\end{aligned}\quad (31)$$

where the first term is the work cost to maintain the local collisions, while the second term originates from the simultaneous collisions of the system as whole with R_c . The thermodynamics consistence can be verified after obtaining the change of internal energy of the system

$$\begin{aligned}\Delta E_S &= \sum_{i=1}^N \left(\langle \hat{H}_{S_i} \rangle_{\rho'_{SR}} - \langle \hat{H}_{S_i} \rangle_{\rho_{SR}} \right) \\ &= -\frac{\tau}{2} \langle [\hat{H}_I, [\hat{H}_I, \hat{H}_S]] \rangle_{\rho_{SR}} - \frac{\tau}{2} \sum_{i=1}^N \langle [\hat{V}_i, [\hat{V}_i, \hat{H}_S]] \rangle_{\rho_{SR}},\end{aligned}\quad (32)$$

in the sense that the relation of $\Delta E_S = \Delta W + \Delta Q$ can always be fulfilled.

6. Conclusion

In conclusion, we have addressed effects of different types of interactions between a quantum system and thermal reservoirs on thermodynamical process, in particular the invested work and the operating regimes of the system as thermal machines. Specifically, we consider two subsystems interact independently with two local reservoirs and simultaneously with a common one. Within the framework of collision model, we construct the ME for the system's dynamics and formulate the thermodynamics quantities, i.e., the work, heat and system's internal energy, in their general forms. We demonstrate the results by focusing on the model of two coupled qubits and take three scenarios of collisions with the common reservoir into account, namely, the three-body one and two-body one with and without intrasystem interactions between subsystems. We show that not only the amounts but also the directions of work currents are closely related to the ways of collisions. As a consequence, distinct types of thermal machines, such as refrigerator, engine and accelerator, can be realized in these situations. We also discuss the efficiency or COP of the machines and show that though the machine with the same function can appear in different cases, which one is superior to the other is not fixed but related to control parameters. The type of system-reservoir interaction that can lead to the optimal performance of heat machine in given parameter regions could be used to design quantum heat machines with superiority over their classical counterparts. We finally generalize the bipartite model to the configuration with N subsystems and derive the corresponding formulations of thermodynamics quantities. Our results indicate that the interacting manner of system-reservoir is a significant factor in affecting thermodynamics process and one can choose suitable one to achieve thermodynamical task with required function and optimal efficiency.

Acknowledgments

This work was supported by the National Natural Science Foundation (China) under Grant No. 11974209, the Taishan Scholar Project of Shandong Province (China) under Grant No. tsqn201812059, and the Youth Technological Innovation Support Program of Shandong Provincial Colleges and Universities under Grant No. 2019KJ015.

Data availability statement

All data that support the findings of this study are included within the article (and any supplementary files).

ORCID iDs

Zhong-Xiao Man  <https://orcid.org/0000-0003-1906-5923>

Ying-Jie Zhang  <https://orcid.org/0000-0002-0603-8996>

References

- [1] Gemma G, Michel M and Mahler G 2004 *Quantum Thermodynamics* (Berlin: Springer)
- [2] Deffner S and Campbell S 2019 Quantum thermodynamics: an introduction to the thermodynamics of quantum information (arXiv:1907.01596v1)
- [3] Kosloff R 2013 Quantum thermodynamics: a dynamical viewpoint *Entropy* **15** 2100
- [4] Vinjanampathy S and Anders J 2016 Quantum thermodynamics *Contemp. Phys.* **57** 545
- [5] Goold J, Huber M, Riera A, del Rio L and Skrzypczyk P 2016 The role of quantum information in thermodynamics—a topical review *J. Phys. A: Math. Theor.* **49** 143001
- [6] Millen J and Xuereb A 2016 Perspective on quantum thermodynamics *New J. Phys.* **18** 011002
- [7] Breuer H and Petruccione F 2002 *The Theory of Open Quantum Systems* (Oxford: Oxford University Press)
- [8] Correa L A, Palao J P, Adesso G and Alonso D 2013 Performance bound for quantum absorption refrigerators *Phys. Rev. E* **87** 042131
- [9] González J O, Correa L A, Nocerino G, Palao J P, Alonso D and Adesso G 2017 Testing the validity of the ‘local’ and ‘global’ GKLS master equations on an exactly solvable model *Open Syst. Inf. Dyn.* **24** 1740010
- [10] Hofer P P, Perarnau-Llobet M, Miranda L D M, Haack G, Silva R, Brask J B and Brunner N 2017 Markovian master equations for quantum thermal machines: local versus global approach *New J. Phys.* **19** 123037
- [11] Mitchison M T and Plenio M B 2018 Non-additive dissipation in open quantum networks out of equilibrium *New J. Phys.* **20** 033005
- [12] Naseem M T, Xuereb A and Müstecaplıoğlu O E 2018 Thermodynamic consistency of the optomechanical master equation *Phys. Rev. A* **98** 052123
- [13] Cattaneo M, Giorgi G L, Maniscalco S and Zambrini R 2019 Local versus global master equation with common and separate baths: superiority of the global approach in partial secular approximation *New J. Phys.* **21** 113045
- [14] Scali S, Anders J and Correa L A 2020 Local master equations bypass the secular approximation (arXiv:2009.11324 [quant-ph])
- [15] Hewgill A, De Chiara G and Imperato A 2021 Quantum thermodynamically consistent local master equations *Phys. Rev. Research* **3** 013165
- [16] Stockburger J T and Motz T 2016 Thermodynamic deficiencies of some simple Lindblad operators *Fortschr. Phys.* **65** 1600067
- [17] Kołodźński J, Brask J B, Perarnau-Llobet M and Bylicka B 2018 Adding dynamical generators in quantum master equations *Phys. Rev. A* **97** 062124
- [18] Correa L A, Palao J P and Alonso D 2015 Internal dissipation and heat leaks in quantum thermodynamic cycles *Phys. Rev. E* **92** 032136
- [19] Levy A and Kosloff R 2014 The local approach to quantum transport may violate the second law of thermodynamics *Europhys. Lett.* **107** 20004
- [20] Purkayastha A, Dhar A and Kulkarni M 2016 Out-of-equilibrium open quantum systems: a comparison of approximate quantum master equation approaches with exact results *Phys. Rev. A* **93** 062114
- [21] Wichterich H, Henrich M J, Breuer H-P, Gemmer J and Michel M 2007 Modeling heat transport through completely positive maps *Phys. Rev. E* **76** 031115
- [22] De Chiara G, Landi G, Hewgill A, Reid B, Ferraro A, Roncaglia A J and Antezza M 2018 Reconciliation of quantum local master equations with thermodynamics *New J. Phys.* **20** 113024
- [23] Barra F 2015 The thermodynamic cost of driving quantum systems by their boundaries *Sci. Rep.* **5** 14873
- [24] Strasberg P, Schaller G, Brandes T and Esposito M 2017 Quantum and information thermodynamics: a unifying framework based on repeated interactions *Phys. Rev. X* **7** 021003
- [25] Guarnieri G, Morrone D, Çakmak B, Plastina F and Campbell S 2020 Non-equilibrium steady-states of memoryless quantum collision models *Phys. Lett. A* **384** 126576
- [26] Rau J 1963 Relaxation phenomena in spin and harmonic oscillator systems *Phys. Rev.* **129** 1880
- [27] Cattaneo M, De Chiara G, Maniscalco S, Zambrini R and Giorgi G L 2021 Collision models can efficiently simulate any multipartite Markovian quantum dynamics *Phys. Rev. Lett.* **126** 130403
- [28] Ziman M and Bužek V 2005 All (qubit) decoherences: complete characterization and physical implementation *Phys. Rev. A* **72** 022110
- [29] Benenti G and Palma G M 2007 Reversible and irreversible dynamics of a qubit interacting with a small environment *Phys. Rev. A* **75** 052110
- [30] Gennaro G, Benenti G and Palma G M 2009 Relaxation due to random collisions with a many-qudit environment *Phys. Rev. A* **79** 022105
- [31] Ciccarello F, Palma G M and Giovannetti V 2013 Collision-model-based approach to non-Markovian quantum dynamics *Phys. Rev. A* **87** 040103
- [32] Kretschmer S, Luoma K and Strunz W T 2016 Collision model for non-Markovian quantum dynamics *Phys. Rev. A* **94** 012106
- [33] Lorenzo S, Ciccarello F and Palma G M 2016 Class of exact memory-kernel master equations *Phys. Rev. A* **93** 052111
- [34] Bernardes N K, Carvalho A R R, Monk C H and Santos M F 2017 Coarse graining a non-Markovian collisional model *Phys. Rev. A* **95** 032117
- [35] Çakmak B, Pezzutto M, Paternostro M and Müstecaplıoğlu Ö E 2017 Non-Markovianity, coherence, and system-environment correlations in a long-range collision model *Phys. Rev. A* **96** 022109

- [36] Lorenzo S, Ciccarello F and Palma G M 2017 Composite quantum collision models *Phys. Rev. A* **96** 032107
- [37] Filippov S N, Piilo J, Maniscalco S and Ziman M 2017 Divisibility of quantum dynamical maps and collision models *Phys. Rev. A* **96** 032111
- [38] McCloskey R and Paternostro M 2014 Non-Markovianity and system-environment correlations in a microscopic collision model *Phys. Rev. A* **89** 052120
- [39] Bernardes N K, Carvalho A R R, Monk C H and Santos M F 2014 Environmental correlations and Markovian to non-Markovian transitions in collisional models *Phys. Rev. A* **90** 032111
- [40] Giovannetti V and Palma G M 2012 Master equations for correlated quantum channels *Phys. Rev. Lett.* **108** 040401
- [41] Jin J and Yu C-S 2018 Non-Markovianity in the collision model with environmental block *New J. Phys.* **20** 053026
- [42] Man Z X, Xia Y J and Lo Franco R 2018 Temperature effects on quantum non-Markovianity via collision models *Phys. Rev. A* **97** 062104
- [43] Lorenzo S, McCloskey R, Ciccarello F, Paternostro M and Palma G M 2015 Landauer's principle in multipartite open quantum system dynamics *Phys. Rev. Lett.* **115** 120403
- [44] Pezzutto M, Paternostro M and Omar Y 2016 Implications of non-Markovian quantum dynamics for the Landauer bound *New J. Phys.* **18** 123018
- [45] Karevski D and Platini T 2009 Quantum nonequilibrium steady states induced by repeated interactions *Phys. Rev. Lett.* **102** 207207
- [46] Barra F and Lledó C 2017 Stochastic thermodynamics of quantum maps with and without equilibrium *Phys. Rev. E* **96** 052114
- [47] Cusumano S, Cavina V, Keck M, De Pasquale A and Giovannetti V 2018 Entropy production and asymptotic factorization via thermalization: a collisional model approach *Phys. Rev. A* **98** 032119
- [48] Seah S, Nimmrichter S and Scarani V 2019 Nonequilibrium dynamics with finite-time repeated interactions *Phys. Rev. E* **99** 042103
- [49] Arisoy O, Campbell S and Müstecaplıođlu Ö E 2019 Thermalization of finite many-body systems by a collision model *Entropy* **21** 1182
- [50] Manatuly A, Niedenzu W, Román-Ancheyta R, Çakmak B, Müstecaplıođlu Ö E and Kurizki G 2019 Collectively enhanced thermalization via multiqubit collisions *Phys. Rev. E* **99** 042145
- [51] Landi G T, Novais E, de Oliveira M J and Karevski D 2014 Flux rectification in the quantum xxz chain *Phys. Rev. E* **90** 042142
- [52] Seah S, Nimmrichter S, Grimmer D, Santos J P, Scarani V and Landi G T 2019 Collisional quantum thermometry *Phys. Rev. Lett.* **123** 180602
- [53] Barra F 2019 Dissipative charging of a quantum battery *Phys. Rev. Lett.* **122** 210601
- [54] Dađ C B, Niedenzu W, Müstecaplıođlu Ö E and Kurizki G 2016 Multiatom quantum coherences in micromasers as fuel for thermal and nonthermal machines *Entropy* **18** 244
- [55] Pezzutto M, Paternostro M and Omar Y 2019 An out-of-equilibrium non-Markovian quantum heat engine *Quantum Sci. Technol.* **4** 025002
- [56] Hewgill A, González J O, Palao J P, Alonso D, Ferraro A and De Chiara G 2020 Three-qubit refrigerator with two-body interactions *Phys. Rev. E* **101** 012109
- [57] De Chiara G and Antezza M 2020 Quantum machines powered by correlated baths *Phys. Rev. Res.* **2** 033315
- [58] Rodrigues F L S, De Chiara G, Paternostro M and Landi G T 2019 Thermodynamics of weakly coherent collisional models *Phys. Rev. Lett.* **123** 140601
- [59] Leitch H, Piccione N, Bellomo B and Chiara G D 2022 Driven quantum harmonic oscillators: a working medium for thermal machines (arXiv:2108.11341v2)
- [60] Tonner F and Mahler G 2005 Autonomous quantum thermodynamic machines *Phys. Rev. E* **72** 066118
- [61] Roulet A, Nimmrichter S, Arrazola J M, Seah S and Scarani V 2017 Autonomous rotor heat engine *Phys. Rev. E* **95** 062131
- [62] Niedenzu W, Huber M and Boukobza E 2019 Concepts of work in autonomous quantum heat engines *Quantum* **3** 195
- [63] Buffoni L, Solfanelli A, Verrucchi P, Cuccoli A and Campisi M 2019 Quantum measurement cooling *Phys. Rev. Lett.* **122** 070603
- [64] Chen Y-X and Li S-W 2012 Quantum refrigerator driven by current noise *Europhys. Lett.* **97** 40003
- [65] Hofer P P, Souquet J-R and Clerk A A 2016 Quantum heat engine based on photon-assisted cooper pair tunneling *Phys. Rev. B* **93** 041418
- [66] Hofer P P, Perarnau-Llobet M, Brask J B, Silva R, Huber M and Brunner N 2016 Autonomous quantum refrigerator in a circuit QED architecture based on a Josephson junction *Phys. Rev. B* **94** 235420
- [67] Cottet N et al 2017 Observing a quantum Maxwell demon at work *Proc. Natl Acad. Sci. USA* **114** 7561
- [68] Koski J V, Sagawa T, Saira O P, Yoon Y, Kutvonen A, Solinas P, Mottonen M, Ala-Nissila T and Pekola J P 2013 Distribution of entropy production in a single-electron box *Nat. Phys.* **9** 644
- [69] Koski J V, Maisi V F, Pekola J P and Averin D V 2014 Experimental realization of a Szilard engine with a single electron *Proc. Natl Acad. Sci. USA* **111** 13786
- [70] Jukka P 2015 Pekola towards quantum thermodynamics in electronic circuits *Nat. Phys.* **11** 118
- [71] Manucharyan V E 2012 Superinductance *PhD Thesis* Yale University
- [72] Chen Y et al 2014 Qubit architecture with high coherence and fast tunable coupling *Phys. Rev. Lett.* **113** 220502
- [73] Chen Y X and Li S W 2011 Quantum refrigerator driven by current noise *Europhys. Lett.* **97** 40003
- [74] Pachos J K and Rico E 2004 Effective three-body interactions in triangular optical lattices *Phys. Rev. A* **70** 053620