

QUANTUM SPIN CHAINS WITH LATTICE
SUPERSYMMETRY

by

Junye Yang

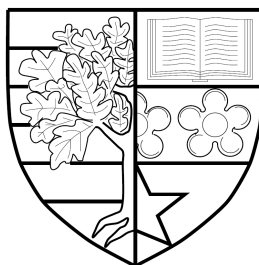

Submitted for the degree of
Doctor of Philosophy

DEPARTMENT OF MATHEMATICAL SCIENCE
SCHOOL OF MATHEMATICAL AND COMPUTER SCIENCES
HERIOT-WATT UNIVERSITY

September 2017

The copyright in this thesis is owned by the author. Any quotation from the report or use of any of the information contained in it must acknowledge this report as the source of the quotation or information.

Abstract

This thesis has studied spin chains with Lattice supersymmetry. Connections have been found between Lattice supersymmetry and integrability. In particular, the construction of lattice supercharge has been incorporated into the construction of the quantum inverse scattering method. The open XXZ chain Hamiltonian has been studied, and the construction of the supersymmetric open XXZ chain Hamiltonian by C.Hagendorf and J.Liénardy has been extended. The integrable open XXZ chain Hamiltonian with generic boundary matrices has been studied using TQ equations proposed by W.Yang, R.I.Nepomechie and Y.Zhang, and the integrable open XXZ chain Hamiltonian with diagonal boundary matrices has been studied using the algebraic Bethe ansatz developed by E.K.Sklyanin. For these two types of Hamiltonians, conditions on the boundary parameters have been found where Hamiltonians will have a symmetry in their Bethe equations. This symmetry induces a map S^{Bethe} , which shares certain properties with the lattice supercharge S_N . An open XXZ chain Hamiltonian has been found which has symmetry with respect to both S_N and S^{Bethe} . This Hamiltonian is denoted as $H_{XXZ,diagonal}^{(N)}$. Using the numerical method developed by B.McCoy, the action of the map S^{Bethe} of $H_{XXZ,diagonal}^{(N)}$ has been calculated, and the result has confirmed numerically that S^{Bethe} is proportional to the lattice supercharge S_N . Motivated by this connection, a family of commutation relations between the lattice supercharge of $H_{XXZ,diagonal}^{(N)}$ and sub-matrices of the monodromy matrix corresponding to $H_{XXZ,diagonal}^{(N)}$ have been found and proved using diagrammatic method. Similar commutation relations have also been obtained for the open XXZ chain Hamiltonian with anti-diagonal boundary matrices.

Acknowledgements

Thanks to Robert for his patience. I have learned a lot from him, and we have encountered some beautiful results in Mathematics and Physics. Without his guidance and input, this thesis would not be here. And thanks to Des for many useful discussions.

Thanks to Hélder, Vera, Carla, Ranty, Jelle, Etienne, Yin, Louis, José, Jesus, Pablo, Mark, Edgar, Kate, Yvo, Andrew, Jakub, Donny, Emma, Sergio, Iain, Houry, Chao, Jennifer, James, Edi, Samuel, Bonnah, Marie, Jovan, Eny, Maggie, Aoife, Mathew, Lara, Nuri, Lizzi, Mari, Manu, Anya, David, Zhaoxun, Jiaqi for good company, I hope we can meet again.

Special thanks to Miao and my parents for believing in me.

Thanks to Edinburgh and its people for being so awesome, it is like a second home.

Contents

1	Introduction	1
2	Spin Chain and Lattice Supersymmetry	8
2.1	Lattice Supersymmetry of Closed Chains	10
2.2	Lattice Supersymmetry of Open Chain	14
2.3	The General Solutions for The Local Supercharge	18
3	The Bethe Ansatz for Vertex Models	26
3.1	Vertex Model	27
3.2	Yang-Baxter Equation and Integrability	30
3.3	The Algebraic Bethe Ansatz for Periodic Boundary Condition	37
3.4	The Algebraic Bethe Ansatz for Open Boundary Conditions	42
3.5	TQ equations and Baxter's Q-operator	54
3.5.1	Fusion Hierarchy	55
3.5.2	TQ equation	57
4	Symmetry of Bethe equations	61

4.1	Bethe Ansatz analysis on closed chain	63
4.2	The Open Chain with Non-diagonal Boundary Matrices	64
4.3	Open Chain with Diagonal Boundary Matrices	70
4.4	The Map S^{Bethe} and The Lattice Supercharge	73
4.4.1	McCoy's Method	74
4.4.2	Direct Diagonalisation	76
5	Integrability and Lattice Supersymmetry	79
5.1	Lattice Supersymmetry	80
5.2	The Algebraic Bethe Ansatz and Lattice Supersymmetry	82
5.3	SUSY on open chain	105
6	Conclusion and Future Work	111
	Bibliography	114

Chapter 1

Introduction

Quantum spin chains are a class of very important models in statistical physics. They incorporate concepts in diverse areas of mathematics, such as the representation theory of quantum groups, integrable systems and combinatorics. They can also be applied to a wide range of phenomena including solid state physics, models of superconductivity, and non-linear optics. This introduction will give a brief review of two types of models which are connected to quantum spin chains. The first type of models is integrable vertex models, and the other type of models is supersymmetric lattice models. At the end of the introduction, a layout of the thesis will be presented which will include novel results on how to connect these two models in the language of the algebraic Bethe ansatz.

The first step towards the solution of the spectral problem of quantum spin chains was accomplished in [1], which studied the XXX spin chain. This method is called the coordinate Bethe ansatz. In the context, the word ansatz can be understood as making certain assumption about the solution, and then carrying out calculation under this assumption to verify it. In the coordinate Bethe ansatz, the assumption is about the coefficients of the eigenstates in the coordinate space. The coefficients involve certain number of parameters which depend on the down spin in the eigenstate. These parameters are called Bethe roots. The conditions where the states with these coefficients become eigenstates are called Bethe equations.

This method has been generalised to the XXZ chain in [2] [3] [4], and to the XYZ chain in [5] [6] [7] [8] [9]. The connection of vertex models and spin chains was first pointed out by Lieb for the six-vertex model and the XXZ chain in [10] [11] [12] [13], and later developed by Baxter for the eight-vertex model and the XYZ chain in [5] [6]. The method can also be applied to other quantum mechanical systems, e.g. Heisenberg spin chains, the one-dimensional Bose gas with point interactions and the massive Thirring model. However, it offers little help for the calculation of correlation functions of the model. A more transparent version of this method is developed later in [14] [15] [16] [17] [18] [19] [20]. A comprehensive review can be found in [21]. This method is called the algebraic Bethe ansatz, and it motivated the study of quantum groups [22]. Rather than working on the coordinate space, the eigenstate is assumed to be created from a certain reference state by actions of a creation operator, and the number of creation operators is related to the number of down spins in the eigenstate. The parameters in the creation operators are called the Bethe roots. When the anisotropy parameter of the XXZ chain Hamiltonian $\cosh \eta$ takes generic values, this method will give all the eigenstates. However, when η are roots of unity, certain solutions of Bethe equations will lead to the vanishing of creation operators. In the six-vertex model, the complete algebraic Bethe ansatz is given in [23] with the help of the sl_2 symmetry of the model. The complete algebraic Bethe ansatz of the eight-vertex model is given in [24]. The algebraic Bethe ansatz has been generalised to open boundary conditions in [25]. In [26] [27] [28] [29] [30] [31], a special correlation function of the spin-half XXZ chain named the emptiness formation probability is calculated using the algebraic Bethe ansatz. The emptiness formation probability of the first m sites has been expressed in a formula which is closely related to the number of $m \times m$ alternating sign matrices when $\cosh(\eta) = -\frac{1}{2}$. Connections with alternating sign matrices also arise in supersymmetric lattice models. A review article of results on correlation function can be found in [32].

There are other methods developed for quantum spin chains. The analytic Bethe ansatz is developed in [33]. In this method, the eigenvalue is written out in a certain

form involving additional parameters. The properties of the eigenvalue imply certain conditions on these parameters, and these conditions are Bethe equations. The eigenstate can not be constructed using this method. The Q -operator and TQ equations were first developed by Baxter [34] [5] [7] [8] [9] to solve the spectral problem of the eight-vertex model. This is a model where the standard algebraic Bethe ansatz is difficult to apply. The Q -operator method relies on the existence of a certain matrix named the Q -operator which satisfies certain functional relations with the transfer matrix. These functional relations imply a relation between the eigenvalues of the transfer matrix and the Q -operator. The eigenvalue of the Q -operator is a polynomial in the spectral parameter u , and the roots of this polynomial are named Bethe roots. However, this method can not give the construction of the eigenstates. A review on TQ equations can be found in [35]. Since then, there has been a lot of work devoted to the Q -operator and its relation to the representation theory of quantum groups. In [36] [37] [38], TQ equations of the six-vertex model has been obtained using the q -oscillator representation of $U_q(\widehat{sl}_2)$. In [39] [40] [41], motivated by the study of integrable conformal field theory [42] [43] [44], a fundamental functional relation was obtained also using the representation theory of $U_q(\widehat{sl}_2)$, and the TQ equations and fusion hierarchy can also be obtained from this fundamental relation. The construction of Q -operator in [39] has been generalised in [45] [46]. The vertex operator approach is developed to calculate the correlation functions, which works at the thermodynamic limit of spin chains instead of spin chains with finite length. A review of this approach can be found in [47].

The supersymmetric lattice fermion model M_1 was first defined in [48]. This model is one-dimensional, with a single species of fermions. The Hamiltonian of this model can be constructed from a lattice supercharge, which is constructed from the fermion creation and annihilation operators. The fermions satisfy the usual anti-commutation rule together with the restriction that fermions can not sit on neighbouring sites. This type of fermions is named hard core fermions. This model is related to a $\mathcal{N} = 2$ super-conformal field theory with central charge $c = 1$, and it is among the first which has an explicit construction in terms of a lattice supercharge.

The generalised lattice fermion models M_k are defined in [49], where only up to k consecutive lattice sites maybe occupied. In [50], the map between the M_1 model and the spin-half XXZ spin chain is established. Using this map, it has been shown that the spin-half XXZ chain at $\eta = \frac{2i\pi}{3}$ is supersymmetric. The lattice supercharge S_N of the spin-half XXZ spin chain Hamiltonian can also be derived from the lattice supercharges of the M_1 model. In [51], the XXX chain has been shown to have lattice supersymmetry. In [52], the XYZ chain has been proven to be supersymmetric on a one-dimensional parameter space, which includes the spin-half XXZ chain at $\eta = \frac{2i\pi}{3}$ as a special case. The supersymmetry is also manifest in the coordinate Bethe ansatz of the supersymmetric XYZ chain as pairing of Bethe roots [53].

An important feature of both the M_1 model and the spin-half XXZ chain at $\eta = \frac{2i\pi}{3}$ is that their ground states exhibit interesting combinatorial properties. The components of the ground state of the supersymmetric spin-half XXZ chain are related to the enumeration of alternating sign matrix [54] [55] [56]. Using the map between the spin-half XXZ chain and the $O(1)$ loop model, the components of the ground state are related to the enumeration of the fully packed loops. The connection with the $O(1)$ loop model also enables the use of powerful techniques such as the quantum Knizhnik-Zamolodchikov equation [57] [58] [59] [60] [61] and combinatorial methods using dihedral symmetry [62] [63]. The relation between quantum spin chains and combinatorics can also be extended to higher spin cases. In [64], the supersymmetric spin-one XXZ chain has been studied. The ground state of this model also exhibits interesting combinatorial properties, which have been further studied in [65] [66]. In [67], the supersymmetric spin-half XXZ chain with open boundary condition has been studied. The ground state of this model has been used to calculate an entanglement measure called the bipartite fidelity [68].

Since the connection between supersymmetric models and integrable spin chains has been pointed out in [50], research has been done to understand the relation between the lattice supersymmetry and integrability. In [69], all homogeneous rational and trigonometric $gl(n|m)$ spin chains with periodic boundary condition have been

studied. Using their Bethe equations, the spin chains with lattice supersymmetry are identified. In [70], the supercharge of the M_2 model has been constructed explicitly. The supersymmetry of this model can also be implied from the symmetry of the Bethe equations which will induce a map taking a set of Bethe roots on the spin chain of length N to another set of Bethe roots with a extra root on the spin chain of length $N - 1$. This map can be identified with the lattice supercharge of the M_2 model. This thesis will continue this direction of research. Connections will be developed between the lattice supersymmetry and the integrability of the XXZ chain with diagonal boundary matrices. Instead of using the coordinate Bethe ansatz as in [70], the algebraic Bethe ansatz will be used, and the lattice supercharge will be incorporated into it.

In Chapter 2, the idea of lattice supersymmetry will be introduced, and the constructions of integrable supersymmetric Hamiltonians for the periodic boundary condition [52] and the open boundary condition [67] will also be introduced. In Section 2.3, the construction of the local supercharge in [67] has been extended, which is a new result. This extension relies on the use of Maple software to solve polynomial equations with integer coefficients. The extended supersymmetric Hamiltonian is equal to the spin-half open XXZ chain Hamiltonian at $\eta = \frac{2i\pi}{3}$. With this connection, the supersymmetric Hamiltonian can be analysed using the Algebraic Bethe ansatz and TQ equations, which will be introduced in Chapter 3.

In Chapter 4, the idea of the Bethe ansatz symmetry will be introduced, from which it follows that there is a pairing of Bethe roots of Hamiltonians with different sizes. This idea has first been used in [52], and it works when $\eta = \frac{2i\pi}{3}$ for both the periodic and the open boundary conditions. In the periodic case, the Bethe ansatz symmetry only appears in a special sub-space. The analysis of Bethe equations in the open case has first been done in this thesis. The analysis is simplified comparing with the periodic case, since the Bethe ansatz symmetry exists on the whole space. In general, this symmetry induces an operator S_N^{Bethe} which takes an eigenstate of the Hamiltonian of size N with a set of Bethe roots $\{\lambda_1, \dots, \lambda_M\}$, to an eigenstate of

the Hamiltonian of size $N - 1$ with a set of Bethe roots $\{\lambda_1, \dots, \lambda_M, (s + \frac{1}{2})\eta\}$, where s is the spin. Another property of S_N^{Bethe} is that the two eigenstates connected by S_N^{Bethe} have the same eigenvalues with respect to a properly normalised Hamiltonian. In Section 4.4, a special spin-half open XXZ Hamiltonian with diagonal boundary matrices is studied; This Hamiltonian will be denoted as $H_{XXZ,diagonal}^{(N)}$, and it has already been studied in [50] [67]. This Hamiltonian is integrable and has lattice supersymmetry. The study of this Hamiltonian will offer certain insight into the relation between the lattice supercharge S_N and the operator S^{Bethe} , which is new to the literature.

In Chapter 5, with all the preparation done, the main results of this thesis will be introduced. The materials in Section 5.2 and Section 5.3 are new to the literature. In Section 4.4, it has been checked numerically that $S_N \propto S_N^{Bethe}$ for $H_{XXZ,diagonal}^{(N)}$. This suggests the algebraic Bethe ansatz and lattice supercharge are related as in [70]. However, this connection does not end here: the following relations have also been found

$$S_N B_N(u) \propto B_{N-1}(u) S_N,$$

$$S_N \Omega_N \propto B_{N-1}(\eta) \Omega_{N-1},$$

where u is any complex number and Ω_N is the reference state in the algebraic Bethe ansatz. The large part of Chapter 5 is dedicated to the proof of these relations, and the exact ratio of the left hand side and right hand side of the above two relations will be found. These relations gives a certain insight into how lattice supersymmetry arises in the context of quantum integrability. By using an diagrammatic argument, it becomes clear that the relation $S_N B_N(u) \propto B_{N-1}(u) S_N$ is only one among a family of commutation relations. One of the relations within this family is $S_N t_N(u) \propto t_{N-1}(u) S_N$, which is consistent with the commutativity between the lattice supercharge S_N and the Hamiltonian $H_{XXZ,diagonal}^{(N)}$. The results in Section 5.1 and Section 5.2 can be found in [71]. At the end of this chapter, a Hamiltonian with anti-diagonal boundary matrices is constructed. This Hamiltonian is exactly the one studied in [67] at $\theta = 0$ and $\rho = 1$. It also has both the lattice supersym-

metry and the map S^{Bethe} . Although the algebraic Bethe ansatz does not apply to this Hamiltonian, relation $S_N t_N(u) \propto t_{N-1}(u) S_N$ is still true. From this relation, a family of commutation relations can be derived.

Chapter 2

Spin Chain and Lattice

Supersymmetry

In this chapter, quantum spin chains with lattice supersymmetry will be introduced. Supersymmetric quantum mechanics has been defined in [72]. In the simplest case the Hamiltonian H is defined as the square of a supercharge Q

$$H = Q^2,$$

where H and Q are finite hermitian matrices. It is important to notice that the eigenstates of non-zero energy always come in pairs. Let $|\phi\rangle$ be any eigenstate with eigenvalue E , then $Q|\phi\rangle$ is also an eigenstate with eigenvalue E . This is because

$$HQ|\phi\rangle = Q^3|\phi\rangle = QH|\phi\rangle = EQ|\phi\rangle.$$

The action of Q on the state $Q|\phi\rangle$ is $Q^2|\phi\rangle = E|\phi\rangle$, which is proportional to $|\phi\rangle$. Another important fact which can be derived from the form of H is that all eigenvalues are non-negative. To see this, recall that Q is a finite hermitian matrix, and the finite-dimensional spectral theorem implies that it is diagonalisable by a unitary matrix and have real eigenvalues. Hence the eigenvalues of H are square of the eigenvalues of Q . It also follows that the zero-energy state is annihilated by Q .

In supersymmetric quantum mechanics, there are two types of eigenstates, they are called fermions and bosons. The supercharge takes fermions to bosons, and bosons to fermions. Let a boson with energy E be denoted as $|b\rangle$, and define a fermion as $|f\rangle = \frac{Q|b\rangle}{\sqrt{E}}$. The action of Q on them are given by

$$Q|b\rangle = \sqrt{E}|f\rangle, Q|f\rangle = \sqrt{E}|b\rangle.$$

When the energy is zero, Q will annihilate both $|b\rangle$ and $|f\rangle$. A pair consisting of a boson and fermion with non-zero energy will be called a supersymmetric doublets, and unpaired bosons and fermions with zero-energy will be called the supersymmetric singlets. These two types of particles can be distinguished by the operator $(-1)^F$. The action of $(-1)^F$ will be defined as

$$(-1)^F|b\rangle = |b\rangle, (-1)^F|f\rangle = -|f\rangle.$$

The trace of the operator $(-1)^F$ will be called the Witten index, and will be denoted as $Tr(-1)^F$. Since all bosons contribute $+1$ and all fermions contribute -1 , the contribution of supersymmetric doublets to $Tr(-1)^F$ is zero. The value of the Witten index is the difference of the number of zero-energy bosons and zero-energy fermions.

A necessary condition for the existence of supersymmetry is the existence of zero-energy states, i.e. supersymmetric singlets. The Witten index is a reliable indicator of supersymmetry, since it is invariant under small change in parameters of the model. When the Witten index is non-zero, the supersymmetry is not spontaneously broken. When it is zero, the supersymmetry may or may not be broken.

The supersymmetric Hamiltonian of the XYZ chain on the lattice has a slightly different construction. First, the Hilbert space is the direct sum of those of finite lattices of all lengths. The Hamiltonian is defined individually on every finite lattice, and the one on the lattice of length N will be denoted as $H_{XYZ}^{(N)}$. Second, the construction of the Hamiltonian $H_{XYZ}^{(N)}$ involves two conjugate supercharges S_N :

$V^{\otimes N} \rightarrow V^{\otimes N-1}$ and $S_N^\dagger : V^{\otimes N-1} \rightarrow V^{\otimes N}$. These supercharges will change the length of the states, hence this type of supersymmetry on the lattice is often called the dynamical lattice supersymmetry. Finally, the supercharges are nilpotent, i.e. $S_{N-1}S_N = S_{N+1}^\dagger S_N^\dagger = 0$. The Hamiltonian is defined as

$$H_{XYZ}^{(N)} = S_{N+1}S_{N+1}^\dagger + S_N^\dagger S_N.$$

The nilpotency implies the commutativity of the Hamiltonian and the supercharges. This is because

$$\begin{aligned} S_N H_{XYZ}^{(N)} &= S_N S_{N+1} S_{N+1}^\dagger + S_N S_N^\dagger S_N \\ &= S_N S_N^\dagger S_N + S_{N-1}^\dagger S_{N-1} S_N = H_{XYZ}^{(N-1)} S_N. \end{aligned}$$

This commutativity is essential for the existence of features of supersymmetric quantum mechanics such as the pairing of bosons and fermions.

From now on, the word supersymmetry will be abbreviated as SUSY. In Section 2.1, the supersymmetric spin-half XYZ chain of the periodic boundary condition in [52] will be defined. The properties of this Hamiltonian will be studied. In Section 2.2, the construction in Section 2.1 will be generalised to the open boundary condition. This work is due to C.Hagendorf and J.Liénardy [67], and it focuses on the XXZ chain. In Section 2.3, the results in Section 2.2 will be further generalised. This work is due to the author.

2.1 Lattice Supersymmetry of Closed Chains

This section will study the spin-half XYZ Hamiltonian

$$H_{XYZ}^{(N)} = -\frac{1}{2} \sum_{j=1}^N (J_x \sigma_j^x \sigma_{j+1}^x + J_y \sigma_j^y \sigma_{j+1}^y + J_z \sigma_j^z \sigma_{j+1}^z) + \frac{N(J_x + J_y + J_z)}{2} \mathbb{I}, \quad (2.1)$$

with periodic boundary conditions, i.e, $\sigma_{N+i}^\alpha \equiv \sigma_i^\alpha$, and the restriction

$$J_x J_y + J_y J_z + J_x J_z = 0.$$

There exists a parametrisation of parameters in the Hamiltonian (2.1) by ζ

$$\begin{cases} J_x = 1 + \zeta, \\ J_y = 1 - \zeta, \\ J_z = (\zeta^2 - 1)/2. \end{cases}$$

In a certain subspace, this Hamiltonian with odd N has a constant ground state for varying $\zeta \in \mathbb{R}$ [52]. The origin of this phenomenon will become clear after the study of lattice SUSY of this Hamiltonian.

Motivated by the lattice fermion model, a length changing operator is needed as the supercharge of $H_{XYZ}^{(N)}$, and it can be constructed from some local length changing operator p

$$p : V \otimes V \rightarrow V,$$

where $V = \mathbb{C}v_+ + \mathbb{C}v_- \simeq \mathbb{C}^2$, with basis elements as

$$v_+ = \begin{bmatrix} 1 \\ 0 \end{bmatrix}, v_- = \begin{bmatrix} 0 \\ 1 \end{bmatrix}.$$

The notations (+) and (−) will also be used for v_+ and v_- later in diagrams. It is easy to define the conjugation of p

$$p^\dagger = \begin{bmatrix} 0 & 1 \\ 0 & 0 \\ 0 & 0 \\ 0 & -\zeta \end{bmatrix}.$$

The conjugate of the local supercharge acting on the i th site is denoted as p_i^\dagger . The

local supercharge p at site j is

$$p_j \equiv (p_j^\dagger)^\dagger.$$

Since the spin chain has the periodic boundary condition, a local operator is needed which will act on the first and the last site at the same time. It will be denoted as p_0 . In [52], the conjugate of p_0 is defined as

$$p_0^\dagger = T_{N+1} p_N^\dagger.$$

The translation operator T_N is defined as

$$T_N |\alpha_1, \dots, \alpha_N\rangle = |\alpha_N, \alpha_1, \dots, \alpha_{N-1}\rangle,$$

where $\{\alpha_1, \dots, \alpha_N\} \in \{+, -\}$ and $|\alpha_1, \dots, \alpha_N\rangle \equiv \alpha_1 \otimes \dots \otimes \alpha_N \in V^{\otimes N}$. The expression of p_0 in the term of p_N is different from the relation (8) in [52]. This is because the definition of p_i in this thesis is equal to $(-1)^{i+1} p_i^\dagger$ in [52]. The lattice supercharge S_N is a map

$$S_N : V^{\otimes N} \rightarrow V^{\otimes N-1}.$$

Using the local supercharge, S_N^\dagger is defined in terms of p_i^\dagger and a projection $P^{(N)}$ onto a subspace of $V^{\otimes N}$. This subspace is the eigenspace of the translation operator T_N with the eigenvalue $(-1)^{N+1}$. The value of S_N^\dagger on this subspace is then defined by

$$S_N^\dagger = \left[\left(\frac{N-1}{N} \right)^{1/2} \sum_{j=0, \dots, N-1} (-1)^{j-1} p_j^\dagger \right] P^{(N)}.$$

S_N is defined as $S_N = (S_N^\dagger)^\dagger$. It has been proved in [52] that

$$H_{XYZ}^{(N)} = S_{N+1} S_{N+1}^\dagger + S_N^\dagger S_N,$$

and

$$S_{N+1}^\dagger S_N^\dagger = 0.$$

The Hamiltonian $H_{XYZ}^{(N)}$ has certain features of supersymmetric quantum me-

chanics. Let $|\phi\rangle$ be an eigenstate of $H_{XYZ}^{(N)}$ with the eigenvalue E . Then $|\phi\rangle$ has the property

$$\langle\phi|H_{XYZ}^{(N)}|\phi\rangle = \langle\phi|E|\phi\rangle = E\|\phi\|^2 = \left\|S_{N+1}^\dagger|\phi\rangle\right\|^2 + \|S_N|\phi\rangle\|^2. \quad (2.2)$$

Hence $E \geq 0$. From the nilpotency property, it follows that

$$\begin{aligned} S_{N+1}^\dagger H_{XYZ}^{(N)} &= S_{N+1}^\dagger S_{N+1} S_{N+1}^\dagger + S_{N+1}^\dagger S_N^\dagger S_N \\ &= S_{N+2} S_{N+2}^\dagger S_{N+1}^\dagger + S_{N+1}^\dagger S_{N+1} S_{N+1}^\dagger = H_{XYZ}^{(N+1)} S_{N+1}^\dagger. \end{aligned}$$

This implies that $S_{N+1}^\dagger|\phi\rangle$ is also an eigenstate of $H_{XYZ}^{(N+1)}$ with the eigenvalue E , and $S_N|\phi\rangle$ is an eigenstate of $H_{XYZ}^{(N-1)}$ with the eigenvalue E . It has also been proved in [52] that for $E > 0$ one and only one of $S_{N+1}^\dagger|\phi\rangle$ and $S_N|\phi\rangle$ must vanish, and for $E = 0$, both $S_{N+1}^\dagger|\phi\rangle$ and $S_N|\phi\rangle$ will vanish.

To see this, let $H_{XYZ}^{(N)} = H_1^{(N)} + H_2^{(N)}$, where $H_1^{(N)} = S_{N+1} S_{N+1}^\dagger$ and $H_2^{(N)} = S_N^\dagger S_N$. It is worth noting that $H_{XYZ}^{(N)}$, $H_1^{(N)}$ and $H_2^{(N)}$ are all hermitian, and $H_{XYZ}^{(N)}$ commutes with $H_1^{(N)}$ and $H_2^{(N)}$. By the finite-dimensional spectral theorem, hermitian matrices are diagonalisable. A set of diagonalisable matrices commutes if and only if the set is simultaneously diagonalisable. Hence $H_{XYZ}^{(N)}$, $H_1^{(N)}$ and $H_2^{(N)}$ are simultaneously diagonalisable, and they share the same eigenstates. Let $|\phi\rangle$ be a common eigenstate of $H_{XYZ}^{(N)}$ with positive eigenvalue, from the same argument used in relation (2.2), the sum of eigenvalues of $|\phi\rangle$ with respect to $H_1^{(N)}$ and $H_2^{(N)}$ have to be positive. Hence one of the eigenvalues of $|\phi\rangle$ with respect to $H_1^{(N)}$ and $H_2^{(N)}$ has also to be positive. There are two cases. In the first case, $|\phi\rangle$ is eigenstate with positive energy E for $H_1^{(N)}$. Since $H_2^{(N)} H_1^{(N)} = 0$, it follows that $H_2^{(N)}|\phi\rangle = \frac{1}{E} H_2^{(N)} H_1^{(N)}|\phi\rangle = 0$, i.e., $S_N^\dagger S_N|\phi\rangle = 0$. This implies that $|\phi\rangle$ is an eigenstate of $H_{XYZ}^{(N)}$ with eigenvalue $E > 0$. Projecting $|\phi\rangle$ on $S_N^\dagger S_N|\phi\rangle$ will give $\|S_N|\phi\rangle\|^2 = 0$, hence $S_N|\phi\rangle = 0$. However, $S_{N+1}^\dagger|\phi\rangle \neq 0$, since otherwise $H_1^{(N)}|\phi\rangle = 0$ which contradict $E > 0$. In the second case, $|\phi\rangle$ is eigenstate with positive energy E for $H_2^{(N)}$. It follows from the same argument that $|\phi\rangle$ is an eigenstate

of $H_{XYZ}^{(N)}$ with eigenvalue $E > 0$, and $S_{N+1}^\dagger |\phi\rangle = 0$ and $S_N |\phi\rangle \neq 0$.

Hence every eigenstate with positive energy is part of the pair

$$(|\phi\rangle, S_{N+1}^\dagger |\phi\rangle),$$

or the pair

$$(S_N |\phi\rangle, |\phi\rangle).$$

These pairs will be called the supersymmetric doublets.

In the case where $|\phi\rangle$ is a zero-energy state for $H_{XYZ}^{(N)}$, it is easy to see from relation (2.2) that $\|S_{N+1}^\dagger |\phi\rangle\|^2 = 0$ and $\|S_N |\phi\rangle\|^2 = 0$. Hence any zero-energy state of $H_{XYZ}^{(N)}$ has to be annihilated by both S_N and S_{N+1}^\dagger . The zero-energy state will be called the supersymmetric singlet. Hence $H_{XYZ}^{(N)}$ has some features of a supersymmetric quantum mechanics. The Hamiltonian with these features will be called supersymmetric, or be said to possess lattice SUSY. Hence $H_{XYZ}^{(N)}$ has lattice SUSY.

2.2 Lattice Supersymmetry of Open Chain

With open boundary conditions, the construction of the supersymmetric Hamiltonian is simplified. The reason for this simplification lies in the fact that the lattice supercharge is no longer restricted to a certain subspace as in the periodic case. There is also no need to define p_0 in the open boundary condition case. As in the periodic case, p is a map

$$p : V \otimes V \rightarrow V,$$

There exists a local supercharge p which induces the supersymmetric spin-half XXZ chain Hamiltonian is given in [67]

$$p = x \begin{bmatrix} -2y & -y^2 & -y^2 & y^3 \\ 1 & -y & -y & -2y^2 \end{bmatrix}, \quad (2.3)$$

where $x = (1 + |y|^6)^{-\frac{1}{2}}$ and $y \in \mathbb{C}$. From the local supercharge p , the lattice supercharge will be constructed as

$$S_N = \sum_{i=1}^{N-1} (-1)^{i+1} p_i, \quad (2.4)$$

where p_i is acting on the i th and $i + 1$ th sites. In [67], it has been proved that the p in the relation (2.3) satisfies

$$p(I \otimes p) = p(p \otimes I).$$

The nilpotency condition $S_{N-1}S_N = 0$ is a direct consequence of this property of p . This is because

$$S_{N-1}S_N = \sum_{i=1}^{N-2} (-1)^{i+1} p_i \sum_{j=1}^{N-1} (-1)^{j+1} p_j = \sum_{i=1}^{N-2} \sum_{j=1}^{N-1} (-1)^{i+j} p_i p_j,$$

Since p_i and p_j does not interact for all i except $i = j$ and $i = j - 1$, it follows that

$$\begin{aligned} S_{N-1}S_N &= p_1 p_1 + \sum_{j=2}^{N-2} ((-1)^{2j-1} p_{j-1} p_j + (-1)^{2j} p_j p_j) - p_{N-2} p_{N-1} \\ &= \sum_{i=1}^{N-2} (p_i p_i - p_i p_{i+1}). \end{aligned}$$

It is easy to see that $p_i p_i - p_i p_{i+1}$ is $p(I \otimes p) - p(p \otimes I)$ on the i th to the $i + 1$ th sites. Hence $p(I \otimes p) = p(p \otimes I)$ implies $S_{N-1}S_N = 0$. The Hamiltonian $H_{XXZ,Hagen}^{(N)}$ is defined as

$$H_{XXZ,Hagen}^{(N)} \equiv S_{N+1} S_{N+1}^\dagger + S_N^\dagger S_N.$$

The right hand side can be expanded in terms of the local supercharge as

$$H_{XXZ,Hagen}^{(N)} = \sum_{i=1}^{N-1} g_{i,i+1}(p, p^\dagger) + \frac{1}{2}p_1p_1^\dagger + \frac{1}{2}p_Np_N^\dagger,$$

where $g : V \otimes V \rightarrow V \otimes V$ is given by

$$g(p, p^\dagger) = -(I \otimes p)(p^\dagger \otimes I) - (p \otimes I)(I \otimes p^\dagger) + p^\dagger p + \frac{1}{2}(pp^\dagger \otimes I + I \otimes pp^\dagger), \quad (2.5)$$

and $g_{i,i+1}$ is the function g acting on $\{i, i+1\}$ th sites. The terms of the interaction of the i th and $i+1$ th sites will be called the Hamiltonian density, and the terms acting on the left most site and the right most site will be called the left and the right boundary matrix. It is worth noting that the boundary matrices are the same on the left and the right. It is $\frac{1}{2}pp^\dagger$ at both V_1 and V_N . A direct calculation shows that

$$\begin{aligned} g(p, p^\dagger) &\equiv \begin{bmatrix} 1 & 0 & 0 & 0 \\ 0 & -1 & \frac{1}{2} & 0 \\ 0 & \frac{1}{2} & -1 & 0 \\ 0 & 0 & 0 & 1 \end{bmatrix}, \\ &= -\frac{1}{2}(\sigma^x \otimes \sigma^x + \sigma^y \otimes \sigma^y - \frac{1}{2}\sigma^z \otimes \sigma^z) + \frac{3}{4}\mathbb{I}, \end{aligned}$$

where I is the identity matrix. Hence $g(p, p^\dagger)$ is equal to the Hamiltonian density of $H_{XYZ}^{(N)}$ given in equation (2.1) at the point $J_x = 1$, $J_y = 1$ and $J_z = -\frac{1}{2}$, or equivalently the Hamiltonian density of the XXZ chain at $\eta = \frac{2i\pi}{3}$. Hence $H_{XXZ,Hagen}^{(N)}$ is the XXZ chain with lattice SUSY, and it can be written out using Pauli matrices as

$$H_{XXZ,Hagen}^{(N)} = -\frac{1}{2} \sum_{i=1}^{N-1} (\sigma_i^x \otimes \sigma_{i+1}^x + \sigma_i^y \otimes \sigma_{i+1}^y - \frac{1}{2}\sigma_i^z \otimes \sigma_{i+1}^z) + \frac{3}{4}(N-1)\mathbb{I} + \frac{1}{2}p_1p_1^\dagger + \frac{1}{2}p_Np_N^\dagger,$$

where I is the identity matrix and the local supercharge p is defined in the relation (2.2).

The left and the right-boundary matrices of $H_{XXZ,Hagen}^{(N)}$ are the same. This limitation is removed by considering a different construction for the conjugate of

the lattice supercharge $(S_{N+1}^{mn})^\dagger$ [67]

$$(S_{N+1}^{mn})^\dagger : V^{\otimes N} \rightarrow V^{N+1},$$

where $m, n = 1, 2, 3$. The action of $(S_{N+1}^{mn})^\dagger$ on a vector $|\phi\rangle \in V^{\otimes N}$ is

$$(S_{N+1}^{mn})^\dagger |\phi\rangle = |\xi_m\rangle \otimes |\phi\rangle + (-1)^{N-1} |\phi\rangle \otimes |\xi_n\rangle - (S_{N+1})^\dagger |\phi\rangle.$$

The vectors in the right hand side are

$$|\xi_0\rangle = \begin{bmatrix} (\omega^2 - 1)y \\ (\omega - 1)y^2 \end{bmatrix}, |\xi_1\rangle = \begin{bmatrix} (\omega - 1)y \\ (\omega^2 - 1)y^2 \end{bmatrix}, |\xi_2\rangle = 0,$$

with $\omega = -e^{-i\pi/3}$. They are the only three solutions which satisfy the condition

$$p^\dagger |\xi\rangle = |\xi\rangle \otimes |\xi\rangle.$$

Using the nilpotency of S_N , it is easy to check that S_N^{mn} is also nilpotent. $H_{XXZ,m,n}^{(N)}$ will be defined as

$$\begin{aligned} H_{XXZ,m,n}^{(N)} &\equiv S_{N+1}^{mn} (S_{N+1}^{mn})^\dagger + (S_N^{mn})^\dagger S_N^{mn}, \\ &= \sum_{i=1}^{N-1} g_{i,i+1}(p, p^\dagger) + \frac{1}{2} p_1^{(m)} p_1^{(m)\dagger} + \frac{1}{2} p_N^{(n)} p_N^{(n)\dagger}, \end{aligned}$$

where $p^{(n)}$ is $p(\omega^{n+1}y)$ and $p(y)$ is defined in the relation (2.3), i.e, it is p with variable y substitute by $\omega^{n+1}y$. Hence $H_{XXZ,Hagen}^{(N)'}$ is the XXZ chain Hamiltonian with lattice SUSY, and it can be written out using Pauli matrices as

$$H_{XXZ,Hagen}^{(N)'} = -\frac{1}{2} \sum_{i=1}^{N-1} (\sigma^x \otimes \sigma^x + \sigma^y \otimes \sigma^y - \frac{1}{2} \sigma^z \otimes \sigma^z) + \frac{3}{4} (N-1) \mathbb{I} + \frac{1}{2} p_1^{(m)} p_1^{(m)\dagger} + \frac{1}{2} p_N^{(n)} p_N^{(n)\dagger},$$

where I is the identity matrix.

2.3 The General Solutions for The Local Supercharge

In the previous section, the integrable Hamiltonians $H_{XXZ,Hagen}^{(N)}$ and $H_{XXZ,Hagen}^{(N)'}$ with lattice SUSY on the open spin chain has been studied. This section will extend the construction of $H_{XXZ,Hagen}^{(N)}$.

The following local supercharge will be used to construct the new integrable supersymmetric Hamiltonian.

Definition 1. *The local supercharge p is*

$$p : V \otimes V \rightarrow V.$$

The components of this map are given by

$$p = \begin{bmatrix} 2(r_{32} + ic_{32}) & r_{31} + ic_{31} & r_{31} + ic_{31} & r_{41} + ic_{41} \\ r_{12} + ic_{12} & r_{32} + ic_{32} & r_{32} + ic_{32} & 2(r_{31} + ic_{31}) \end{bmatrix}.$$

where $\{r_{32}, r_{31}, r_{12}, r_{41}, c_{32}, c_{31}, c_{12}, c_{41}\}$ are real numbers. They satisfy relations

$$\left\{ \begin{array}{l} r_{12}^2 + r_{41}^2 + c_{12}^2 + c_{41}^2 = 1 \\ r_{31}c_{12} + c_{31}r_{12} + 2r_{32}c_{32} = 0 \\ r_{32}c_{41} + c_{32}r_{41} + 2r_{31}c_{31} = 0 \\ c_{31}c_{12} + c_{32}^2 - r_{31}r_{12} - r_{32}^2 = 0 \\ c_{32}c_{41} + c_{31}^2 - r_{32}r_{41} - r_{31}^2 = 0 \\ c_{12}r_{41} + r_{12}c_{41} - r_{32}c_{31} - c_{32}r_{31} = 0 \\ c_{12}c_{41} - r_{12}r_{41} + r_{32}r_{31} - c_{32}c_{31} = 0 \end{array} \right. .$$

The motivation of eight relations in the end of Definition 1 will be clear after the introduction of Proposition 2. The lattice supercharge S_N is defined in relation (2.4).

The Hamiltonian $H_{XXZ,SUSY}^{(N)}$ is the anti-commutator of the lattice supercharges, i.e.,

$$H_{XXZ,SUSY}^{(N)} \equiv S_{N+1}S_{N+1}^\dagger + S_N^\dagger S_N.$$

This Hamiltonian can be expanded in terms of the local supercharge

$$H_{XXZ,SUSY}^{(N)} = \sum_{i=1}^{N-1} g_{i,i+1}(p, p^\dagger) + \frac{1}{2}p_1p_1^\dagger + \frac{1}{2}p_Np_N^\dagger,$$

where g is defined relation (2.5). By direct calculation, it is easy to see that

$$\begin{aligned} g(p, p^\dagger) &:= \begin{bmatrix} 1 & 0 & 0 & 0 \\ 0 & -1 & \frac{1}{2} & 0 \\ 0 & \frac{1}{2} & -1 & 0 \\ 0 & 0 & 0 & 1 \end{bmatrix}, \\ &= -\frac{1}{2}(\sigma^x \otimes \sigma^x + \sigma^y \otimes \sigma^y - \frac{1}{2}\sigma^z \otimes \sigma^z) + \frac{3}{4}\mathbb{I}, \end{aligned}$$

and

$$p(I \otimes p) = p(p \otimes I).$$

The above relation implies S_N in (2.4) is nilpotent. Hence $H_{XXZ,SUSY}^{(N)}$ is the XXZ spin chain Hamiltonian with lattice SUSY.

$$H_{XXZ,SUSY}^{(N)} = -\frac{1}{2} \sum_{i=1}^{N-1} (\sigma_i^x \otimes \sigma_{i+1}^x + \sigma_i^y \otimes \sigma_{i+1}^y - \frac{1}{2}\sigma_i^z \otimes \sigma_{i+1}^z) + \frac{3}{4}(N-1)\mathbb{I} + \frac{1}{2}p_1p_1^\dagger + \frac{1}{2}p_Np_N^\dagger, \quad (2.6)$$

where I is the identity matrix and the local supercharge p is defined in Definition 1.

It is worth noting that p has the following properties

Proposition 2. *The local supercharge in definition 1 is the most general solution which satisfies the following requirements*

- *The Hamiltonian density $g(p, p^\dagger)$ in the relation (2.5) is equal to the Hamilto-*

nian density of the spin-half XXZ chain Hamiltonian at $\eta = \frac{2i\pi}{3}$

$$g(p, p^\dagger) = \begin{bmatrix} 1 & 0 & 0 & 0 \\ 0 & \frac{1}{2} & -1 & 0 \\ 0 & -1 & \frac{1}{2} & 0 \\ 0 & 0 & 0 & 1 \end{bmatrix}.$$

- The local supercharge satisfies the condition $p(I \otimes p) = p(p \otimes I)$.

Proposition 2 will be proved with some help from Maple software to solve polynomial equations. The following lemma is needed

Lemma 3. *All solutions of local supercharge satisfying the two requirements in Proposition 2 have the following form*

$$p = \begin{bmatrix} 2(r_{32} + ic_{32}) & r_{31} + ic_{31} & r_{31} + ic_{31} & r_{41} + ic_{41} \\ r_{12} + ic_{12} & r_{32} + ic_{32} & r_{32} + ic_{32} & 2(r_{31} + ic_{31}) \end{bmatrix}. \quad (2.7)$$

Proof. The most general form of the complex local supercharge is

$$p = \begin{bmatrix} r_{11} + ic_{11} & r_{21} + ic_{21} & r_{31} + ic_{31} & r_{41} + ic_{41} \\ r_{12} + ic_{12} & r_{22} + ic_{22} & r_{32} + ic_{32} & r_{42} + ic_{42} \end{bmatrix},$$

where all variables are real. By only imposing the second requirement in Proposition

2, a solution of p is obtained with

$$\left\{ \begin{array}{l}
 c_{11} = (c_{31}^2 c_{41} - c_{31} c_{41} c_{42} + 2c_{31} r_{31} r_{41} - c_{31} r_{41} r_{42} \\
 + c_{32} c_{41}^2 + c_{32} r_{41}^2 - c_{41} r_{31}^2 + c_{41} r_{31} r_{42} - c_{42} r_{31} r_{41}) / (c_{41}^2 + r_{41}^2) \\
 c_{12} = (c_{31} c_{32} c_{41} + c_{31} r_{32} r_{41} + c_{32} r_{31} r_{41} - c_{41} r_{31} r_{32}) / (c_{41}^2 + r_{41}^2) \\
 c_{21} = c_{31} \\
 c_{22} = c_{32} \\
 r_{11} = (-c_{31}^2 r_{41} - 2c_{31} c_{41} r_{31} + c_{31} c_{41} r_{42} - c_{31} c_{42} r_{41} \\
 - c_{41}^2 r_{32} + c_{41} c_{42} r_{31} - r_{31}^2 r_{41} + r_{31} r_{41} r_{42} - r_{32} r_{41}^2) / (c_{41}^2 + r_{41}^2) \\
 r_{12} = (-c_{31} c_{32} r_{41} - c_{31} c_{41} r_{32} - c_{32} c_{41} r_{31} - r_{31} r_{32} r_{41}) / (c_{41}^2 + r_{41}^2) \\
 r_{21} = r_{31} \\
 r_{22} = r_{32}
 \end{array} \right. . \quad (2.8)$$

For the local supercharge p defined in the beginning of the proof, the relation (2.8) is a necessary condition of requirements in Proposition 2. Using relation (2.8), another necessary condition can be obtained. By omitting the expression for c_{12} in the relation (2.8), and substituting the rest of the relation (2.8) into the first requirement in Proposition 2, a matrix relation will be obtained. The entries of this matrix equation gives a system of equations with variables $\{r_{32}, r_{31}, r_{12}, r_{41}, c_{32}, c_{31}, c_{12}, c_{41}\}$. Using Maple software, this system of equations can be solved for real solution. The solution is a necessary condition where the local supercharge p satisfies the requirements in Proposition 2. In this solution, there are relations $c_{11} = 2c_{32}$ and $r_{11} = 2r_{32}$.

Similarly, if the expression for r_{12} in the relation (2.8) is omitted, and the rest of the relation (2.8) is substituted into the first requirement in Proposition 2, another matrix equation will be obtained. The real solution of this equation is another necessary condition where local supercharge p satisfies the requirements in Proposition 2. In this solution, there are the relations $c_{42} = 2c_{31}$ and $r_{42} = 2r_{31}$. Combining $c_{11} = 2c_{32}$, $r_{11} = 2r_{32}$, $c_{42} = 2c_{31}$, $r_{42} = 2r_{31}$ and the third, fourth, seventh and

eighth relation in (2.8), it will give the following relations

$$\left\{ \begin{array}{l} c_{11} = 2c_{32} \\ r_{11} = 2r_{32} \\ c_{21} = c_{31} \\ r_{21} = r_{31} \\ c_{42} = 2c_{31} \\ r_{42} = 2r_{31} \\ c_{22} = c_{32} \\ r_{22} = r_{32} \end{array} \right. . \quad (2.9)$$

This is a necessary condition of requirements in Proposition 2. Under condition (2.9), the simplified local supercharge is

$$p = \begin{bmatrix} 2(r_{32} + ic_{32}) & r_{31} + ic_{31} & r_{31} + ic_{31} & r_{41} + ic_{41} \\ r_{12} + ic_{12} & r_{32} + ic_{32} & r_{32} + ic_{32} & 2(r_{31} + ic_{31}) \end{bmatrix}.$$

□

The proof of Proposition 2 is then as follows:

Proof. The Hamiltonian density $g(p, p^\dagger)$ given by relation (2.5) constructed from the simplified p in the relation (2.7) becomes

$$\begin{bmatrix} r_{12}^2 + r_{41}^2 + c_{12}^2 + c_{41}^2 & 0 & 0 & 0 \\ 0 & \frac{r_{12}^2 + r_{41}^2 + c_{12}^2 + c_{41}^2}{2} & -(r_{12}^2 + r_{41}^2 + c_{12}^2 + c_{41}^2) & 0 \\ 0 & -(r_{12}^2 + r_{41}^2 + c_{12}^2 + c_{41}^2) & \frac{r_{12}^2 + r_{41}^2 + c_{12}^2 + c_{41}^2}{2} & 0 \\ 0 & 0 & 0 & r_{12}^2 + r_{41}^2 + c_{12}^2 + c_{41}^2 \end{bmatrix}$$

Hence the first requirement in Proposition 2 implies

$$r_{12}^2 + r_{41}^2 + c_{12}^2 + c_{41}^2 = 1.$$

The nilpotency condition $p(I \otimes p) = p(p \otimes I)$ for p in the relation (2.7) can be solved, and it gives equations

$$\left\{ \begin{array}{l} r_{31}c_{12} + c_{31}r_{12} + 2r_{32}c_{32} = 0 \\ r_{32}c_{41} + c_{32}r_{41} + 2r_{31}c_{31} = 0 \\ c_{31}c_{12} + c_{32}^2 - r_{31}r_{12} - r_{32}^2 = 0 \\ c_{32}c_{41} + c_{31}^2 - r_{32}r_{41} - r_{31}^2 = 0 \\ c_{12}r_{41} + r_{12}c_{41} - r_{32}c_{31} - c_{32}r_{31} = 0 \\ c_{12}c_{41} - r_{12}r_{41} + r_{32}r_{31} - c_{32}c_{31} = 0 \end{array} \right. .$$

All the above seven equations combined will be the conditions in Definition 1. \square

The local supercharge in Definition 1 will induce the integrable supersymmetric Hamiltonian $H_{XXZ,SUSY}^{(N)}$. By the discussion in Section 2.2, the local supercharge in the relation (2.3) will induce $H_{XXZ,Hagen}^{(N)}$, which is also a XXZ chain with lattice SUSY. It is natural to ask the relation of these two local supercharges.

In fact, the relation (2.3) is included in Definition 1. Hence $H_{XXZ,Hagen}^{(N)}$ is a special case of the more general $H_{XXZ,SUSY}^{(N)}$. A parametrisation of a subset of solutions in Definition 1 has been found, which gives the relation (2.3). In order to use the parametrisation, the variable y in the relation (2.3) is written as $y = a + ib$, where a and b are real numbers. The local supercharge in Definition 1 can be

rewritten as the following

$$\left\{ \begin{array}{l} r_{32} = -ax \\ c_{32} = -bx \\ r_{31} = (-a^2 + b^2)x \\ c_{31} = (-2ab)x \\ r_{12} = x \\ c_{12} = 0 \\ r_{41} = (a^3 - 3ab^2)x \\ c_{41} = (3a^2b - b^3)x \end{array} \right. . \quad (2.10)$$

The following check confirms that p in relation (2.7) with parametrisation (2.10) satisfies conditions in Definition 1

$$r_{12}^2 + r_{41}^2 + c_{12}^2 + c_{41}^2 = x^2(1 + (a^3 - 3ab^2)^2 + (3a^2b - b^3)^2) = \frac{1 + |y^3|^2}{1 + |y|^6} = 1.$$

This implies the first relation in Definition 1 is satisfied.

$$r_{31}c_{12} + c_{31}r_{12} + 2r_{32}c_{32} = x^2(-2ab + 2(-a)(-b)) = 0.$$

This implies the second relation in Definition 1 is satisfied.

$$r_{32}c_{41} + c_{32}r_{41} + 2r_{31}c_{31} = x^2((-a)(3a^2b - b^3) + (-b)(a^3 - 3ab^2) + 2(b^2 - a^2)(-2ab))$$

$$= x^2(-3a^3b + ab^3 - a^3b + 3ab^3 - 4ab^3 + 4a^3b) = 0,$$

$$c_{31}c_{12} + c_{32}^2 - r_{31}r_{12} - r_{32}^2 = x^2((-b)^2 - (b^2 - a^2) - (-a)^2)$$

$$= x^2(b^2 - b^2 + a^2 - a^2) = 0,$$

$$c_{32}c_{41} + c_{31}^2 - r_{32}r_{41} - r_{31}^2 = x^2((-b)(3a^2b - b^3) + (-2ab)^2 - (-a)(a^3 - 3ab^2) - (b^2 - a^2)^2)$$

$$= x^2(-3a^2b^2 + b^4 + 4a^2b^2 + a^4 - 3a^2b^2 - b^4 - a^4 + 2a^2b^2) = 0,$$

$$\begin{aligned}
 c_{12}r_{41} + r_{12}c_{41} - r_{32}c_{31} - c_{32}r_{31} &= x^2(3a^2b - b^3 - (-a)(-2ab) - (-b)(b^2 - a^2)) \\
 &= x^2(3a^2b - b^3 - 2a^2b + b^3 - a^2b) = 0,
 \end{aligned}$$

$$\begin{aligned}
 c_{12}c_{41} - r_{12}r_{41} + r_{32}r_{31} - c_{32}c_{31} &= x^2(-a^3 + 3ab^2 + (-a)(b^2 - a^2) - (-b)(-2ab)) \\
 &= x^2(-a^3 + 3ab^2 - ab^2 + a^3 - 2ab^2) = 0.
 \end{aligned}$$

Similarly, the above relations show that the third to the seventh relations in Definition 1 are satisfied. The local supercharge is parametrised by a and b , and it has the same form as in the relation (2.3)

$$\begin{aligned}
 p &= x \begin{bmatrix} -2a - i2b & -a^2 + b^2 - i2ab & -a^2 + b^2 - i2ab & a^3 - 3ab^2 + i(3a^2b - b^3) \\ 1 & -a - ib & -a - ib & -2a^2 + 2b^2 - i4ab \end{bmatrix}, \\
 &= x \begin{bmatrix} -2(a + ib) & -(a + ib)^2 & -(a + ib)^2 & (a + ib)^3 \\ 1 & -(a + ib) & -(a + ib) & -2(a + ib)^2 \end{bmatrix}, \\
 &= x \begin{bmatrix} -2y & -y^2 & -y^2 & y^3 \\ 1 & -y & -y & -2y^2 \end{bmatrix}.
 \end{aligned}$$

Hence the relation (2.3) is a subset of the solutions in Definition 1.

In summary, in Section 2.1, a Hamiltonian was constructed from $S_N = \sum_{i=1}^N (-1)^{i+1} p_i$ which has the same boundary matrices on the left and the right. In Section 2.2, a generalised lattice supercharge S_N^{nm} was defined, such that the induced Hamiltonian has different boundary matrices. However, this generalisation is built on the local supercharge in the relation (2.3). It remains a problem to define a generalised lattice supercharge S_N^{nm} using p as defined in Definition 1.

Chapter 3

The Bethe Ansatz for Vertex

Models

This chapter will be introduce existing results of the algebraic Bethe ansatz for both closed and the open boundary conditions, and TQ equations for open boundary conditions. In Section 3.1, the vertex model will be introduced, and the Lax operator and the transfer matrix with the periodic boundary conditions will be defined for this model. In Section 3.2, a Lax operator which satisfies the Yang-Baxter equation will be defined. The transfer matrices induced from this Lax operator will form a commuting family. Section 3.3 will give an introduction to the algebraic Bethe ansatz methods for the transfer matrix with periodic boundary conditions. In Section 3.4, the K -matrices will be introduced. Using it, the construction of the transfer matrix can be extended to the open boundary condition. The K -matrices and the R -matrix satisfy the reflection equations. From the reflection equations, it can be proved that the transfer matrices form a commuting family as in the periodic case. The algebraic Bethe ansatz will also be introduced for the transfer matrix constructed from diagonal K -matrices. In Section 3.5, another method to solve the spectrum of the transfer matrix will be introduced, which is called the TQ equations. Using TQ equations, the eigenvalues of the transfer matrix constructed from the non-diagonal K -matrices can be solved.

3.1 Vertex Model

This section will introduce the two-dimensional lattice model and its partition function. The transfer matrix will be defined for this lattice model, and the partition function will be expressed by eigenvalues of the transfer matrix. Consider a lattice of M horizontal lines and N vertical lines, the point where two lines intersect will be called a vertex, and the line segment between two nearby vertices will be called an edge. An arrow will be put on every edge of this lattice. There are even numbers of arrows going out of and into a vertex, and the lattice has toroidal boundary condition, i.e. an arrow on the upper most edge has the same direction with the arrow on the lower-most edge on the same vertical line, and the arrows on the left and right are identified by the same rule. For every vertex, there are four arrows nearby pointing from and to it; together the eight possibilities have been shown in the figure below, which is an example of a 4×4 lattice model.

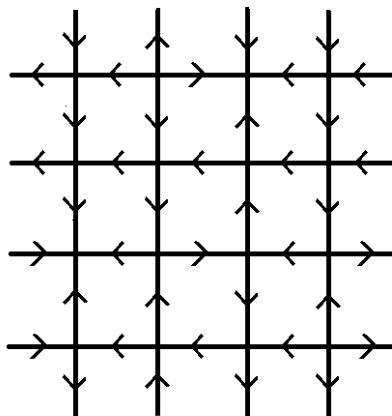

For each kind of vertices, there is a weight associated to it. This weight will be called the Boltzmann weight, and will be denote as ω_k where $k \in \{1, 2, 3, 4, 5, 6, 7, 8\}$. The Boltzmann weight is a scalar function of complex parameters, which depends on the individual vertex. The following diagram gives all possible configurations of a single vertex

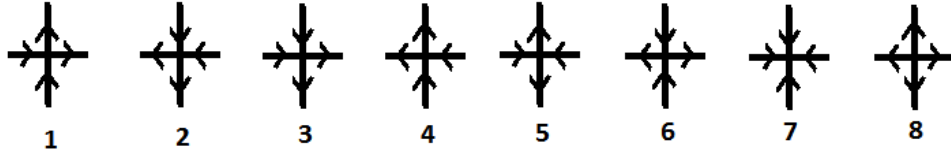

When the lattice model does not include the last two configurations of vertices, it will be called the six vertex model. The lattice model with all eight configurations is called the eight vertex model.

The Hilbert space V defined in Section 2.1 will be associated to the edges of the lattice model, and the tensor product space $V^{\otimes N}$ will be associated to N parallel edges. The basis of V is defined as the same way as in Chapter 2. Let $\epsilon_i, \epsilon'_i, \epsilon_j, \epsilon'_j$ denote the values of the left horizontal, right horizontal, upper vertical and lower vertical edges around the vertex at i th row and j th column respectively. The diagram of this vertex is

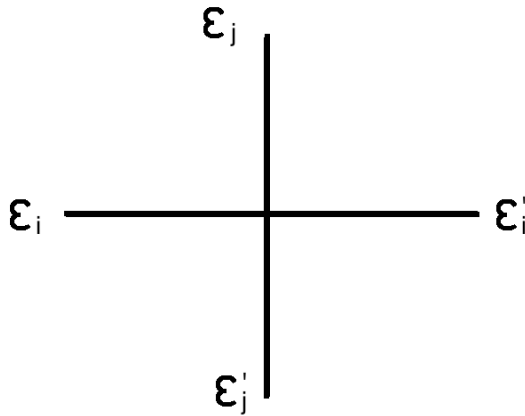

The Boltzmann weight of this vertex will be denoted as $\omega_{\epsilon'_i \epsilon'_j}^{\epsilon_i \epsilon_j} \in \{\omega_1, \dots, \omega_8\}$. The thermodynamic properties of the vertex model can be calculated using the partition function Z

$$Z = \sum \prod \omega_{\epsilon'_i \epsilon'_j}^{\epsilon_i \epsilon_j},$$

where the summation is taken over all possible lattice configurations and the multiplication is taken over all rows and columns of the lattice model. To write the partition function in a more compact way, it will be helpful to consider a single row in the lattice model. The N parallel vertical edges above and below the horizontal

line are both associated with $V^{\otimes N}$. Thus this row can be considered as a map from $V^{\otimes N}$ to itself. The component of the map from element $a \in V^{\otimes N}$ to $b \in V^{\otimes N}$ will be defined as the product of Boltzmann weights of the configuration of a single row. This map will be called the transfer matrix, and will be denoted as $t(u)$. Let $\omega_1(u), \dots, \omega_N(u)$ be the Boltzmann weights of the 1st to the N th vertex from the left to the right. The transfer matrix will be defined as

$$t(u) : V^{\otimes N} \rightarrow V^{\otimes N},$$

$$a \rightarrow (\prod_{i=1}^N \omega_i(u))b,$$

where u is the parameter of the Boltzmann weight on this row, and it will be called the spectral parameter of the transfer matrix. Later on in this chapter, the parameter of the Boltzmann weight of a single vertex will be defined as the difference of parameters associated with the two lines going through this vertex. Let the parameters of the transfer matrices of $1, \dots, M$ rows be u_1, \dots, u_M , the partition function can be expressed as

$$Z = \text{tr}(\prod_{i=1}^M t(u_i)).$$

When the transfer matrices are hermitian and transfer matrices with different values of u commute with each other, they can be diagonalised simultaneously. The transfer matrix with this property will be called integrable. Let the eigenvalues of $t(u_i)$ be $\{e_1(u_i), \dots, e_{2N}(u_i)\}$, the partition function can be expressed as

$$Z = \prod_{i=1}^M e_1(u_i) + \dots + \prod_{i=1}^M e_{2N}(u_i).$$

From this partition function, other thermodynamic properties of this model can be derived. From now on, the attention will be restricted to the integrable transfer matrix.

3.2 Yang-Baxter Equation and Integrability

This section will give the construction of a one parameter family of transfer matrices, such that any two transfer matrices within this family will commute with each other, i.e. $[t(u), t(v)] = 0$ for any parameters u and v .

The diagram of the transfer matrix is a single row of a vertex model with toroidal boundary conditions, it can be constructed from single crosses in the lattice. The cross at i th row and j th column will be identified with an operator called the Lax operator $L_{i,j}(u_i - u_j)$

$$L_{i,j}(u_i - u_j) : V_i \otimes V_j \rightarrow V_i \otimes V_j.$$

As the space V which is identified with a single edge in the lattice model, the diagrammatical representations for the Lax operator can also be defined. The details can be found in [73]. The diagram of $L_{i,j}(u_i - u_j)$ is

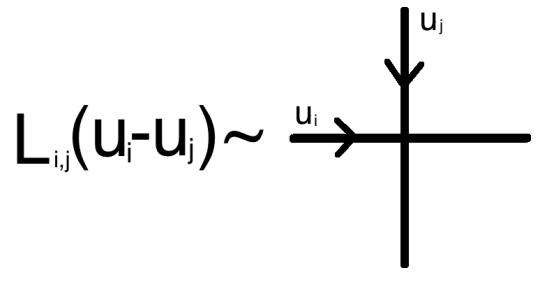

where the arrow indicates this is a map from the tensor product space $V \otimes V$ on the west and north to the tensor product space $V \otimes V$ on the south and the east. The space V_i is associated to the spaces at the east and the west and V_j is associated to the spaces at the north and the south. The components of $L_{i,j}(u_i - u_j)$ from $\epsilon_i \otimes \epsilon_j \in V \otimes V$ to $\epsilon'_i \otimes \epsilon'_j \in V \otimes V$ is the Boltzmann weight $\omega_{\epsilon'_i \epsilon'_j}^{\epsilon_i \epsilon_j}$. The value of the component of the map can also be represented by the diagram. For example, the component of $L_{i,j}(u_i - u_j)$ from $(+) \otimes (+)$ to $(+) \otimes (+)$ is

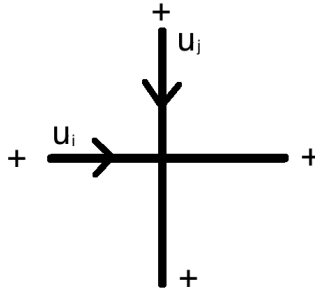

A new operator can be constructed by the product of N Lax operators. This operator will be called the monodromy matrix $M_N(u)$, and it is defined as

$$M_N(u) \equiv L_{0,N}(u) \dots L_{0,2}(u)L_{0,1}(u).$$

The diagram of $M_N(u)$ is constructed by connecting N diagrams of Lax operators from the left to the right

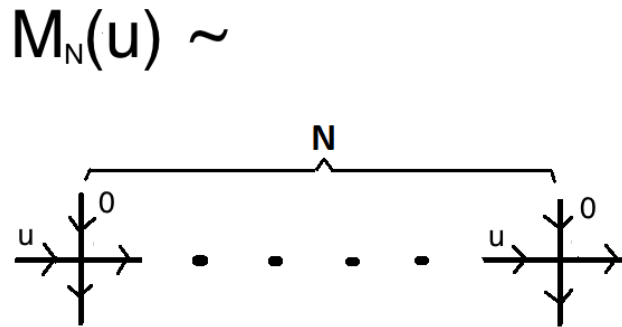

The N parallel vertical lines which start and end on $V_1 \otimes \dots \otimes V_N$, and $V_1 \otimes \dots \otimes V_N$ will be called a the quantum space. The horizontal line that runs through them starts and ends on the space V_0 . V_0 will be called a the auxiliary space. All parameters on the quantum spaces will be set to zeros, and the parameter on auxiliary space is u . The monodromy matrix $M_N(u)$ is a operator from $V_0 \otimes V_1 \otimes \dots \otimes V_N$ to itself.

The transfer matrix is obtained by taking the trace of the auxiliary space of $M_N(u)$, i.e,

$$t(u) = tr_0 M_N(u).$$

which means restricting the input and output of $M_N(u)$ on the auxiliary space to be the same.

The diagram of $t(u)$ is obtained from the diagram of $M_N(u)$ by restricting the values of the left-most and the right-most horizontal edges to be the same

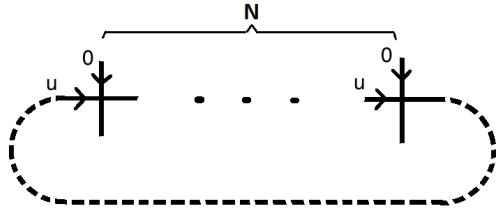

where the parameter of the auxiliary space is u , and the parameters of quantum spaces are zeros. The dotted line connecting the auxiliary space on the left side and the right side is the notation for taking a trace.

The R -matrix is essential in the construction of the integrable transfer matrix. It is defined as

$$R(u) = \begin{bmatrix} \sinh(u + \eta) & 0 & 0 & 0 \\ 0 & \sinh(u) & \sinh(\eta) & 0 \\ 0 & \sinh(\eta) & \sinh(u) & 0 \\ 0 & 0 & 0 & \sinh(u + \eta) \end{bmatrix}. \quad (3.1)$$

It has certain important properties [74], and there are three which are needed in this thesis.

The first property is called the Yang-Baxter equation, i.e.

$$R_{1,2}(u_1 - u_2)R_{1,3}(u_1 - u_3)R_{2,3}(u_2 - u_3) = R_{2,3}(u_2 - u_3)R_{1,3}(u_1 - u_3)R_{1,2}(u_1 - u_2), \quad (3.2)$$

where $R_{ij}(u)$ with $i, j = 1, 2, 3$ act on the i th and the j th copies of space $V_1 \otimes V_2 \otimes V_3$.

The Yang-Baxter equation can be represented using the diagram

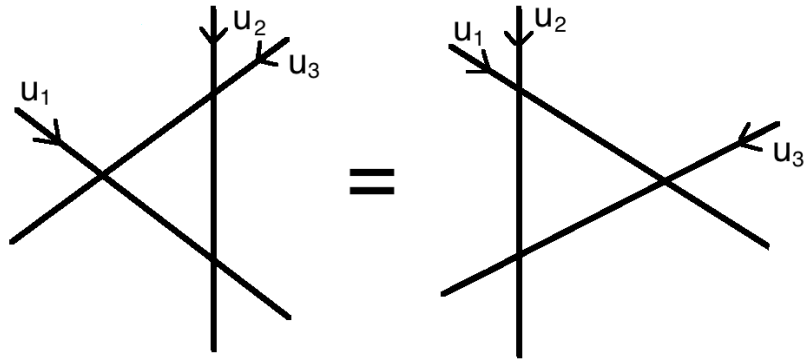

Intuitively, the diagram on the right side is obtained by moving the line with the parameter u_3 to the other side of the intersection of other two lines. By identifying $V_1 \otimes V_2 \otimes V_3$ with $V_0 \otimes V_{0'} \otimes V_n$, and defines the Lax operator to be the R -matrix, i.e. $L(u) \equiv R(u)$, the Yang-Baxter equation becomes

$$R_{0,0'}(u-v)L_{0,n}(u)L_{0',n}(v) = L_{0',n}(v)L_{0,n}(u)R_{0,0'}(u-v). \quad (3.3)$$

Using this relation repeatedly, a commutation relation between monodromy matrices can be obtained

$$R_{0,0'}(u-v)M_0(u)M_{0'}(v) = M_{0'}(v)M_0(u)R_{0,0'}(u-v). \quad (3.4)$$

The above relation can be proved using diagrams. The diagram for the right hand side of the above equation is

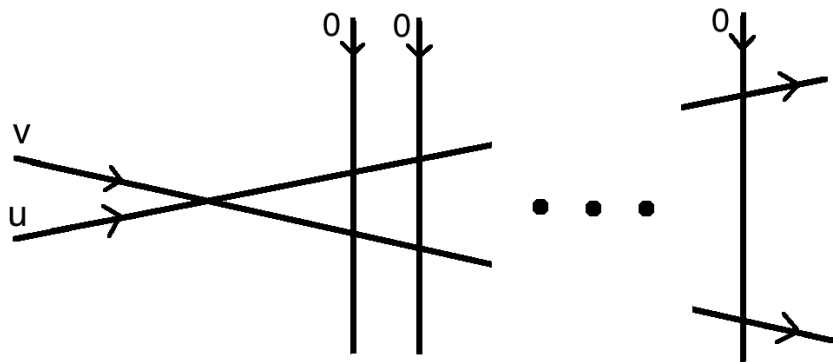

where the line with parameter u represents the auxiliary space V_0 , the line with parameter v represents the auxiliary space $V_{0'}$ and all the vertical lines with parameters 0 represent quantum spaces from V_1 to V_N . Using the Yang-Baxter equation,

the left-most vertical line can be moved to the other side of the intersection of lines representing the two auxiliary spaces. The result is

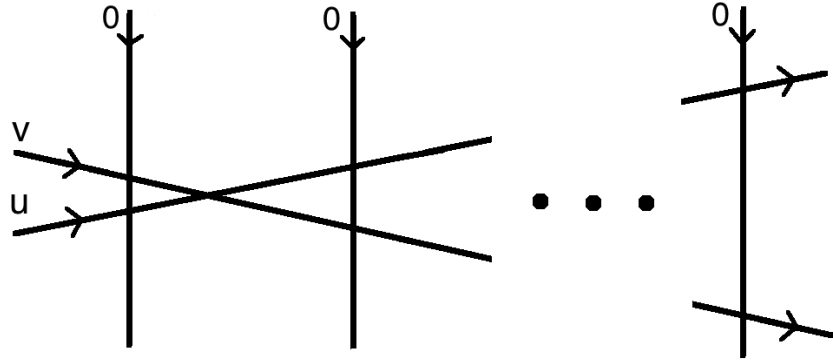

Using Yang-Baxter equation repeatedly, the above diagram becomes

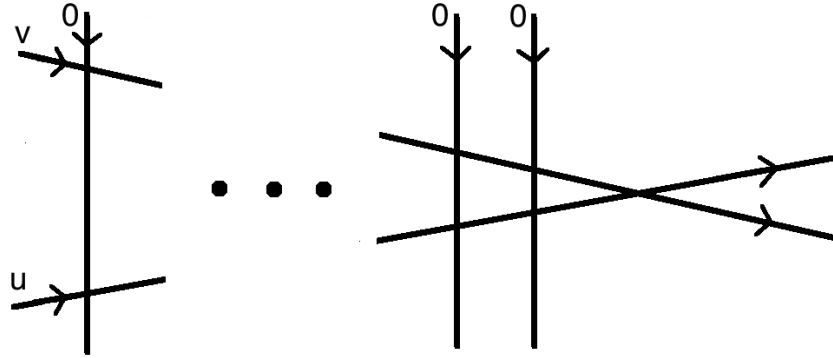

This is exactly the left hand side of the relation (3.4), and hence (3.4) is true. It is worth noting that the relation (3.4) is also useful in calculating the algebraic Bethe ansatz, which will be explained in the next section.

The second property is the unitarity property, i.e.

$$R_{1,2}(u-v)R_{2,1}(v-u) = -z(u-v)\mathbb{I}, \quad (3.5)$$

where $z(u) = \sinh(u+\eta)\sinh(u-\eta)$. The unitarity can be represented by the diagram

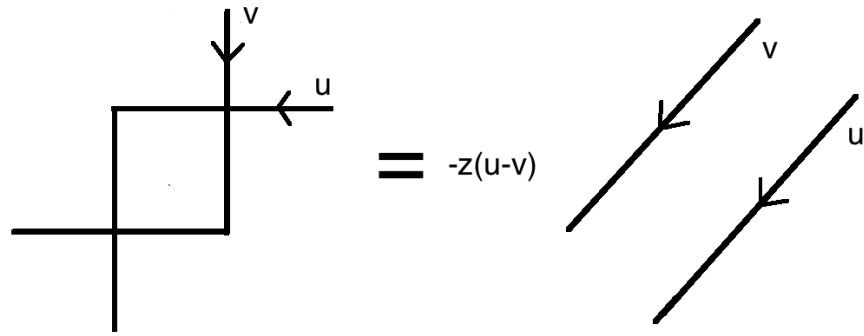

Using the Yang-Baxter equation and the unitarity condition, the following relation can be proved

$$[t(u), t(v)] = 0,$$

where u and v are any complex number. This implies that the transfer matrix is integrable. The integrability can be proved by diagrams. The diagram for $t(u)t(v)$ is

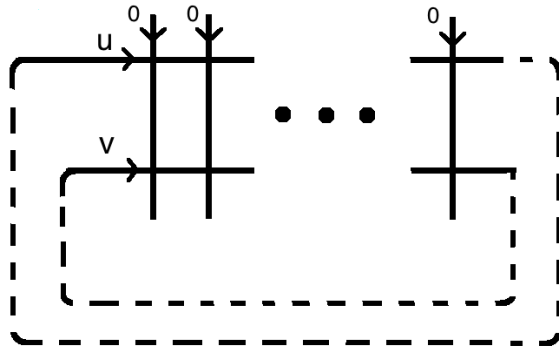

Using the unitarity, the diagram for $t(u)t(v)$ becomes

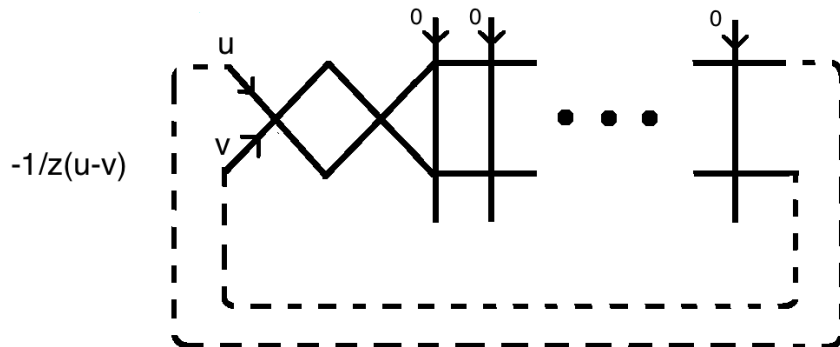

Using the relation (3.4), the above diagram becomes

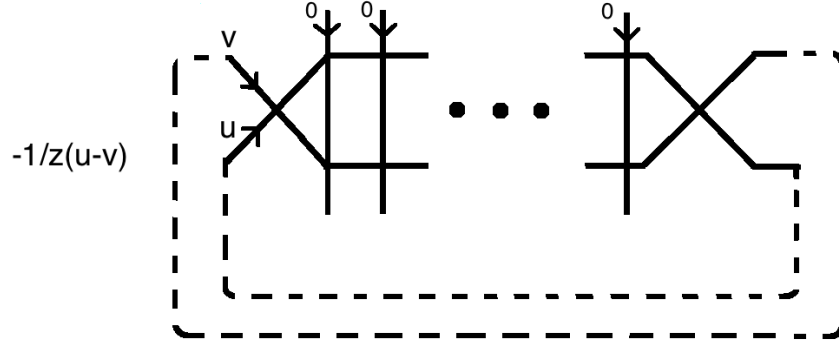

The above diagram represents $\frac{1}{-z(u-v)} \text{tr}_{0,0'}(R_{0',0}(v-u)M_0(v)M_{0'}(u)R_{0,0'}(u-v))$.

Using the property of the trace and the unitarity, it follows that

$$\begin{aligned} & \frac{1}{-z(u-v)} \text{tr}_{0,0'}(R_{0',0}(v-u)M_0(v)M_{0'}(u)R_{0,0'}(u-v)) \\ &= \frac{1}{-z(u-v)} \text{tr}_{0,0'}(M_0(v)M_{0'}(u)R_{0,0'}(u-v)R_{0',0}(v-u)), \\ &= \text{tr}_{0,0'}(M_0(v)M_{0'}(u)) = t(v)t(u). \end{aligned}$$

Hence $t(u)t(v) = t(v)t(u)$ for any complex numbers u and v , and $t(u)$ is integrable.

The third property is the crossing symmetry

$$R_{1,2}(u) = -\sigma_1^y R_{1,2}^{t_2}(-u-\eta)\sigma_1^y, \quad (3.6)$$

where t_2 means the transposition on the space V_2 . This property will be used in the next section to obtain the integrability of the transfer matrix with open boundary conditions.

There is another way of understanding the relation (3.3) by using quantum groups [75] [76]. In the frame work of representation theory of the quantum group $U_q(\widehat{sl}_2)$, $R_{0,0'}(u)$ is the evaluation representation of the universal R -matrix \mathcal{R} on $V_0 \otimes V_{0'}$ and $L_{0,n}(u) = R_{0,n}(u)$ is the evaluation representation on $V_0 \otimes V_n$. The Yang-Baxter equation is the representation $\pi_{V_0 \otimes V_{0'} \otimes V_n}$ of the following relation, which is

a property of the universal R -matrix

$$\mathcal{R}_{12}\mathcal{R}_{13}\mathcal{R}_{23} = \mathcal{R}_{23}\mathcal{R}_{13}\mathcal{R}_{12}. \quad (3.7)$$

The monodromy matrix can also be constructed using the representation theory. Using the property involving the co-product Δ of $U_q(\widehat{sl_2})$

$$(1 \otimes \Delta)(\mathcal{R}) = \mathcal{R}_{13}\mathcal{R}_{12}.$$

It is easy to see that

$$(1 \otimes \Delta^{(N-1)})(\mathcal{R}) = \mathcal{R}_{1(N+1)} \dots \mathcal{R}_{13}\mathcal{R}_{12},$$

where $\Delta^{(n)} := (\Delta \otimes 1) \circ \Delta^{(n-1)}$ for $n > 1, n \in \mathbb{Z}$, and $\Delta^{(1)} := \Delta$. Hence the monodromy matrix is

$$M(u) \equiv (\pi_0 \otimes \pi_{V_1 \otimes \dots \otimes V_N})(\mathcal{R}),$$

where the representation of tensor product space $\pi_{V_1 \otimes \dots \otimes V_N}$ is defined as $(\pi_{V_1} \otimes \dots \otimes \pi_{V_N}) \circ \Delta^{(N-1)}$ for $N > 1$. Then it is easy to see that the representation $\pi_0 \otimes \pi_{0'} \otimes \pi_{V_1 \otimes \dots \otimes V_N}$ of the relation (3.7) gives the relation between monodromy matrices (3.4).

3.3 The Algebraic Bethe Ansatz for Periodic Boundary Condition

This section will introduce the Algebraic Bethe Ansatz [15] [77]. The monodromy matrix will be rewritten by expanding on auxiliary space V_0 :

$$M(u) = \begin{bmatrix} A_N(u) & B_N(u) \\ C_N(u) & D_N(u) \end{bmatrix},$$

where A_N, B_N, C_N, D_N are maps from quantum space $V^{\otimes N}$ to itself. Hence the transfer matrix can be written as

$$t(u) = A_N(u) + D_N(u).$$

By fixing the input and the output on the auxiliary space V_0 to be (+) and (+), the diagram of $A_N(u)$ is obtained

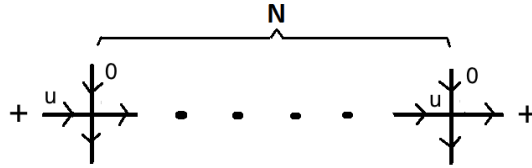

The diagram of $B_N(u)$ is

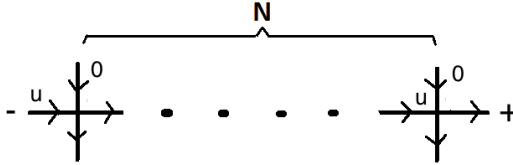

The diagram of $C_N(u)$ is

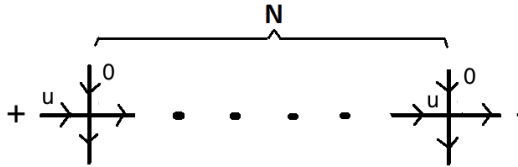

The diagram of $D_N(u)$ is

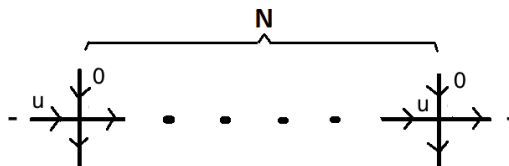

It is worth noting that by the choice of the Lax operator, there exists an element $\Omega \equiv \otimes_{i=1}^N v_+$ in the quantum space, such that

$$C_N(u)\Omega = 0.$$

This state Ω will be called the reference state. The above relation can be proved using diagrams. The diagram for $C(u)\Omega$ is

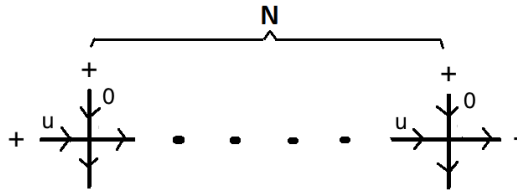

The value of edges of the diagram of $C_N(u)\Omega$ can be completed as

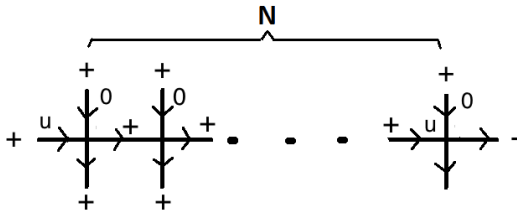

By the definition of the R -matrix in the relation (3.1), it is easy to see that the value of the Boltzmann weight of the right-most cross in the above diagram is zero, no matter what value the bottom-right vertical edge has. Hence $C(u)\Omega = 0$. Similarly, the value of edges of the diagram of $A_N(u)\Omega$ can be completed as

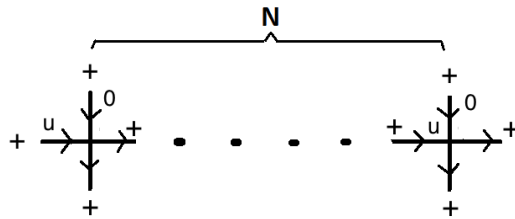

Hence, it follows that

$$A_N(u)\Omega = \sinh(u + \eta)^N \Omega.$$

The value of edges of the diagram of $D_N(u)\Omega$ can be completed as

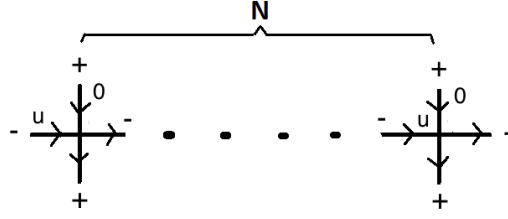

Hence, it follows that

$$D_N(u)\Omega = \sinh(u)^N \Omega.$$

Hence Ω is an eigenstate of $t(u)$ with the eigenvalue $\sinh(u + \eta)^N + \sinh(u)^N$. The highest weight eigenstates are given in the form of

$$\Phi_{\{v_1, \dots, v_M\}} = B(v_1) \dots B(v_M)\Omega.$$

In order to compute the action of $t(u)$ on $\Phi_{\{v_1, \dots, v_M\}}$, the commutation relations between $A(u)$, $D(u)$ and $B(u)$ are needed, which can be obtained by restricting the input and the output of the auxiliary spaces V_0 and $V_{0'}$ in the relation (3.4). Let the components of the R -matrix be denoted as

$$a(u) = \sinh(u + \eta), b(u) = \sinh(u), c(u) = \sinh(\eta).$$

Using the above notations, the relevant commutation relations are

$$A(u)B(v) = \frac{a(v-u)}{b(v-u)}B(v)A(u) - \frac{c(v-u)}{b(v-u)}B(u)A(v), \quad (3.8)$$

$$D(u)B(v) = \frac{a(u-v)}{b(u-v)}B(v)D(u) - \frac{c(u-v)}{b(u-v)}B(u)D(v), \quad (3.9)$$

$$[B(u), B(v)] = 0. \quad (3.10)$$

The action of $t(u)$ on $\Phi_{\{v_1, \dots, v_M\}}$ is calculated in [77] using the above relations. Using the first relation, $A(u)$ can be commuted through $B(v_1) \dots B(v_M)$, the result is a linear combination of $B(v'_1) \dots B(v'_M)A(v'_{M+1})$, where $\{v'_1, \dots, v'_{M+1}\}$ is any permutation of $\{v_1, \dots, v_M, u\}$. By the relation (3.10), it follows that $B(v'_1) \dots B(v'_M)A(v'_{M+1})$

is only determined by the parameter of the operator A . Choosing the first term on the right hand side of (3.8) every time when commuting $A(u)$ through $B(v_1) \dots B(v_M)$ will give the state $B(v_1) \dots B(v_M)A(u)$, with coefficients $\prod_{k=1}^M \frac{a(v_k - u)}{b(v_k - u)}$. In order to obtain the coefficient of $\prod_{i=1, i \neq k}^M B(v_i)B(u)A(v_k)$, the relation (3.10) will be used to write $A(u)\prod_{i=1}^M B(v_i)$ as $A(u)B(v_k)\prod_{i=1, i \neq k}^M B(v_i)$. Choosing the second term on the right hand side of (3.8) when commuting $A(u)$ and $B(v_k)$, and choosing the first term when commuting $A(u)$ with the rest of $B(v_i)$. This is the only way to obtain $\prod_{i=1, i \neq k}^M B(v_i)B(u)A(v_k)$ from $A(u)B(v_k)\prod_{i=1, i \neq k}^M B(v_i)$. Hence the coefficient of $\prod_{i=1, i \neq k}^M B(v_i)B(u)A(v_k)$ is

$$-\frac{c(v_k - u)}{b(v_k - u)} \prod_{i=1, i \neq k}^M \frac{a(v_i - v_k)}{b(v_i - v_k)}.$$

It will be denoted as $M_k(u)_{\{v_1, \dots, v_M\}}$. Hence all the coefficients of all the possible terms when commuting $A(u)$ through $B(v_1) \dots B(v_M)$ have been calculated

$$\begin{aligned} A(u)\prod_{i=1}^M B(v_i) &= \prod_{k=1}^M \frac{a(v_k - u)}{b(v_k - u)} \prod_{i=1}^M B(v_i)A(u) \\ &+ \sum_{k=1}^M (M_k(u)_{\{v_1, \dots, v_M\}} \prod_{i=1, i \neq k}^M B(v_i)B(u)A(v_k)), \end{aligned}$$

and

$$\begin{aligned} A(u)\prod_{i=1}^M B(v_i)\Omega &= \left(\prod_{k=1}^M \frac{a(v_k - u)}{b(v_k - u)} \right) \sinh(u + \eta)^N \prod_{i=1}^M B(v_i)\Omega \\ &+ \sum_{k=1}^M (M_k(u)_{\{v_1, \dots, v_M\}} \sinh(u_k + \eta)^N \prod_{i=1, i \neq k}^M B(v_i)B(u))\Omega. \end{aligned}$$

Using relations (3.9) and (3.10), it follows from similar argument that

$$\begin{aligned} D(u)\prod_{i=1}^M B(v_i)\Omega &= \left(\prod_{k=1}^M \frac{a(u - v_k)}{b(u - v_k)} \right) \sinh(u)^N \prod_{i=1}^M B(v_i)\Omega \\ &+ \sum_{k=1}^M (N_k(u)_{\{v_1, \dots, v_M\}} \sinh(u_k)^N \prod_{i=1, i \neq k}^M B(v_i)B(u))\Omega, \end{aligned}$$

where

$$N_k(u)_{\{v_1, \dots, v_M\}} = -\frac{c(u - v_k)}{b(u - v_k)} \prod_{i=1, i \neq k}^M \frac{a(v_k - v_i)}{b(v_k - v_i)}.$$

Hence $\Phi_{\{v_1, \dots, v_M\}}$ is an eigenstate of $t(u)$ when the terms $\prod_{i=1, i \neq k}^M B(v_i)B(u)\Omega$ vanish for all k , which gives conditions

$$M_k(u)_{\{v_1, \dots, v_M\}} \sinh(v_k + \eta)^N + N_k(u)_{\{v_1, \dots, v_M\}} \sinh(v_k)^N = 0,$$

with

$$k = 1, \dots, M. \tag{3.11}$$

The conditions (3.11) will be called Bethe equations. When these conditions hold, the eigenvalue of the eigenstate $\prod_{i=1}^M B(v_i)\Omega$ is

$$\alpha^N(u) \prod_{k=1}^M \frac{a(v_k - u)}{b(v_k - u)} + \delta^N(u) \prod_{k=1}^M \frac{a(u - v_k)}{b(u - v_k)}.$$

In [77], it has been proved that repeated Bethe roots do not exist. This is similar to the Pauli exclusion principle, i.e. two fermions can not occupy the same position. In the algebraic Bethe ansatz, the reference state is empty, and the creation operator $B(u)$ creates a pseudo-particle with momentum parametrised by u . Hence the eigenstate with Bethe roots $\{v_1, \dots, v_M\}$ has M pseudo-particle with momenta $\{v_1, \dots, v_M\}$, and they are all different.

3.4 The Algebraic Bethe Ansatz for Open Boundary Conditions

To construct the transfer matrix for the open chain, other matrices called K -matrices are needed, and they are denoted as $K^+(u)$ and $K^-(u)$. They act on the auxiliary space.

$$K^\pm(u) : V \rightarrow V.$$

The diagram of the K -matrices are

$$K^-(u) \sim \begin{array}{c} \text{u} \\ \text{---} \\ \bullet \\ \text{---} \\ \text{-u} \end{array},$$

and

$$K^+(u) \sim \begin{array}{c} \text{u} \\ \text{---} \\ \bullet \\ \text{---} \\ \text{-u} \end{array}.$$

In this section, K -matrices will be chosen as

$$K^-(u) = \begin{bmatrix} \sinh(u + \zeta_-) & 0 \\ 0 & -\sinh(u - \zeta_-) \end{bmatrix},$$

$$K^+(u) = \begin{bmatrix} \sinh(u + \eta + \zeta_+) & 0 \\ 0 & -\sinh(u + \eta - \zeta_+) \end{bmatrix}.$$

Using the Lax operator and the K -matrices, the transfer matrix $t(u)$ can be constructed

$$t(u) \equiv \text{tr} U^+(u) U^-(u),$$

where

$$U^+(u) := K_0^+(u),$$

$$U^-(u) := M(u) K_0^-(u) \widehat{M}(u).$$

The monodromy matrix $M(u)$ is defined as the same as in the periodic case. $\widehat{M}(u)$ is

$$\widehat{M}(u) = L_{1,0}(u) \dots L_{N,0}(u).$$

Remark. This definition of $t(u)$ is different than the original construction by Sklyanin. The transfer matrix can be obtained from the Sklyanin's Hamiltonian by a

shift of the argument $u' = u - \frac{\eta}{2}$, a shift of the parameter in Lax operator $u'_n = u_n - \frac{\eta}{2}$ and multiplying by a scalar function at the same time. Hence all the commutation relations between \mathcal{A} , \mathcal{B} , \mathcal{C} and \mathcal{D} in [25] are still true for the transfer matrix in this section.

The diagram of $\widehat{M}_N(u)$ is

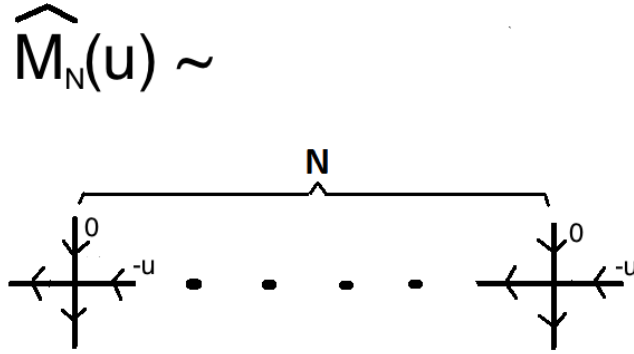

Combining the diagrams of $M(u)$, $\widehat{M}(u)$ and $K^-(u)$ gives the diagram of $U^-(u)$

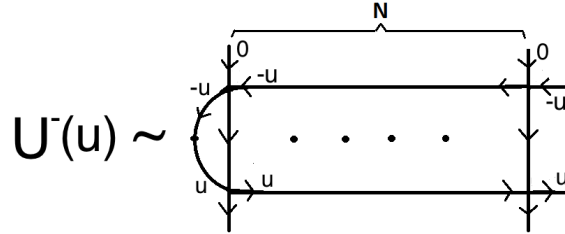

From now on, spectral parameters and arrows will be suppressed in the diagrams.

$U_-(u)$ can be written out in the auxiliary space as

$$U^-(u) = \begin{bmatrix} \mathcal{A}(u) & \mathcal{B}(u) \\ \mathcal{C}(u) & \mathcal{D}(u) \end{bmatrix}.$$

Hence the transfer matrix can be written as

$$t(u) = \sinh(u + \eta + \zeta_+) \mathcal{A}(u) - \sinh(u + \eta - \zeta_+) \mathcal{D}(u).$$

By fixing the input and the output on the auxiliary space of $U^-(u)$ to be $(+)$ and $(+)$, the diagram of the operator $\mathcal{A}_N(u)$ will be obtained

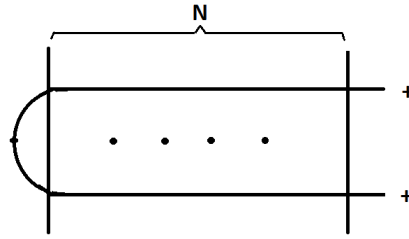

The diagram of operator $\mathcal{B}_N(u)$ is

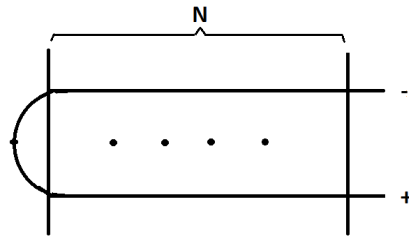

The diagram of the operator $\mathcal{C}_N(u)$ is

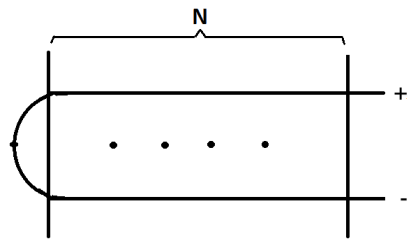

The diagram of the operator $\mathcal{D}_N(u)$ is

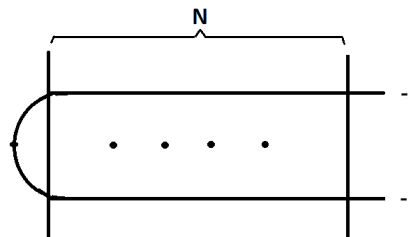

Commas will be used to denote sum of different diagrams. For example, the sum of diagrams $\mathcal{B}_N(u) + \mathcal{C}_N(u)$ is

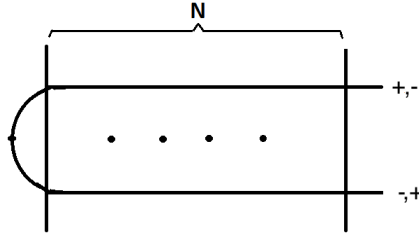

Using diagrams, it will be easier to check the actions of $\mathcal{A}(u)$, $\mathcal{C}(u)$ and $\mathcal{D}(u)$ on the reference state Ω . The values of edges of the diagram of $\mathcal{C}(u)\Omega$ can be completed as

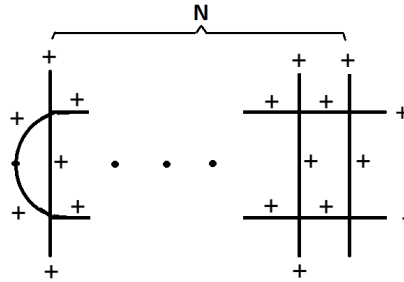

The product of Boltzmann weights of this diagram is zero, no matter what value the bottom-right edge takes. Hence, it follows that

$$\mathcal{C}(u)\Omega = 0.$$

The values of edges of the diagram of $\mathcal{A}(u)\Omega$ can be completed as

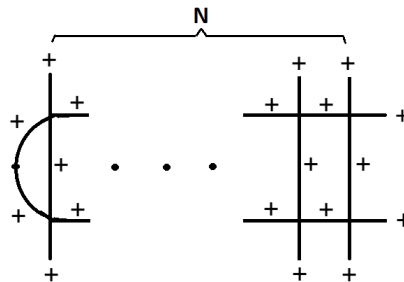

Hence Ω is an eigenvector of $\mathcal{A}(u)$ with the eigenvalue $\alpha(u)$

$$\alpha(u) \equiv \sinh(u + \zeta_-) \sinh(u + \eta)^{2N}.$$

The values of edges of the diagram of $\mathcal{D}(u)\Omega$ can be completed as

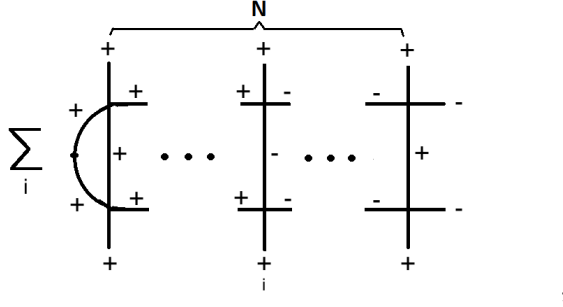

where index i sums over N . Hence Ω is an eigenvector of $\mathcal{D}(u)$ with the eigenvalue

$$\delta(u) \equiv \sinh(u + \zeta_-) \sinh(\eta)^2 \sum_{i=1}^N \sinh(u + \eta)^{2(i-1)} \sinh(u)^{2(N-i)} - \sinh(u - \zeta_-) \sinh(u)^{2N}.$$

The expression of $\delta(u)$ can be simplified as

$$\begin{aligned} \delta(u) &= \sinh(u + \zeta_-) \sinh(\eta)^2 \sinh(u + \eta)^{-2} \sinh(u)^{2N} \sum_{i=1}^N \frac{\sinh(u + \eta)^{2i}}{\sinh(u)^{2i}} - \sinh(u - \zeta_-) \sinh(u)^{2N}, \\ &= \sinh(u + \zeta_-) \sinh(\eta)^2 \sinh(u + \eta)^{-2} \sinh(u)^{2N} \frac{\frac{\sinh(u + \eta)^{2(N+1)}}{\sinh(u)^{2(N+1)}} - \frac{\sinh(u + \eta)^2}{\sinh(u)^2}}{\frac{\sinh(u + \eta)^2}{\sinh(u)^2} - 1} \\ &\quad - \sinh(u - \zeta_-) \sinh(u)^{2N}, \\ &= \sinh(u + \zeta_-) \sinh(\eta)^2 \frac{\sinh(u + \eta)^{2N} - \sinh(u)^{2N}}{\sinh(u + \eta)^2 - \sinh(u)^2} - \sinh(u - \zeta_-) \sinh(u)^{2N}, \\ &= \frac{\sinh(u + \zeta_-) \sinh(\eta)^2}{\sinh(u + \eta)^2 - \sinh(u)^2} \sinh(u + \eta)^{2N} - \frac{\sinh(u + \zeta_-) \sinh(\eta)^2}{\sinh(u + \eta)^2 - \sinh(u)^2} \sinh(u)^{2N} \\ &\quad - \sinh(u - \zeta_-) \sinh(u)^{2N}, \\ &= \frac{\sinh(u + \zeta_-) \sinh(\eta)}{\sinh(2u + \eta)} \sinh(u + \eta)^{2N} \\ &\quad - \frac{\sinh(u + \zeta_-) \sinh(\eta) + \sinh(u - \zeta_-) \sinh(2u + \eta)}{\sinh(2u + \eta)} \sinh(u)^{2N}. \end{aligned}$$

From the above expression, it is easy to check that

$$\delta(u) = \frac{\sinh(\eta) \sinh(u + \zeta_-)}{\sinh(2u + \eta)} \sinh(u + \eta)^{2N} - \frac{\sinh(2u) \sinh(u - \zeta_- + \eta)}{\sinh(2u + \eta)} \sinh(u)^{2N}.$$

These facts will be useful in the algebraic Bethe ansatz of the transfer matrix with open boundary condition.

The important properties of the K -matrices are the reflection equations

$$R_{12}(u_1 - u_2)K_1^-(u_1)R_{12}(u_1 + u_2)K_2^-(u_2) = K_2^-(u_2)R_{12}(u_1 + u_2)K_1^-(u_1)R_{12}(u_1 - u_2), \quad (3.12)$$

and

$$\begin{aligned} & R_{12}(-u_1 + u_2)(K_1^+(u_1))^t R_{12}(-u_1 - u_2 - 2\eta)(K_2^+(u_2))^t \\ &= (K_2^+(u_2))^t R_{12}(-u_1 - u_2 - 2\eta)(K_1^+(u_1))^t R_{12}(-u_1 + u_2). \end{aligned} \quad (3.13)$$

Remark. *As the R -matrix can be constructed as a representation of the universal R -matrix \mathcal{R} , the K -matrices can also be constructed from the co-ideal sub-algebra of quantum groups [78] [79].*

Using the Yang-Baxter equation (3.2) and the reflection equations (3.12) and (3.13), it can be verified that [25]

$$R_{12}(u_1 - u_2)U_1^-(u_1)R_{12}(u_1 + u_2)U_2^-(u_2) = U_2^-(u_2)R_{12}(u_1 + u_2)U_1^-(u_1)R_{12}(u_1 - u_2), \quad (3.14)$$

and

$$\begin{aligned} & R_{12}(-u_1 + u_2)(U_1^+(u_1))^t R_{12}(-u_1 - u_2 - 2\eta)(U_2^+(u_2))^t \\ &= (U_2^+(u_2))^t R_{12}(-u_1 - u_2 - 2\eta)(U_1^+(u_1))^t R_{12}(-u_1 + u_2). \end{aligned} \quad (3.15)$$

Using Yang-Baxter equation (3.2), the crossing symmetry (3.6) and the relation (3.14), the following theorem can be proved [25]

Theorem 4. For any u_1, u_2

$$[t(u_1), t(u_2)] = 0.$$

The algebraic Bethe ansatz of the transfer matrix on the open chain has a similar construction with the closed chain. It starts with the same reference state Ω , and the other eigenstates are constructed in the form of $\mathcal{B}(v_1) \dots \mathcal{B}(v_M)\Omega$. The result of the action of $t(u)$ on $\mathcal{B}(v_1) \dots \mathcal{B}(v_M)\Omega$ is a linear combination of itself and some other states. The requirement that the other states have to vanish will give a system of equations of $\{v_1, \dots, v_M\}$, which is called the Bethe equations. The construction of eigenvalues and eigenstates are given by the following theorem [25]

Theorem 5. The reference state $\Omega \equiv \otimes_{i=1}^N (+)$ is an eigenstate of $t(u)$ with eigenvalue

$$\begin{aligned} \Lambda(u) &= \frac{\sinh(2u + 2\eta)}{\sinh(2u + \eta)} \sinh(u + \zeta_+) \alpha(u) \\ &- \frac{1}{\sinh(2u + \eta)} \sinh(u - \zeta_+ + \eta) (\sinh(2u + \eta) \delta(u) - \sinh(\eta) \alpha(u)). \end{aligned}$$

Other eigenvectors of $t(u)$ are of the form

$$\Phi(u)_{\{v_1, \dots, v_M\}} = \mathcal{B}(v_1) \dots \mathcal{B}(v_M)\Omega,$$

where the set $\{v_1, \dots, v_M\}$ is called Bethe roots, and satisfy conditions

$$\begin{aligned} &\frac{\sinh(v_m + \zeta_+) \sinh(v_m + \zeta_-) \sinh(v_m + \eta)^{2N}}{\sinh(v_m - \zeta_+ + \eta) \sinh(v_m - \zeta_- + \eta) \sinh(v_m)^{2N}} \\ &= \prod_{k=1, k \neq m}^M \frac{\sinh(v_m - v_k + \eta) \sinh(v_m + v_k + 2\eta)}{\sinh(v_m - v_k - \eta) \sinh(v_m + v_k)}, 1 \leq m \leq M. \end{aligned} \quad (3.16)$$

The corresponding eigenvalues are

$$\begin{aligned} \Lambda(u) &= \frac{\sinh(2u + 2\eta)}{\sinh(2u + \eta)} \sinh(u + \zeta_+) \sinh(u + \zeta_-) \sinh(u + \eta)^{2N} \\ &\quad \times \prod_{k=1}^M \frac{\sinh(u - v_k - \eta) \sinh(u + v_k)}{\sinh(u - v_k) \sinh(u + v_k + \eta)} \\ &\quad + \frac{\sinh(2u)}{\sinh(2u + \eta)} \sinh(u - \zeta_+ + \eta) \sinh(u - \zeta_- + \eta) \sinh(u)^{2N} \end{aligned}$$

$$\times \prod_{k=1}^M \frac{\sinh(u - v_k + \eta) \sinh(u + v_k + 2\eta)}{\sinh(u - v_k) \sinh(u + v_k + \eta)}.$$

Proof. Following Sklyanin's proof, the transfer matrix will be rewritten as

$$\frac{\sinh(2u + 2\eta)}{\sinh(2u + \eta)} \sinh(u + \zeta_+) \mathcal{A}(u) - \frac{1}{\sinh(2u + \eta)} \sinh(u - \zeta_+ + \eta) \tilde{\mathcal{D}}(u),$$

where $\tilde{\mathcal{D}}(u) = \sinh(2u + \eta) \mathcal{D}(u) - \sinh \eta \mathcal{A}(u)$. The eigenvalue of $\tilde{\mathcal{D}}(u)$ with reference state Ω is denoted as $\tilde{\delta}(u)$, and it is given as

$$\begin{aligned} \tilde{\delta}(u) &= \sinh(2u + \eta) \delta(u) - \sinh(\eta) \alpha(u), \\ &= -\sinh(2u) \sinh(u - \zeta_- + \eta) \sinh(u)^{2N}. \end{aligned}$$

In order to calculate the action of $t(u)$ on $\mathcal{B}(v_1) \dots \mathcal{B}(v_M) \Omega$, the commutation relations between $\mathcal{A}(u)$, $\mathcal{B}(u)$ and $\tilde{\mathcal{D}}(u)$ are needed. By restricting the input and the output of the tensor product of the two auxiliary spaces to be $(-) \times (+)$ and $(+) \times (+)$ in the relation (3.14), it will give the relation

$$\begin{aligned} \mathcal{A}(u) \mathcal{B}(v) &= \frac{\sinh(u - v - \eta) \sinh(u + v)}{\sinh(u - v) \sinh(u + v + \eta)} \mathcal{B}(v) \mathcal{A}(u) + \frac{\sinh(\eta) \sinh(2v)}{\sinh(u - v) \sinh(2v + \eta)} \mathcal{B}(u) \mathcal{A}(v) \\ &\quad - \frac{\sinh(\eta)}{\sinh(u + v + \eta) \sinh(2v + \eta)} \mathcal{B}(u) \tilde{\mathcal{D}}(v). \end{aligned} \quad (3.17)$$

Restricting the input and the output of the tensor product of the two auxiliary spaces to be $(-) \times (-)$ and $(-) \times (+)$ in the relation (3.14), gives a second commutation relation. After substituting the first relation into the second relation in order to commute the $\mathcal{A}(u)$ and the $\mathcal{B}(v)$ term, it will become

$$\begin{aligned} \tilde{\mathcal{D}}(u) \mathcal{B}(v) &= \frac{\sinh(u - v + \eta) \sinh(u + v + 2\eta)}{\sinh(u - v) \sinh(u + v + \eta)} \mathcal{B}(v) \tilde{\mathcal{D}}(u) \\ &\quad + \frac{\sinh(\eta) \sinh(2u + 2\eta) \sinh(2v)}{\sinh(u + v + \eta) \sinh(2v + \eta)} \mathcal{B}(u) \mathcal{A}(v) - \frac{\sinh(\eta) \sinh(2u + 2\eta)}{\sinh(u - v) \sinh(2v + \eta)} \mathcal{B}(u) \tilde{\mathcal{D}}(v). \end{aligned} \quad (3.18)$$

It is easy to see that the results of $\mathcal{A}(u)$ commuting through $\mathcal{B}(v_1) \dots \mathcal{B}(v_M) \Omega$ have

to have the form

$$\begin{aligned} \mathcal{A}(u)\mathcal{B}(v_1)\dots\mathcal{B}(v_M)\Omega &= \hat{a}\mathcal{B}(v_1)\dots\mathcal{B}(v_M)\mathcal{A}(u)\Omega \\ &+ \sum_{i=1}^M b_i\mathcal{B}(v_1)\dots\mathcal{B}(u)\dots\mathcal{B}(v_M)\mathcal{A}(v_i)\Omega + \sum_{i=1}^M c_i\mathcal{B}(v_1)\dots\mathcal{B}(u)\dots\mathcal{B}(v_M)\tilde{\mathcal{D}}(v_i)\Omega, \end{aligned}$$

where

$$\hat{a} \equiv \prod_{i=1}^M \frac{\sinh(u - v_i - \eta) \sinh(u + v_i)}{\sinh(u - v_i) \sinh(u + v_i + \eta)}.$$

The most convenient way to obtain coefficients b_i and c_i is to use commutativity $[\mathcal{B}(u), \mathcal{B}(v)] = 0$. Here b_i is the sum of the coefficients of all states on the right hand side of the above equation with the form $\mathcal{B}(v_1)\dots\mathcal{B}(u)\dots\mathcal{B}(v_M)\mathcal{A}(v_i)\Omega$. In order to simplify the calculation of the coefficient b_i , $\mathcal{B}(v_1)\dots\mathcal{B}(v_M)\Omega$ will be rearranged into $\mathcal{B}(v_i)\mathcal{B}(v_1)\dots\mathcal{B}(v_M)\Omega$. When $\mathcal{A}(u)$ is commuted all the way to the left in this rearranged state, there will only be one term on the right hand side with the form $\mathcal{B}(v_1)\dots\mathcal{B}(u)\dots\mathcal{B}(v_M)\mathcal{A}(v_i)\Omega$. In order to obtain this term, the second term on the right hand side of the relation (3.17) has to be chosen when commuting with $\mathcal{B}(v_i)$, then the first term on the right hand side of the relation (3.17) has to be chosen when commuting through the rest of the \mathcal{B} operators. A similar argument will work for c_i . Hence the results are

$$\begin{aligned} b_i &\equiv \frac{\sinh(\eta) \sinh(2v_i)}{\sinh(u - v_i) \sinh(2v_i + \eta)} \prod_{k=1, k \neq i}^M \frac{\sinh(v_i - v_k - \eta) \sinh(v_i + v_k)}{\sinh(v_i - v_k) \sinh(v_i + v_k + \eta)}, \\ c_i &\equiv -\frac{\sinh(\eta)}{\sinh(u + v_i + \eta) \sinh(2v_i + \eta)} \prod_{k=1, k \neq i}^M \frac{\sinh(v_i - v_k - \eta) \sinh(v_i + v_k)}{\sinh(v_i - v_k) \sinh(v_i + v_k + \eta)}. \end{aligned}$$

Similarly, when $\mathcal{D}(u)$ commutes through $\mathcal{B}(v_1)\dots\mathcal{B}(v_M)\Omega$, it has to have the form

$$\begin{aligned} \tilde{\mathcal{D}}(u)\mathcal{B}(v_1)\dots\mathcal{B}(v_M)\Omega &= \hat{d}\mathcal{B}(v_1)\dots\mathcal{B}(v_M)\tilde{\mathcal{D}}(u)\Omega \\ &+ \sum_{i=1}^M e_i\mathcal{B}(v_1)\dots\mathcal{B}(u)\dots\mathcal{B}(v_M)\mathcal{A}(v_i)\Omega + \sum_{i=1}^M f_i\mathcal{B}(v_1)\dots\mathcal{B}(u)\dots\mathcal{B}(v_M)\tilde{\mathcal{D}}(v_i)\Omega, \end{aligned}$$

where

$$\hat{d} \equiv \prod_{i=1}^M \frac{\sinh(u - v_i + \eta) \sinh(u + v_i + 2\eta)}{\sinh(u - v_i) \sinh(u + v_i + \eta)},$$

$$e_i \equiv \frac{\sinh(\eta) \sinh(2u + 2\eta) \sinh(2v_i)}{\sinh(u + v_i + \eta) \sinh(2v_i + \eta)} \prod_{k=1, k \neq i}^M \frac{\sinh(v_i - v_k + \eta) \sinh(v_i + v_k + 2\eta)}{\sinh(v_i - v_k) \sinh(v_i + v_k + \eta)},$$

$$f_i \equiv -\frac{\sinh(\eta) \sinh(2u + 2\eta)}{\sinh(u - v_i) \sinh(2v_i + \eta)} \prod_{k=1, k \neq i}^M \frac{\sinh(v_i - v_k + \eta) \sinh(v_i + v_k + 2\eta)}{\sinh(v_i - v_k) \sinh(v_i + v_k + \eta)}.$$

For $\mathcal{B}(v_1) \dots \mathcal{B}(v_M)\Omega$ to be an eigenstate, the overall coefficients of other terms have to vanish for all i , hence

$$\left(\frac{\sinh(2u + 2\eta)}{\sinh(2u + \eta)} \sinh(u + \zeta_+) b_i - \frac{1}{\sinh(2u + \eta)} \sinh(u - \zeta_ + \eta) e_i \right) \alpha(v_i)$$

$$+ \left(\frac{\sinh(2u + 2\eta)}{\sinh(2u + \eta)} \sinh(u + \zeta_+) c_i - \frac{1}{\sinh(2u + \eta)} \sinh(u - \zeta_ + \eta) f_i \right) \tilde{\delta}(v_i) = 0.$$

Multiplying $\sinh(u - v_i)$ on both sides and taking $u = v_i$ gives

$$\frac{\sinh(2v_i + 2\eta) \sinh(2v_i) \sinh(\eta) \sinh(v_i + \zeta_+) \sinh(v_i + \zeta_-)}{\sinh(2v_i + \eta) \sinh(2v_i + \eta)}$$

$$\times \prod_{k=1, k \neq i}^M \frac{\sinh(v_i - v_k - \eta) \sinh(v_i + v_k)}{\sinh(v_i - v_k) \sinh(v_i + v_k + \eta)} \sinh(v_i + \eta)^{2N}$$

$$= \frac{\sinh(2v_i + 2\eta) \sinh(2v_i) \sinh(\eta) \sinh(v_i - \zeta_ + \eta) \sinh(v_i - \zeta_- + \eta)}{\sinh(2v_i + \eta) \sinh(2v_i + \eta)}$$

$$\times \prod_{k=1, k \neq i}^M \frac{\sinh(v_i - v_k + \eta) \sinh(v_i + v_k + 2\eta)}{\sinh(v_i - v_k) \sinh(v_i + v_k + \eta)} \sinh(v_i)^{2N},$$

for all i . This equation can be simplified as

$$\frac{\sinh(v_i + \zeta_+) \sinh(v_i + \zeta_-) \sinh(v_i + \eta)^{2N}}{\sinh(v_i - \zeta_ + \eta) \sinh(v_i - \zeta_- + \eta) \sinh(v_i)^{2N}}$$

$$= \prod_{k=1, k \neq i}^M \frac{\sinh(v_i - v_k + \eta) \sinh(v_i + v_k + 2\eta)}{\sinh(v_i - v_k - \eta) \sinh(v_i + v_k)},$$

for all i . These are the Bethe equations. □

Remark. *The algebraic Bethe ansatz can be applied to the spin chain Hamiltonians of higher spins. The details can be found in [80] [81].*

One of the important objects related to $t(u)$ is $t'(0)$. The Taylor expansion of

$t(u)$ around zero is

$$t(u) = t(0) + t'(0)u + t^{(2)}(0)\frac{u^2}{2!} + \dots$$

The commutativity of the transfer matrix gives

$$[t'(0), t(v)] = 0.$$

The XXZ spin chain Hamiltonian $H_{XXZ, Sklyanin}^{(N)}$ will be defined by $t'(0)$. The following relations are true

$$R_{i,j}(0) = \sinh(\eta)\mathbb{P}_{i,j}, L_n(0) = R_{n,n+1}(0), K^-(0) = \sinh(\zeta_-)\mathbb{I}.$$

Using the above relations, $t'(0)$ can be written as

$$\begin{aligned} t'(0) &= \frac{d}{du}(tr_0(K_0^+(u)M(u)K_0^-(u)\hat{M}(u)))|_{u=0}, \\ &= \sinh(\eta)^{2N}tr_0((K_0^+(0))'\mathbb{P}_{N,0}\dots\mathbb{P}_{1,0}K_0^-(0)\mathbb{P}_{1,0}\dots\mathbb{P}_{N,0}) \\ &+ \sinh(\eta)^{2N-1}\sum_{i=1}^N tr_0(K_0^+(0)\mathbb{P}_{N,0}\dots\mathbb{P}_{i+1,0}\left(\frac{d}{du}R_{i,0}(u)\right)|_{u=0})\mathbb{P}_{i-1,0}\dots\mathbb{P}_{1,0}K_0^-(u)\mathbb{P}_{1,0}\dots\mathbb{P}_{N,0}) \\ &\quad + \sinh(\eta)^{2N}tr_0(K_0^+(0)\mathbb{P}_{N,0}\dots\mathbb{P}_{1,0}(K_0^-(0))'\mathbb{P}_{1,0}\dots\mathbb{P}_{N,0}) \\ &+ \sinh(\eta)^{2N-1}\sum_{i=1}^N tr_0(K_0^+(0)\mathbb{P}_{N,0}\dots\mathbb{P}_{1,0}K_0^-(u)\mathbb{P}_{1,0}\dots\mathbb{P}_{i-1,0}\left(\frac{d}{du}R_{i,0}(u)\right)|_{u=0})\mathbb{P}_{i+1,0}\dots\mathbb{P}_{N,0}), \\ &= \sinh(\zeta_-)\sinh(\eta)^{2N}tr_0((K_0^+(0))') + \sinh(\zeta_-)\sinh(\eta)^{2N-1}\sum_{i=1}^{N-1} tr_0K_0^+(0)\frac{d}{du}R_{i,i+1}(u)|_{u=0}\mathbb{P}_{i,i+1} \\ &\quad + \sinh(\zeta_-)\sinh(\eta)^{2N-1}tr_0K_0^+(0)\frac{d}{du}R_{N,0}(u)|_{u=0}\mathbb{P}_{N,0} + \sinh(\eta)^{2N}tr_0K_0^+(0)(K_1^-(0))' \\ &\quad + \sinh(\zeta_-)\sinh(\eta)^{2N-1}\sum_{i=1}^{N-1} tr_0K_0^+(0)\mathbb{P}_{i,i+1}\frac{d}{du}R_{i,i+1}(u)|_{u=0} \\ &\quad + \sinh(\zeta_-)\sinh(\eta)^{2N-1}tr_0K_0^+(0)\mathbb{P}_{N,0}\frac{d}{du}R_{N,0}(u)|_{u=0}. \end{aligned}$$

Hence $H_{XXZ,Sklyanin}^{(N)} \equiv t'(0)$ is

$$\begin{aligned}
 H_{XXZ,Sklyanin}^{(N)} = & c \left(\sum_{j=1}^{N-1} (\sigma_j^x \sigma_{j+1}^x + \sigma_j^y \sigma_{j+1}^y + \cosh(\eta) \sigma_j^z \sigma_{j+1}^z) + \sinh(\eta) (\sigma_1^z \coth \zeta_- + \sigma_N^z \coth \zeta_+) \right) \\
 & + c' \mathbb{I},
 \end{aligned} \tag{3.19}$$

where

$$\begin{aligned}
 c &= 2 \cosh(\eta) \sinh(\zeta_-) \sinh(\zeta_+) \sinh(\eta)^{2N-1}, \\
 c' &= 2(N-1) \cosh^2(\eta) \sinh(\zeta_-) \sinh(\zeta_+) \sinh(\eta)^{2N-1} \\
 &\quad + 2 \cosh(2\eta) \sinh(\zeta_-) \sinh(\zeta_+) \sinh(\eta)^{2N-1}.
 \end{aligned}$$

This is the Hamiltonian for the spin-half XXZ spin chain on the open boundary condition.

3.5 TQ equations and Baxter's Q-operator

The spectral problem of the transfer matrix of non-diagonal K -matrices can not be solved using the algebraic Bethe ansatz, since it is more difficult to find a reference state. One way to solve the spectral problem is proposed in [82], which uses the vertex-face correspondence to find the reference state. Another way is the TQ equations discovered by R.Baxter [5]. The TQ equation is the relation

$$t(u)\mathcal{Q}(u) = h_1(u)\mathcal{Q}(u + \eta) + h_2(u)\mathcal{Q}(u - \eta),$$

where $h_1(u)$ and $h_2(u)$ are quasi-periodic functions, and $\mathcal{Q}(u)$ satisfy

$$[t(u), \mathcal{Q}(v)] = 0,$$

$$[\mathcal{Q}(u), \mathcal{Q}(v)] = 0.$$

$\mathcal{Q}(u)$ will be called the Q -operator. Let the eigenvalue of the transfer matrix and the Q -operator be denoted as $\Lambda(u)$ and $\bar{\mathcal{Q}}(u)$. By the commutativity relation, $t(u)$ and $\mathcal{Q}(u)$ can be diagonalised simultaneously. Hence

$$\Lambda(u)\bar{\mathcal{Q}}(u) = h(u + \eta)^N \bar{\mathcal{Q}}(u + \eta) + h(u - \eta)^N \bar{\mathcal{Q}}(u - \eta). \quad (3.20)$$

Hence the spectrum of the transfer matrix can be obtained from the spectrum of $Q(u)$.

To obtain the TQ equations of the transfer matrix with non-diagonal K -matrices, the fusion relation are needed [74]. These relations are functional relations between transfer matrices of different spins. In Subsection 3.5.1, the transfer matrices of the integer and half-integer spins and the fusion relations will be introduced. In Subsection 3.5.2, TQ equations will be derived using the fusion relations. These TQ equations are only valid under certain conditions of the boundary parameters.

3.5.1 Fusion Hierarchy

The fusion procedure will be introduced, which is a way to generalise the R -matrix and the K -matrices to higher spin auxiliary spaces [83] [84]. The fused spin- (j, s) R -matrix ($j, s = 1/2, 1, 3/2, \dots$) is given by

$$R_{\{a\}, \{b\}}^{j,s}(u) = P_{\{a\}}^+ P_{\{b\}}^+ \prod_{k=1}^{2j} \prod_{l=1}^{2s} R_{a_k, b_l}^{\frac{1}{2}, \frac{1}{2}}(u + (k + l - j - s - 1)\eta) P_{\{a\}}^+ P_{\{b\}}^+. \quad (3.21)$$

where $\{a\} = \{a_1, \dots, a_{2j}\}$, $\{b\} = \{b_1, \dots, b_{2s}\}$, and $a_1, \dots, a_{2j}, b_1, \dots, b_{2s}$ are the index of spaces. For example, $R_{a_k, b_l}^{\frac{1}{2}, \frac{1}{2}}(u)$ will act on $V_{a_k} \otimes V_{b_l}$, and the space V_{a_k} and V_{b_l} for all k and l are copies of \mathbb{C}^2 . The matrix $R^{\frac{1}{2}, \frac{1}{2}}(u)$ is the same as (3, 1), and the R -matrix in (3.21) is ordered by increasing of k and l . $P_{\{a\}}^+$ is the completely symmetric projector

$$P_{\{a\}}^+ = \frac{1}{(2j)!} \prod_{k=1}^{2j} \left(\sum_{l=1}^k \mathcal{P}_{a_l, a_k} \right),$$

where \mathcal{P} is the permutation operator with $\mathcal{P}_{a_k, a_k} \equiv 1$. The fused spin- j K -matrix $K_{\{a\}}^{-(j)}(u)$ is given by

$$K_{\{a\}}^{-(j)}(u) = P_{\{a\}}^+ \prod_{k=1}^{2j} (\prod_{l=1}^{k-1} R_{a_l, a_k}^{\frac{1}{2}, \frac{1}{2}}(2u + (k+l-2j-1)\eta)) K_{a_k}^{-(\frac{1}{2})}(u + (k-j-\frac{1}{2})\eta) P_{\{a\}}^+. \quad (3.22)$$

The product in (3.22) is ordered by increasing of k and l . The matrix $K^{-(\frac{1}{2})}(u)$ is defined by its entries as

$$K_{11}^{-(\frac{1}{2})}(u) = 2(\sinh(\alpha_-) \cosh(\beta_-) \cosh(u) + \cosh(\alpha_-) \sinh(\beta_-) \sinh(u)),$$

$$K_{22}^{-(\frac{1}{2})}(u) = 2(\sinh(\alpha_-) \cosh(\beta_-) \cosh(u) - \cosh(\alpha_-) \sinh(\beta_-) \sinh(u)),$$

$$K_{12}^{-(\frac{1}{2})}(u) = e^{\theta_-} \sinh(2u),$$

$$K_{21}^{-(\frac{1}{2})}(u) = e^{\theta_-} \sinh(2u),$$

where α_{\pm} , β_{\pm} and θ_{\pm} are arbitrary boundary parameters. The fused spin- j K -matrix $K_{\{a\}}^{+(j)}(u)$ is given by

$$K_{\{a\}}^{+(j)}(u) = \frac{1}{f^{(j)}(u)} K_{\{a\}}^{-(j)}(-u - \eta)|_{(\alpha_-, \beta_-, \theta_-) \rightarrow (-\alpha_+, -\beta_+, \theta_+)}, \quad (3.23)$$

where the scalar functions $f^{(j)}(u)$ are

$$f^{(j)}(u) = \prod_{l=1}^{2j-1} \prod_{k=1}^l (-\xi(2u + (l+k+1-2j)\eta)),$$

where $\xi(u) = \sinh(u + \eta) \sinh(u - \eta)$. The fused transfer matrix $t^{(j,s)}(u)$ with a spin- j auxiliary space is given by

$$t^{(j,s)}(u) = \text{tr}_{\{a\}} (K_{\{a\}}^{+(j)}(u) T_{\{a\}}^{(j,s)}(u) K_{\{a\}}^{-(j)}(u) \hat{T}_{\{a\}}^{(j,s)}(u)),$$

where the monodromy matrix is given by product of fused R -matrices:

$$T_{\{a\}}^{(j,s)}(u) = R_{\{a\}, \{b^{[N]}\}}^{j,s}(u) \dots R_{\{a\}, \{b^{[1]}\}}^{j,s}(u),$$

$$\hat{T}_{\{a\}}^{(j,s)}(u) = R_{\{a\},\{b^{[1]}\}}^{j,s}(u) \cdots R_{\{a\},\{b^{[N]}\}}^{j,s}(u),$$

where $\{b^{[i]}\}, i = 1, \dots, N$ are N sets of index. The fused transfer matrices satisfy commutativity relations

$$[t^{(j,s)}(u), t^{(k,s)}(u')] = 0.$$

This is true for any different values of spectral parameters u and u' , and any values of $j, k = \frac{1}{2}, 1, \frac{3}{2}, \dots$, and any spin $s = \frac{1}{2}, 1, \frac{3}{2}, \dots$. They also satisfy the functional relations called the fusion hierarchy

$$t^{(j-\frac{1}{2},s)}(u - j\eta)t^{(\frac{1}{2},s)}(u) = t^{(j,s)}(u - (j - \frac{1}{2})\eta) + \delta^{(s)}(u)t^{(j-1,s)}(u - (j + \frac{1}{2})\eta), \quad (3.24)$$

where $t^{(0,s)}(u) = 1$, and $\delta^{(s)}(u)$ is given by

$$\delta^{(s)}(u) = 2^4 (\prod_{k=0}^{2s-1} \xi(u + (s - k - \frac{1}{2})\eta))^{2N} \frac{\sinh(2u - 2\eta) \sinh(2u + 2\eta)}{\sinh(2u - \eta) \sinh(2u + \eta)}$$

$$\begin{aligned} & \times \sinh(u + \alpha_-) \sinh(u - \alpha_-) \cosh(u + \beta_-) \cosh(u - \beta_-) \sinh(u + \alpha_+) \sinh(u - \alpha_+) \\ & \times \cosh(u + \beta_+) \cosh(u - \beta_+). \end{aligned}$$

3.5.2 TQ equation

Motivated by [36], the TQ equations for the transfer matrix with the open boundary condition is found [74], where the Q -operator has the expression

$$\mathcal{Q}(u) = \lim_{j \rightarrow \infty} t^{(j-\frac{1}{2},s)}(u - j\eta),$$

where $t^{(j-\frac{1}{2},s)}(u)$ is the fused spin- s transfer matrix with the spin- j auxiliary space. This definition of $\mathcal{Q}(u)$ is formal, since the limit on the right hand side does not exist. However, it will not be used directly. This definition together with functional relations between the fused transfer matrix with different auxiliary spaces gives a formal TQ equations. Using this formal TQ equations between operators, the TQ equations for the corresponding eigenvalues can be obtained. The scalar functions

in the TQ equations for the corresponding eigenvalues can be carefully chosen such that these equations give the correct numerical solutions of eigenvalues.

By taking the limit $j \rightarrow \infty$ in the fusion hierarchy (3.24), it becomes

$$t^{(\frac{1}{2},s)}(u)Q(u) = Q(u + \eta) + \delta^{(s)}(u)Q(u - \eta).$$

Let the eigenvalues corresponding to the same eigenstate of $Q(u)$ and $t^{(\frac{1}{2},s)}(u)$ be denoted as $\bar{Q}(u)$ and $\Lambda^{(\frac{1}{2},s)}(u)$. Then the above relation suggests the following relation

$$\Lambda^{(\frac{1}{2},s)}(u) = \frac{\bar{Q}(u + \eta)}{\bar{Q}(u)} + \delta(u) \frac{\bar{Q}(u - \eta)}{\bar{Q}(u)}.$$

Assume the form of $\bar{Q}(u)$ is

$$\bar{Q}(u) = f(u)Q(u),$$

where $f(u)$ is a scalar function, and

$$Q(u) = \prod_{j=1}^M \sinh(u - u_j) \sinh(u + u_j + \eta). \quad (3.25)$$

Let $H_1(u) = \frac{f(u+\eta)}{f(u)}$ and $H_2(u) = \delta^{(s)}(u) \frac{f(u-\eta)}{f(u)}$. Then $\Lambda(u)$ can be expressed as

$$\Lambda^{(\frac{1}{2},s)}(u) = H_1(u) \frac{Q(u + \eta)}{Q(u)} + H_2(u) \frac{Q(u - \eta)}{Q(u)}.$$

There are two set of solutions for H_1 and H_2 in [83]. In this thesis, only one of those solutions will be used, which is

$$H_1(u|\epsilon_1, \epsilon_2, \epsilon_3) = -4\epsilon_2 \left(\prod_{k=0}^{2s-1} \sinh(u + (s - k - \frac{1}{2})\eta) \right)^{2N} \frac{\sinh(2u)}{\sinh(2u + \eta)}$$

$$\times \sinh(u + \alpha_- + \eta) \cosh(u + \epsilon_1\beta_- + \eta) \sinh(u + \epsilon_2\alpha_+ + \eta) \cosh(u + \epsilon_3\beta_+ + \eta),$$

$$H_2(u) = H_1(-u - \eta),$$

with the condition

$$\alpha_- + \epsilon_1\beta_- + \epsilon_2\alpha_+ + \epsilon_3\beta_+ = \epsilon_0(\theta_- - \theta_+) + \eta k + \frac{1 - \epsilon_2}{2} i\pi$$

$$\epsilon_1 \epsilon_2 \epsilon_3 = 1, \quad (3.26)$$

where $\epsilon_1, \epsilon_2, \epsilon_3 \in \{-1, 1\}$. The above equation is true up to mod $2i\pi$, where $k \in \mathbb{Z}$, and $M = sN - \frac{1}{2} - \frac{k}{2}$ is a non-negative integer. Functions H_1 and H_2 satisfy

$$H_1(u - \eta) H_2(u) = \delta^{(s)}(u).$$

This expression satisfies some properties of eigenvalues of the transfer matrix. First, those functions satisfy the initial condition

$$\Lambda^{(\frac{1}{2}, s)}(0) = -8 \sinh(\eta)^{2N} \cosh(\eta) \sinh(\alpha_-) \cosh(\beta_-) \sinh(\alpha_+) \cosh(\beta_+).$$

Second, they satisfy the asymptotic behaviour

$$\Lambda(u)^{(\frac{1}{2}, s)} \sim -\frac{\cosh(\theta_- - \theta_+) e^{(2N+4)u + (N+2)\eta}}{2^{2N+1}} + \dots,$$

for $u \rightarrow +\infty$. This is the condition of boundary parameters in relation (3.26)

$$\alpha_- + \epsilon_1 \beta_- + \epsilon_2 \alpha_+ + \epsilon_3 \beta_+ = \epsilon_0 (\theta_- - \theta_+) + \eta k + \frac{1 - \epsilon_2}{2} i\pi.$$

Finally, the semiclassical property is satisfied

$$\begin{aligned} \Lambda^{(\frac{1}{2}, s)}(u)|_{\eta=0} &= 8 \sinh(u)^{2N} (-\sinh(\alpha_-) \cosh(\beta_-) \sinh(\alpha_+) \cosh(\beta_+) \cosh(u)^2 \\ &+ \cosh(\alpha_-) \sinh(\beta_-) \cosh(\alpha_+) \sinh(\beta_+) \sinh(u)^2 - \cosh(\theta_- - \theta_+) \sinh(u)^2 \cosh(u)^2). \end{aligned}$$

This will give a condition among $\{\epsilon_i\}$

$$\epsilon_1 \epsilon_2 \epsilon_3 = 1.$$

Remark. The Hamiltonian $H_{XXZ, general}^{(N)}$ can be defined as $\frac{d}{du} t^{(\frac{1}{2}, \frac{1}{2})}(u)|_{u=0}$. $H_{XXZ, general}^{(N)}$ corresponds to the transfer matrix constructed from the R -matrix in the relation (3.1) and the non-diagonal K -matrices $K^{-(\frac{1}{2})}(u)$ and $K^{+(\frac{1}{2})}(u)$. The exact expression of

this Hamiltonian can be found in [74].

It is worth noting that $H_{XXZ,general}^{(N)}$ can be identified with the representation of elements of the two boundary Temperley-Lieb algebra [85]. This connection is pointed out in [86] [87] [88]. In the context of the two boundary Temperley-Lieb algebra, the condition (3.22) becomes the restriction on the parameters in the algebra, such that the algebra has a reducible but indecomposable representation. This condition is equivalent to the condition where the determinant of the gram matrix is zero. The gram matrix is also used in the meander model [89] [90].

Chapter 4

Symmetry of Bethe equations

In Section 2.1, the supersymmetric Hamiltonian $H_{XYZ}^{(N)}$ with the closed boundary condition has been constructed. The Hamiltonian $H_{XYZ}^{(N)}$ is related to the transfer matrix of the eight-vertex model. The transfer matrix of the eight-vertex and $H_{XYZ}^{(N)}$ are in the same commuting family, hence they share the same eigenvectors and Bethe equations. In [52], the transfer matrix of the eight-vertex model was studied using the coordinate Bethe ansatz. There is a symmetry in the Bethe equations, which induces a correspondence of eigenvalues of transfer matrices with different size. To be more precise, let $\{v_1, \dots, v_M\}^{(N)}$ be a set of Bethe roots of the transfer matrix of length N , then $\{v_1, \dots, v_M, \eta\}^{(N-1)}$ is a set of Bethe roots of the transfer matrix of length $N - 1$. This correspondence will be denoted by S^{Bethe} . When the eigenstates can be constructed from the Bethe roots, the correspondence in Bethe roots will induce a map S^{Bethe}

$$S_N^{Bethe} : V^{\otimes N} \rightarrow V^{\otimes N-1}, \quad (4.1)$$

with the action of S_N^{Bethe} on eigenstates defined as

$$S_N^{Bethe} \Phi_{\{v_1, \dots, v_N\}}^{(N)} = \Phi_{\{v_1, \dots, v_N, \eta\}}^{(N-1)},$$

where $\Phi_{\{v_1, \dots, v_N\}}^{(N)}$ denote the eigenstate constructed from $\{v_1, \dots, v_N\}$ of the transfer matrix of length N . S^{Bethe} only act on eigenstates constructed from Bethe roots,

hence S^{Bethe} only acts on a certain subspace.

In [69], this symmetry in the Bethe equations of the $gl(n|m)$ spin chains has been studied. In [70], this symmetry in the M_2 model of single fermions and pairs has been studied, and the map S^{Bethe} is identified with the lattice supercharge of this model. In [91], the symmetry of the $N = 4$ Super Yang-Mills model has been studied.

This chapter will study the Bethe equations of the Hamiltonians of the XXZ spin chains with varying boundary matrices, and the analogue of S^{Bethe} for each of them. In Section 4.1, the Hamiltonian of the XXZ spin chain with closed boundary conditions will be studied using the algebraic Bethe ansatz, and part of the result obtained in [52] from the coordinate Bethe ansatz will be recreated. S^{Bethe} only exists in a certain subspace for this Hamiltonian. In Section 4.2 and Section 4.3, the Hamiltonian of the XXZ spin chain with open boundary conditions will be studied. In this case, S^{Bethe} exists on all spaces. Section 4.2 will analyse the integrable open XXZ Hamiltonian with generic boundary matrices using TQ equations. The result shows that the symmetry in TQ equations induces the the map S^{Bethe} . There is a restriction on the boundary parameters, and the TQ equations only exist within this restriction. Section 4.3 will treat the special case of the open XXZ Hamiltonian, which has diagonal boundary matrices. This Hamiltonian is equal to the Hamiltonian defined in Section 4.2 with boundary parameters going to a certain limit. In this limit, the TQ equations are no longer valid. Using the symmetry in the algebraic Bethe ansatz, the existence of the map S^{Bethe} for this Hamiltonian has been proved.

In Section 4.4, a Hamiltonian which has both the lattice supercharge S_N and the map S^{Bethe} will be defined, and the relation between S_N and S^{Bethe} will be studied. This Hamiltonian is a special case studied in Section 4.3. By numerical checks of the action of lattice supercharge S_N on eigenstates constructed from the algebraic Bethe ansatz, it has been found that the lattice supercharge S_N is proportional to S^{Bethe} .

4.1 Bethe Ansatz analysis on closed chain

For $\eta = 2i\pi/3$, the Bethe equations of the transfer matrix $t(u)$ of six-vertex model has an additional symmetry [52]. To see this symmetry, recall the Bethe equations (3.11) of the periodic case

$$M_k(u, \{v_1, \dots, v_M\})\alpha^N(v_k) + N_k(u, \{v_1, \dots, v_M\})\delta^N(v_k) = 0,$$

with

$$k = 1, \dots, M,$$

where the spectral parameter is denoted as u , and the Bethe roots are denoted as $\{v_1, \dots, v_M\}$. The Bethe equations can be written out as

$$\prod_{i=1, i \neq k}^M \frac{\sinh(v_i - v_k + \eta)}{\sinh(v_i - v_k - \eta)} = \frac{\sinh^N(v_k)}{\sinh^N(v_k + \eta)},$$

with

$$k = 1, \dots, M.$$

By using the above equations, it is easy to see the following set of equations are true for $\eta = 2i\pi/3$:

$$\prod_{i=1, i \neq k}^M \frac{\sinh(v_i - v_k + \eta)}{\sinh(v_i - v_k - \eta)} \frac{\sinh(-v_k + 2\eta)}{\sinh(-v_k)} = \frac{\sinh^N(v_k) \sinh(v_k + \eta)}{\sinh^N(v_k + \eta) \sinh(v_k)},$$

with

$$k = 1, \dots, M.$$

The above equations are exactly the first M Bethe equations of lattice size $N - 1$ with Bethe roots $\{v_1, \dots, v_M, \eta\}$. The last equation is

$$\prod_{i=1}^M \frac{\sinh(v_i)}{\sinh(v_i - 2\eta)} = (-1)^{N-1}. \quad (4.2)$$

This can be interpreted as a restriction on eigenstates to a certain eigenspace of $t(0)$. Recall the expression for the eigenvalue

$$\Lambda(u) = \sinh^N(u + \eta) \prod_{k=1}^M \frac{\sinh(v_k - u + \eta)}{\sinh(v_k - u)} + \sinh^N(u) \prod_{k=1}^M \frac{\sinh(u - v_k + \eta)}{\sinh(u - v_k)},$$

hence the condition (4.2) is equal to

$$\Lambda(0) = (-1)^{N-1} \sinh(\eta)^N. \quad (4.3)$$

The transfer matrix $t(u)$ has a symmetry in the Bethe equations when the above condition holds. The Hamiltonian $H_{XXZ}^{(N)}$ of the XXZ chain with periodic condition is related to the transfer matrix as $H_{XXZ}^{(N)} \propto t'(0)$. Since $t(0) = \sinh(\eta)^N T_N$, the relation (4.3) is the same as the restriction on the supersymmetric $H_{XYZ}^{(N)}$ in Section 2.1, which has $H_{XXZ}^{(N)}$ as a special case. Hence the condition for lattice SUSY obtained from Bethe equations is consistent with the condition for lattice SUSY given in [52].

It has been conjectured in [52] that the map S^{Bethe} of $H_{XYZ}^{(N)}$ is equal to a linear combination of S_N and the spin reversed version of it. This conjecture will motivate us to study the relation between S_N and S^{Bethe} for the supersymmetric open XXZ chain Hamiltonian.

4.2 The Open Chain with Non-diagonal Boundary Matrices

This section will examine the spectrum of the integrable open XXZ spin chain Hamiltonian with non-diagonal boundary matrices using TQ equations. The TQ equations of the open XXZ spin chain Hamiltonian with non-diagonal boundary matrices has been studied in [92] [93]. However, it is difficult to analyse the symmetry of the TQ equations in [93]. The difficulty is due the complexity of the TQ equations, where there are two sets of Bethe roots instead of one set. In [74] [83], the TQ equations

have been proposed with only one set of Bethe roots. However, the existence of the TQ equations depends on the boundary parameters of the XXZ Hamiltonian. In [94], it has been suggested that these TQ equations are the special case of the inhomogeneous TQ equations, and the condition for the existence of the TQ equations in [83] is equivalent to the condition where the inhomogeneous term becomes zero in [94].

The TQ equations of the spin- s transfer matrix given in [83] have a symmetry when $\eta = \frac{i\pi}{s+1}$ and $\eta = 0$, which implies the correspondence S^{Bethe} , which takes the set of Bethe roots $\{v_1, \dots, v_N\}$ of transfer matrix of length N to Bethe roots $\{v_1, \dots, v_N, (s + \frac{1}{2})\eta\}$ of transfer matrix of length $N - 1$. Since TQ equations only exist when the boundary parameters of the transfer matrix satisfy the condition proposed in [83], the map will only exist with this condition together with the restriction on the parameter $\eta = \frac{i\pi}{s+1}$ or $\eta = 0$. These results will be proved in the following.

The eigenvalue $\Lambda^{(\frac{1}{2}, s)}(u)$ of the spin- s transfer matrix has the form [83]

$$\Lambda^{(\frac{1}{2}, s)}(u) = H_1(u|\epsilon_1, \epsilon_2, \epsilon_3) \frac{Q(u+\eta)}{Q(u)} + H_2(u|\epsilon_1, \epsilon_2, \epsilon_3) \frac{Q(u-\eta)}{Q(u)}, \quad (4.4)$$

where

$$Q(u) = \prod_{j=1}^M \sinh(u - v_j) \sinh(u + v_j + \eta), \quad M = \frac{1}{2}(2sN - 1 - k),$$

and

$$\begin{aligned} H_1(u|\epsilon_1, \epsilon_2, \epsilon_3) &= -4\epsilon_2 \sinh^{2N}(u - (s - \frac{1}{2})\eta) \frac{\sinh(2u)}{\sinh(2u + \eta)} \sinh(u + \alpha_- + \eta) \cosh(u + \epsilon_1 \beta_- + \eta) \\ &\quad \times \sinh(u + \epsilon_2 \alpha_+ + \eta) \cosh(u + \epsilon_3 \beta_+ + \eta), \\ H_2(u|\epsilon_1, \epsilon_2, \epsilon_3) &= -4\epsilon_2 \sinh^{2N}(u + (s + \frac{1}{2})\eta) \frac{\sinh(2u + 2\eta)}{\sinh(2u + \eta)} \sinh(u - \alpha_-) \cosh(u - \epsilon_1 \beta_-) \\ &\quad \times \sinh(u - \epsilon_2 \alpha_+) \cosh(u - \epsilon_3 \beta_+). \end{aligned}$$

The boundary parameters of this Hamiltonian satisfy the condition

$$\alpha_- + \epsilon_1 \beta_- + \epsilon_2 \alpha_+ + \epsilon_3 \beta_+ = \epsilon_0(\theta_- - \theta_+) + \eta k + \frac{1 - \epsilon_2}{2} i\pi, \quad (4.5)$$

with

$$\epsilon_1 \epsilon_2 \epsilon_3 = 1.$$

The relation (4.5) is true up to mod $2i\pi$, where $k \in \mathbb{Z}$ and $|k| \leq 2sN - 1$. The relation (4.5) comes from the asymptotic behaviour and the semi-classical property of $\Lambda(u)$ [74]. Letting $u = v_j$ in relation (4.4) and using analyticity of $\Lambda(u)$ gives the Bethe equations

$$\frac{H_2(v_j | \epsilon_1, \epsilon_1, \epsilon_3)}{H_2(-v_j - \eta | \epsilon_1, \epsilon_1, \epsilon_3)} = -\frac{Q(v_j + \eta)}{Q(v_j - \eta)},$$

with

$$j = 1, \dots, M.$$

Assuming the map S^{Bethe} exists for the spin- s transfer matrix, the condition (4.5) implies a restriction on η . The map S_N^{Bethe} takes an eigenvector $\Phi_{\{v_1, \dots, v_M\}}^{(N)}$ to another eigenvector $\Phi_{\{v_1, \dots, v_M, (s + \frac{1}{2})\eta\}}^{(N-1)}$, where $\{v_1, \dots, v_M\}$ and $\{v_1, \dots, v_M, (s + \frac{1}{2})\eta\}$ satisfy the TQ equations of length N and $N - 1$ respectively. A necessary condition for TQ equations is the relation (4.5). Hence the relation (4.5) has to be true for both $\{v_1, \dots, v_M\}$ and $\{v_1, \dots, v_M, (s + \frac{1}{2})\eta\}$. For $H_{XXZ, general}^{(N)}$ with size N and $N - 1$, the boundary parameters $\alpha_{\pm}, \beta_{\pm}, \theta_{\pm}$ are fixed, However, the integer k can be different for different sets of Bethe roots. To differentiate the condition (4.5) for different sets of Bethe roots, k and k' will be used in the relation (4.5) of $\{v_1, \dots, v_M\}$ and $\{v_1, \dots, v_M, (s + \frac{1}{2})\eta\}$. Hence the relation (4.5) for $\{v_1, \dots, v_M\}$ and $\{v_1, \dots, v_M, \eta\}$ are

$$\alpha_- + \epsilon_1 \beta_- + \epsilon_2 \alpha_+ + \epsilon_3 \beta_+ = \epsilon_0(\theta_- - \theta_+) + \eta k + \frac{1 - \epsilon_2}{2} i\pi,$$

$$\alpha_- + \epsilon_1 \beta_- + \epsilon_2 \alpha_+ + \epsilon_3 \beta_+ = \epsilon_0(\theta_- - \theta_+) + \eta k' + \frac{1 - \epsilon_2}{2} i\pi,$$

$$\epsilon_1 \epsilon_2 \epsilon_3 = 1.$$

The above equations are true up to mod $2i\pi$, where $k \in \mathbb{Z}$ and $|k| \leq 2sN - 1$. The

integer k in the relation (4.5) is related to the number of Bethe roots and the size of the spin chains by $M = \frac{1}{2}(2sN - 1 - k)$, it follows from this relation that

$$k = -2M + 2sN - 1, k' = -2(M + 1) + 2s(N - 1) - 1.$$

Comparing the two above relations gives

$$k' = k - 2s - 2.$$

Substituting the above relation, the condition (4.5) for $\{v_1, \dots, v_M, (s + \frac{1}{2})\eta\}$ becomes

$$\alpha_- + \epsilon_1\beta_- + \epsilon_2\alpha_+ + \epsilon_3\beta_+ = \epsilon_0(\theta_- - \theta_+) + \eta k - (2s + 2)\eta + \frac{1 - \epsilon_2}{2}i\pi. \quad (4.6)$$

Hence

$$(2s + 2)\eta = 0.$$

The above equation is true up to mod $2i\pi$. This equation gives a restriction on η , and it has solutions $\eta = \pm \frac{i\pi}{s+1}$ and $\eta = 0$.

It remain to be checked that the map S^{Bethe} take an eigenstate to another eigenstate at $\eta = \pm \frac{i\pi}{s+1}$ and $\eta = 0$, i.e. when $\{v_1, \dots, v_M\}$ satisfy Bethe equations of the length N , $\{v_1, \dots, v_M, (s + \frac{1}{2})\eta\}$ will satisfy Bethe equations of the length $N - 1$. Bethe equations of length $N - 1$ with Bethe roots $\{v_1, \dots, v_M, (s + \frac{1}{2})\eta\}$ are

$$\begin{aligned} \frac{\sinh^2(v_j - (s - \frac{1}{2})\eta)}{\sinh^2(v_j + (s + \frac{1}{2})\eta)} &= \frac{\sinh(v_j - (s - \frac{1}{2})\eta) \sinh(v_j + (s + \frac{5}{2})\eta)}{\sinh(v_j - (s + \frac{3}{2})\eta) \sinh(v_j + (s + \frac{1}{2})\eta)}, j = 1, \dots, M, \\ & \frac{\sinh^{2N}((2s + 1)\eta) \sinh((2s + 3)\eta)}{\sinh^{2N}(\eta) \sinh((2s + 1)\eta)} \\ & \times \frac{\sinh((s + \frac{1}{2})\eta - \alpha_-) \cosh((s + \frac{1}{2})\eta - \epsilon_1\beta_-) \sinh((s + \frac{1}{2})\eta - \epsilon_2\alpha_+) \cosh((s + \frac{1}{2})\eta - \epsilon_3\beta_+)}{\sinh((s + \frac{3}{2})\eta + \alpha_-) \cosh((s + \frac{3}{2})\eta + \epsilon_1\beta_-) \sinh((s + \frac{3}{2})\eta + \epsilon_2\alpha_+) \cosh((s + \frac{3}{2})\eta + \epsilon_3\beta_+)} \\ & = \prod_{i=1}^M \frac{\sinh((s + \frac{3}{2})\eta - v_j) \sinh(v_j + (s + \frac{5}{2})\eta)}{\sinh((s - \frac{1}{2})\eta - v_j) \sinh(v_j + (s + \frac{1}{2})\eta)}. \end{aligned} \quad (4.7)$$

It is worth noting that the Bethe equations of $\{v_1, \dots, v_M\}$ of length N have been

used to simplify the $M + 1$ equations in relation (4.7). It is easy to see that all the above $M + 1$ equations are true for $\eta = \pm \frac{i\pi}{s+1}$ and $\eta = 0$. Hence the map S^{Bethe} exists for the transfer matrix when $\eta = \pm \frac{i\pi}{s+1}$ and $\eta = 0$ with boundary parameters satisfying the relation (4.5).

From now on, let $s = \frac{1}{2}$ and $\eta = \frac{2i\pi}{3}$. The Hamiltonian of the spin-half transfer matrix at $\eta = \frac{2i\pi}{3}$ will be normalised, such that S^{Bethe} takes an eigenvector of this normalised Hamiltonian of the length N to another eigenvector of the length $N - 1$ with the same eigenvalue. The definition of the spin-half XXZ chain Hamiltonian with general boundary matrix is

$$H_{XXZ,general}^{(N)} = t'(0) = \frac{\partial t(u)}{\partial u} \Big|_{u=0}.$$

The exact expression of $H_{XXZ,general}^{(N)}$ is not needed in this thesis. The eigenvalues of the Hamiltonian are related to eigenvalues of the transfer matrix as

$$E \equiv (\Lambda^{(\frac{1}{2}, \frac{1}{2})}(0))'.$$

Using the fact that $\frac{\partial H_1(u)}{\partial u} \Big|_{u=0} = H_1(u) \Big|_{u=0} = 0$ and the relation (4.4), the energy has the form

$$\begin{aligned} E &\equiv \frac{\partial}{\partial u} (H_2(u) \frac{Q(u-\eta)}{Q(u)}) \Big|_{u=0}, \\ &= \left(\frac{\partial}{\partial u} (H_2(u)) \frac{Q(u-\eta)}{Q(u)} + H_2(u) \frac{\partial}{\partial u} \left(\frac{Q(u-\eta)}{Q(u)} \right) \right) \Big|_{u=0}, \\ &= \frac{\partial}{\partial u} (H_2(u)) \Big|_{u=0} + H_2(0) \sum_{i=1}^M \frac{\partial}{\partial u} \left(\frac{\sinh(u-v_i-\eta) \sinh(u+v_i)}{\sinh(u-v_i) \sinh(u+v_i+\eta)} \right) \Big|_{u=0}, \\ &= \frac{\partial}{\partial u} (H_2(u)) \Big|_{u=0} + H_2(0) \sum_{i=1}^M \frac{2 \sinh(\eta)}{\sinh(v_i) \sinh(v_i+\eta)}. \end{aligned} \quad (4.8)$$

The exact forms of $H_2(0)$ and $\frac{\partial}{\partial u} (H_2(u)) \Big|_{u=0}$ are not needed in this thesis. The Hamiltonian will be normalised as

$$H_{XXZ,general}^{(N)'} \equiv \frac{H_{XXZ,general}^{(N)}}{H_2(0)} - \frac{\frac{\partial}{\partial u} (H_2(u)) \Big|_{u=0}}{H_2(0)} + \frac{2N}{\sinh(2\eta)}.$$

Hence the eigenvalue E of $H_{XXZ,general}^{(N) \prime}$ is

$$E = \sum_{i=1}^M \frac{2 \sinh(\eta)}{\sinh(v_i) \sinh(v_i + \eta)} + \frac{2N}{\sinh(2\eta)}.$$

For the pair of Bethe roots $\{v_1, \dots, v_M\}_{i=1, \dots, M}$ of the size N chain and $\{v_1, \dots, v_M, \eta\}_{i=1, \dots, M}$ of size $N - 1$, their corresponding eigenvalues $E_{\{v_1, \dots, v_M\}}^{(N)}$ and $E_{\{v_1, \dots, v_M, \eta\}}^{(N-1)}$ are equal

$$\begin{aligned} E_{\{v_1, \dots, v_M\}}^{(N)} &\equiv \sum_{i=1}^M \frac{2 \sinh(\eta)}{\sinh(v_i) \sinh(v_i + \eta)} + \frac{2N}{\sinh(2\eta)}, \\ &= \sum_{i=1}^M \frac{2 \sinh(\eta)}{\sinh(v_i) \sinh(v_i + \eta)} + \frac{2}{\sinh 2\eta} + (N - 1) \frac{2}{\sinh(2\eta)}, \\ &= E_{\{v_1, \dots, v_M, \eta\}}^{(N-1)}. \end{aligned}$$

Hence for the two sets of Bethe roots paired by the map S^{Bethe} , their eigenstates share the same eigenvalue.

Remark. *It is worth noting that S^{Bethe} also exists for $\eta = \pm \frac{i\pi}{2s+2}$ if the boundary parameter θ_+ is allowed to change between Hamiltonians with the odd and the even length. Let $\theta_+ = \theta_-$ for N is odd and $\theta_+ = \theta_- + i\pi$ for N is even. The rest of boundary parameters are left unchanged. Let $\{v_1, \dots, v_M\}$ be a set of Bethe roots satisfying TQ equations of the length N . It is easy to see that the relation (4.7) is true, hence $\{v_1, \dots, v_M, \eta\}$ is a set of Bethe roots satisfying TQ equations of the length $N - 1$. The condition (4.5) is also satisfied for these two sets of Bethe roots. This implies the existence of the map S^{Bethe} .*

For the spin-half Hamiltonian, changing the boundary parameter θ_+ between Hamiltonians with the odd and the even lengths simply corresponds to the gauge transformation of the Hamiltonian

$$\hat{H}_{XXZ,general}^{(N)} = U H_{XXZ,general}^{(N)} U^{-1},$$

where

$$U \equiv \sigma^z \otimes 1 \otimes \sigma^z \otimes 1 \otimes \dots$$

The operator on the last tensor product space is σ^z for N odd and identity for N even.

4.3 Open Chain with Diagonal Boundary Matrices

This section will study the open XXZ Hamiltonian with diagonal boundary matrices using the algebraic Bethe ansatz. The previous section studied the integrable XXZ spin chain with non-diagonal boundary matrices. However, there is a special case which requires a more careful treatment. Let the boundary parameter β_{\pm} goes to the limit

$$\beta_{\pm} \rightarrow +\infty.$$

The functions $H_1(u)$ and $H_2(u)$ in the TQ equations will go to infinity due to the presence of the $\cosh(u \pm \beta_{\pm})$ term. Hence the construction of TQ equations in the last section does not exist. The Hamiltonian in this limit corresponds to the open XXZ chain Hamiltonian with diagonal boundary matrices, which is $H_{XXZ,Sklyanin}^{(N)}$ given by the relation (3.19). Historically, the transfer matrix in this limit has been studied before the transfer matrix with generic K -matrices.

The eigenvalue of $H_{XXZ,Sklyanin}^{(N)}$ is of the form

$$\begin{aligned} \Lambda(u) = & \frac{\sinh(2u + 2\eta) \sinh(u + \zeta_+) \sinh(u + \zeta_-)}{\sinh(2u + \eta)} \sinh(u + \eta)^{2N} \\ & \times \prod_{k=1}^M \frac{\sinh(u - v_m - \eta) \sinh(u + v_m)}{\sinh(u - v_m) \sinh(u + v_m + \eta)} \\ & + \frac{\sinh(2u) \sinh(u - \zeta_+ + \eta) \sinh(u - \zeta_- + \eta)}{\sinh(2u + \eta)} \sinh(u)^{2N} \\ & \times \prod_{k=1}^M \frac{\sinh(u - v_m + \eta) \sinh(u + v_m + 2\eta)}{\sinh(u - v_m) \sinh(u + v_m + \eta)}, \end{aligned} \quad (4.9)$$

where $\{v_1, \dots, v_M\}$ are Bethe roots satisfying the Bethe equations

$$\begin{aligned} & \frac{\sinh(v_m + \zeta_+) \sinh(v_m + \zeta_-) \sinh(v_m + \eta)^{2N}}{\sinh(v_m - \zeta_+ + \eta) \sinh(v_m - \zeta_- + \eta) \sinh(v_m)^{2N}} \\ &= \prod_{k=1, k \neq m}^M \frac{\sinh(v_m - v_k + \eta) \sinh(v_m + v_k + 2\eta)}{\sinh(v_m - v_k - \eta) \sinh(v_m + v_k)}, \quad 1 \leq m \leq M. \end{aligned}$$

Using the Bethe equations, it is easy to check that, for $\eta = 2i\pi/3$, the following system of equations is also true

$$\begin{aligned} & \frac{\sinh(v_m + \zeta_+) \sinh(v_m + \zeta_-) \sinh(v_m + \eta)^{2(N-1)}}{\sinh(v_m - \zeta_+ + \eta) \sinh(v_m - \zeta_- + \eta) \sinh(v_m)^{2(N-1)}} \\ &= \prod_{k=1, k \neq m}^M \frac{\sinh(v_m - v_k + \eta) \sinh(v_m + v_k + 2\eta)}{\sinh(v_m - v_k - \eta) \sinh(v_m + v_k)} \frac{\sinh(v_m - \eta + \eta) \sinh(v_m + \eta + 2\eta)}{\sinh(v_m - \eta - \eta) \sinh(v_m + \eta)}, \end{aligned}$$

for $1 \leq m \leq M$, and

$$\begin{aligned} & \frac{\sinh(\eta + \zeta_+) \sinh(\eta + \zeta_-) \sinh(\eta + \eta)^{2(N-1)}}{\sinh(\eta - \zeta_+ + \eta) \sinh(\eta - \zeta_- + \eta) \sinh(\eta)^{2(N-1)}} \\ &= \prod_{k=1}^M \frac{\sinh(\eta - v_k + \eta) \sinh(\eta + v_k + 2\eta)}{\sinh(\eta - v_k - \eta) \sinh(\eta + v_k)} \frac{\sinh(\eta - \eta + \eta) \sinh(\eta + \eta + 2\eta)}{\sinh(\eta - \eta - \eta) \sinh(\eta + \eta)}. \end{aligned}$$

However, the above equations are the Bethe equations of the length $N - 1$ Hamiltonian with Bethe roots $\{v_1, \dots, v_M, \eta\}$. In order to calculate the eigenvalue of the Hamiltonian, it is worth noting that the eigenvalue of the transfer matrix in relation (4.9) can be expressed in the form of relation (4.4). Let $Q(u)$ be defined as in relation (3.25), then

$$\Lambda(u) = H_1(u) \frac{Q(u + \eta)}{Q(u)} + H_2(u) \frac{Q(u - \eta)}{Q(u)},$$

where

$$H_1(u) = \frac{\sinh(2u) \sinh(u - \zeta_+ + \eta) \sinh(u - \zeta_- + \eta)}{\sinh(2u + \eta)} \sinh(u)^{2N},$$

and

$$H_2(u) = \frac{\sinh(2u + 2\eta) \sinh(u + \zeta_+) \sinh(u + \zeta_-)}{\sinh(2u + \eta)} \sinh(u + \eta)^{2N}.$$

Since $\frac{\partial H_1(u)}{\partial u} \Big|_{u=0} = H_1(u) \Big|_{u=0} = 0$, it follows from the same argument as in relation

(4.8) that

$$\begin{aligned} E &= \Lambda'(0) = c_1 \sum_{i=1}^M \frac{2 \sinh \eta}{\sinh v_m \sinh(v_m + \eta)} + c_2, \\ &= H_2(0) \sum_{i=1}^M \frac{2 \sinh(\eta)}{\sinh(v_i) \sinh(v_i + \eta)} + \frac{\partial}{\partial u} (H_2(u))|_{u=0}, \end{aligned}$$

where

$$\begin{aligned} c_1 &= H_2(0) = -\sinh \zeta_+ \sinh \zeta_- \sinh^{2N} \eta, \\ c_2 &= \frac{\partial}{\partial u} (H_2(u))|_{u=0} = -2N \sinh^{2N-1} \eta \cosh \eta \sinh \zeta_+ \sinh \zeta_- \\ &\quad - \sinh^{2N} \eta \sinh(\zeta_+ + \zeta_-) + \sinh^{2N-1} \eta \sinh \zeta_+ \sinh \zeta_- (2 \cosh(\eta) + 2 \cosh(2\eta)). \end{aligned}$$

The Hamiltonian can be normalised as

$$H_{XXZ,Sklyanin}^{(N)'} = \frac{H_{XXZ,Sklyanin}^{(N)}}{c_1} - \frac{c_2}{c_1} + N \frac{2}{\sinh(2\eta)} \mathbb{I}.$$

From relation (3.19), the Hamiltonian can be expressed using Pauli matrices as

$$\begin{aligned} H_{XXZ,Sklyanin}^{(N)'} &= \frac{1}{\sinh \eta} \left(\sum_{j=1}^{N-1} (\sigma_j^x \sigma_{j+1}^x + \sigma_j^y \sigma_{j+1}^y + \cosh(\eta) \sigma_j^z \sigma_{j+1}^z) \right. \\ &\quad \left. + \sinh(\eta) (\sigma_1^z \coth \zeta_- + \sigma_N^z \coth \zeta_+) \right) - \frac{3N-7}{2 \sinh(\eta)} \mathbb{I} + (\coth(\zeta_+) + \coth(\zeta_-)) \mathbb{I}, \end{aligned} \quad (4.10)$$

where $\eta = \frac{2i\pi}{3}$. It is easy to check that the eigenvalue of the normalised Hamiltonian of size N with $\{v_1, \dots, v_M\}$ and the eigenvalue of the normalised Hamiltonian of size $N-1$ with $\{v_1, \dots, v_M, \eta\}$ are equal

$$E'_{\{v_1, \dots, v_M\}} = E'_{\{v_1, \dots, v_M, \eta\}}.$$

Remark. *The same result can be shown using the coordinate Bethe ansatz [53].*

4.4 The Map S^{Bethe} and The Lattice Supercharge

This section will study the relation between S^{Bethe} and the lattice supercharge. A new Hamiltonian $H_{XXZ,diagonal}^{(N)}$ will be defined, where both the lattice supercharge and the map S^{Bethe} can be defined. The relation between these two operators is

$$S_N \propto S_N^{Bethe}.$$

This relation can be confirmed numerically, and it motivated the theorem in the next chapter where this relation will be proved analytically.

The Hamiltonian $H_{XXZ,diagonal}^{(N)}$ will be defined as

$$H_{XXZ,diagonal}^{(N)} = \frac{\sinh(\eta)}{-2} H_{XXZ,Sklyanin}^{(N)'} + 2\mathbb{I},$$

where parameters in $H_{XXZ,Sklyanin}^{(N)'}$ are fixed to be $\eta = 2i\pi/3$ and $\zeta_{\pm} = -\eta$. Using relation (4.10), this Hamiltonian can be written out using Pauli matrices as

$$H_{XXZ,diagonal}^{(N)} = -\frac{1}{2} \sum_{i=1}^{N-1} (\sigma_i^x \otimes \sigma_{i+1}^x + \sigma_i^y \otimes \sigma_{i+1}^y - \frac{1}{2} \sigma_i^z \otimes \sigma_{i+1}^z) - \frac{1}{4} \sigma_1^z - \frac{1}{4} \sigma_N^z + \frac{3N-1}{4} \mathbb{I}. \quad (4.11)$$

The Hamiltonian $H_{XXZ,diagonal}^{(N)}$ is a special case of $H_{XXZ,Hagen}^{(N)}$ defined in Section 2.2 and $H_{XXZ,SUSY}^{(N)}$ defined in Section 2.3. By direct calculation, $H_{XXZ,diagonal}^{(N)}$ is equal to $H_{XXZ,SUSY}^{(N)}$ in relation (2.6) with $r_{12} = 1$ and all the other variables to be zero. It follows that $H_{XXZ,diagonal}^{(N)}$ is equal to the anti-commutator of this lattice supercharge

$$H_{XXZ,diagonal}^{(N)} = S_{N+1} S_{N+1}^{\dagger} + S_N^{\dagger} S_N,$$

where the lattice supercharge S_N is constructed from the local supercharge as in

relation (2.4). The local supercharge p is

$$p = \begin{bmatrix} 0 & 0 & 0 & 0 \\ 1 & 0 & 0 & 0 \end{bmatrix}.$$

By the discussion of lattice SUSY in Section 2.1, it follows that $H_{XXZ,diagonal}^{(N)}$ has lattice SUSY with the lattice supercharge S_N .

The relation $S_N \propto S_N^{Bethe}$ is motivated by the action of S_N and S_N^{Bethe} on the eigenvectors. Section 4.3 has shown that there is a symmetry in the spectrum of $H_{XXZ,Sklyanin}^{(N)'}$ which induces the map S^{Bethe} . The map S^{Bethe} take an eigenstate of $H_{XXZ,Sklyanin}^{(N)'}$ to an eigenstate of $H_{XXZ,Sklyanin}^{(N-1)'}$ with the same eigenvalue. Since $H_{XXZ,diagonal}^{(N)}$ is a special case of $H_{XXZ,Sklyanin}^{(N)'}$ with a certain normalisation, the map S^{Bethe} also exists for $H_{XXZ,diagonal}^{(N)}$. Since the normalisation does not involve any function with the parameter N , S^{Bethe} will also take an eigenstate of $H_{XXZ,diagonal}^{(N)}$ to an eigenstate of $H_{XXZ,diagonal}^{(N-1)}$ with the same eigenvalue.

On the other hand, $H_{XXZ,diagonal}^{(N)}$ is supersymmetric with the lattice supercharge S_N . By the discussion about the supersymmetric Hamiltonian in Chapter 2, S_N will take an eigenstate of $H_{XXZ,diagonal}^{(N)}$ to an eigenstate of $H_{XXZ,diagonal}^{(N-1)}$ with the same eigenvalue. When the spectrum of the Hamiltonian $H_{XXZ,diagonal}^{(N)}$ is non-degenerate, the relation $S_N \propto S_N^{Bethe}$ must be true. For $H_{XXZ,diagonal}^{(N)}$, the spectrum is degenerate since η is a root of unity. However, numerical checks in Subsection 4.4.1 and Subsection 4.4.2 show that $S_N \propto S_N^{Bethe}$ is still true.

4.4.1 McCoy's Method

In order to look deeper into the structure of the spectrum of the spin chain Hamiltonian, and to understand the action of S_N on the eigenstates generated by Bethe roots, Bethe roots need to be calculated. Since it is a difficult task to solve Bethe equations numerically using the 'solve' function in Maple software, the method developed by B.McCoy [95] will be used. This method is based on the TQ equations.

When the TQ equations exist for the transfer matrix, any eigenvalue can be written as

$$\Lambda(u) = h_1(u) \frac{Q(u - \eta)}{Q(u)} + h_2(u) \frac{Q(u + \eta)}{Q(u)},$$

where h_1 and h_2 are scalar functions, and $Q(u)$ is defined in relation (3.25). The following steps will be used to compute the values of Bethe roots:

- First, the parameter u of the transfer matrix will be fixed to any chosen value. The eigenstates and eigenvectors of this constant matrix will be computed numerically. Since integrable transfer matrices with different parameters share the same eigenvectors, the action of the transfer matrix on the eigenstates of the constant transfer matrix will give a numerical approximation of the eigenvalues, which are functions of the parameter u .
- The TQ equations will be rewritten as

$$\Lambda(u)Q(u) - h_1(u)Q(u - \eta) - h_2(u)Q(u + \eta) = 0,$$

where the eigenvalue $\Lambda(u)$ is obtained numerically from the first step. The variable u will be rewritten as $x = e^u$. Hence the left hand side of the above relation becomes a polynomial of x , where coefficients involve Bethe roots. Since all coefficients need to be zero, this implies that Bethe roots satisfy a system of equations.

- The final step will simplify the equations obtained in the step two. A simple example will show that the system of equations is nonlinear. In order to linearise the equations, $Q(x)$ will be redefined as

$$Q(x) = \sum_{k=0}^M b_k (x^{2k} + (xq)^{-2k}),$$

where $q = e^\eta$ and $\{b_k\}_{k=0,\dots,M}$. Following the second step and using the new expression for $Q(x)$, a system of linear equations will be obtained. Solving this linear system will give a solution of $Q(x)$ as a polynomial up to a scalar,

and roots of this polynomial are Bethe roots.

4.4.2 Direct Diagonalisation

This subsection will give some numerical results on the spectrum of the transfer matrix, which are obtained from McCoy's method. The expression of eigenvalue of this transfer matrix has been given in Theorem 5. The function needed in the TQ equations are given as

$$h_1(u) = h_2(-u - \eta) = \frac{\sinh(2u + 2\eta)}{\sinh(2u + \eta)} \sinh(u + \zeta_+) \sinh(u + \zeta_-) \delta_+(u) \delta_-(-u - \eta),$$

and

$$Q(u) = \prod_{k=1, k \neq m}^M \sinh(u - v_m) \sinh(u + v_m + \eta).$$

The eigenvalues $\Lambda(u)$ of the transfer matrix at $u = i$ of the length $N = 3$, $N = 4$ and $N = 5$ are given in the three tables in the end of this section.

Since the Bethe equations have been solved, eigenstates can be obtain from the expression

$$\mathcal{B}(v_1) \dots \mathcal{B}(v_M) \Omega_N,$$

where $\{v_1, \dots, v_M\}$ are Bethe roots. The numerical checks have shown that the lattice supercharge S_N take an eigenstate $\mathcal{B}(v_1) \dots \mathcal{B}(v_M) \Omega_N$ to another eigenstate $\mathcal{B}(v_1) \dots \mathcal{B}(v_M) \mathcal{B}(\eta) \Omega_{N-1}$ when $v_i \neq \eta$ for all $i = 1, \dots, N$. When $v_i = \eta$ for all certain $i \in 1, \dots, N$, the action of S_N on $\mathcal{B}(v_1) \dots \mathcal{B}(v_M) \Omega_N$ is zero. In the table with $N = 5$, the lattice supercharge S_5 has been used to act on any eigenstate generated by the set of Bethe roots excluding $\eta \approx 2.094395102393195492I$. The results are eigenstates with the same set of Bethe roots plus an additional Bethe root η in the table of $N = 4$. For example, S_5 takes the eigenstate of the transfer matrix at $N = 5$ with Bethe roots $\{0.189840656161305677 - 2.617993877991494365I\}$ to the eigenstate of the transfer matrix at $N = 4$ with $\{0.189840656161305677 - 2.617993877991494365I, 2.094395102393195492I\}$. Similarly in the table with $N =$

4, any eigenstate which does not include η will be mapped by S_4 to an eigenstate in the table of $N = 3$ with the same Bethe roots plus an additional Bethe root η . The action of S_N on eigenstates generated by the set of Bethe roots including η are zero. There are three special cases, i.e. $\Lambda(i) = -0.388910734232823548$ in $N = 3$, $\Lambda(i) = 0.307123050467152908$ in $N = 4$ and $\Lambda(i) = -0.242535265359329041$ in $N = 5$, which are mapped to zero by S_N . Those sets corresponds to the supersymmetric singlet.

$\Lambda(i), N = 3$	Bethe roots
-0.388910734232823548	$\{0.346573590279972654 - 2.617993877991494365I\}$
-0.364922327712076772	$\{0.243868443159090244 - 2.617993877991494365I, 2.094395102393195492I\}$
-0.312768559192756345	None
-0.312667245940495167	$\{0.658478948462408354 - 2.617993877991494365I, 2.094395102393195492I\}$
-0.280439316016709334	$\{2.094395102393195492I\}$
-0.268067956627562349	$\{0.902347391621498599 + 2.094395102393195492I, 2.094395102393195492I\}$

$\Lambda(i), N = 4$	Bethe roots
0.185637927710851181	$\{0.6368887597197771483 + 2.094395102393195492I, 2.094395102393195492I\}$
0.198571625112257655	$\{2.094395102393195492I\}$
0.206996948893242215	$\{1.0839368632782486188 - 2.617993877991494365I, 2.094395102393195492I\}$
0.211693433287100201	$\{0.902347391621498599 + 2.094395102393195492I\}$
0.221463103547077305	None
0.236815835684886928	$\{0.4470481035584714704 - 2.617993877991494365I, 2.094395102393195492I\}$
0.246913519997936405	$\{0.658478948462408354 - 2.617993877991494365I\}$
0.264254619023349945	$\{0.1898406561613056779 - 2.617993877991494365I, 2.094395102393195492I\}$
0.288179390809542733	$\{0.243868443159090244 - 2.617993877991494365I\}$
0.307123050467152908	$\{-0.8570731112297207845 - 2.617993877991494365I, 0.256013229625077919 - 2.617993877991494365I\}$

$\Lambda(i), N = 5$	Bethe roots
-0.242535265359329041	$\{-0.504773412134716060 + 0.523598775598298873I,$ $0.201117460722222413 - 2.617993877991494365I\}$
-0.231926506616731954	$\{0.376118392450686110 - 2.617993877991494365I,$ $0.164317710486570667 - 2.617993877991494365I,$ $2.094395102393195492I\}$
-0.208682038192086715	$\{0.189840656161305677 - 2.617993877991494365I\}$
-0.205561308514509576	$\{0.160969969798059705 - 2.617993877991494365I,$ $0.774681037571526365 - 2.617993877991494365I,$ $2.094395102393195492I\}$
-0.189479581370620001	$\{0.155952679091217849 - 2.617993877991494365I,$ $2.094395102393195492I\}$
-0.189024489033665780	$\{0.765050734850749381 - 2.617993877991494365I,$ $0.362750128054243882 - 2.617993877991494365I,$ $2.094395102393195492I\}$
-0.187013613799945530	$\{0.447048103558471470 - 2.617993877991494365I\}$
-0.182633376423723889	$\{0.151628797750494857 - 2.617993877991494365I,$ $1.000543726900273134 + 2.094395102393195492I,$ $2.094395102393195492I\}$
-0.174832562908192230	$\{0.346573590279972654 - 2.617993877991494365I,$ $2.094395102393195492I\}$
-0.163465620219747533	$\{1.083936863278248618 - 2.617993877991494365I\}$
-0.156812136751635447	None
-0.156761341030459612	$\{0.658478948462408354 - 2.617993877991494365I,$ $2.094395102393195492I\}$
-0.152400313461410151	$\{0.583385627093906993 - 2.617993877991494365I,$ $0.853781969633961425 + 2.094395102393195492I,$ $2.094395102393195492I\}$
-0.149257479786784030	$\{0.706816288260926223 + 3.138511930947246476I,$ $0.706816288260926223 - 2.091314379750648730I,$ $2.094395102393195492I\}$
-0.146598387811085394	$\{0.636888759719777148 + 2.094395102393195492I\}$
-0.140603289365378849	$\{2.094395102393195492I\}$
-0.138007251885736477	$\{0.977904727002991095 - 2.617993877991494365I,$ $0.595371976110936743 - 1.047197551196597746I,$ $2.094395102393195492I\}$
-0.129818811124521185	$\{0.502526269371190504 + 2.094395102393195492I,$ $2.094395102393195492I\}$
-0.126229581873973952	$\{1.230808758725261201 + 2.094395102393195492I,$ $-0.474919634569165021 - 1.047197551196597746I,$ $2.094395102393195492I\}$

Chapter 5

Integrability and Lattice Supersymmetry

This chapter will study the spin half open XXZ Hamiltonian

$$H_{XXZ,diagonal}^{(N)} = -\frac{1}{2} \sum_{i=1}^{N-1} (\sigma_i^x \otimes \sigma_{i+1}^x + \sigma_i^y \otimes \sigma_{i+1}^y - \frac{1}{2} \sigma_i^z \otimes \sigma_{i+1}^z) - \frac{1}{4} \sigma_1^z - \frac{1}{4} \sigma_N^z + \frac{3N-1}{4} \mathbb{I}.$$

This Hamiltonian is first defined in Section 4.4. Section 4.4 has shown that $H_{XXZ,diagonal}^{(N)}$ is related to an integrable transfer matrix, and its spectrum can be solved by the algebraic Bethe ansatz. Section 4.4 has also shown that $H_{XXZ,diagonal}^{(N)}$ has lattice supersymmetry, and has given the construction of the lattice supercharge S_N . Section 5.1 will define the diagrams associated with some of the operators, e.g. the local supercharge p , the lattice supercharge S_N . In Section 5.2, S_N will be incorporated into the construction of the algebraic Bethe ansatz through a commutation relation between S_N and the creation operator \mathcal{B} in the algebraic Bethe ansatz. This commutation relation will be proved together with other commutation relations between S_N and the operators \mathcal{A} , \mathcal{C} and \mathcal{D} in the algebraic Bethe ansatz. The diagrams defined in Section 5.1 and Chapter 3 will be used in the proof of the main theorem in Section 5.2. Section 5.3 will study the supersymmetric Hamiltonian with anti-diagonal boundary matrices, and prove that there are similar commutation relations

between its lattice supercharge S_N and the operators \mathcal{A} , \mathcal{C} and \mathcal{D} corresponding to this Hamiltonian.

5.1 Lattice Supersymmetry

Let the local supercharge be

$$p = \begin{bmatrix} 0 & 0 & 0 & 0 \\ 1 & 0 & 0 & 0 \end{bmatrix}.$$

The lattice supercharge S_N is defined in relation (2.4). By the discussion in Section 4.4, it follows that

$$H_{XXZ,diagonal}^{(N)} := S_{N+1}S_{N+1}^\dagger + S_N^\dagger S_N.$$

Some of the operators defined above have diagrammatical representations which will be useful later on. In the diagram of the vertex model, the space V is identified with a single line ($|$). The diagram of the identity map from V to itself is a vertical line with an arrow in the middle. The tensor product space $V \otimes V$ is two parallel lines ($||$). The diagram of p is chosen such that it connects two parallel lines to one line with an arrow pointing from two lines to the one line

$$p \sim \begin{array}{c} \diagdown \quad \diagup \\ \downarrow \\ \cdot \end{array}.$$

The component of this map can also be defined by diagrams. For example, the coefficients of map p from $(++)$ to $(-)$ is 1. The diagram for this coefficient is

$$\begin{array}{c} + \quad + \\ \diagdown \quad \diagup \\ \downarrow \\ - \\ \cdot \end{array}.$$

The other coefficients of p are zero. The diagram of S_N is the sum of diagrams of $(-1)^{i+1}p_i$ over i . The diagram of $(-1)^{i+1}p_i$ is

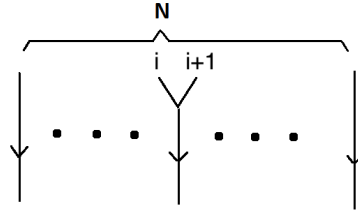

The bottom half of this diagram is $N - 1$ parallel lines with the diagram of p on the i th position. It is worth noting that the coefficients $(-1)^{i+1}$ is incorporated in the above diagram. This will simplify the diagrams appearing later in Section 5.2. The above definition of the diagram of $(-1)^{i+1}p_i$ is consistent with the diagram of p . In fact, p can be defined as $(-1)^{1+1}p_1$ with $N = 1$, and they have the same diagram. The diagram of lattice supercharge is the sum of diagrams $(-1)^{i+1}p_i$ over i . For example, when $N = 3$

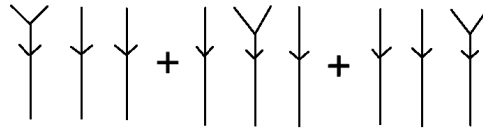

The above diagram will be simplified as

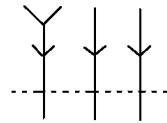

where the dashed line means taking the sum of $(-1)^{i+1}p_i$. Then the diagram for S_N is

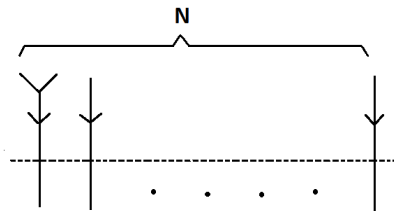

5.2 The Algebraic Bethe Ansatz and Lattice Supersymmetry

The main results in this chapter are the connections between two hitherto unrelated operators, namely, the lattice supercharge and the creation operator \mathcal{B} in the algebraic Bethe ansatz. Their relations is expressed in the following commutation relations

$$\mathcal{B}_{N-1}(u)S_N = d^2 S_N \mathcal{B}_N(u),$$

$$S_N \Omega_N = \hat{c} \mathcal{B}(\eta)_{N-1} \Omega_{N-1},$$

where $d = \sinh(u - \eta)$, $\hat{c} = 1/\sinh(\eta)^{2N-1}$ and Ω_N is the reference state in the algebraic Bethe ansatz. The above commutation relations are motivated by the following relation which has been confirmed numerically in Section 4.4

$$S_N \mathcal{B}_N(v_1) \dots \mathcal{B}_N(v_M) \Omega_N \propto \mathcal{B}_{N-1}(v_1) \dots \mathcal{B}_{N-1}(v_M) \mathcal{B}_{N-1}(\eta) \Omega_{N-1},$$

where $\{v_1, \dots, v_M\}$ and $\{v_1, \dots, v_M, \eta\}$ are the sets of Bethe roots of the transfer matrix of the length N and $N - 1$ respectively. This is a necessary condition of the two commutation relations in the beginning of this section.

The commutation relation $\mathcal{B}_{N-1}(u)S_N = d^2 S_N \mathcal{B}_N(u)$ will be proved in the following theorem. In the following theorem and the rest this section, the operators \mathcal{A}_N , \mathcal{B}_N , \mathcal{C}_N and \mathcal{D}_N and their diagrams will be defined as in Section 3.4, and the lattice supercharge S_N will be defined as in Section 5.1.

Theorem 6. *The following commutation relations are true*

$$S_N \mathcal{B}_N(u) - d^2 \mathcal{B}_{N-1}(u) S_N = 0, \quad (5.1)$$

$$S_N \mathcal{A}_N(u) - d^2 \mathcal{A}_{N-1}(u) S_N = \mathcal{B}_{N-1} \otimes (f(u, N) E^+), \quad (5.2)$$

$$S_N \mathcal{D}_N(u) - d^2 \mathcal{D}_{N-1}(u) S_N = \mathcal{B}_{N-1} \otimes (g(u, N) E^+), \quad (5.3)$$

$$\begin{aligned} S_N \mathcal{C}_N(u) - d^2 \mathcal{C}_{N-1}(u) S_N &= \mathcal{B}_{N-1} \otimes (h_1(u, N) E^-) \\ &+ \mathcal{A}_{N-1} \otimes (h_2(u, N) E^+) + \mathcal{D}_{N-1} \otimes (h_3(u, N) E^+), \end{aligned} \quad (5.4)$$

where the scalar functions are defined as

$$\left\{ \begin{array}{l} f(u, N) = (-1)^N cd \\ g(u, N) = (-1)^N bc \\ h_1(u, N) = (-1)^N c^2 \\ h_2(u, N) = (-1)^N ac \\ h_3(u, N) = (-1)^N cd \end{array} \right. ,$$

where a, b, c and d are given by $a = \sinh(u + \eta), b = \sinh(u), c = \sinh(\eta)$ and $d = \sinh(u - \eta)$.

Let η be fixed as $\frac{2i\pi}{3}$, it follows that

$$a + b + d = 0, \quad (5.5)$$

$$a^2 + b^2 - c^2 + ab = 0. \quad (5.6)$$

During the proof of theorems, relations (5.5) and (5.6) will be used to simplify the proof.

The following notations are also needed. Operators $E^{\epsilon_1} : V \rightarrow \mathbb{C}$, $E_{\epsilon_2}^{\epsilon_1} : V \rightarrow V$ and $E_{\epsilon_3}^{\epsilon_1 \epsilon_2} : V \otimes V \rightarrow V$, with $\epsilon_i \in \{+, -\}$ will be defined by

$$E^{\epsilon_1} v_{\epsilon_1'} = \delta_{\epsilon_1, \epsilon_1'}, E_{\epsilon_2}^{\epsilon_1} v_{\epsilon_1'} = \delta_{\epsilon_1, \epsilon_1'} v_{\epsilon_2}, E_{\epsilon_3}^{\epsilon_1 \epsilon_2} (v_{\epsilon_1'} \otimes v_{\epsilon_2'}) = \delta_{\epsilon_1, \epsilon_1'} \delta_{\epsilon_2, \epsilon_2'} v_{\epsilon_3}.$$

It is worth noting that $p = E_-^{++}$. It is easy to see

$$E^{\epsilon_1} \otimes E^{\epsilon_2} = E_{\epsilon_3}^{\epsilon_1 \epsilon_2} = E_{\epsilon_3}^{\epsilon_1} \otimes E^{\epsilon_2}.$$

Proof. The theorem will be proved using the mathematical induction on the size N .

The mathematical induction relies on the proof of the following:

- The induction hypothesis: The relations (5.1) – (5.4) is true for $N = 2$.
- The induction step: For any integer $k \geq 2$, if (5.1) – (5.4) is true for $N = k$, they are also true for $k + 1$.

Using diagrams, it is easy to check the induction hypothesis. The left hand side of relation (5.1) at $N = 2$ on $(+) \otimes (+)$ can be represented by the diagram

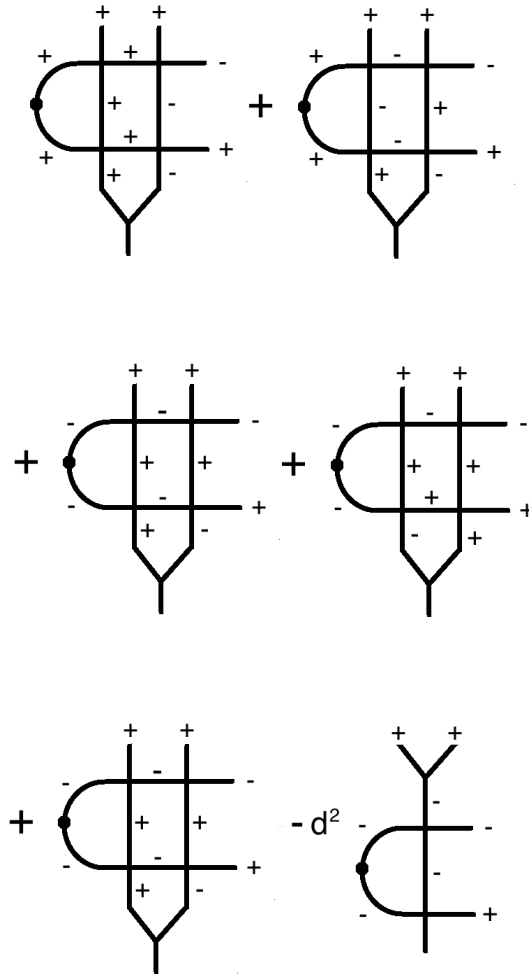

It is easy to see that all the terms in the above diagram are zero. Hence the left hand side of relation (5.1) at $N = 2$ is equal to the right hand side of relation (5.1) on $(+) \otimes (+)$, i.e. the relation (5.1) at $N = 2$ is true on $(+) \otimes (+)$. The relation (5.1) at $N = 2$ on $(-) \otimes (+)$, $(+) \otimes (-)$ and $(-) \otimes (-)$ can be confirmed using the same method. Hence the relation (5.1) at $N = 2$ is true. The relation (5.2), (5.3) and (5.4) at $N = 2$ can be proved using the same method too.

In order to prove the induction step, commutation relations at the length $k + 1$ will be written out using diagrams. From the diagrams, it is easy to see that commutation relations at the length $k + 1$ are implied from commutation relations at the length k . The proof of the theorem has four parts. Each part deals with one of the commutation relation at the length $k + 1$, and its proof will involve up to all four relations at the length k .

(I). The proof of the relation (5.1) will be carried out as the following: The left hand side of the relation (5.1) for the length $k + 1$ will be rewritten, such that S_{k+1} , $\mathcal{B}_{k+1}(u)$ and $\mathcal{B}_k(u)$ can be expressed by S_k and the operators \mathcal{A} , \mathcal{B} , \mathcal{C} , \mathcal{D} of the length k and $k - 1$. Then using the relations (5.1) – (5.4) for the length k , it is easy to show that all terms in the left hand side of the relation (5.1) for the length $k + 1$ cancel. Hence the left hand side is equal to the right hand side and the relation (5.1) is true.

The relation (5.1) will be rewritten with the help of diagrams. The diagram of the left hand side of the relation (5.1) for the length $k + 1$ is

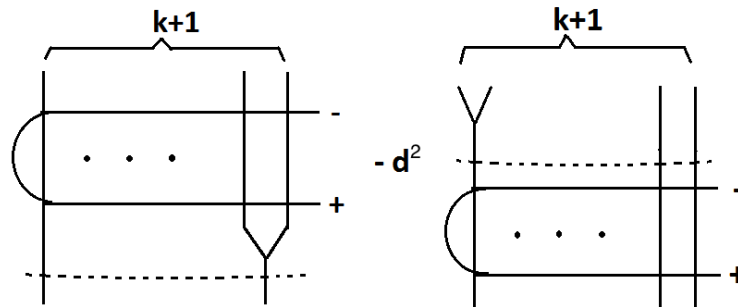

In order to examine the details of the above diagram, the input on the rightmost site will be restricted to $(-)$ first, and to $(+)$ later. This is equivalent to restricting the range of the operator $S_{k+1}\mathcal{B}_{k+1}(u) - d^2\mathcal{B}_k(u)S_{k+1}$ to the subspace $V^{\otimes k} \otimes (-)$ and $V^{\otimes k} \otimes (+)$. The relation $S_{k+1}\mathcal{B}_{k+1}(u) - d^2\mathcal{B}_k(u)S_{k+1} = 0$ will be proved on both of the subspaces of $V^{\otimes k+1}$. For $(-)$ on the rightmost site, the diagram becomes

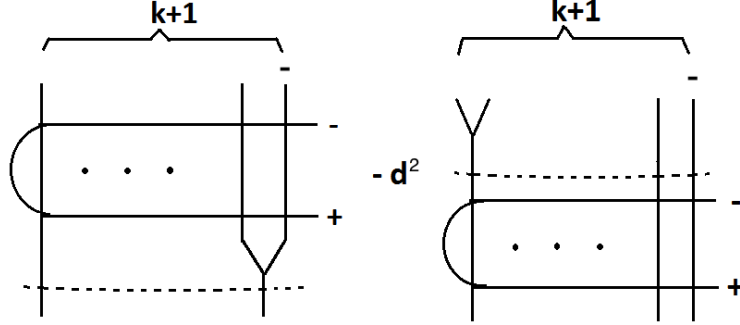

To further simplify this diagram, the following expression is used

$$S_{k+1} = \sum_{i=1}^{k+1} (-1)^{i+1} p_i = \sum_{i=1}^k (-1)^{i+1} p_i + (-1)^{k+2} p_{k+1}.$$

Hence the diagram for S_{k+1} becomes

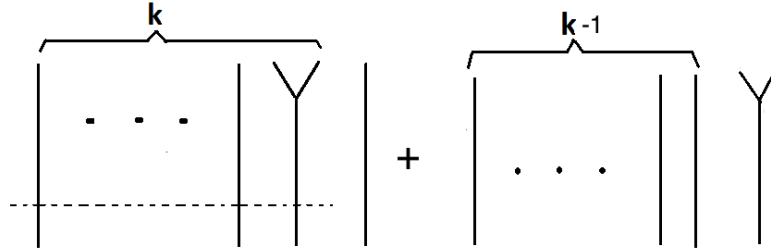

Using the above diagram, the diagram of $S_{k+1}\mathcal{B}_{k+1}(u) - d^2\mathcal{B}_k(u)S_{k+1}$ on $V^{\otimes k} \otimes (-)$ can be rewritten as

It is worth noting that the third and the fourth terms in the above diagram correspond to zeros, since the map p is only non-zero with the input $(++)$. The left hand side of the relation (5.1) on $V^{\otimes k} \otimes (-)$ is

$$(S_k \mathcal{B}_k(u) - d^2 \mathcal{B}_{k-1}(u) S_k) \otimes (abE^-).$$

By using the relation (5.1) for the length k , it follows that the above expression is zero. Hence $S_{k+1} \mathcal{B}_{k+1}(u) - d^2 \mathcal{B}_k(u) S_{k+1}$ is zero on $V^{\otimes k} \otimes (-)$.

Using similar argument, the diagram of $S_{k+1} \mathcal{B}_{k+1}(u) - d^2 \mathcal{B}_k(u) S_{k+1}$ on $V^{\otimes k} \otimes (+)$ can be written as

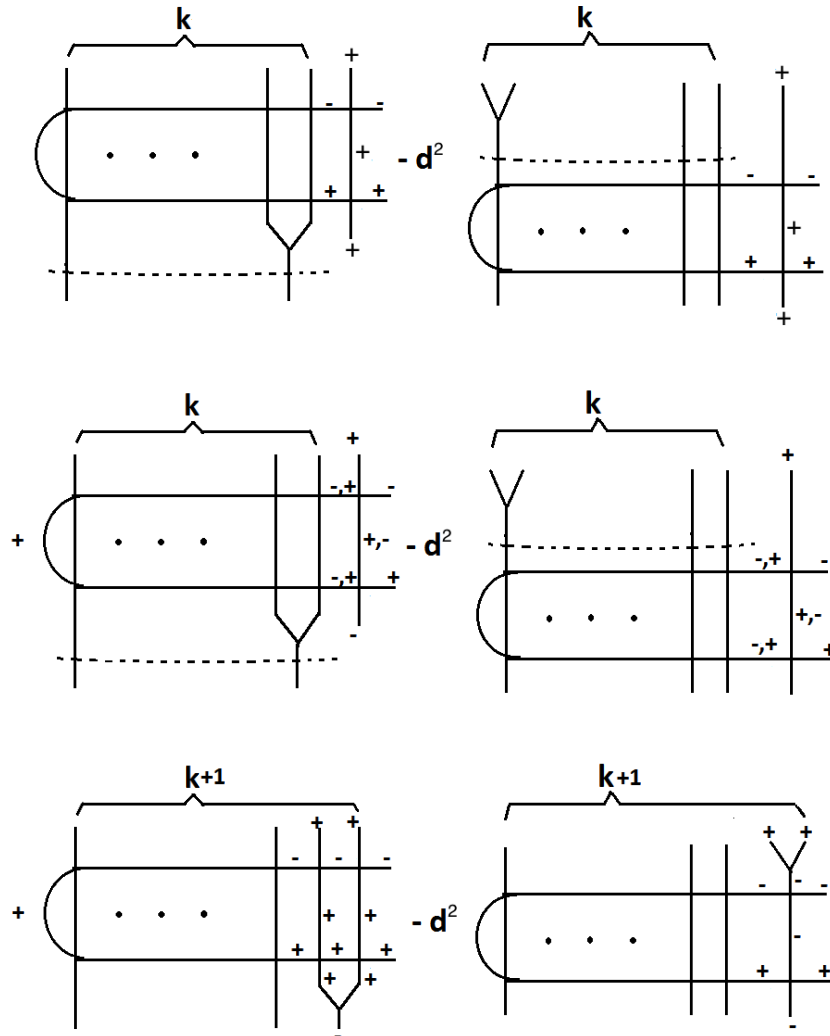

From the relation (5.1) at the length k , it follows that the first two terms cancel. Using the relations (5.2) and (5.3), it follows that the third and the fourth terms

become

$$\mathcal{B}_{k-1} \otimes E^+ \otimes E_-^+(bc(f(u, k) + g(u, k))).$$

Using $E^+ \otimes E_-^+ = E_-^{++}$, the above expression becomes

$$\mathcal{B}_{k-1} \otimes E_-^{++}(bc(f(u, k) + g(u, k))).$$

The fifth and the sixth terms are

$$\mathcal{B}_{k-1} \otimes E_-^{++}((-1)^k(a^2b^2 - d^2ab)).$$

Overall, the righthand side of the relation (5.1) on $V^{\otimes k} \otimes (+)$ is

$$\mathcal{B}_{k-1} \otimes E_-^{++}((-1)^k(a^2b^2 - d^2ab) + bc(f(u, k) + g(u, k))).$$

Using the relations (5.5) and (5.6), it can be shown that

$$\begin{aligned} & (-1)^{k+1}(a^2b^2 - abd^2) + bc(f(u, k) + g(u, k)) \\ &= (-1)^{k+1}(a^2b^2 - abd^2 - b^2c^2 - bc^2d), \\ &= (-1)^{k+1}(a^2b^2 - a^3b - ab^3 - 2a^2b^2 - b^2c^2 + b^2c^2 + abc^2), \\ &= (-1)^{k+1}ab(-a^2 - b^2 - ab + c^2) = 0. \end{aligned}$$

Hence $S_{k+1}\mathcal{B}_{k+1}(u) - d^2\mathcal{B}_k(u)S_{k+1}$ is zero on $V^{\otimes k} \otimes (+)$. Hence the relation (5.1) is true for the length $k + 1$.

(II). The relation (5.2) will be first proved on $V^{\otimes k} \otimes (-)$, then proved on $V^{\otimes k} \otimes (+)$. The right hand side of the relation (5.2) is zero on $V^{\otimes k} \otimes (-)$. In order to show the relation (5.2) is true on $V^{\otimes k} \otimes (-)$, it is sufficient to prove that the left hand side of the relation (5.2) is zero. The left hand side of the relation (5.2) for the length $k + 1$ can be written out in diagrams as

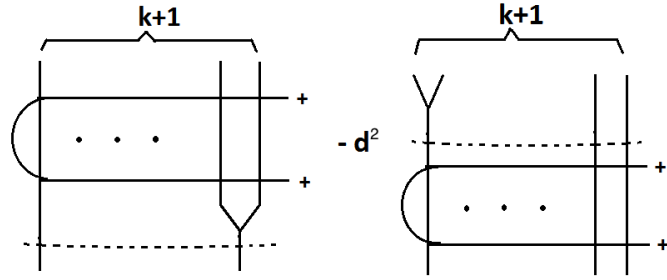

For $V^{\otimes k} \otimes (-)$, the left hand side of the relation (5.2) becomes

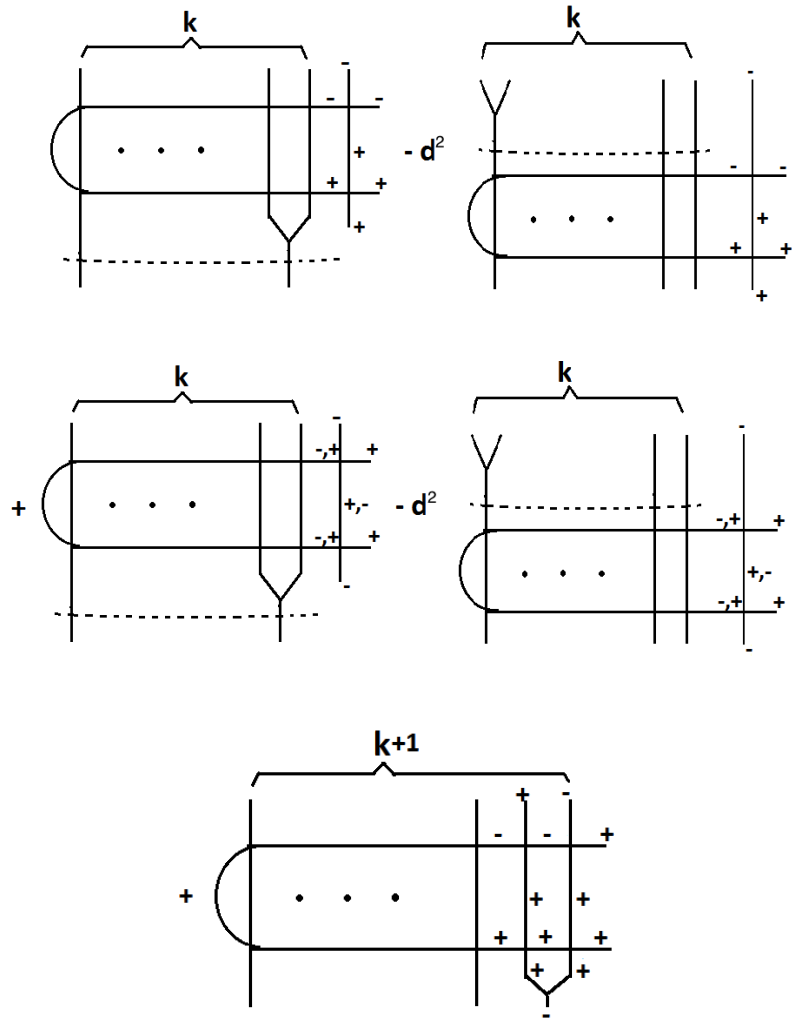

Using the relation (5.1) at the length k , it follows that the first two terms cancel. Using relations (5.2) and (5.3) with the same argument as in the part (I), it follows that the third to the last terms become

$$\mathcal{B}_{k-1} \otimes E_-^{+-} (b^2 f(u, k) + c^2 g(u, k) + (-1)^{k+1} (a^2 bc)).$$

Using relations (5.5) and (5.6), it follows that

$$\begin{aligned}
 & b^2 f(u, k) + c^2 g(u, k) + (-1)^{k+1} (a^2 bc) \\
 &= (-1)^k (b^2 cd + bc^3) + (-1)^{k+1} (a^2 bc), \\
 &= (-1)^k (-ab^2 c - b^3 c + bc^3 - a^2 bc), \\
 &= (-1)^k bc (-ab - b^2 + c^2 - a^2) = 0.
 \end{aligned}$$

Hence the relation (5.2) on $V^{\otimes k} \otimes (-)$ is true.

The next statement to prove is the relation (5.2) on $V^{\otimes k} \otimes (+)$. This will be proved by showing the left hand side and the right hand side of the relation (5.2) are equal on $V^{\otimes k} \otimes (+)$. The left hand side of the relation (5.2) acting on $V^{\otimes k} \otimes (+)$ corresponds to the diagram

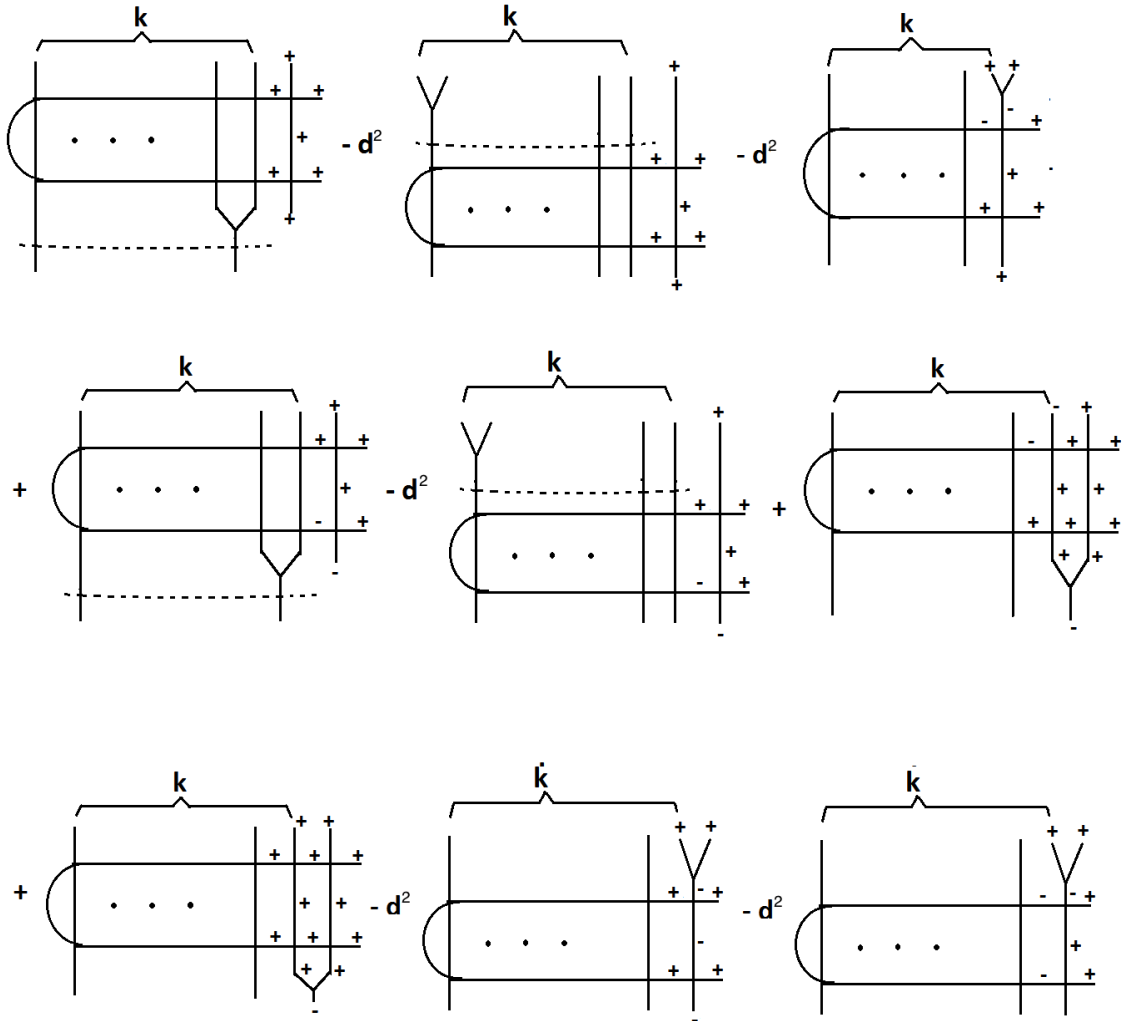

Using the relation (5.2), the first two terms become

$$\mathcal{B}_{k-1} \otimes E_+^{++}(f(u, k)a^2).$$

Hence the first three terms are

$$\mathcal{B}_{k-1} \otimes E_+^{++}(f(u, k)a^2 - (-1)^{k+1}d^2ac).$$

Similarly, using the relation (5.4), the fourth and fifth terms become

$$\begin{aligned} &\mathcal{B}_{k-1} \otimes E_-^{-+}(h_1(u, k)ac) + \mathcal{A}_{k-1} \otimes E_-^{++}(h_2(u, k)ac) \\ &+ \mathcal{D}_{k-1} \otimes E_-^{++}(h_3(u, k)ac). \end{aligned}$$

The sixth to the last terms are

$$\begin{aligned} &\mathcal{B}_{k-1} \otimes E_-^{-+}((-1)^{k+1}a^3c) + \mathcal{A}_{k-1} \otimes E_-^{++}((-1)^{k+1}(a^4 - d^2b^2)) \\ &+ \mathcal{D}_{k-1} \otimes E_-^{++}((-1)^{k+1}(-d^2)c^2). \end{aligned}$$

Hence the left hand side of the relation (5.2) can be written as

$$\begin{aligned} &\mathcal{B}_{k-1} \otimes E_+^{++}(f(u, k)a^2 - (-1)^{k+1}d^2ac) \\ &+ \mathcal{B}_{k-1} \otimes E_-^{-+}(h_1(u, k)ac + (-1)^{k+1}a^3c) \\ &+ \mathcal{A}_{k-1} \otimes E_-^{++}(h_2(u, k)ac + (-1)^{k+1}(a^4 - d^2b^2)) \\ &+ \mathcal{D}_{k-1} \otimes E_-^{++}(h_3(u, k)ac - (-1)^{k+1}d^2c^2). \end{aligned} \tag{5.7}$$

The right hand side of the relation (5.2) is $\mathcal{B}_k \otimes (f(u, k+1)E^+)$. Recall the diagram of \mathcal{B}_k

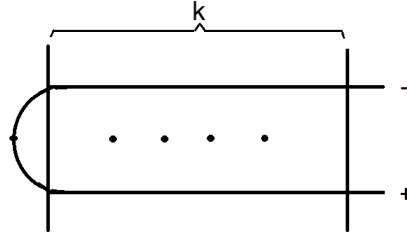

It can be rewritten as

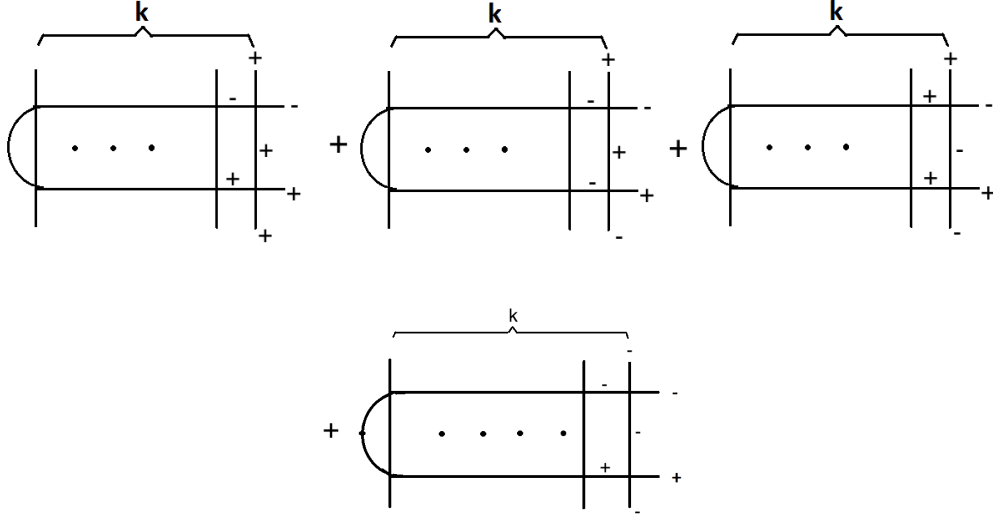

This is the relation

$$\mathcal{B}_k = \mathcal{B}_{k-1} \otimes E_+^+ ab + \mathcal{B}_{k-1} \otimes E_-^- ab + \mathcal{A}_{k-1} \otimes E_-^+ bc + \mathcal{D}_{k-1} \otimes E_-^+ bc. \quad (5.8)$$

Hence $\mathcal{B}_k \otimes (f(u, k+1)E^+)$ becomes

$$\begin{aligned} & \mathcal{B}_{k-1} \otimes E_+^{++}(f(u, k+1)ab) + \mathcal{B}_{k-1} \otimes E_-^{-+}(f(u, k+1)ab) \\ & + \mathcal{A}_{k-1} \otimes E_-^{++}(f(u, k+1)bc) + \mathcal{D}_{k-1} \otimes E_-^{++}(f(u, k+1)bc). \end{aligned} \quad (5.9)$$

The difference of relations (5.7) and (5.9) is

$$\begin{aligned} & \mathcal{B}_{k-1} \otimes E_+^{++}(f(u, k+1)ab - f(u, k)a^2 + (-1)^{k+1}d^2ac) \\ & + \mathcal{B}_{k-1} \otimes E_-^{-+}(f(u, k+1)ab - h_1(u, k)ac - (-1)^{k+1}a^3c) \\ & + \mathcal{A}_{k-1} \otimes E_-^{++}(f(u, k+1)bc - h_2(u, k)ac - (-1)^{k+1}(a^4 - d^2b^2)) \\ & + \mathcal{D}_{k-1} \otimes E_-^{++}(f(u, k+1)bc - h_3(u, k)ac + (-1)^{k+1}d^2c^2). \end{aligned}$$

Using relations (5.5) and (5.6), it follows that

$$\begin{aligned} f(u, k+1)ab - f(u, k)a^2 + (-1)^{k+1}d^2ac &= (-1)^{k+1}cdab - (-1)^k cda^2 + (-1)^{k+1}d^2ac, \\ &= (-1)^{k+1}(-a^2bc - ab^2c - a^3c - a^2bc + a^3c + ab^2c + 2a^2bc) = 0, \end{aligned}$$

and

$$\begin{aligned} f(u, k+1)ab - h_1(u, k)ac - (-1)^{k+1}a^3c &= (-1)^{k+1}cdab - (-1)^k c^2ac - (-1)^{k+1}a^3c, \\ &= (-1)^{k+1}(-a^2bc - ab^2c + ac^3 - a^3c) = (-1)^{k+1}ac(-ab - b^2 + c^2 - a^2) = 0, \end{aligned}$$

and

$$\begin{aligned} f(u, k+1)bc - h_2(u, k)ac - (-1)^{k+1}(a^4 - d^2b^2) &= (-1)^{k+1}cdbc - (-1)^k acac - (-1)^{k+1}(a^4 - d^2b^2), \\ &= (-1)^{k+1}(-abc^2 - b^2c^2 + a^2c^2 - a^4 + a^2b^2 + b^4 + 2ab^3), \\ &= (-1)^{k+1}(-a^3b - ab^3 - a^2b^2 - a^2b^2 - b^4 - ab^3 + a^4 + a^2b^2 + a^3b - a^4 + a^2b^2 + b^4 + 2ab^3) = 0, \end{aligned}$$

and

$$\begin{aligned} f(u, k+1)bc - h_3(u, k)ac + (-1)^{k+1}d^2c^2 &= (-1)^{k+1}cdbc - (-1)^k cdac + (-1)^{k+1}d^2c^2, \\ &= (-1)^{k+1}(-abc^2 - b^2c^2 - a^2c^2 - abc^2 + a^2c^2 + b^2c^2 + 2abc^2) = 0. \end{aligned}$$

These above relations have proved that the expression (5.7) is equal to (5.9). Hence the left hand side and the right hand side of the relation (5.2) is equal on $V^k \otimes (+)$. Hence the relation (5.2) is true.

(III). The relation (5.3) will be proved first on $V^{\otimes k} \otimes (-)$, and then on $V^{\otimes k} \otimes (+)$. The right hand side of the relation (5.3) is zero on $V^{\otimes k} \otimes (-)$. In order to show the relation (5.3) is true on $V^{\otimes k} \otimes (-)$, it is sufficient to prove that the left hand side of the relation (5.3) is zero. The left hand side of commutation relation (5.3) for $k+1$ can be written out in diagrams as

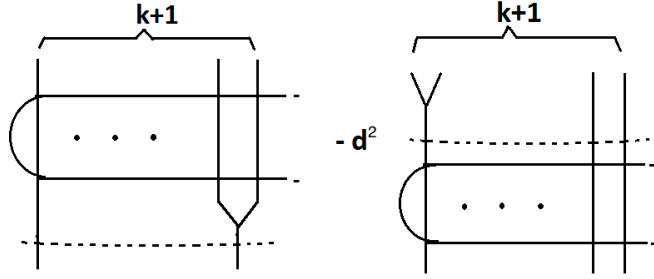

For $V^{\otimes k} \otimes (-)$, the left hand side of the relation (5.3) becomes

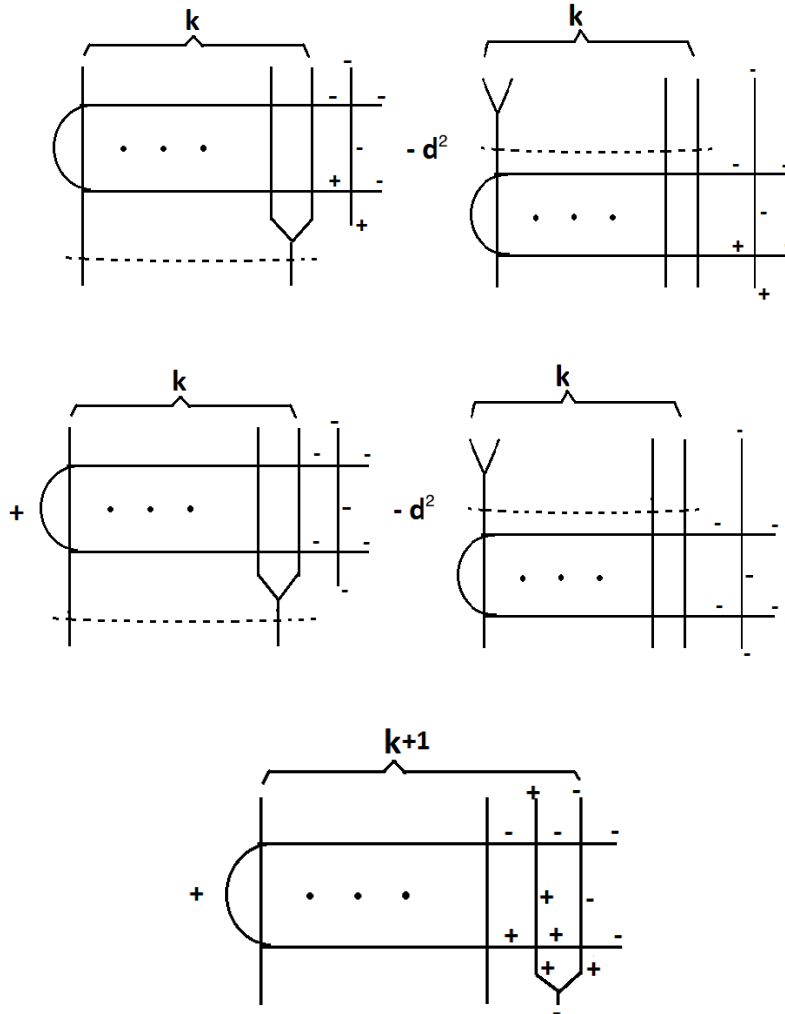

Using the relation (5.1) at the length k , it follows that the first two terms cancel. Using relations (5.2) and (5.3), it follows that the third and the fourth terms become

$$\mathcal{B}_{k-1} \otimes E_{-}^{+-}(a^2 g(u, k)).$$

The last term is

$$\mathcal{B}_{k-1} \otimes E_{-}^{+-}(a^2bc(-1)^{k+1}).$$

It is easy to see that

$$a^2g(u, k) + a^2bc(-1)^{k+1} = (-1)^k a^2bc + (-1)^{k+1} a^2bc(-1)^{k+1} = 0.$$

Hence the relation (5.3) is true on $V^{\otimes k} \otimes (-)$.

The next statement to prove is the relation (5.3) on $V^{\otimes k} \otimes (+)$. In order to prove this, it is sufficient to prove that the left hand side and the right hand side of the relation (5.3) are equal on $V^{\otimes k} \otimes (+)$. The left hand side of the relation (5.3) acting on $V^{\otimes k} \otimes (+)$ corresponds to the diagram

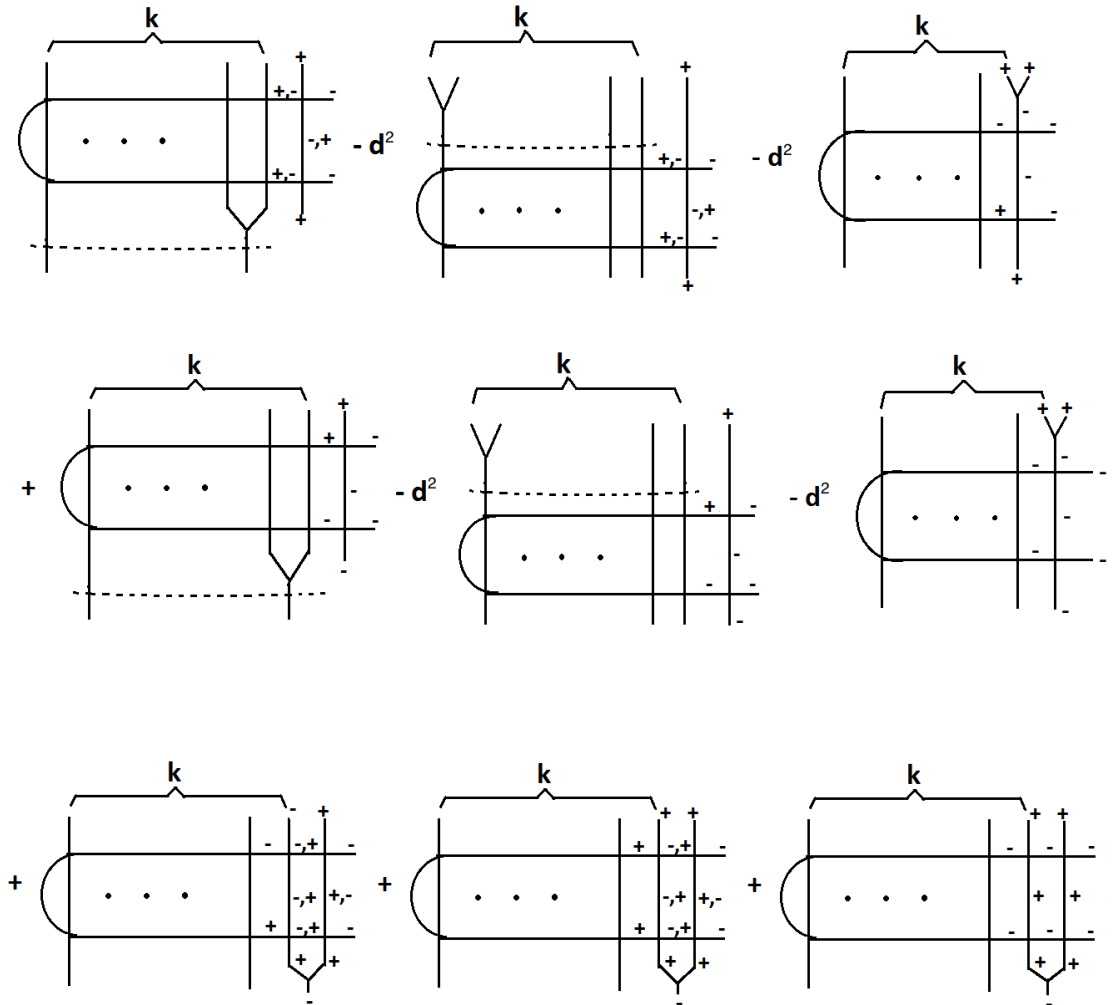

Using relations (5.2) and (5.3), the first two terms become

$$\mathcal{B}_{k-1} \otimes E_+^{++}(c^2 f(u, k) + b^2 g(u, k)),$$

and the first three terms are

$$\mathcal{B}_{k-1} \otimes E_+^{++}(c^2 f(u, k) + b^2 g(u, k) - d^2 ac(-1)^{k+1}).$$

Using the relation (5.4), the fourth and the fifth terms become

$$\begin{aligned} & \mathcal{B}_{k-1} \otimes E_-^{-+}(h_1(u, k)ac) + \mathcal{A}_k \otimes E_-^{++}(h_2(u, k)ac) \\ & + \mathcal{D}_{k-1} \otimes E_-^{++}(h_3(u, k)ac). \end{aligned}$$

The sixth to the last terms are

$$\begin{aligned} & \mathcal{B}_{k-1} \otimes E_-^{-+}((-1)^{k+1}(ab^2c + ac^3)) \\ & + \mathcal{A}_k \otimes E_-^{++}((-1)^{k+1}(b^2a^2 + a^2c^2)) \\ & + \mathcal{D}_{k-1} \otimes E_-^{++}((-1)^{k+1}(b^4 - d^2a^2)). \end{aligned}$$

Overall, the left hand side of the relation (5.3) is

$$\begin{aligned} & \mathcal{B}_{k-1} \otimes E_+^{++}(c^2 f(u, k) + b^2 g(u, k) - d^2 ac(-1)^{k+1}) \\ & + \mathcal{B}_{k-1} \otimes E_-^{-+}(h_1(u, k)ac + (-1)^{k+1}(ab^2c + ac^3)) \\ & + \mathcal{A}_k \otimes E_-^{++}(h_2(u, k)ac + (-1)^{k+1}(b^2c^2 + a^2c^2)) \\ & + \mathcal{D}_{k-1} \otimes E_-^{++}(h_3(u, k)ac + (-1)^{k+1}(b^4 - d^2a^2)). \end{aligned} \tag{5.10}$$

The right hand side of the relation (5.3) is $\mathcal{B}_k \otimes (g(u, k+1)E^+)$. Using similar

argument as in the part (II) and the relation (5.8), $\mathcal{B}_k \otimes (g(u, k + 1)E^+)$ becomes

$$\begin{aligned} & \mathcal{B}_{k-1} \otimes E_+^{++}(g(u, k + 1)ab) + \mathcal{B}_{k-1} \otimes E_-^{-+}(g(u, k + 1)ab) \\ & + \mathcal{A}_{k-1} \otimes E_-^{++}(g(u, k + 1)bc) + \mathcal{D}_{k-1} \otimes E_-^{++}(g(u, k + 1)bc). \end{aligned} \quad (5.11)$$

Using relations (5.5) and (5.6), it follows that the expression (5.10) is equal to (5.11). Hence the relation (5.3) is true on $V^{\otimes k} \otimes (+)$. Hence the relation (5.3) is true.

(IV). The relation (5.4) will be proved first on $V^{\otimes k} \otimes (-)$, and then on $V^{\otimes k} \otimes (+)$. In order to show the relation (5.4) is true on $V^{\otimes k} \otimes (-)$, it is sufficient to prove the left hand side and the right hand side of the relation (5.3) are equal on $V^{\otimes k} \otimes (-)$. The left hand side of the commutation relation (5.4) for the length $k + 1$ can be written out in diagrams as

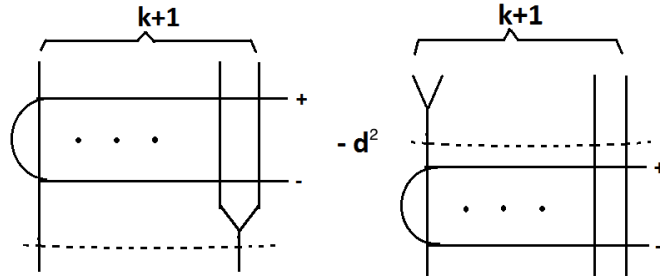

For $V^{\otimes k} \otimes (-)$, the left hand side of the relation (5.4) becomes

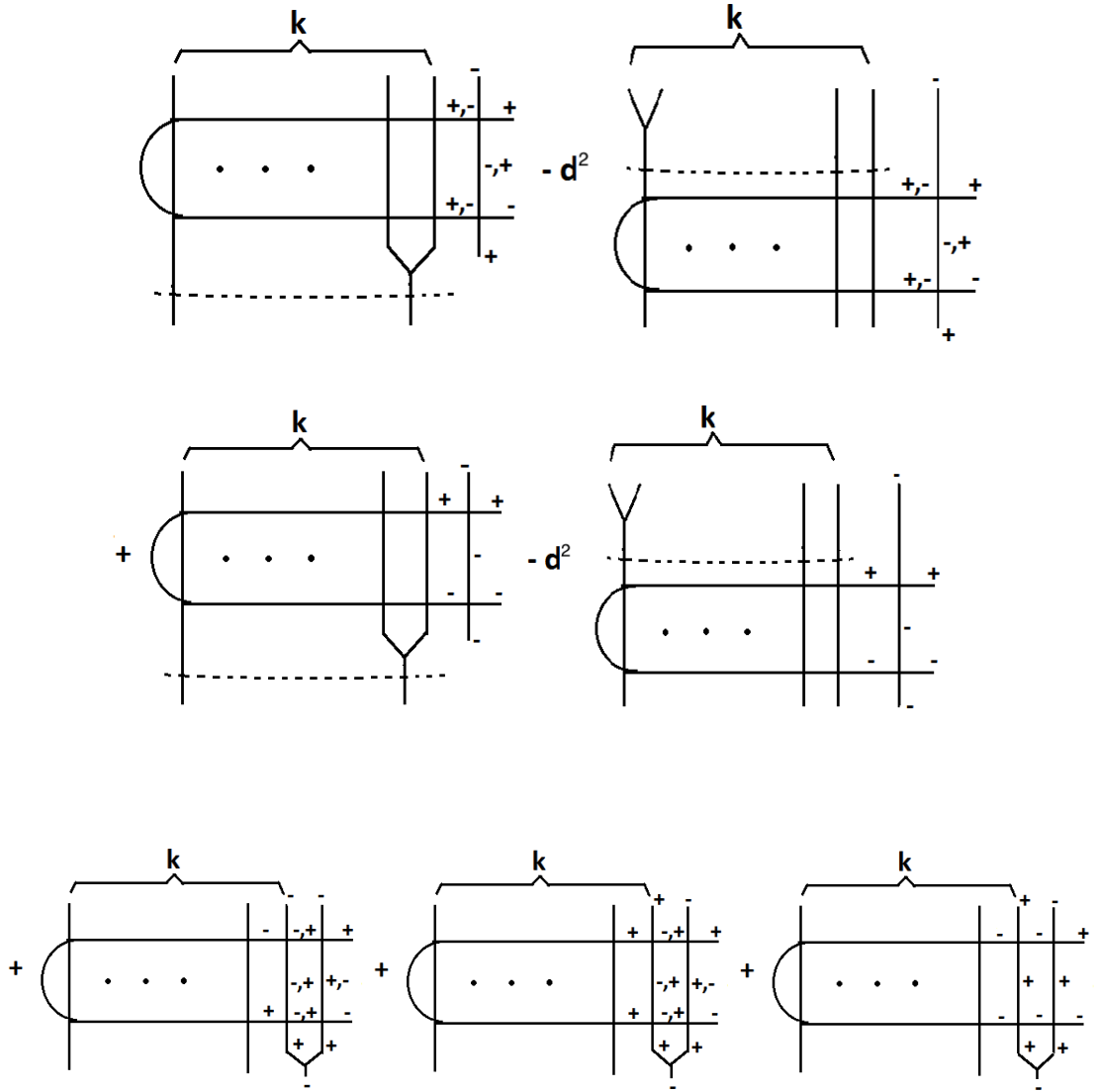

Using relations (5.2) and (5.3) at length k , it follows that the first two terms become

$$\mathcal{B}_{k-1} \otimes E_-^{+-}(bc(f(u, k) + g(u, k))).$$

Using the relation (5.4), it follows that the third and the fourth terms become

$$\mathcal{B}_{k-1} \otimes E_-^{--}(h_1(u, k)ab) + \mathcal{A}_{k-1} \otimes E_-^{+-}(h_2(u, k)ab) + \mathcal{D}_{k-1} \otimes E_-^{+-}(h_3(u, k)ab).$$

The last three terms are

$$\mathcal{B}_{k-1} \otimes E_-^{--}(2(-1)^{k+1}abc^2) + \mathcal{A}_{k-1} \otimes E_-^{+-}((-1)^{k+1}(bc^3 + a^2bc)) + \mathcal{D}_{k-1} \otimes E_-^{+-}((-1)^{k+1}b^3c).$$

Overall, the left hand side of the relation (5.4) is

$$\begin{aligned}
 & \mathcal{B}_{k-1} \otimes E_{-}^{-+}(bc(f(u, k) + g(u, k))) \\
 & + \mathcal{B}_{k-1} \otimes E_{-}^{-}(h_1(u, k)ab + 2(-1)^{k+1}abc^2) \\
 & + \mathcal{A}_{k-1} \otimes E_{-}^{+-}(h_2(u, k)ab + (-1)^{k+1}(bc^3 + a^2bc)) \\
 & + \mathcal{D}_{k-1} \otimes E_{-}^{+-}(h_3(u, k)ab + (-1)^{k+1}b^3c). \tag{5.12}
 \end{aligned}$$

Since the right hand side of the relation (5.4) on $V^{\otimes k} \otimes (-)$ is

$$\mathcal{B}_k \otimes (h_1(u, k + 1)E^{-}).$$

Using the relation (5.8), it can be written as

$$\begin{aligned}
 & \mathcal{B}_{k-1} \otimes E_{+}^{+-}(h_1(u, k + 1)ab) + \mathcal{B}_{k-1} \otimes E_{-}^{-}(h_1(u, k + 1)ab) \\
 & + \mathcal{A}_{k-1} \otimes E_{-}^{+-}(h_1(u, k + 1)bc) + \mathcal{D}_{k-1} \otimes E_{-}^{+-}(h_1(u, k + 1)bc). \tag{5.13}
 \end{aligned}$$

Using relations (5.5) and (5.6), it follows that the relation (5.12) is equal to the relation (5.13). Hence the relation (5.4) is true on $V^{\otimes k} \otimes (-)$.

Finally, the relation (5.4) acting on $V^{\otimes k} \otimes (+)$ will be proved. In order to achieve this, it is sufficient to prove that the left hand side and the right hand side of the relation (5.4) are equal on $V^{\otimes k} \otimes (+)$. The left hand side of the relation (5.4) corresponds to the diagram

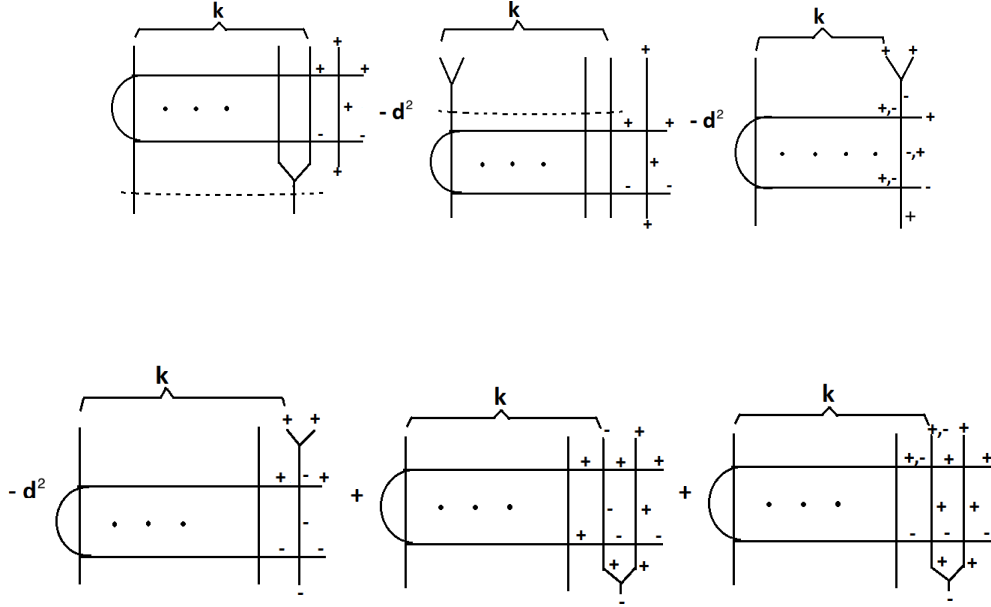

Using the relation (5.4), the first two terms become

$$\mathcal{B}_{k-1} \otimes E_+^{-+}(h_1(u, k)ab) + \mathcal{A}_{k-1} \otimes E_+^{++}(h_2(u, k)ab) + \mathcal{D}_{k-1} \otimes E_+^{++}(h_3(u, k)ab).$$

The rest of the terms are

$$\begin{aligned} &\mathcal{A}_{k-1} \otimes E_+^{++}(-1)^{k+1}(-d^2bc) + \mathcal{A}_{k-1} \otimes E_-^{-+}(-1)^{k+1}ab^2c + \mathcal{C}_{k-1} \otimes E_-^{++}(-1)^{k+1}(a^2b^2 - d^2ab) \\ &+ \mathcal{D}_{k-1} \otimes E_+^{++}d^2(-1)^{k+2}bc + \mathcal{D}_{k-1} \otimes E_-^{-+}((-1)^{k+1}ab^2c). \end{aligned}$$

Overall the left hand side is

$$\begin{aligned} &\mathcal{A}_{k-1} \otimes E_+^{++}(h_2(u, k)ab - (-1)^{k+1}d^2bc) + \mathcal{A}_{k-1} \otimes E_-^{-+}(-1)^{k+1}ab^2c \\ &+ \mathcal{B}_{k-1} \otimes E_+^{-+}(h_1(u, k)ab) + \mathcal{C}_{k-1} \otimes E_-^{++}(-1)^{k+1}(a^2b^2 - d^2ab) \\ &+ \mathcal{D}_{k-1} \otimes E_+^{++}(h_3(u, k)ab - d^2(-1)^{k+1}bc) + \mathcal{D}_{k-1} \otimes E_-^{-+}((-1)^{k+1}ab^2c). \end{aligned} \quad (5.14)$$

The right hand side of the relation (5.4) is

$$\mathcal{A}_k \otimes (h_2(u, k+1)E^+) + \mathcal{D}_k \otimes (h_3(u, k+1)E^+).$$

Using the same argument when deriving the relation (5.8), it follows

$$\mathcal{A}_k = \mathcal{A}_{k-1} \otimes E_+^+ a^2 + \mathcal{A}_{k-1} \otimes E_-^- b^2 + \mathcal{B}_{k-1} \otimes E_+^- ac + \mathcal{C}_{k-1} \otimes E_-^+ ac + \mathcal{D}_{k-1} \otimes E_-^- c^2, \quad (5.15)$$

$$\mathcal{D}_k = \mathcal{A}_{k-1} \otimes E_+^+ c^2 + \mathcal{B}_{k-1} \otimes E_+^- ac + \mathcal{C}_{k-1} \otimes E_-^+ ac + \mathcal{D}_{k-1} \otimes E_-^- a^2 + \mathcal{D}_{k-1} \otimes E_+^+ b^2. \quad (5.16)$$

Using relations (5.15) and (5.16), the right hand side of the relation (5.4) can be rewritten as

$$\begin{aligned} & \mathcal{A}_{k-1} \otimes E_+^{++} (h_2(u, k+1)a^2 + h_3(u, k+1)c^2) + \mathcal{A}_{k-1} \otimes E_-^{-+} h_2(u, k+1)b^2 \\ & + \mathcal{B}_{k-1} \otimes E_+^{-+} (h_2(u, k+1)ac + h_3(u, k+1)ac) + \mathcal{C}_{k-1} \otimes E_-^{++} (h_2(u, k+1)ac + h_3(u, k+1)ac) \\ & + \mathcal{D}_{k-1} \otimes E_+^{++} h_3(u, k+1)b^2 + \mathcal{D}_{k-1} \otimes E_-^{-+} (h_3(u, k+1)a^2 + h_2(u, k+1)c^2). \end{aligned} \quad (5.17)$$

It is easy to see that the relations (5.14) and (5.17) are equal. Hence the relation (5.4) is true on $V^{\otimes k} \otimes (+)$. Hence the relation (5.4) is true.

Hence all the relations in the induction step have been proved. By the mathematical induction, relations (5.1) – (5.4) are true. \square

Remark. *The commutation relation (5.1) was motivated by the relation $S_N \propto S^{\text{Bethe}}$ as discussed in the beginning of this section. The relations (5.1) have been confirmed numerically for different N and spectral parameter u . Commutation relations (5.2) – (5.4) are natural consequences of the relation (5.1). To see this, the input on the rightmost site of the relation (5.1) of size N will be restricted to $(+)$. Following the same argument as in part (I) of the proof of Theorem 6, it will give certain relation between \mathcal{A}_{N-1} , \mathcal{D}_{N-1} , \mathcal{A}_{N-2} , \mathcal{D}_{N-2} and $\mathcal{B}_{N-2} \otimes E^+$. Since the relation (5.1) is assumed to be true, the restriction of the relation (5.1) with its rightmost site as $(+)$ also has to be true. Hence the relation between \mathcal{A}_{N-1} , \mathcal{D}_{N-1} , \mathcal{A}_{N-2} , \mathcal{D}_{N-2} and $\mathcal{B}_{N-2} \otimes E^+$ has to be true. By further restricting the input on the second to the right site to be $(+)$, a relation will be obtained between \mathcal{A}_{N-2} , \mathcal{D}_{N-2} , \mathcal{A}_{N-3} , \mathcal{D}_{N-3} and $\mathcal{B}_{N-3} \otimes E^+$. This relation has to be true as well, and it has different coefficients*

compared to the first one. From these two relations, relations (5.2) and (5.3) can be obtained. The relation (5.4) can be obtained by analysing relations (5.2) and (5.3).

Theorem 6 has a simple consequence

Corollary 7. *The transfer matrix and the lattice supercharge satisfy the commutation relation*

$$S_N t_N(u) - d^2 t_{N-1}(u) S_N = 0,$$

where $d(u) = \sinh(u - \eta)$.

Proof. The transfer matrix can be written as

$$t_N(u) = \sinh(u - \eta) \mathcal{A}_N - \sinh(u + \eta) \mathcal{D}_N.$$

Using commutation relations between \mathcal{A}_N , \mathcal{D}_N and S_N , it is easy to verify the corollary. □

Now the second commutation relation $S_N \Omega_N = \hat{c} \mathcal{B}(\eta)_{N-1} \Omega_{N-1}$ in the beginning of this section will be proved using diagrams.

Proposition 8. *The lattice supercharge has the following property*

$$S_N \Omega_N = \hat{c} \mathcal{B}(\eta)_{N-1} \Omega_{N-1},$$

where $\hat{c} = 1/\sinh(\eta)^{2N-1}$ is a scalar function.

Proof. It is easy to show that

$$S_N \Omega_N = \sum_{i=1}^{N-1} (-1)^{i+1} (+ + \cdots - \cdots + +),$$

where the term $(-1)^i (+ + \cdots - \cdots + +)$ is in the Hilbert space $V^{\otimes N-1}$, and the minus sign is at the i th position in the space. On the other hand, $\mathcal{B}(\eta)_{N-1} \Omega_{N-1}$ can be expressed use diagrams as

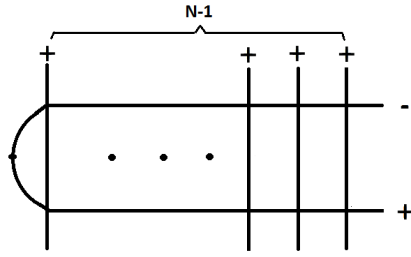

It is worth noting that $K^-(\eta)$ is

$$K^-(\eta) = \begin{bmatrix} 0 & 0 \\ 0 & \sinh(\eta) \end{bmatrix}.$$

This means that $K^-(\eta)$ will take (+) to zero and (-) to (-). Hence the diagram of $\mathcal{B}(\eta)_{N-1}\Omega_{N-1}$ can only be

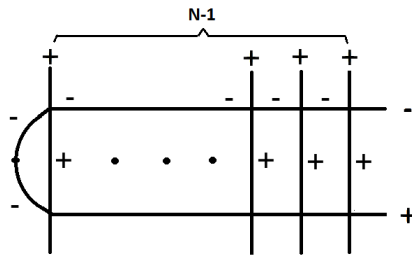

The rest of edges can only be completed as

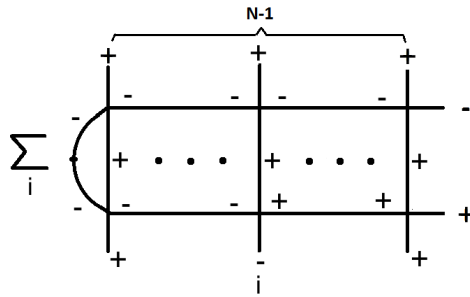

where the minus sign in the outcome is at the i th position, and the index i can take

values between 1 and $N - 1$. It is also worth noting that

$$R(\eta) = \sinh(2\eta) \begin{bmatrix} 1 & 0 & 0 & 0 \\ 0 & -1 & -1 & 0 \\ 0 & -1 & -1 & 0 \\ 0 & 0 & 0 & 1 \end{bmatrix}.$$

Hence, by calculating the coefficients associated with the above diagram, and sum over the index i from 1 to $N - 1$, it gives

$$\mathcal{B}_{N-1}(\eta)\Omega_{N-1} = \sinh(\eta) \sinh(2\eta)^{2N-2} \sum_{i=1}^{N-1} (-1)^{i+1} (+ + \dots - \dots + +).$$

Hence

$$S_N \Omega_N = \hat{c} \mathcal{B}_{N-1}(\eta) \Omega_{N-1}.$$

□

Finally, the relation $S_N \propto S_N^{Bethe}$ will be proved.

Theorem 9. *Let $\{v_1, \dots, v_M\}$ be any set of Bethe roots of the transfer matrix $t(u)$ defined in the relation 5.2, then we have*

$$S_N \mathcal{B}_N(v_1) \dots \mathcal{B}_N(v_M) \Omega_N = \frac{d^2(v_1) \dots d^2(v_M)}{\sinh(\eta)^{2N-1}} \mathcal{B}_{N-1}(v_1) \dots \mathcal{B}_{N-1}(v_M) \mathcal{B}_{N-1}(\eta) \Omega_{N-1}.$$

Proof. This is an application of Theorem 6 and Proposition 8. □

5.3 SUSY on open chain

This section will study the spin-half open XXZ chain Hamiltonian with anti-diagonal boundary matrices. Since this Hamiltonian has anti-diagonal boundary matrices, it will be denoted as $H_{XXZ,Ad}^{(N)}$. The Hamiltonian $H_{XXZ,Ad}^{(N)}$ will be constructed from

the local supercharge p .

$$p = \frac{1}{\sqrt{2}} \begin{bmatrix} 2 & -1 & -1 & -1 \\ 1 & 1 & 1 & -2 \end{bmatrix}.$$

The lattice supercharge S_N is defined as in relation (2.4). This lattice supercharge is nilpotent. The Hamiltonian $H_{XXZ,Ad}^{(N)}$ is defined as

$$H_{XXZ,Ad}^{(N)} = S_{N+1} S_{N+1}^\dagger + S_N^\dagger S_N.$$

By the discussion of Section 2.1, $H_{XXZ,Ad}^{(N)}$ has lattice SUSY. $H_{XXZ,Ad}^{(N)}$ can be written out using Pauli matrices as

$$H_{XXZ,Ad}^{(N)} = -\frac{1}{2} \sum_{i=1}^{N-1} (\sigma_i^x \otimes \sigma_{i+1}^x + \sigma_i^y \otimes \sigma_{i+1}^y - \frac{1}{2} \sigma_i^z \otimes \sigma_{i+1}^z) + \frac{1}{2} \sigma_1^x + \frac{1}{2} \sigma_N^x + \frac{3N+11}{4} \mathbb{I}.$$

$H_{XXZ,Ad}^{(N)}$ is related to a transfer matrix with open boundary condition. Let the transfer matrix be defined as in Section 3.4 with R -matrix defined in relation (3.1) and K -matrices defined using $K^{-(\frac{1}{2})}(u)$ and $K^{+(\frac{1}{2})}(u)$ in Section 3.5.1. The parameters of the transfer matrix are chosen to be $\alpha_\pm = -\eta$, $\beta_\pm = 0$, $\theta_\pm = 0$ and $\eta = \frac{2i\pi}{3}$. This transfer matrix will be denoted as $\hat{t}(u)$. This set of parameters satisfy the condition (3.26), and hence the map S^{Bethe} exists for the transfer matrix. It is important to note that the map S^{Bethe} in this section implies only the pairing of Bethe roots, since the eigenstates can not be constructed for $\hat{t}(u)$ using TQ equations in Section 3.5. By the discussion in Section 4.2, the Hamiltonian associated with $\hat{t}(u)$ can be normalised such that the map S^{Bethe} take one set of Bethe roots of length N to another set of Bethe roots of length $N-1$ with the same eigenvalue. The normalised Hamiltonian is

$$H_{XXZ,general}^{(N)'} = \frac{\hat{t}'(0)}{H_2(0)} - \frac{\frac{dH_2(u)}{du}|_{u=0}}{H_2(0)} + \frac{2N}{\sinh(2\eta)},$$

where $H_2(u)$ is defined in Section 4.2 with $\epsilon_1 = \epsilon_2 = \epsilon_3 = 1$. The following result

can be confirmed numerically

$$H_{XXZ,Ad}^{(N)} = -\frac{\sqrt{3}i}{4}H_{XXZ,general}^{(N)'} + 2\mathbb{I}.$$

This suggests that $H_{XXZ,Ad}^{(N)}$ is an integrable open XXZ chain Hamiltonian. This also suggests the eigenvalue of $H_{XXZ,Ad}^{(N)}$ can be solved by the same Bethe equations of $\hat{t}(u)$. Since $H_{XXZ,Ad}^{(N)}$ is related to $H_{XXZ,general}^{(N)'}$ by multiplying and adding constant, the map S^{Bethe} also take one set of Bethe roots of $H_{XXZ,Ad}^{(N)}$ to another set of Bethe roots of $H_{XXZ,Ad}^{(N-1)}$ with the same eigenvalue, By the discussion in Section 4.4, this suggests S^{Bethe} is proportional to S_N . This relation is difficult to check, since the eigenstate corresponds to certain eigenvalue can not be constructed using TQ equations. However, the eigenstate with non-degenerate eigenvalue will be easy to determine from direct diagonalisation. It has been confirmed numerically that

$$S^{Bethe} \propto S_N,$$

on the eigenstates with non-degenerate eigenvalue. It has also been confirmed numerically that

$$S_N \hat{t}(u) \propto \hat{t}(u) S_{N-1}.$$

Let $\mathcal{A}_N(u)$, $\mathcal{B}_N(u)$, $\mathcal{C}_N(u)$ and $\mathcal{D}_N(u)$ be the operators associated with $\hat{t}(u)$. By the discussion in the remark before Corollary 7, the above commutation relation implies the existence of commutation relations between S_N and operators $\mathcal{A}_N(u)$, $\mathcal{B}_N(u)$, $\mathcal{C}_N(u)$ and $\mathcal{D}_N(u)$. The following conjecture has been confirmed numerically.

Conjecture 1. *The following commutation relations are true*

$$\begin{aligned}
 S_N \mathcal{A}_N(u) - d^2 \mathcal{A}_{N-1}(u) S_N &= \mathcal{A}_{N-1} \otimes (f_1(u, N) E^+) + \mathcal{A}_{N-1} \otimes (f_2(u, N) E^-) \\
 &\quad + \mathcal{B}_{N-1} \otimes (f_3(u, N) E^+) + \mathcal{B}_{N-1} \otimes (f_4(u, N) E^-) \\
 &\quad + \mathcal{C}_{N-1} \otimes (f_5(u, N) E^+) + \mathcal{C}_{N-1} \otimes (f_6(u, N) E^-) \\
 &\quad + \mathcal{D}_{N-1} \otimes (f_7(u, N) E^+) + \mathcal{D}_{N-1} \otimes (f_8(u, N) E^-),
 \end{aligned} \tag{5.18}$$

$$\begin{aligned}
 S_N \mathcal{B}_N(u) - d^2 \mathcal{B}_{N-1}(u) S_N &= \mathcal{A}_{N-1} \otimes (g_1(u, N) E^+) + \mathcal{A}_{N-1} \otimes (g_2(u, N) E^-) \\
 &\quad + \mathcal{B}_{N-1} \otimes (g_3(u, N) E^+) + \mathcal{B}_{N-1} \otimes (g_4(u, N) E^-) \\
 &\quad + \mathcal{C}_{N-1} \otimes (g_5(u, N) E^+) + \mathcal{C}_{N-1} \otimes (g_6(u, N) E^-) \\
 &\quad + \mathcal{D}_{N-1} \otimes (g_7(u, N) E^+) + \mathcal{D}_{N-1} \otimes (g_8(u, N) E^-),
 \end{aligned} \tag{5.19}$$

$$\begin{aligned}
 S_N \mathcal{C}_N(u) - d^2 \mathcal{C}_{N-1}(u) S_N &= \mathcal{A}_{N-1} \otimes (-g_8(u, N) E^+) + \mathcal{A}_{N-1} \otimes (-g_7(u, N) E^-) \\
 &\quad + \mathcal{B}_{N-1} \otimes (-g_6(u, N) E^+) + \mathcal{B}_{N-1} \otimes (-g_5(u, N) E^-) \\
 &\quad + \mathcal{C}_{N-1} \otimes (-g_4(u, N) E^+) + \mathcal{C}_{N-1} \otimes (-g_3(u, N) E^-) \\
 &\quad + \mathcal{D}_{N-1} \otimes (-g_2(u, N) E^+) + \mathcal{D}_{N-1} \otimes (-g_1(u, N) E^-),
 \end{aligned} \tag{5.20}$$

$$\begin{aligned}
 S_N \mathcal{D}_N(u) - d^2 \mathcal{D}_{N-1}(u) S_N &= \mathcal{A}_{N-1} \otimes (-f_8(u, N) E^+) + \mathcal{A}_{N-1} \otimes (-f_7(u, N) E^-) \\
 &\quad + \mathcal{B}_{N-1} \otimes (-f_6(u, N) E^+) + \mathcal{B}_{N-1} \otimes (-f_5(u, N) E^-) \\
 &\quad + \mathcal{C}_{N-1} \otimes (-f_4(u, N) E^+) + \mathcal{C}_{N-1} \otimes (-f_3(u, N) E^-) \\
 &\quad + \mathcal{D}_{N-1} \otimes (-f_2(u, N) E^+) + \mathcal{D}_{N-1} \otimes (-f_1(u, N) E^-),
 \end{aligned} \tag{5.21}$$

where $d = \sinh(u - \eta)$. Other scalar functions are defined as

$$\left\{ \begin{array}{l} f_1(u, N) = (-1)^N i \frac{\sqrt{2}\sqrt{3}}{8} (x^2 - x^{-2}) \\ f_2(u, N) = (-1)^N \frac{\sqrt{2}(i\sqrt{3}-3)(i\sqrt{3}+1+2x^4)}{32x^2} \\ f_3(u, N) = -(-1)^N \frac{\sqrt{2}(i\sqrt{3}-3)(i\sqrt{3}+1+2x^2)}{32x} \\ f_4(u, N) = -(-1)^N \frac{\sqrt{2}(i\sqrt{3}+3)(-i\sqrt{3}+1+2x^2)}{32x} \\ f_5(u, N) = (-1)^N \frac{\sqrt{2}(i\sqrt{3}+3)(-i\sqrt{3}+1+2x^2)}{32x} \\ f_6(u, N) = -(-1)^N i \frac{\sqrt{2}\sqrt{3}}{8} (x - x^{-1}) \\ f_7(u, N) = 0 \\ f_8(u, N) = (-1)^N \frac{3\sqrt{2}}{8} \end{array} \right. ,$$

and

$$\left\{ \begin{array}{l} g_1(u, N) = -(-1)^N i \frac{\sqrt{2}\sqrt{3}}{8} (x - x^{-1}) \\ g_2(u, N) = (-1)^N \frac{\sqrt{2}(i\sqrt{3}-3)(i\sqrt{3}+1+2x^2)}{32x} \\ g_3(u, N) = (-1)^N \frac{3\sqrt{2}}{8} \\ g_4(u, N) = -(-1)^N \frac{3\sqrt{2}}{8} \\ g_5(u, N) = (-1)^N \frac{3\sqrt{2}}{8} \\ g_6(u, N) = 0 \\ g_7(u, N) = -(-1)^N i \frac{\sqrt{2}\sqrt{3}}{8} (x - x^{-1}) \\ g_8(u, N) = (-1)^N \frac{\sqrt{2}(i\sqrt{3}+3)(-i\sqrt{3}+1+2x^2)}{32x} \end{array} \right. ,$$

where $x = e^u$.

Conjecture 1 implies the following results.

Conjecture 2. Let the operator $\hat{B}(u)$ be defined as

$$\hat{B}(u) = i\sqrt{3} \cosh(u + \eta)(\mathcal{A}_N - \mathcal{D}_N) - \sinh(2u + 2\eta)(\mathcal{B}_N - \mathcal{C}_N).$$

The operator satisfies the following relations

$$[\hat{B}(u), \hat{B}(v)] = 0, \quad (5.22)$$

$$\hat{B}_{N-1}(u)S_N \propto S_N \hat{B}_N(u). \quad (5.23)$$

The operator $\hat{B}(u)$ satisfies similar properties with the creation operator $\mathcal{B}(u)$ of $H_{XXZ,diagonal}^{(N)}$. However, it is still unclear how $\hat{B}(u)$ will help in the construction of an analogue of the algebraic Bethe ansatz of $H_{XXZ,Ad}^{(N)}$. It will be interesting to prove these conjectures, and construct the algebraic Bethe ansatz of $H_{XXZ,Ad}^{(N)}$. The results could be compared with [82], which offers another way to construct eigenstates on transfer matrices with non-diagonal K -matrices.

Chapter 6

Conclusion and Future Work

This thesis has studied two type of lattice models, the supersymmetric lattice models and the integrable vertex model. Lattice models with lattice SUSY and lattice models with integrability have been constructed. On certain models, the structure of the lattice SUSY has been incorporated into the quantum inverse scattering method.

Based on the results in [52] [67], a new construction of the supersymmetric XXZ chain Hamiltonian on the open boundary condition has been given. This new construction is limited to the Hamiltonian with the same boundary matrices on both sides. A natural next step is to generalise the construction to the Hamiltonian with different boundary matrices. It has been shown that there is no constant zero-energy state for the family of Hamiltonian given in [67]. It will be an interesting problem to check for any constant ground state for the new Hamiltonian in Section 2.3. Another direction is to generalise the construction of the supersymmetric XXZ chain Hamiltonian to the higher-spins cases.

Hamiltonians associated with other integrable lattice models have also been studied, such as the XXZ chain Hamiltonian for arbitrary spins with generic boundary matrices and the spin-half XXZ chain with diagonal boundary matrices. By analysing these models, the symmetry of Bethe equations have been found which suggest the existence of lattice SUSY.

The results in [67] have enabled the construction of an integrable spin chain Hamiltonian with the lattice SUSY, which is denoted as $H_{XXZ,diagonal}^{(N)}$. Motivated by [52] [70], a lattice supercharge S_N has been compared with the map S^{Bethe} induced from the Bethe equations of $H_{XXZ,diagonal}^{(N)}$. Using McCoy's method, the map S^{Bethe} is calculated and the relation $S_N \propto S^{Bethe}$ has been confirmed numerically. This provided a connection between the lattice SUSY and the algebraic Bethe ansatz of $H_{XXZ,diagonal}^{(N)}$. A further connection is the commutation relation $\mathcal{B}_{N-1}(u)S_N = d^2S_N\mathcal{B}_N(u)$, where $d = \sinh(u - \eta)$. This relation is among a family of commutation relations between the lattice supercharge and operators $\mathcal{A}_N, \mathcal{B}_N, \mathcal{C}_N$ and \mathcal{D}_N arising from the algebraic Bethe ansatz. These relations have been proved using diagrams. One of the consequence of the commutation relations is the commutativity between the transfer matrix associated with $H_{XXZ,diagonal}^{(N)}$ and S_N . Finally, a spin-half XXZ chain Hamiltonian with anti-diagonal boundary matrices has been studied, which is denoted by $H_{XXZ,Ad}^{(N)}$. $H_{XXZ,Ad}^{(N)}$ has lattice SUSY. It has also been confirmed numerically that the transfer matrix associated with $H_{XXZ,Ad}^{(N)}$ commutes with the supercharge S_N . A family of commutation relations between S_N and operators $\mathcal{A}_N, \mathcal{B}_N, \mathcal{C}_N$ and \mathcal{D}_N was also been found and confirmed numerically.

These two examples $H_{XXZ,diagonal}^{(N)}$ and $H_{XXZ,Ad}^{(N)}$ suggest that the lattice supercharge of any spin-half open XXZ chain Hamiltonians satisfies certain commutation relations with $\mathcal{A}_N, \mathcal{B}_N, \mathcal{C}_N$ and \mathcal{D}_N . Since a systematic construction of all the lattice supercharge for the spin-half open XXZ chain Hamiltonian has been given in Section 2.3. It will be useful to obtain the operators $\mathcal{A}_N, \mathcal{B}_N, \mathcal{C}_N$ and \mathcal{D}_N corresponding to every choice of parameters in the lattice supercharge, and to obtain the commutation relations between these operators and the lattice supercharge S_N . In the case of $H_{XXZ,diagonal}^{(N)}$, the commutation relation $\mathcal{B}_{N-1}(u)S_N = d^2S_N\mathcal{B}_N(u)$ is a necessary condition of $S_N \propto S^{Bethe}$. There is another choice of the reference state with the creation operator \mathcal{C}_N in the algebraic Bethe ansatz, which implies the existence of another map $S^{Bethe'}$. This new map $S^{Bethe'}$ will also give a pairing between the eigenstate with Bethe roots $\{v_1, \dots, v_M\}$ of length N and the eigenstate with Bethe roots v_1, \dots, v_M, η of length $N - 1$. Hence it will be interesting to see whether there

exists another lattice supercharge $S'_N : V^{\otimes N} \rightarrow V^{\otimes N-1}$ such that $S'_N \propto S^{Bethe'}$, and whether the necessary condition $\mathcal{C}_{N-1}(u)S'_N \propto S'_N\mathcal{C}_N(u)$ is true.

So far the study has focused on the action of S_N on the eigenstates constructed from Bethe roots. It is natural to ask how S_N acts on other eigenstates. In [96], the open XXZ chain Hamiltonian with quantum group symmetry is studied. The eigenstates constructed from Bethe roots are the highest weight vectors in the representation of the quantum groups. The Bethe equations of this Hamiltonian have a symmetry which induces the map S^{Bethe} . However, the construction of the lattice supercharge is not known. It would be interesting to construct the lattice supercharge S_N for this Hamiltonian, and study the relation between S_N and the quantum group symmetry.

Bibliography

- [1] H. Bethe. Zur theorie der metalle. *Zeitschrift für Physik*, 71(3):205–226, 1931.
- [2] C. N. Yang and C. P. Yang. One-dimensional chain of anisotropic spin-spin interactions. 1. proof of bethe’s hypothesis for ground state in a finite system. *Phys. Rev.*, 150:321–327, 1966.
- [3] C. N. Yang and C. P. Yang. One-dimensional chain of anisotropic spin-spin interactions. 2. properties of the ground-state energy per lattice site for an infinite system. *Phys. Rev.*, 150:327–339, 1966.
- [4] C. N. Yang and C. P. Yang. One-dimensional chain of anisotropic spin-spin interactions. 3. applications. *Phys. Rev.*, 151:258–264, 1966.
- [5] Rodney J Baxter. Partition function of the eight-vertex lattice model. *Annals of Physics*, 70(1):193 – 228, 1972.
- [6] Rodney J Baxter. One-dimensional anisotropic heisenberg chain. *Annals of Physics*, 70(2):323 – 337, 1972.
- [7] Rodney Baxter. Eight-vertex model in lattice statistics and one-dimensional anisotropic heisenberg chain. 1. some fundamental eigenvectors. *Annals of Physics*, 76(1):1 – 24, 1973.
- [8] Rodney Baxter. Eight-vertex model in lattice statistics and one-dimensional anisotropic heisenberg chain. 2. equivalence to a generalised ice-type lattice model. *Annals of Physics*, 76(1):25 – 47, 1973.

- [9] Rodney Baxter. Eight-vertex model in lattice statistics and one-dimensional anisotropic heisenberg chain. 3. eigenvectors of the transfer matrix and hamiltonian. *Annals of Physics*, 76(1):48 – 71, 1973.
- [10] Elliott H. Lieb. *Exact solution of the problem of the entropy of two-dimensional Ice*, pages 449–451. Springer Berlin Heidelberg, Berlin, Heidelberg, 2004.
- [11] Elliott H. Lieb. Residual entropy of square ice. *Phys. Rev.*, 162:162–172, 1967.
- [12] Elliott H. Lieb. Exact solution of the f model of an anti-ferroelectric. *Phys. Rev. Lett.*, 18:1046–1048, 1967.
- [13] Elliott H. Lieb. *Exact solution of the two-dimensional slater KDP model of a ferroelectric*, pages 457–459. Springer Berlin Heidelberg, Berlin, Heidelberg, 2004.
- [14] E. K. Sklyanin, L. A. Takhtadzhyan, and L. D. Faddeev. Quantum inverse problem method. i. *Theoretical and Mathematical Physics*, 40(2):688–706, 1979.
- [15] L A Takhtadzhan and Lyudvig D Faddeev. The quantum method of the inverse problem and the heisenberg xyz model. *Russian Mathematical Surveys*, 34(5):11, 1979.
- [16] P. P. Kulish and E. K. Sklyanin. *Quantum spectral transform method recent developments*, pages 61–119. Springer Berlin Heidelberg, Berlin, Heidelberg, 1982.
- [17] V. e. Korepin. Analysis of a bilinear relation for the six-vertex model. *Sov. Phys. Dokl.*, 27:612–613, 1982.
- [18] V. E. Korepin. Calculation of norms of bethe wave functions. *Communications in Mathematical Physics*, 86(3):391–418, 1982.
- [19] A. G. Izergin and V. E. Korepin. The quantum inverse scattering method approach to correlation functions. *Communications in Mathematical Physics*, 94(1):67–92, 1984.

- [20] A. G. Izergin. Partition function of the six-vertex model in a finite volume. *Soviet Physics Doklady*, 32:878, 1987.
- [21] V. E. Korepin, N. M. Bogoliubov, and A. G. Izergin. *Quantum inverse scattering method and correlation functions*. 1993.
- [22] L. Faddeev. *From integrable models to quantum groups*, pages 89–115. Springer Berlin Heidelberg, Berlin, Heidelberg, 1990.
- [23] Klaus Fabricius and Barry M. McCoy. *Evaluation Parameters and Bethe Roots for the Six-Vertex Model at Roots of Unity*, pages 119–144. Birkhäuser Boston, Boston, MA, 2002.
- [24] Klaus Fabricius and Barry M McCoy. An elliptic current operator for the eight-vertex model. *Journal of Physics A: Mathematical and General*, 39(48):14869, 2006.
- [25] E. K. Sklyanin. Boundary conditions for integrable quantum systems. *Journal of Physics A Mathematical General*, 21:2375–2389, 1988.
- [26] N. Kitanine, J. M. Maillet, and V. Terras. Form factors of the XXZ Heisenberg spin-half finite chain. *Nuclear Physics B*, 554:647–678, 1999.
- [27] N. Kitanine, J. M. Maillet, and V. Terras. Correlation functions of the XXZ Heisenberg spin-half chain in a magnetic field. *Nuclear Physics B*, 567:554–582, 2000.
- [28] N. Kitanine, J. M. Maillet, N. A. Slavnov, and V. Terras. Spin-spin correlation functions of the XXZ spin-half Heisenberg chain in a magnetic field. *Nuclear Physics B*, 641:487–518, 2002.
- [29] N. Kitanine, J. M. Maillet, N. A. Slavnov, and V. Terras. LETTER TO THE EDITOR: Emptiness formation probability of the XXZ spin half Heisenberg chain at $\Delta = \frac{1}{2}$. *Journal of Physics A Mathematical General*, 35:L385–L388, 2002.

- [30] N. Kitanine, J. M. Maillet, N. A. Slavnov, and V. Terras. Master equation for spin spin correlation functions of the XXZ chain. *Nuclear Physics B*, 712:600–622, 2005.
- [31] N. Kitanine, K. Kozłowski, J. M. Maillet, N. A. Slavnov, and V. Terras. On correlation functions of integrable models associated with the six-vertex R-matrix. *Journal of Statistical Mechanics: Theory and Experiment*, 1:01022, 2007.
- [32] Nikita A Slavnov. The algebraic bethe ansatz and quantum integrable systems. *Russian Mathematical Surveys*, 62(4):727, 2007.
- [33] N. Yu. Reshetikhin. A method of functional equations in the theory of exactly solvable quantum systems. *Letters in Mathematical Physics*, 7(3):205–213, 1983.
- [34] R. J. Baxter. Eight-vertex model in lattice statistics. *Phys. Rev. Lett.*, 26:832–833, 1971.
- [35] R. J. Baxter. *Exactly solved models in statistical mechanics*. Academic Press, 1982.
- [36] Marco Rossi and Robert Weston. A generalized q -operator for $uq(\mathfrak{sl}_2)$ vertex models. *Journal of Physics A: Mathematical and General*, 35(47):10015, 2002.
- [37] C. Korff. A Q -operator identity for the correlation functions of the infinite XXZ spin-chain. *Journal of Physics A Mathematical General*, 38:6641–6657, 2005.
- [38] R. Weston. An algebraic setting for defects in the XXZ and Sine-Gordon models. *arXiv:1006.1555*, 2010.
- [39] H. Boos, M. Jimbo, T. Miwa, F. Smirnov, and Y. Takeyama. Hidden Grassmann structure in the XXZ model II: Creation operators. *Commun. Math. Phys.*, 286:875–932, 2009.
- [40] Vladimir V. Bazhanov, Tomasz Lukowski, Carlo Meneghelli, and Matthias Staudacher. A shortcut to the Q -operator. *J. Stat. Mech.*, 1011:P11002, 2010.

- [41] Rouven Frassek and Istvn M. Szcsnyi. Q-operators for the open heisenberg spin chain. *Nuclear Physics B*, 901:229 – 248, 2015.
- [42] Vladimir V. Bazhanov, Sergei L. Lukyanov, and Alexander B. Zamolodchikov. Integrable structure of conformal field theory, 1. quantum KdV theory and thermodynamic Bethe ansatz. *Commun. Math. Phys.*, 177:381–398, 1996.
- [43] Vladimir V. Bazhanov, Sergei L. Lukyanov, and Alexander B. Zamolodchikov. Integrable structure of conformal field theory. 2. Q operator and DDV equation. *Commun. Math. Phys.*, 190:247–278, 1997.
- [44] Vladimir V. Bazhanov, Sergei L. Lukyanov, and Alexander B. Zamolodchikov. Integrable structure of conformal field theory. 3. The Yang-Baxter relation. *Commun. Math. Phys.*, 200:297–324, 1999.
- [45] David Hernandez and Michio Jimbo. Asymptotic representations and drinfeld rational fractions. *Compositio Mathematica*, 148(5):1593–1623, 2012.
- [46] Edward Frenkel and David Hernandez. Baxter’s relations and spectra of quantum integrable models. *Duke Math. J.*, 164(12):2407–2460, 2015.
- [47] Michio Jimbo and Tetsuji Miwa. Algebraic analysis of solvable lattice models. 1994.
- [48] Paul Fendley, Kareljan Schoutens, and Jan de Boer. Lattice models with N=2 supersymmetry. *Phys. Rev. Lett.*, 90:120402, 2003.
- [49] Paul Fendley, Kareljan Schoutens, and Bernard Nienhuis. Lattice fermion models with supersymmetry. *J. Phys.*, A36:12399–12424, 2003.
- [50] Xiao Yang and Paul Fendley. Non-local spacetime supersymmetry on the lattice. *Journal of Physics A: Mathematical and General*, 37(38):8937, 2004.
- [51] C. Matsui. Dynamical supersymmetry on the XXX spin chain. *ArXiv e-prints:1504.05676*, 2015.
- [52] C. Hagendorf and P. Fendley. The eight-vertex model and lattice supersymmetry. *Journal of Statistical Physics*, 146:1122–1155, 2012.

- [53] F C Alcaraz, M N Barber, M T Batchelor, R J Baxter, and G R W Quispel. Surface exponents of the quantum xxz, ashkin-teller and potts models. *Journal of Physics A: Mathematical and General*, 20(18):6397, 1987.
- [54] G. Kuperberg. Another proof of the alternating sign matrix conjecture. *Internat. Math. Res. Notices*, 1996.
- [55] A. V. Razumov and Y. G. Stroganov. Spin chains and combinatorics. *Journal of Physics A Mathematical General*, 34:3185–3190, 2001.
- [56] A. V. Razumov and Y. G. Stroganov. Spin chains and combinatorics: twisted boundary conditions. *Journal of Physics A Mathematical General*, 34:5335–5340, 2001.
- [57] P. Di Francesco and P. Zinn-Justin. Around the razumov-stroganov conjecture: Proof of a multi-parameter sum rule. *Electronic Journal of Combinatorics*, 12(1 R):1–27, 2005.
- [58] P. Di Francesco and P. Zinn-Justin. LETTER TO THE EDITOR: The quantum Knizhnik Zamolodchikov equation, generalized Razumov Stroganov sum rules and extended Joseph polynomials. *Journal of Physics A Mathematical General*, 38:L815–L822, 2005.
- [59] P. Di Francesco, P. Zinn-Justin, and J.-B. Zuber. Sum rules for the ground states of the O(1) loop model on a cylinder and the XXZ spin chain. *Journal of Statistical Mechanics: Theory and Experiment*, 8:08011, 2006.
- [60] M. Kasatani and V. Pasquier. On polynomials interpolating between the stationary state of a O(n) model and a Q.H.E. ground state. *Communications in Mathematical Physics*, 276:397–435, 2007.
- [61] A. V. Razumov, Y. G. Stroganov, and P. Zinn-Justin. Polynomial solutions of qKZ equation and ground state of XXZ spin chain at $\Delta = -1/2$. *Journal of Physics A Mathematical General*, 40:11827–11847, 2007.

- [62] L. Cantini and A. Sportiello. Proof of the Razumov-Stroganov conjecture. *Journal of Combinatorial Theory Series A*, 2010.
- [63] Luigi Cantini and Andrea Sportiello. A one-parameter refinement of the razumovstroganov correspondence. *Journal of Combinatorial Theory, Series A*, 127:400 – 440, 2014.
- [64] C. Hagendorf. Spin chains with dynamical Lattice supersymmetry. *Journal of Statistical Physics*, 150:609–657, 2013.
- [65] Christian Hagendorf. The nineteen-vertex model and alternating sign matrices. *Journal of Statistical Mechanics: Theory and Experiment*, 2015(1):P01017, 2015.
- [66] Christian Hagendorf and Alexi Morin-Duchesne. Symmetry classes of alternating sign matrices in a nineteen-vertex model. *Journal of Statistical Mechanics: Theory and Experiment*, 2016(5):053111, 2016.
- [67] C. Hagendorf and J. Liénardy. Open spin chains with dynamic lattice supersymmetry. *Journal of Physics A Mathematical General*, 50(18):185202, 2017.
- [68] J. Dubail and J.-M. Stéphan. Universal behavior of a bipartite fidelity at quantum criticality. *Journal of Statistical Mechanics: Theory and Experiment*, 3:L03002, 2011.
- [69] D. Meidinger and V. Mitev. Dynamic Lattice supersymmetry in spin chains of $gl(nm)$ spin chains. *Journal of Statistical Physics*, 156:1199–1220, 2014.
- [70] C. Hagendorf, T. B. Fokkema, and L. Huijse. Bethe ansatz solvability and supersymmetry of the M_2 model of single fermions and pairs. *Journal of Physics A Mathematical General*, 47:485201, 2014.
- [71] R. Weston and J. Yang. Lattice Supersymmetry in the Open XXZ Model: An Algebraic Bethe Ansatz Analysis. *ArXiv e-prints:1709.00442*, September 2017.
- [72] Edward Witten. Constraints on supersymmetry breaking. *Nuclear Physics B*, 202(2):253 – 316, 1982.

- [73] Cesar Gmez, Martm Ruiz-Altaba, and German Sierra. *Quantum Groups in Two-Dimensional Physics*. Cambridge Monographs on Mathematical Physics. Cambridge University Press, 1996.
- [74] W.-L. Yang, R. I. Nepomechie, and Y.-Z. Zhang. Q-operator and T- Q relation from the fusion hierarchy. *Physics Letters B*, 633:664–670, 2006.
- [75] Anatoli Klimyk and Konrad Schmudgen. *Quantum Groups and Their Representations*. Springer-Verlag Berlin Heidelberg, 1997.
- [76] V. Chari and A.N. Pressley. *A Guide to Quantum Groups*. Cambridge University Press, 1995.
- [77] L. D. Faddeev. How algebraic Bethe ansatz works for integrable model. In *Relativistic gravitation and gravitational radiation. Proceedings, School of Physics, Les Houches, France, September 26-October 6, 1995*, pages pp. 149–219, 1996.
- [78] P. P. Kulish and E. K. Sklyanin. Algebraic structures related to reflection equations. *Journal of Physics A Mathematical General*, 25:5963–5975, 1992.
- [79] Rafael I. Nepomechie. Boundary quantum group generators of type a. *Letters in Mathematical Physics*, 62(2):83–89, 2002.
- [80] Luca Mezincescu, Rafael I. Nepomechie, and V. Rittenberg. Bethe ansatz solution of the fateev-zamolodchikov quantum spin chain with boundary terms. *Physics Letters A*, 147(1):70 – 78, 1990.
- [81] A. G. Bytsko. On integrable Hamiltonians for higher spin XXZ chain. *Journal of Mathematical Physics*, 44:3698–3717, 2003.
- [82] G. Filali and N. Kitanine. Spin chains with non-diagonal boundaries and trigonometric SOS model with reflecting end. *SIGMA*, 7:012, 2011.
- [83] Luc Frappat, Rafael Nepomechie, and Eric Ragoucy. Complete Bethe ansatz solution of the open spin-s XXZ chain with general integrable boundary terms. *J. Stat. Mech.*, 0709:P09009, 2007.

- [84] Y.-k. Zhou. Row transfer matrix functional relations for Baxter's eight-vertex and six-vertex models with open boundaries via more general reflection matrices. *Nuclear Physics B*, 458:504–532, 1996.
- [85] J. de Gier and A. Nichols. The two-boundary Temperley-Lieb algebra. *ArXiv Mathematics e-prints*, 2007.
- [86] J. de Gier, A. Nichols, P. Pyatov, and V. Rittenberg. Magic in the spectra of the XXZ quantum chain with boundaries at $\Delta=0$ and $\Delta=-1/2$. *Nuclear Physics B*, 729:387–418, 2005.
- [87] J. de Gier and P. Pyatov. Bethe ansatz for the Temperley-Lieb loop model with open boundaries. *Journal of Statistical Mechanics: Theory and Experiment*, 3:002, 2004.
- [88] A. Nichols. LETTER: Structure of the two-boundary XXZ model with non-diagonal boundary terms. *Journal of Statistical Mechanics: Theory and Experiment*, 2:L02004, 2006.
- [89] P. D. Francesco, O. Golinelli, and E. Guitter. Meanders and the Temperley-Lieb algebra. *Communications in Mathematical Physics*, 186:1–59, 1997.
- [90] P. Di Francesco. Meander Determinants. *ArXiv High Energy Physics - Theory e-prints*, December 1996.
- [91] J. A. Minahan and K. Zarembo. The Bethe ansatz for script $N = 4$ super Yang-Mills. *Journal of High Energy Physics*, 3:013, 2003.
- [92] R. I. Nepomechie. Bethe ansatz solution of the open XXZ chain with non-diagonal boundary terms. *Journal of Physics A Mathematical General*, 37:433–440, 2004.
- [93] R. Murgan, R. I. Nepomechie, and C. Shi. Exact solution of the open XXZ chain with general integrable boundary terms at roots of unity. *Journal of Statistical Mechanics: Theory and Experiment*, 8:6, 2006.

- [94] R. I. Nepomechie. An inhomogeneous T-Q equation for the open XXX chain with general boundary terms: completeness and arbitrary spin. *Journal of Physics A Mathematical General*, 46:442002, 2013.
- [95] R. I. Nepomechie and F. Ravanini. Completeness of the Bethe ansatz solution of the open XXZ chain with non-diagonal boundary terms. *Journal of Physics A Mathematical General*, 36:11391–11401, 2003.
- [96] V. Pasquier and H. Saleur. Common structures between finite systems and conformal field theories through quantum groups. *Nuclear Physics B*, 330(2):523 – 556, 1990.