

SHIELDING AND GROUNDING IN LARGE DETECTORS*

Veljko Radeka

Brookhaven National Laboratory, Upton, NY 11973-5000 (radeka@bnl.gov)

Abstract

Shielding effectiveness as a function of shield thickness and conductivity vs the type and frequency of the interference field is described. Noise induced in transmission lines by ground loop driven currents in the shield is evaluated and the importance of low shield resistance is emphasized. Some measures for prevention of ground loops and isolation of detector-readout systems are discussed.

1. INTRODUCTION

Prevention of electromagnetic interference (EMI), or "noise pickup", is an important design aspect in large detectors in accelerator environments. It is of particular concern in detector subsystems where signals have a large dynamic range or where high accuracy position interpolation is performed. Calorimeters are very sensitive to coherent noise induced in groups of readout channels where energy sums are formed, covering a large dynamic range. There are several potential noise sources and means of transmission:

- 1) Noise from digital circuits generated locally on a single front end read-out board on the detector;
- 2) electromagnetic radiation in the space around the detector generated by other detector subsystems, power supplies, silicon-controlled rectifiers, machinery, etc.;
- 3) noise induced by penetrations into the detector enclosure (e.g., cryostat) and the front end readout electronics located on the detector;
- 4) currents coming through ground loops, of which the detector enclosure and the front end electronics are a part, caused by any apparatus and machinery outside the detector.

Problem 1) of internally generated noise is being addressed by a careful layout and filtering on the board(s), shielding of preamplifiers, and by minimizing digital operations on the board.

The effects of externally generated noise in the form of EM radiation are best reduced by a well designed Faraday shield ("cage"). The effects of noise currents flowing through the shields, due to ground loops, are also reduced by the Faraday cage.

Ideally, ground loops should be avoided entirely. In practice, preventing formation of ground loops means to increase a ground loop impedance over most of the frequency range as much as possible.

*This work is supported by the U.S. Department of Energy; Contract No. DE-AC02-98CH10886.

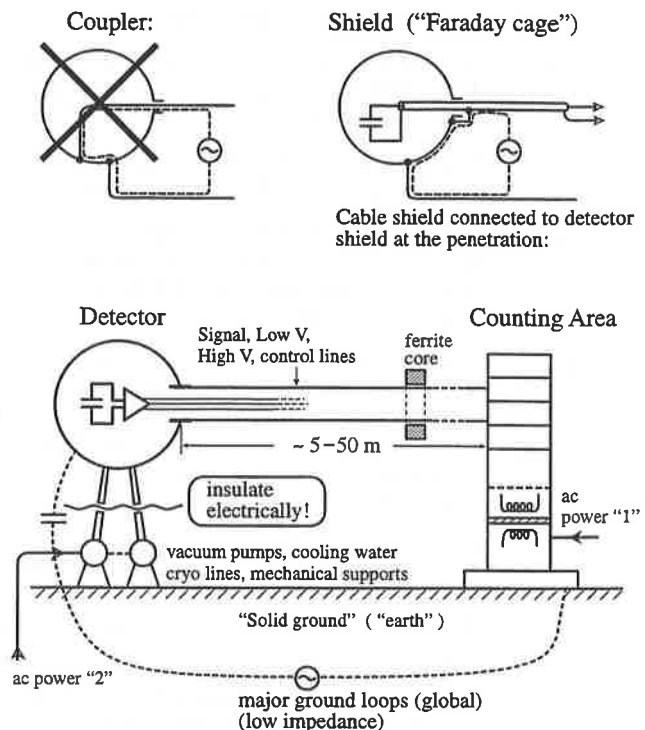

Figure 1. An illustration of shielding and ground loop control concepts.

Figure 1 illustrates some of the basics of shielding and ground loop control. No leads of any kind should enter a Faraday cage without their shield being connected to the detector enclosure at the penetration, otherwise a lead connected to the enclosure would inject noise (it presents a coupler) into detector electrodes and front end electronics. If the detector enclosure (i.e., its front end electronics) and the readout electronics in the counting area have to be connected electrically and not only by optical links, then the cable shield should have a low resistance and a high inductance to minimize the noise at the receiving end due to the ground loop voltage. Ground loop currents in the enclosure walls and the transmission lines will be minimized by isolating the detector enclosure from the surrounding.

In Section 2, some basics of shielding against external EM fields are reviewed. In Section 3, noise pickup in transmission lines from ground loop voltages and currents is discussed. In Section 4, potential ground loops in a large detector subsystem are illustrated in the example of the ATLAS liquid argon calorimeter. Some practical steps for isolation are described in Section 5, and in Section 6, the question of the safety ground is addressed.

2. SHIELDING EFFECTIVENESS AGAINST EM RADIATION

2.1 Thick Shields ($t \geq \delta$)

Shielding properties of enclosures are analyzed in detail in Ref. 1. Only some main points are emphasized here. A hermetic detector or an electronics enclosure of highly conductive material, such as copper or aluminum, provides very high attenuation against external EM fields in the frequency range from a few kHz up to very high frequencies. The shielding effect is obtained by reflection and absorption of the EM wave. Attenuation by reflection of an external plane EM wave at normal incidence to the shield, with wave impedance Z_w is:

$$A_r = 20 \log \frac{|Z_w|}{4|Z_s|} \quad [\text{dB}] \quad (1)$$

where Z_s is characteristic impedance of the shield material,

$$|Z_s| = (\omega\mu/\sigma)^{1/2} = 3.7 \times 10^{-7} f^{1/2} \quad [\Omega] \quad (2)$$

(for copper)

where $\omega = 2\pi f$ is the frequency, μ is the permeability, and σ is the conductivity of the shielding material. Z_s can be expressed in terms of the skin depth $\delta = 2/(\omega\mu\sigma)^{1/2}$ as,

$$|Z_s| = \frac{\sqrt{2}}{\delta\sigma} \quad (3)$$

$1/\delta\sigma$ is simply dc sheet resistivity per square of the shield layer, one skin depth thick. Characteristic impedance of the shield is very low, $Z_s \approx 1\text{m}\Omega$ at 10 MHz; $0.1\text{m}\Omega$ at 100 kHz.

The wave impedance Z_w (the ratio of the electric field and the magnetic field) depends on the nature of the source (electric or magnetic antenna) and the distance from the source. In the far field, i.e., distance greater than $\lambda/2\pi$, it approaches the impedance of the free space (and air), 377Ω . At $f = 10$ MHz, $\lambda = 30$ m, so that for frequencies less than 10 MHz, most detectors will be in near field conditions. For an "electric antenna" (high voltage and low current), the wave impedance varies as $1/r$, and for a "magnetic antenna" (high current and low voltage), it varies as r in the near field $r < \lambda/2\pi$. Taking the above values for Z_s and for $Z_w = 377\Omega$, the shielding effectiveness in the far field, due to reflection, is:

$$A_r = 9.4 \times 10^4 = 99.5 \text{ dB at } 10 \text{ MHz}$$

$$= 9.4 \times 10^5 = 119.4 \text{ dB at } 100 \text{ kHz.}$$

The attenuation is higher in the near field for an electric source, and much lower for a magnetic source at low frequencies[3].

Shielding attenuation by absorption due to skin effect is,

$$A_a = 6.2 t (\omega\mu\sigma)^{1/2} = 8.7 t/\delta \quad [\text{dB}] \quad (4)$$

(for copper)

where t is thickness of the shield.

A copper shield 0.5 mm thick provides a far field attenuation at 100 kHz of only about 21 dB by absorption, and nearly 120 dB by reflection. In this case, absorption becomes dominant only above ~ 5 MHz. The reflection attenuation increases with the angle of incidence.

2.2 Very Thin Shields ($t \ll \delta$)

For very thin shields, multiple reflections of the magnetic field component within the shield reduce shielding effectiveness. Total attenuation, including multiple reflections, is then given by[1],

$$A = 20 \log \frac{|Z_w|}{4|Z_s|} + 20 \log(2 \sinh \frac{t}{\delta}) \quad (5)$$

For very thin shields $\sinh(t/\delta) \approx t/\delta$, and by substituting Eq. (3) for Z_s , and $1/\sigma$ for shield dc resistivity per square ρ_{\square} ,

$$A_r \approx 20 \log \frac{|Z_w|\sigma t}{2\sqrt{2}} = 20 \log \frac{|Z_w|}{2\sqrt{2}\rho_{\square}} \quad (6)$$

Thus, for very thin shields, attenuation due to reflection is determined simply by the ratio of the wave impedance and the sheet resistivity of the shield. Low mass shields, such as aluminized Mylar windows on gas proportional chambers, can still provide very useful shielding. For example, 1000 Å (0.1 μm) of aluminum, which is about 1/800th of the skin depth at 1 MHz, gives $\rho_{\square} \approx 0.25 \Omega/\text{square}$ and $A_r \approx 533 = 55$ dB.

A closer inspection shows that Eq. (1) for thick shields is approximately valid down to $t/\delta = 0.2$, with an error of 9.6 dB.

2.3 The Role of Apertures (Gaps) in the Shield

Any gaps in the shield interrupt the flow of currents which are essential for field attenuation provided by the shield. Attenuation by an aperture in the shield is given by[2],

$$A_{ap} = 20 \log \frac{\lambda}{2L} \quad [\text{dB}] \quad (7)$$

where λ is the wavelength and L is the longest dimension of the aperture, regardless of its shape. This indicates significant field penetration, which increases with frequency. For example, for $L = 10$ cm, at 10 MHz, A_{ap} is barely above 40 dB. The attenuation reduces to zero dB at the wave guide cutoff frequency, $\lambda/2L = 1$. The attenuation can be increased if the openings form a wave guide of some length (e.g., a honeycomb structure).

At lower frequencies (1 kHz–1 MHz), it is possible to achieve very high shielding attenuation. At high frequencies (>10 MHz) shielding effectiveness will be aperture-limited. The importance of electrical continuity of any shield cannot be overemphasized. This is also important for ground loop-driven currents (section 3).

a) Single ended PA

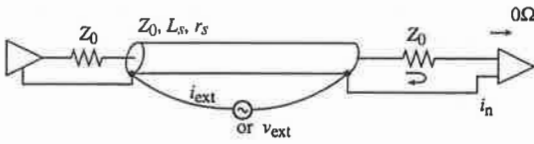

- * Δv in the shield = $i_{ext} (j\omega L_s + r_s)$ for $r_s \ll Z_0$
- * Δv in center lead = $i_{ext} \cdot j\omega L_s$
- * emf in the receiver = $i_{ext} \cdot r_s$
- * noise current $i_n = \frac{i_{ext}}{2} = \frac{r_s}{2Z_0}$ for current in the shield
- * noise current $i_n = \frac{v_{ext}}{2Z_0} \cdot \frac{r_s}{r_s + j\omega L_s}$ for voltage in the loop

b) "Common Mode"

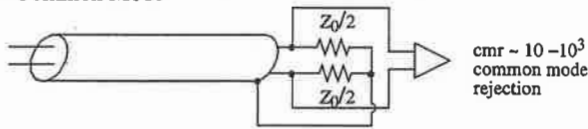

Noise currents reduced by $\frac{cmr}{4}$ compared to a)

c) Double Shield

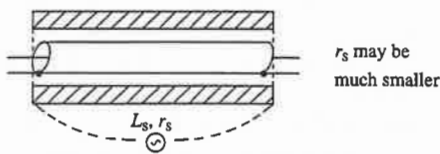
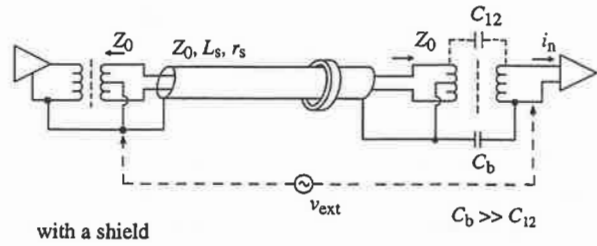

figure 2. Noise pickup in cables due to currents caused by ground loops.

3. NOISE INDUCED IN SHIELDED CONDUCTORS BY GROUND LOOP CURRENTS

Derivation of noise current into the receiver at the end of a coaxial transmission line is outlined in Fig. 2. It is based on the magnetic coupling between the center lead and the shield. It can be shown that the mutual inductance between the two is equal to the (self)inductance of the shield[1]. The potential difference between the two ends of the shield is determined by the ground loop current and the resistance and inductance of the shield. The induced emf in the center lead is equal to the voltage across the shield inductance only. The noise current into the receiver is the result of the potential difference at the receiver end of the line. The shield resistance in relation to the characteristic impedance of the transmission line determines the magnitude of the noise current into the receiver. In many cases the ground loop voltage, v_{ext} , between the sending end and the receiving end is generated with a very low impedance. The ratio of the shield resistance to the shield inductance is then a determining parameter for the receiver noise current.

For shielded, balanced transmission lines, noise rejection is improved by the common mode rejection of the



with a shield

$$i_n = \frac{v_{ext}}{Z_0/2} \cdot \frac{r_s}{r_s + j\omega L_s} \cdot \frac{1}{cmr} \leftarrow \text{common mode rejection ratio}$$

Figure 3. Balanced transmission line with high rejection of ground loop noise.

receiver (i.e., $cmr/4$). A principal role of double shielding for terminated transmission lines is to reduce further the shield resistance, r_s . Figure 3 illustrates a transmission line connection for analog signals with a very high dynamic range ($\sim 5 \times 10^4$), which has been proven in practice. Inductance of the shield can be artificially increased by several turns on a ferrite core. The noise current in Fig. 3 is given for a direct connection in place of C_b . A capacitance, C_b , of 100-300 pF reduces further the shield currents at lower frequencies, and prevents unbalancing the transformer due to the stray capacitance, C_{12} , at high frequencies. Differential amplifiers are also commonly used instead of transformers, with somewhat lower rejection of the noise and crosstalk.

The transmission line case illustrates the importance of a low shield resistance. The same conclusion can be reached, albeit in more complex geometry, for any Faraday cage and, in particular, for any configuration where front end electronics is located in a shielded enclosure attached to the detector. This is the case for almost all subsystems in LHC experiments. Any gaps in the enclosures are particularly important. This is where the well developed technology[2] of rf gaskets may have to be applied. Special attention has to be paid to galvanic compatibility of the metals used, to ensure low contact resistances over the lifetime of the experiment. In particular, contacts with bare aluminum have to be avoided. Aluminum has to be chromate or tin-plated or, if that is not practical, a brush-on coating has to be applied to contact surfaces.

Prevention of noise injection by ground loop currents is usually more difficult than shielding against EM radiation.

4. POTENTIAL GROUND LOOPS IN A LARGE DETECTOR SUBSYSTEM

Large detector subsystems have a large number of connections to the surrounding world for signals, monitoring, cooling, power, etc., that if left to chance, a bewildering network of ground loops will arise. Even in cases where all signal transmission to and from the detector is digital, and via optical links, power and ser-

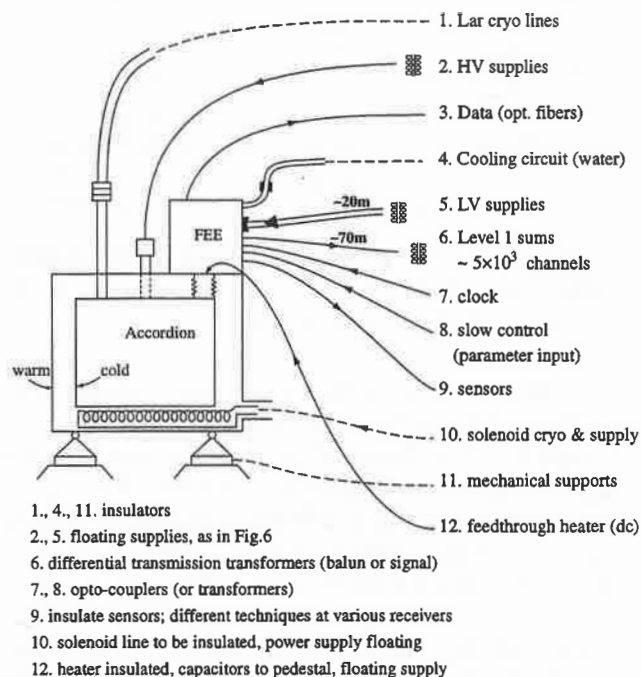

Figure 4. Vital lines in the ATLAS Liquid Argon Calorimeter (i.e., potential ground loops).

ices connections may create loops which will inject noise currents into the critical contact areas of the detector and front end electronics enclosures. The solution that offers some degree of control is to isolate, electrically, the detector. This is illustrated for the case of the ATLAS Liquid Argon Calorimeter in Fig. 4.

An objection is sometimes made that a large object, such as a cryostat, has a capacitance of several nanofarads to the support structure and other subsystems. However, at some intermediate frequencies, say 100 kHz, this presents several orders of magnitude higher impedance than the resistance of a direct connection. Noise at frequencies lower than the center frequency of the signal processing chain is important, since it can be induced by various paths of currents through nonhermetic shields, into the wide band stages of front end electronics, such as analog memories and ADCs.

5. AN OUTLINE OF SOME ISOLATION MEASURES

Figure 5 illustrates some of the practical configurations for communicating signals, power and various sensor lines with the interior of a Faraday cage. The intent of all of them is to divert any ground loop currents into the shield (enclosure). In examples 2 and 3, the impedance of the connecting lines is increased by a balun transformer, or by resistors in each line where the current in the leads is very low.

Figure 6 illustrates floating dc supplies for low voltage (high power) and for high voltage (very low currents).

1. Coaxial Cables

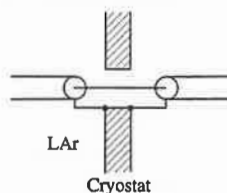

- Shield connected to cryostat before penetrating Faraday cage
- Short connection, low inductance
- Performed on standard feedthroughs

2. Power Supplies

- Capacitors with short leads, close to cryostat low inductance connection
- No net DC Current in Balun to avoid saturating Ferrite (pass power and return). In magnetic field up to ~ 300 – 400 gauss, use 3D3 type ferrite

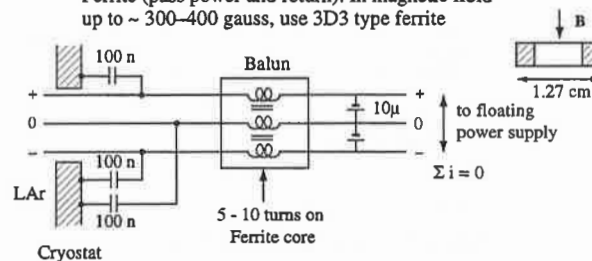

3. Probes, HV

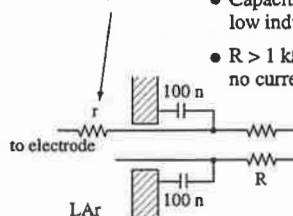

- Capacitors with short leads, close to cryostat, low inductance connection
- $R > 1 \text{ k}\Omega$ can be replaced by $L > 1 \text{ mH}$ when no current flows

Figure 5. Rules for Entering a Shielded Detector Enclosure (e.g., cryostat).

Figure 7 shows the connection for multiple remotely sensed power supplies. The "common" can only be at the location of front end electronics (to avoid making interdependent feedback loops).

6. THE QUESTION OF SAFETY GROUND

Prevention of ground loop currents, by increasing the impedance of any loop as much as possible, leads to the following guidelines:

- All detector subsystems will be electrically isolated;
- There will be no connection to ground other than "Safety Network";
- There will be no connection between different detector subsystems.

(These have been adopted as the primary guidelines in the ATLAS Policy on Grounding.)

The goal of the isolation is to prevent numerous possible ground loops (illustrated in Figs. 1 and 4), to allow checking for inadvertent connections to various "grounds" (i.e., objects which appear to be near zero potential, such as the experiment support structure), and to allow for a safety connection to a single point without creating a ground loop.

1. LV Supplies <50V

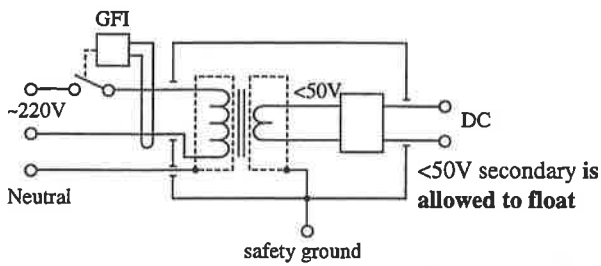

2. HV Supplies > 50V → ~kV Supplies, low current

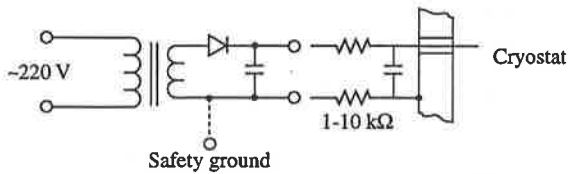

3. Supplementary safety grounding:
high impedance at low voltage

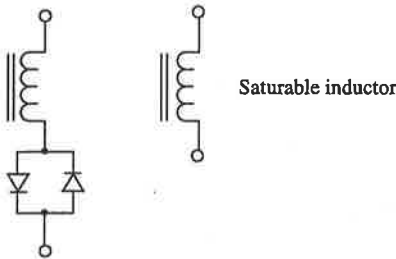
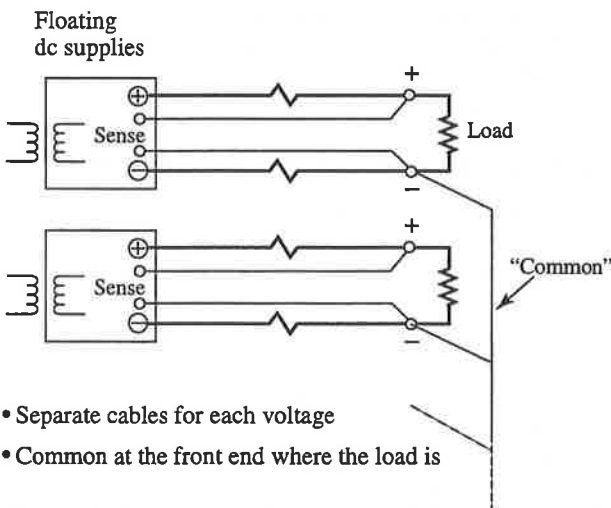

Figure 6. An illustration of “floating” low voltage and high voltage power supplies and supplementary safety grounding.



- Separate cables for each voltage
- Common at the front end where the load is

Figure 7. Connection of remote multiple power supplies.

Once the subsystem isolation has been ensured, a well-defined safety ground must be established. To what point?

In the case of the LAr Calorimeter, a dominant consideration is to preserve from EMI the Level 1 trigger

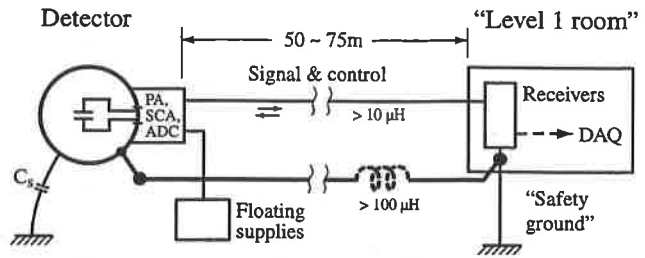

Figure 8. Safety ground for an isolated detector subsystem with any copper connections to the level 1 trigger electronics (and/or DAQ).

sum signals. This is the only analog transmission of electrical signals from the calorimeter. It will be accomplished by differential transmission, with high common mode rejection (push-pull drivers, shielded twin lead transmission lines, differential receivers). It is reasonable to require that any potential difference between the sending end and the receiving end be minimized over most of the frequency range. At high frequencies, the current through the shielding braid should be minimized. Thus the safety ground (reference point) should be at the location of Level 1 signal receivers. Each cryostat will have a low resistance connection to that point, as illustrated in Fig. 8 (a part of that connection could be the common braids of Level 1 cables from each crate).

In case of a subsystem where all signal communications (including sensors and controls) are by optical links, and floating power supplies are used, safety ground could be some other point. However, potential differences between adjacent subsystems are minimized when they are connected to the same reference point.

If a part of a subsystem could be inadvertently separated during maintenance, and a possible safety question arises, an additional connection could be made to the same reference point, but via a nonlinear network (high impedance for small signals) as in Fig. 6.

ACKNOWLEDGMENTS

Discussions on shielding and grounding principles and practice with R. Chase, J. Colas, C. de La Taille, P. Rehak, H. Williams, and B. Yu are gratefully acknowledged.

REFERENCES

1. H. W. Ott, Noise Reduction Techniques in Electronic Systems, John Wiley & Sons, 1976.
2. Product Design & Shielding Selection Guide, 1994 Instrument Specialties, Delaware Water Gap, PA 18327.
3. The role of magnetic materials at low frequencies is discussed in Ref.1, p.159.