

Ultra High Vacuum Test Setup for Electron Gun

M L Pandiyar¹, M Prasad, S K Jain, Ramesh Kumar and P R Hannurkar
Raja Ramanna Centre for Advanced Technology, Indore- 452 103 (M.P.)

E-mail: mohanp@cat.ernet.in

Abstract. Ultra High Vacuum (UHV) test setup for electron gun testing has been developed. The development of next generation light sources and accelerators require development of klystron as a radio frequency power source, and in turn electron gun. This UHV electron gun test setup can be used to test the electron guns ranging from high average current, quasi-continuous wave to high peak current, single pulse etc. An electron gun has been designed, fabricated, assembled and tested for insulation up to 80 kV under the programme to develop high power klystron for future accelerators. Further testing includes the electron emission parameters characterization of the cathode, as it determines the development of a reliable and efficient electron gun with high electron emission current and high life time as well. This needs a clean ultra high vacuum to study these parameters particularly at high emission current. The cathode emission current, work function and vapour pressure of cathode surface material at high temperature studies will further help in design and development of high power electron gun. The UHV electron gun test setup consists of Turbo Molecular Pump (TMP), Sputter Ion Pump (SIP), pressure gauge, high voltage and cathode power supplies, current measurement device, solenoid magnet and its power supply, residual gas analyser etc. The ultimate vacuum less than 2×10^{-9} mbar was achieved. This paper describes the UHV test setup for electron gun testing.

1. Introduction

The electron beam from electron gun is employed in klystron device to generate very high RF power for many high energy accelerator applications. The quality of the electron beam directly impacts the output power and efficiency of klystron. The electron gun test setup is developed. The setup helps to provide a condition to accelerate the electron beam and to find out electron gun perveance, design gun accelerating voltage, cathode operating temperature, work function of cathode, space charge limitations, beam current measurements and life of cathode which will depend upon the evaporation rate of cathode material. The test setup includes a Turbo Molecular Pump (TMP) of 500 litre/sec. capacity, Sputter Ion Pump (SIP) of 70 litre/sec. capacity, a quadruple mass analyzer, a UHV gate valve, faraday cup etc. The schematic diagram of the UHV test setup for electron gun is shown in figure 1.

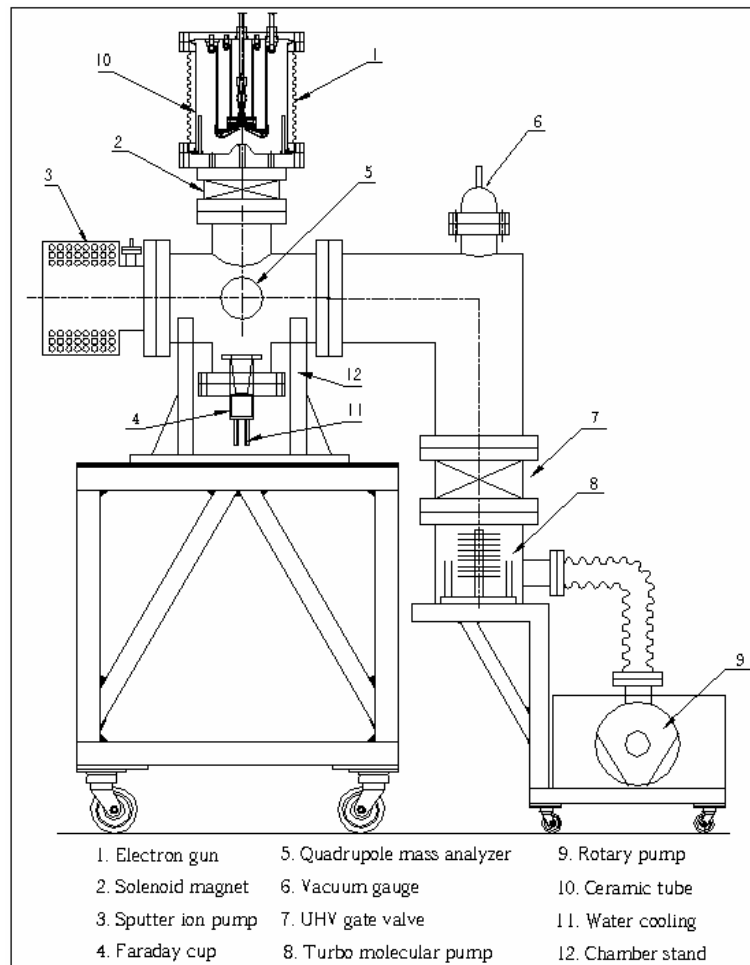

Figure 1. The schematic diagram of UHV test setup for electron gun

2. Ultra high vacuum system

The UHV system has been built by using UHV compatible materials. The materials used in the system are low out-gased, even at elevated working temperature, while baking of system and electron gun operation. All flanges are knife-edge conflat type, copper gaskets were used as vacuum sealing material. The vacuum system is similar to Ref. [1]. The ceramic to metal joints are made in hydrogen brazing furnace. The gate valve, gauge, pumps, glass windows all are UHV compatible.

The quality of vacuum affects the performance of the high power electron gun. The vacuum was achieved by using a 500 litre/sec. Pfeiffer make TMP backed by rotary pump. The pressure was measured by a Pfeiffer make cold cathode inverted magnetron gauge. The quadruple mass analyzer was used to measure the species of gas molecules. A 70 litre/sec. in house built SIP was as a work horse pump for this UHV system. In this system we have achieved vacuum less than 2×10^{-9} mbar. The cathode was heated to high temperature to facilitate the emission of electron, from the surface, the vacuum deteriorated to 2×10^{-8} mbar. In cathode heater powered condition, the vacuum was achieved less than 2×10^{-8} mbar. The quadrupole mass analyser measures changes in vacuum and helps to operate the system.

3. Cleanliness of vacuum system

The cleanliness is very important to maintain a proper clean vacuum. The clean vacuum is maintained by using good quality vacuum materials and fabrication techniques. The clean and contamination free

materials have low out-gassing, and low vapour pressure. The main source of out-gassing, in electron gun, is cathode. The quality of the vacuum will be monitored on regular basis by quadruple mass analyser. The care of the vacuum system is taken at highest level to avoid any contamination while assembly and operation of system.

4. Electron gun

Electron gun at 50 keV, 1500 mA has been designed using EGUN [2] software and fabricated [3, 4]. This is Pierce type design and which provides laminar beam with minimum beam loss. The gun electrodes, shapes and spacing is optimized with a spherical cathode of diameter 8 mm for maximum beam current and to avoid any electrical breakdown. In this geometry electrical field is kept below 4 kV/mm at 50 kV operating voltage. The design parameters of the electron gun are presented in Table-1. The electron gun consists of an 8 mm of spherical oxide cathode (M-type dispenser), a grid and an anode. The cathode and grid electrode is mounted on 8" diameter conflat flange (NW150) and anode is separated by a 145 mm of inner diameter and 200 mm long ceramic tube which is at the other side of the cathode and grid assembly.

Table 1. Design parameters of the Electron Gun

Description	Parameters
Cathode Material	Pressed Ba-Ni
Cathode Diameter	8.0 mm
Operating Temperature	950.0 °C
Emission Current Density	3.0 A/cm ²
Beam Voltage	50.0 kV
Beam Current	1.5 A
Grid Voltage	0.2-1.5 kV
Beam Diameter	2.0 mm
Beam Emittance	3.5 π mm-mrad

The surface of ceramic insulator is corrugated to reduce the leakage current and electron gun is having zero insertions length into the vacuum chamber. The electron gun insulation is tested up to 80 kV DC between cathode and anode, 6 kV DC between cathode and grid (while the working design voltage is 50 kV DC only). The variation of electron gun current with grid voltage is shown in figure2. The holes are provided on the periphery of anode flange for pumping the gas molecules. The total conductance of the hole is greater than 100 litre/sec.

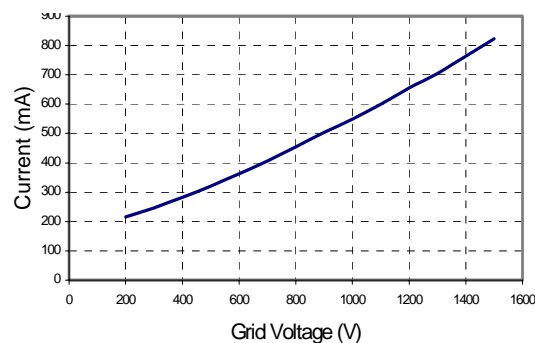

Figure 2. The variation of electron gun current with grid voltage

5. Activation of electron gun cathode

The activation of the electron gun cathode was carried out after achieving good vacuum. The cathode is pressed Barium-Nickel carbonates mixture. During activation these carbonates mixtures are converted into oxides and leads to contamination of walls of vacuum chamber and electron gun parts. This affects the quality of vacuum. To avoid this, the activation of electron gun cathode and vacuum process were carried out simultaneously by increasing of cathode power slowly. The activation processed is completed when vacuum is achieved less than 5×10^{-8} mbar. This in it-self gives the confirmation that the activation of gun cathode is satisfactory.

6. Electron beam collector, the faraday cup

In general for low beam power, faraday cup device is used for measuring beam current. The electron gun with 50 kV, 1.5 A (75 kW beam power), it is required to design and develop electron beam collector which can dissipate the power uniformly. The preliminary design study of electron beam collector has been carried out using EGUN software. The thermal analysis was also carried out using ANSYS software [5]. From the UHV point of view, the electron beam power distribution has been studied so that the vacuum out gassing and pressure distribution is kept under control. A high pressure will lead to gas-discharge due to the beam field and arcing might occur due to space charge field.

7. Personal safety

The following safety measures are incorporated for human beings as well as for equipments.

7.1 High voltage safety

The safety from possible hazards due to high voltage shock has been given highest priority. The complete system would be operated remotely and will be controlled via personal computer. The emphasis on grounding has been given to avoid any damage to instruments.

7.2 X-ray safety

When high power electron beam strikes to the target there is a chance of X-ray hazards. The proper X-ray monitoring and shielding will be provided where high power electron gun is under test.

8. Conclusion

The UHV setup along with electron gun was tested for its compatibility and achieved $< 2 \times 10^{-9}$ mbar pressure. The electron gun cathode was activated for recommended power ratings. In this, the degassing of the cathode was done and insulation testing was carried out between anode and cathode up to 80 kV DC and 6 kV DC between cathode and grid. The insulation was found satisfactory to operate electron gun to its design value. The further testing of the electron gun is under progress.

9. Acknowledgement

The authors wish to thank Mr. Deepak Mishra for his valuable contribution about electron gun. The authors are also thankful to Mr. R. J. Parmar for systems drawings. The staff members of accelerators workshop and chemical section are acknowledged for the work of fabrication, chemical cleaning and electro polishing of components.

10. References

- [1] Jain S K, Jain A, Hannurkar P R and Kotaiah S 2007 *Rev. of Sci. Instrum.* **78** 053301
- [2] Herrmansfeldt W B, 1988 EGUN-An Electron Optics an GUN Design Program **SLAC-33**
- [3] Prasad M, Pande S A and Hannurkar P R 2003 *Proceedings of InPAC* 301-302
- [4] Prasad M, Pande S A and Hannurkar P R 2005 *Proceedings of InPAC* 420-421
- [5] Kumar Ramesh, Mishra Deepak, Prasad M and Hannurkar P R 2006 *Proceedings of InPAC* 351-352