

## RF CONTROLS TOWARDS FEMTOSECOND AND ATTOSECOND PRECISION

F. Ludwig<sup>†</sup>, J. Branlard, L. Butkowski, M.K. Czwalianna, M. Hierholzer, M. Hoffmann,  
M. Killenberg, T. Lamb, J. Marjanovic, U. Mavric, J.M. Mueller, S. Pfeiffer, H. Schlarb,  
Ch. Schmidt, L. Springer, DESY, Hamburg, Germany  
M. Kuntzsch, K. Zenker, HZDR, Dresden, Germany

### Abstract

In the past two decades, radio-frequency (RF) controls have improved by two orders in magnitude achieving meanwhile sub-10 fs phase stabilities and 0.01% amplitude precision. Advances are through improved field detection methods and extensive usage of digital signal processing on very powerful field programmable gate arrays (FPGAs). The question rises, what can be achieved in the next 10 years? In this paper, a review is given of existing systems and strategies, current stability limitations of RF control systems and new technologies with the potential to achieve attosecond resolutions.

### RF CONTROLS WITH FS-PRECISION

Pump-and-probe experiments at Free-Electron-Lasers with 10 fs resolution require ultra-short electron beams with excellent longitudinal phase space and time jitter stability. This requires multiple bunch compressor stages, short- and long-term stable RF field in the accelerating modules and a precise reference distribution system.

#### RF-Controls Noise Contributions

In this section, the main noise contributions caused by the RF-control and their impact on the additional timing jitter are derived. Operating the accelerating structures at frequency  $f_{rf}$ , the arrival time jitter after a bunch compressor is given by [1]

$$\sigma_{t,out}^2 \approx \left(\frac{R_{56} \sigma_A}{c_0 A}\right)^2 + \left(\frac{C-1}{C}\right)^2 \left(\frac{\sigma_\phi}{2\pi f_{rf}}\right)^2 + \left(\frac{1}{C}\right)^2 \sigma_{t,in}^2 \quad (1)$$

with  $\sigma_{t,in}$  and  $\sigma_{t,out}$  the incoming and outgoing arrival time jitter,  $\sigma_A$  and  $\sigma_\phi$  the RF amplitude and phase stability,  $C$  the compression factor and  $R_{56}$  the momentum compaction factor of the chicane. To achieve a timing jitter in the order of 10 fs the relative RF amplitude stability and phase stability of the RF-control system with respect to the reference must be typically in the order of 0.01 %, respectively 0.01 deg at 1.3GHz cavity frequency. Neglecting cavity effects like micro-phonics, Lorentz-force detuning and beam-loading, the cavity regulation system can be solved algebraically within a small signal analysis in the Laplace-domain [2] or numerically for amplitude and phase. Assuming only white noise contributions from the field detection  $S_{\phi,0,DWC}$  and actuator chain  $S_{\phi,0,ACT}$ , proportional gain  $g_0$  and cavity bandwidth  $f_{12}$ , the minimum integrated jitter within the effective noise bandwidth  $g_0 f_{12}$  with (9,10) from [2] leads to

$$\sigma_\phi^2 \approx \left(g_0 S_{\phi,0,DWC} + \frac{1}{g_0} S_{\phi,0,ACT}\right) \frac{\pi}{2} f_{12} \quad \text{with} \quad (2)$$

$$g_{opt} = \sqrt{\frac{S_{\phi,0,ACT}}{S_{\phi,0,DWC}}}, \quad g_{max} = \frac{1}{4 t_D f_{12}}. \quad (3)$$

According to (2) cavities with smaller bandwidth produce less jitter. The loop latency is limited by cable propagation of 5.5 ns/m and FPGA processing delays to about  $t_D=1$  us, which limits for high bandwidth cavities of 100 kHz the gain to 1...5, requiring an actuator chain jitter in the order of 10 fs...20 fs. Low bandwidth cavities in the order of 100 Hz benefit from gains of more than 100 to suppress actuator noise. The demands on the field detection are less than 10 fs within the pulse repetition rate and effective noise bandwidth, typically [10 Hz, 100 kHz].

#### Field Detectors

The requirements on the field detectors in the GHz-range for superconductive cavities with less than 10 fs resolution for amplitude and phase are demanding.

- Amplitude and phase detection with 360deg
- Short-term stability <0.01%,<0.01° [10Hz,10MHz]
- Long-term stability <0.01%,<0.01° [forever,10Hz]
- Nonlinearity < -60dBc, <1% error
- Channel crosstalk < -80dB...-100dB
- Overall latency <100ns
- No AM to PM, no PM to AM conversion

Even though the LLRF community profits from the telecommunication industry, it was clear at that time, that such kind of detectors did not exist. This leads to the main features: 360 deg detection, short-term stability, channel-to-channel crosstalk, latency and no PM to AM conversion. Today widely used is the non-IQ sampling, which combines the advantages of existing technologies with phase noise power densities varying between 150 and 160 dBc/Hz provide sub-10fs resolution in various form-factors. The performance and spectral purity can be verified by splitting a reference into the detector providing zero differential phase noise. Since the amplitude detection is absolute the reference must have sufficient low amplitude noise. Such fingerprint is shown in Fig. 1 for a commercial detector in MicroTCA.4 crate form factor. The down-converter (DRTM-DWC10) operates at 1.3 GHz, with an intermediate frequency of 54.167 MHz, which is non-IQ sampled in a 16-bit digitizer (SIS8300L2V2) with a sampling rate of 81.25 MHz. Its spurious free raw data wideband and narrow band spec-

trum show the high quality of the system’s signal-integrity in the range of sub-10fs. The resolution can vary depending on the packaging and electromagnetic compatibility (EMC). The cumulative jitter for 0 dBm input power results in an amplitude stability of 0.004 %, respectively 0.002 deg (4.2 fs) within a 200 kHz bandwidth. With -115 dBFS white noise floor the ADC performance is nearly reached.

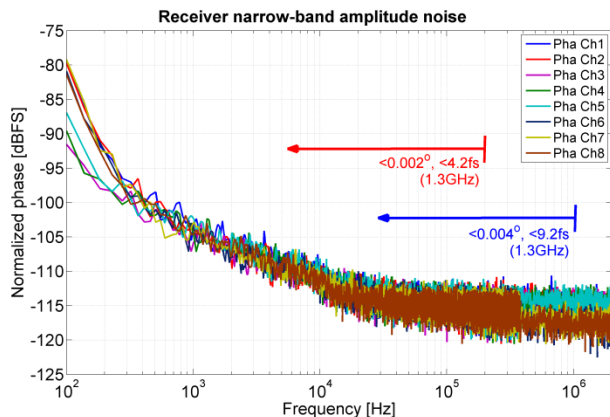

Figure 1: Field detector narrow-band phase noise with 0.002 deg, 4.2 fs (100 Hz - 200 kHz), respectively 0.004 deg, 9.2 fs(100Hz - 1 MHz) @ 1.3 GHz.

The LO-generation has an additive jitter of 2.6 fs within [10 Hz, 10 MHz]. The channel scaling behaviour shows for 8 channels the expected reduction in amplitude noise by a factor of  $\sqrt{8}$ . Due to the correlated noise from common LO-signal and ADC clock distribution the phase noise stability reduced only by factor of 1.5. Due to the phase conservation of front-end mixers the input jitter is ‘magnified’ depending on the frequency ratio  $f_{RF}/f_{IF}$ , which relaxes the clock jitter requirements for ADCs to about 100 fs.

Direct sampling for field detection is wideband and flexible. The cavity signal is sampled directly, front-end receivers are not needed. Over the last decade modern interleaved ADC architectures with sample rates of 4Gsp/s (e.g. Xilinx, UltraScale RFSoc) combined with powerful FPGAs approach the amplitude stability of non-IQ detectors. Spur calibration is offered on-chip. But due to the high input frequency the sampling clock and ADC aperture jitter still degrades the phase noise performance.

### LLRF Systems

As an example for superconductive RF (SRF) operation, the EuXFEL accelerator at DESY based on superconductive cavities at 1.3GHz uses several cavities in a vector-sum per klystron [3]. In total 27 RF stations, 800 cavities and over 3000 RF signals are processed. Figure 2 shows the schematic of a LLRF station, which houses MicroTCA.4 multi-channel-down-converters (uDWC), digitizers (uADC) for vector-sum pre-processing, a main FPGA controller (uTC) and an up-converter (uVM) driving the pre-amplifier with klystron. The LO-Generation housed in a 19” module or extended rear transition mod-

ule (eRTM) on a managed RF-backplane within a MicroTCA.4 19” crate. To achieve the long-term stability a drift calibration module (DCM) injects the reference into the LLRF-station. The short-term stability is achieved per channel to 0.004 %, respectively 0.002 deg, as described before. The overall measured rms arrival time jitter before the SASE stations for 600 pulses is 12.9 fs [4].

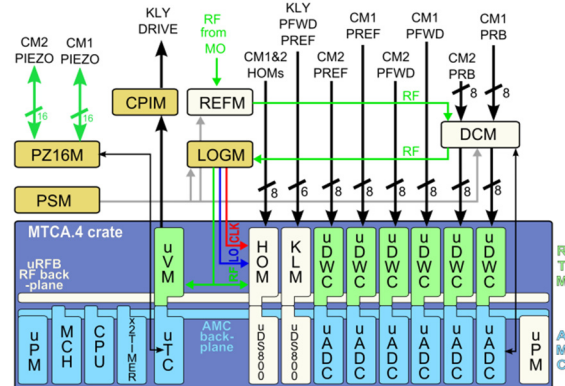

Figure 2: Schematic of a LLRF system of the Eu-XFEL.

For example, normal-conductive RF (NRF) operation, e.g. at the SINBAD or REGAE facility at DESY, use high bandwidth structures above 60 kHz for acceleration and RF-pulses below 10 us duration. The low-noise high-power chain adds with the up-converter 2.9 fs, pre-amplifier 3.4 fs and klystron with modulator 13.9 fs in total 14.5 fs, respectively 0.049 % amplitude stability with a floor of -165 dBc/Hz within the range of minutes to 1 MHz bandwidth. With a total latency of about 700 ns a 10 fs arrival time is expected with a maximum gain of about 3. A Smith predictor feedback algorithm helps to overcome the gain limitation drawbacks as a consequence of the fundamental latency issue. To gain an improvement of a factor of 10 which would allow for 1 fs rms field stability in phase, the high power amplifier chain requires significant improvements in their 1/f-noise e.g. by choosing superior technologies and removal of all spur lines.

Contrarily, CW-operated SRF cavity e.g. at the ELBE accelerator facility at HZDR, is shown in Fig. 3.

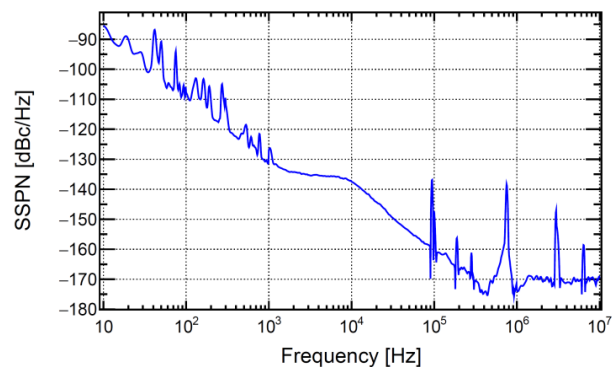

Figure 3: Cavity phase noise spectrum at ELBE.

Content from this work may be used under the terms of the CC BY 3.0 licence (© 2019). Any distribution of this work must maintain attribution to the author(s), title of the work, publisher, and DOI

The probe phase noise spectrum is here measured directly with a commercial phase noise analyser in correlation. The cavity roll-off at the effective bandwidth of about 15 kHz, pass band modes and the reference 1/f-noise is clearly visible.

### LLRF Digital-Processing

In the last decade low-latency powerful FPGAs have been widely used in the LLRF community. In combination with CPUs numerous control algorithms can be realized to reduce repetitive disturbances

- Iterative learning control
- Fundamental mode filters
- Beam loading compensation
- Set-point optimization
- Loop gain/phase correction

and stochastically disturbances

- MIMO controller
- Gain scheduling
- Drift compensation
- Intra-train beam based feedbacks

of the LLRF system. Resonance control for slow and fast piezo tuners can be realized. Especially for pulsed driven and vector-sum machines a flat RF-field during beam injection can be achieved. To qualify the performance of the regulation, the in-loop signal, as depicted in Fig. 4 is shown for the FLASH facility.

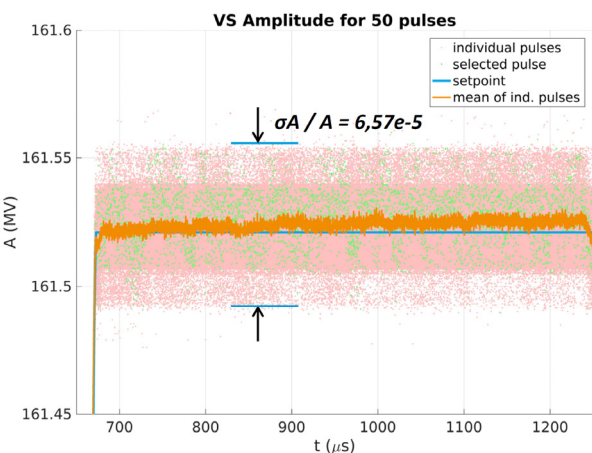

Figure 4: Amplitude in-loop performance at FLASH.

The pulse-to-pulse stability is far below the specification of 0.01 % for amplitude and 0.01 deg for phase. For large feedback gains the field detector noise is imprinted onto the beam within the effective noise bandwidth of the loop. An out-of-loop verification using bunch arrival time monitors showed a stability of less than 25 fs. This puts an upper limit on the actual achieved phase jitter in the SRF cavities of 12 mdeg rms. Unfortunately, other error sources influencing the bunch arrival time jitter exist, which cannot be easily separated.

### Long-term Stability

A long-term stable machine is essential for reproducible machine restarts, fast operation-mode changes and low maintenance time. Long-term disturbances from various sub-components like amplifiers, cables, mixers, splitter etc. are in the order of picoseconds with conversion constants of  $\sim 0.1$  %/K,  $\sim 0.1$  deg/K. The long-term stability depends on temperature and strongly on humidity. Several methods were developed to achieve long-term stable field detection on the 10 fs level.

- Passive stabilization
- Reference tracking
- Reference injection
- 2-tone calibration
- Reflection at the cavity

The passive stabilization requires a temperature rack stabilization of about 0.1 K<sub>pp</sub> and a proper sealing of all RF-circuits. Reference tracking for fully symmetric receivers can suppress correlated errors from the LO and clock generation, but highly symmetric cable guidance is required and in practice difficult to fulfil. Reference injection injects the reference into the detectors before fill-time of the RF-pulse to compensate for its amplitude and phase errors [5]. During cavity field measurement the correction is applied. The Drift-Compensation-Module (DCM) at the Eu-XFEL reduces long-term drifts by a factor of more than 150 to 40 fs peak-to-peak [5]. Figure 5 shows the applied phase correction and the humidity variations. A sensitivity of humidity changes of about 0.1 deg/%RH has been determined for the entire setup.

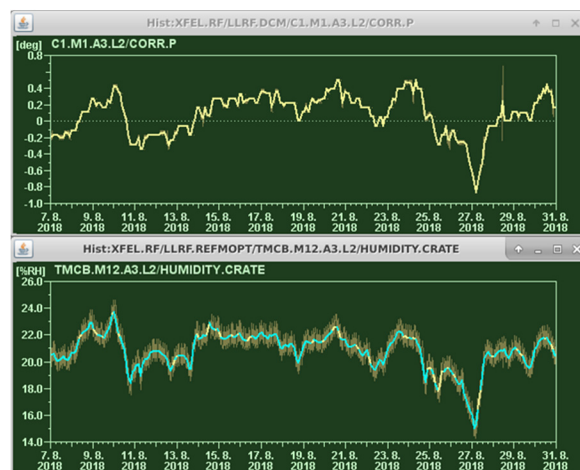

Figure 5: EuXFEL phase corrections of a LLRF station (top) and humidity changes (bottom) over a period of 3 weeks.

### Packaging and EMC

The precision of LLRF systems with fs-resolution depends strongly on its packaging. In the past 10 years the community presented various form-factors, like conventional RF-packaging, piggy-back solutions, standards and proprietary system with different success.



Content from this work may be used under the terms of the CC BY 3.0 licence (© 2019). Any distribution of this work must maintain attribution to the author(s), title of the work, publisher, and DOI

To achieve destructive interference ultra-low noise tuneable amplitude and phase actuators, an automated carrier suppression tracking and RF-sources with low amplitude noise are required. Compared to double balanced RF-mixers based on Schottky diodes in forward direction, promising devices are varactor diodes and RF-MEM switches for by-step phase-shifters, which showed so far no additional jitter. Due to the tracking of the destructive interference of the carrier, this method can be much easier applied to CW-machines or very slow RF-transients with non-IQ detectors in a hybrid configuration. This frequency range can also be covered by 2-tone calibration or beam based feedback systems.

Using the carrier suppression method for amplitude and phase noise instruments is less complicated due to the fact that symmetric 1/f-noise from two branches in correlation vanishes.

### Receiver Concepts

For as-resolution, receiver concepts have to be revised. To benefit from the available high RF-power signals of the cavity, it is shown that hybrids of IQ-demodulation and non-IQ sampling in combination with ADC parallelization are good candidates to achieve uncorrelated resolutions in the order of 1...3 fs within 1MHz bandwidth [13]. Far-off the carrier, a noisy LO-generation is not needed, but an IQ-calibration to avoid AM to PM effects. Depending on the grade of ADC parallelization a floor of -160 dBc/Hz...-170 dBc/Hz seems feasible. For single cavity regulation an analog and digital hybrid system would combine advantages of both worlds, as depicted in Fig. 8. LLRF systems with slow RF-transients can combine non-IQ detectors with carrier suppression or analog detection in a hybrid configuration. LLRF systems with fast RF-transients require a broadband hybrid for field detection. Hybrids with small signal detectors will be a challenge.

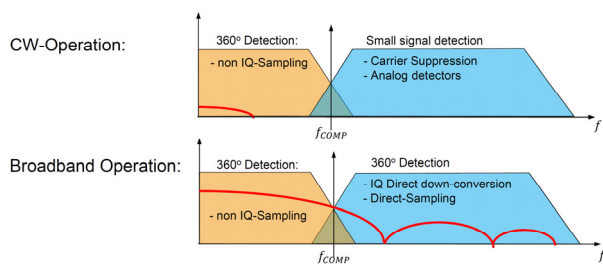

Figure 8: Down conversion hybrid options.

### CONCLUSION

RF-Controls with sub-10 fs phase and 0.01% amplitude precision is nowadays available for the accelerator community in modern standards like MicroTCA.4 and proprietary systems. Advances are through improved field detection, EMC compliant packaging and extensive usage of digital signal procession on very powerful FPGAs. A major limitation for improvements is still the limited

noise spectral density of ADCs in digital systems, which forces the community to complicated hybrid solutions. A massive on-chip ADC parallelization would solve this problem.

RF-Controls with sub-100as resolution for SRF systems seem feasible for high- $Q_L$  cavity operation, improved high power chains, hybrid field detectors based on carrier suppression or brute force channel parallelization. NRF systems benefit from low latency hybrids, high-power chain stabilization loops and a further reduction of noise in high power amplifiers.

### REFERENCES

- [1] H. Schlarb *et al.*, “Next Generation Synchronization System for the VUV-FEL at DESY”, in *Proc. FEL’05*, Stanford, CA, USA, Aug. 2005, paper MOPP036, pp. 118-121.
- [2] F. Ludwig *et al.*, “Phase Stability of the Next Generation RF Field Control for VUV- and X-ray Free Electron Laser”, in *Proc. EPAC’06*, Edinburgh, UK, Jun. 2006, paper TUPCH188, pp. 1453-1455.
- [3] J. Branlard *et al.*, “The European XFEL LLRF System”, in *Proc. IPAC’12*, New Orleans, LA, USA, May 2012, paper MOOAC01, pp. 55-57.
- [4] H. Schlarb *et al.*, “Precision Synchronization for large scale Accelerators”, CLEO2019, San Jose, USA.
- [5] F. Ludwig *et al.*, “Drift calibration for the European XFEL”, LLRF Workshop 2017, Barcelona, Spain.
- [6] Elya B. Joffe, Kai-Sang Lock, “Grounds for Grounding”, ISBN: 978-0-471-66008-8, 01/2010, Wiley-IEEE Press.
- [7] F. Ludwig *et al.*, “High Performance Measurement Applications in MicroTCA.4”, 5<sup>th</sup> MicroTCA Workshop 2016, Hamburg, Germany.
- [8] R. Rybaniec *et al.*, “FPGA-Based RF and Piezo controllers for SRF Cavities in CW Mode”, *IEEE Transactions on Nuclear Science*, vol. 64, no. 6, June 2017.
- [9] J. Branlard *et al.*, “RF Control Challenges and Results for a CW Operation of the European XFEL”, Matter & Technology Meeting 2019, Jena, Germany.
- [10] Klaus H. Sann, “The Measurement of Near-Carrier Noise in Microwave Amplifiers”, *IEEE Transactions on Microwave Theory and Techniques*, vol. mtt-16, no. 9, September 1968.
- [11] E. Rubiola *et al.*, “Advanced Interferometric Phase and Amplitude Noise Measurement,” *Rev. Sci. Instrum.*, vol. 73 no.6 pp 2445-2457, 2002.
- [12] T. Berenc *et al.*, “An Interferometric Residual Phase Noise Measurement System at S-Band”, LLRF Workshop 2013, Lake Tahoe, California, USA.
- [13] Rohde & Schwarz GmbH & Co. KG Munich, Germany, [https://www.rohde-schwarz.com/de/applikationen/1-mhz-bis-50-ghz-phasenrauschmessplatz-mit-direkter-abwaertsmischung-und-kreuzkorrelation-application-card\\_56279-231872.html](https://www.rohde-schwarz.com/de/applikationen/1-mhz-bis-50-ghz-phasenrauschmessplatz-mit-direkter-abwaertsmischung-und-kreuzkorrelation-application-card_56279-231872.html)