

# CRYOGENIC CURRENT COMPARATOR (CCC): ABSOLUTE BEAM CURRENT MEASUREMENT IN THE ORDER OF nA\*

L. Crescimbeni<sup>†</sup>, D. M. Haider, A. Reiter, M. Schwickert, T. Sieber  
GSI Helmholtz Centre for Heavy Ion Research, Darmstadt, Germany

M. Schmelz, R. Stolz<sup>3</sup>, V. Zakosarenko<sup>4</sup>, Leibniz IPHT, Jena, Germany

F. Schmidl, Friedrich-Schiller-University Jena, Jena, Germany

T. Stoehlker<sup>1,2</sup>, V. Tympel, Helmholtz Institute Jena, Jena, Germany

<sup>1</sup>also at GSI Helmholtz Centre for Heavy Ion Research, Darmstadt, Germany

<sup>2</sup>also at Institute for Optics and Quantum Electronics, Jena, Germany

<sup>3</sup>also at Technical University Ilmenau, Ilmenau, Germany

<sup>4</sup>also at Supracon AG, Jena, Germany

## Abstract

The Cryogenic Current Comparator (CCC) is able to provide a calibrated non-destructive measurement of beam currents with a resolution of 10 nA or better. The non-intrusive, absolute intensity measurement of weak ion beams ( $< 1 \mu\text{A}$ ) is essential in heavy ion storage rings and in transfer lines, as the ones in FAIR. With standard diagnostics, this measurement is challenging for bunched beams and virtually impossible for coasting beams. The CCC provides reliable values for beam currents of this order of magnitude or lower, independent of ion species and without tedious calibration procedure.

The test in the heavy-ion storage ring CRYRING@ESR at GSI has confirmed its viability, and has also suggested several improvements to the detector hardware. Therefore, an upgrade of the CCC system was performed and tested in laboratory environment. A review of these improvements will be presented herein, with a detailed discussion of the most important measures and the next development steps for the final version of the CCC for FAIR.

## INTRODUCTION

The non-destructive and absolute monitoring of ion beams with an intensity in the order of nA is an essential requirement in accelerator facilities that produce slowly extracted ion beams for nuclear physics research or low intensity beams of rare isotopes and antiprotons. Both is the case at the planned FAIR facility at GSI. In general, for coasting beams standard diagnostic systems are not able to provide measurements in the range of nA without major efforts. Even then, the instruments that can provide some information in this range have problems to deliver the high precision that is required (e.g. Schottky [1]), and are destructive, at least partially, reducing severely the possibility of using them as monitoring devices in storage rings (e.g. Secondary Electron Monitors) or are limited to bunched beams (BPM, Integrating Current Transformer).

\*Work supported by AVA – Accelerators Validating Antimatter the EU H2020 Marie-Curie Action No. 721559 and by the BMBF under contract No 05P21SJR1.

<sup>†</sup>l.crescimbeni@gsi.de

<sup>¶</sup>Model PT415 from Cryomech Inc, Syracuse, NY, USA

The Cryogenic Current Comparator (CCC) uses a dc Superconducting Quantum Interference Device (SQUID) as an extremely sensitive magnetometer for the beam azimuthal magnetic field to provide the requested high-precision measurement of low-intensity currents while being non-destructive and easy to calibrate. Five CCCs are planned to be installed in the FAIR facility. In preparation, a prototype was tested in the laboratory and installed in the heavy-ion storage ring CRYRING@ESR at GSI to be tested with beam. It is based on the FAIR-Nb-CCC-xD [2] that is part of the family of CCC-xD that has been developed for the use with the beamline dimensions at FAIR HEBT ( $\varnothing 150 \text{ mm}$ ). A similar CCC with smaller dimensions has been developed for the CERN Antiproton Decelerator and is a key instrument for optimization of the deceleration scheme [3].

## STATE OF THE ART AT GSI

The CCC has been tested in CRYRING@ESR with different ion species under various beam conditions (e.g. coasting and bunched beams) as well as different beam intensities. The tests confirmed the viability of the detector and its current resolution in the order of nA (Fig. 1) under all operating conditions. The performance of the system previously observed in the laboratory could be reproduced to large extent in the beamline.

The test in CRYRING@ESR has also shown some limitations of the prototype. The first is a cryogenic limitation: the CCC is allocated in a beam line cryostat (developed with ILK company Dresden [4]), which provides stable operating conditions (pressure and temperature) to the CCC. The system is equipped with a local helium liquefier [5]. This solution should be able to provide an unlimited operation time without the need of refill. However, in CRYRING the operating time was limited to 7 days due to an excessive Helium evaporation, higher than the one that can be managed by the liquefier, so the helium gas is forced to leave the system.

The other two main limitations are instead correlated to the CCC itself. They are caused by a limited slew rate and an insufficient magnetic shielding factor. The limited slew rate of the detector ( $0.16 \mu\text{A}/\mu\text{s}$  (with  $f \leq 200 \text{ kHz}$ ) [2]) can in case of high intensities and fast rise/fall times of the

pulse lead to local artefacts or to baseline drift effects. It's possible to reduce the presence of artefacts and baseline drifts by adapting the pick-up circuit, but this will reduce the current resolution of the CCC due to the additional thermal noise of the filtering element.

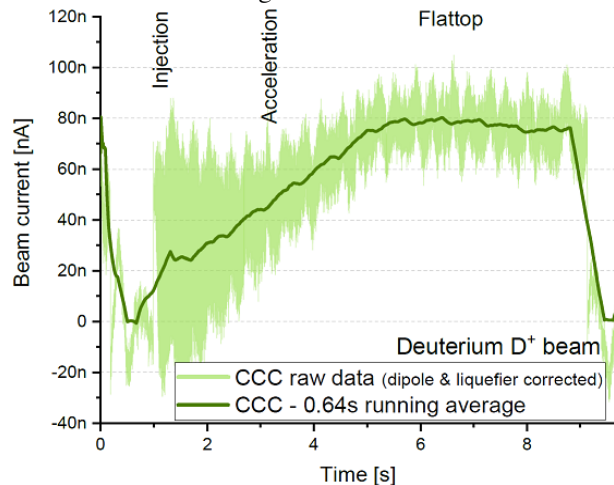

Figure 1: Beam current measurement of a low-intensity bunched beam of deuterium  $D^+$  (5 MeV/u at flattop), corrected for the dipole ramp and the liquefier noise (light green), measured with a bandwidth of about 200 kHz [2] and smoothed with a running average (dark green).

The actual FAIR-Nb-CCC-xD has a radial superconducting shield. Simulations estimate the magnetic screening factor at around 70 dB [6]. Using the Helmholtz coils we were able to study the effect of magnetic perturbation on the CCC, measuring the real value of the shielding factor in the laboratory. Comparing the well-known field produced by the Helmholtz coils with the SQUID signal it was possible to confirm the value of 70 dB for the screening factor.

Due to this rather low value of the screening factor the CCC is sensible to external magnetic field (like the dipole ramps). It's possible to use software filters to remove these signals from the data during offline analysis if the magnetic field is stable and well known, as in the case of the dipole ramps, but this is often not the case.

To solve these issues a new axial CCC is under development, that will have a better shielding factor and a higher slew rate, as show in the following.

## CRYOGENICS INVESTIGATIONS

The investigation of the primary source of excessive helium evaporation lead to implementation of some new equipment to the existing system. As an example, an active pressure control system was added, managing the amount of helium gas that leaves the system. This step improved the pressure stability reducing at the same time the baseline drift in the signal, which derived from pressure oscillations in the vessel.

These changes to the cryostat (schematic in Fig.2) have reduced the amount of gas leaving the vessel to almost a third (from 7 l/day to 5 l/day), increasing the standing time to 10 days.

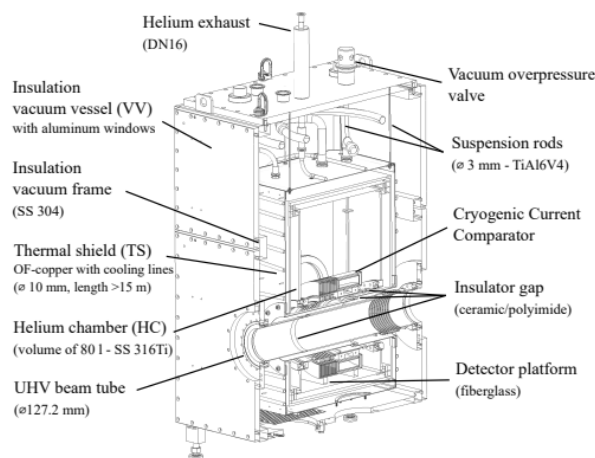

Figure 2: Schematic of CCC beam line cryostat, with its main components highlighted.

Furthermore, a new thermal shield is currently under development, with an enthalpy cooling return line of reduced length but increased diameter to reduce the pressure drop on the line through the liquefier and increase the thermal coupling of the line with the shield itself. This will increase the efficiency of the liquefier and further decrease the heat load on the helium vessel.

The new thermal shield is also important to reduce the magnitude of the 1.4 Hz periodic perturbation due to the liquefier's compressor. The analysis of this perturbation has shown that its intensity is directly linked to the length of the return line and vanishes completely if the return line is bypassed. This is obviously not realistic for the detector, because the return line is essential to keep the thermal shield at low temperature ( $\sim 100$  K) to reduce the heat load on the vessel. However, the new solution of a shorter return line will achieve both advantages: it will provide a better thermal coupling of the cold helium gas to the shield and also reduce the intensity of the 1.4 Hz periodic perturbation, improving the performance of the detector.

An ultimate solution to this issue will be the installation of a new liquefier, that will provide an additional 10 l/day of liquefaction, allowing us to reach the expected unlimited standing time.

## NEW AXIAL CORELESS CCC

A new type of CCC, developed together with Leibniz IPHT, will be made of lead with an axial shield geometry and without a high permeability core (Fig.3).

It is expected to be less sensitive to external perturbations, in particular very low-frequency noise ( $< 1$  Hz), caused by magnetic field caught inside the core material [7] (for CCC version with core). It is also expected to be less sensitive to mechanical disturbances, both properties will allow an increase of the current resolution of the detector itself.

The new coreless lead CCC will have a much higher screening factor thanks to the axial magnetic shield composed of 10 layers of lead sheet [7]. The simulation shows a screening factor higher than 200 dB, reducing the effect

of the magnetic perturbation in the order of  $100 \mu\text{T}$  (amplitude similar to the dipole ramp perturbation observed with the CCC at CRYRING@ESR) to a level much lower than the sensitivity of the detector.

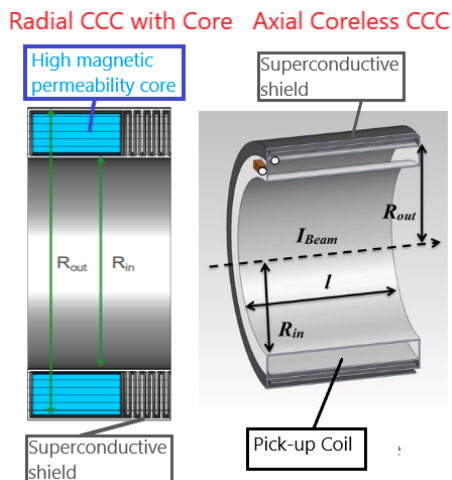

Figure 3: Left: FAIR-Nb-CCC-xD, radial geometry, with high permeability core. Right: Axial geometry coreless CCC, made of lead, the core is missing and the pickup coil is filled only with nonmagnetic foam for structural support.

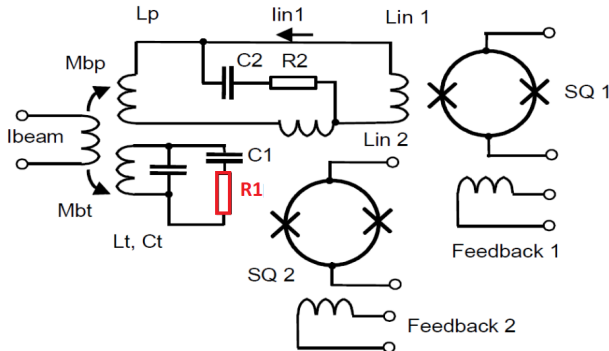
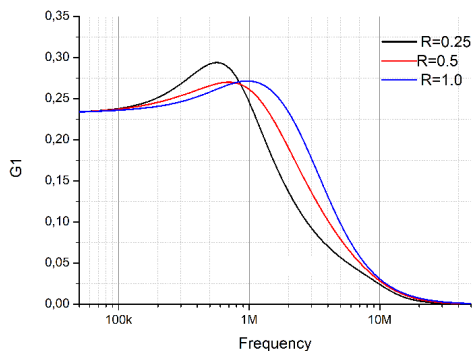

Figure 4: Simulations of the transfer function for CN4 SQUID and schematic of the two parallel detecting SQUID system. Upper: CN4 SQUID transfer function. Lower: Circuit schematic with two SQUIDS of staggered sensitivity and their feedback system; the damping circuit has been added to avoid resonance peaks in the frequency of interest. The chosen value for the resistance is 0.5 Ohm, to provide the smoothest gain without decreasing the bandwidth

The improved screening factor, together with its lower sensitivity to lower-frequency perturbation, will strongly improve the current resolution of the detector in the accelerator environment. This new CCC will in parallel be equipped with a two parallel SQUID system (Fig.4), a sensitive SQUID and thus with a lower slew rate (type CN4) and a SQUID with a 25 times lower sensitivity and hence higher slew rate (type CN2). Both SQUIDS are on one chip and were provided by Leibniz IPHT and supracon AG.

The parallel use of the two SQUIDS refers to the introduced cascade principle [8]. The two parallel SQUID system, thanks to the higher slew rate of the lower sensitive SQUID, will allow to track also the fast changing signals without introducing additional filtering elements and hence without decreasing the resolution due to the additional thermal noise, as it was done for the FAIR-Nb-CCC-xD in CRYRING.

## CONCLUSIONS

The cryogenic work performed in the laboratory has allowed to strongly reduce the heat input on the helium vessel and with the development of the new thermal shield and the installation of the new liquefier it will be possible to overcome the observed cryogenic issues of the CCC for FAIR.

The axial CCC will have a much higher magnetic screening factor, 200 dB in comparison to 70 dB of the FAIR-Nb-CCC-xD, which will eliminate the effect of external magnetic field on CCC signal. It will also have a reduced low frequency noise, which should improve the performance and the current resolution of the detector. The higher slew rate, achieved thanks to the two parallel SQUID systems, will allow for tracking fast changing signals with somewhat reduced resolution and the slow changing signals of the beam with ultimate resolution. Thereafter, the presence of artefacts or baseline drifts will be strongly reduced, without a decrease in resolution.

## NEXT STEPS

The new thermal shield is actually under construction and will be installed and tested in mid 2023.

Furthermore, the first version of the coreless lead CCC is at the time of this report under final laboratory test at FSU Jena. In a next step, it will be installed in the beamline cryostat in GSI. The new CCC will be tested in the laboratory at GSI, allowing us to complete an accurate comparison between the performances of the ‘classical’ niobium FAIR-CCC-XD and of the coreless axial version made from lead.

The coreless lead CCC will finally be tested in the accelerator environment before the end of the year. The beamline cryostat will be installed in one of the experimental caves at GSI to test it under the exact same conditions in which it will be used in FAIR. This test will be the final validation of the CCC prototype, allowing us to get essential information on the performances and to complete some final improvements to achieve the best possible version of the CCC detector for FAIR.

## REFERENCES

- [1] M.E. Angoletta *et al.*, “Schottky Based Intensity Measurements and Errors Due to Statistical Fluctuations”, in *Proc. 8th Int. Particle Accelerator Conf. (IPAC'17)*, Copenhagen, Denmark, pp. 385-388, Sep. 2017.  
doi: 10.18429/JACoW-IPAC2017-MOPAB112
- [2] P. Seidel *et al.*, “Cryogenic current comparators for larger beamlines”, *IEEE Trans. Appl. Supercond.*, vol. 28, no. 4, pp. 1601205, Jun. 2018.  
doi:10.1109/TASC.2018.2815647
- [3] M. Fernandes *et al.*, “Non-perturbative measurement of low-intensity charged particle beams”, *Supercond. Sci. Technol.*, vol. 30, pp. 015001, Nov 2016.  
doi: 10.1088/0953-2048/30/1/015001
- [4] D.M. Haider *et al.*, “Versatile beamline cryostat for the Cryogenic Current Comparator (CCC) for FAIR”, in *Proc. 8th Int. Beam Instrum. Conf. (IBIC'19)*, Malmö, Sweden, p. 78-81, Sep. 2019.  
doi:10.18429/JACoW-IBIC2019-MOPP007
- [5] D.M. Haider *et al.*, “Commissioning of the Cryogenic Current Comparator (CCC) at CRYRING”, in *Proc. 10th Int. Beam Instrum. Conf. (IBIC'21)*, Pohang, Rep. of Korea, p. 349-352, Sep. 2021.  
doi: 10.18429/JACoW-IBIC2021-WE0B02
- [6] H. De Gerssem, N. Marsic, *et al.* Finite-element simulation of the performance of a superconducting meander structure shielding for a cryogenic current comparator. *Nucl. Instrum. Methods Phys. Res. Sect. A*, vol. 840, pp. 77–86, December 2016.  
doi:10.1016/j.nima.2016.10.003
- [7] V. Zakosarenko *et al.*, “Coreless SQUID-based cryogenic current comparator for non-destructive intensity diagnostics of charged particle beams”, *Supercond. Sci. Technol.*, vol. 32, Dec. 2018, pp. 014002.  
doi: 10.1088/1361-6668/aaf206
- [8] T. Schönau, M. Schmelz, *et al.* SQUID-based setup for the absolute measurement of the Earth’s magnetic field. *Supercond. Sci. Technol.*, 26(3): 035013, January 2013.  
doi:10.1088/0953-2048/26/3/035013